

SIGN PUNCHING, STRINGER AND SUPPORT LOCATION DETAILS - ROUTE MARKER SIGNS

D-754-64

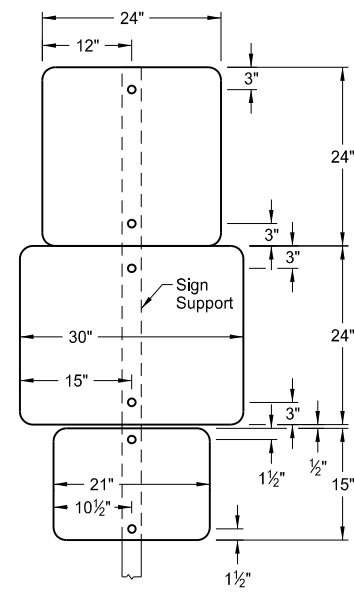

1 Post

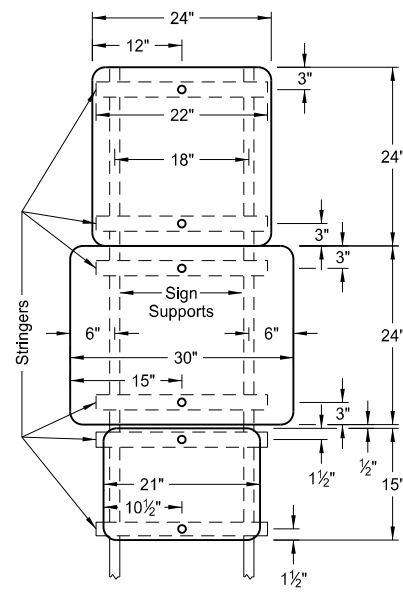

2 Posts

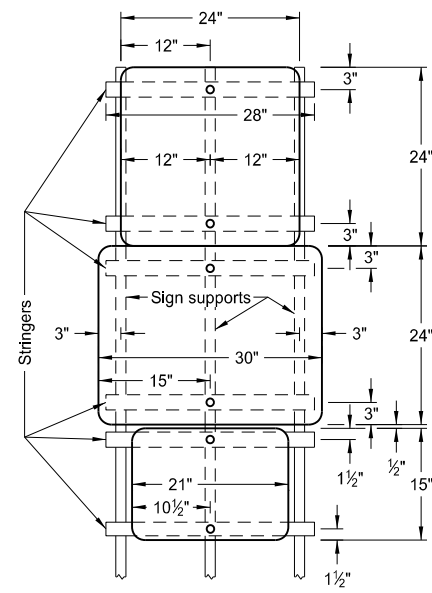

3 Posts

ASSEMBLY NO. 414

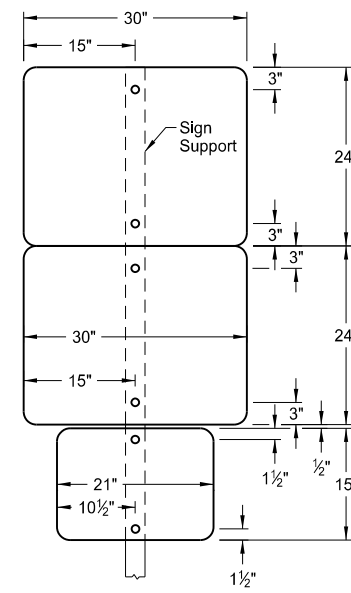

1 Post

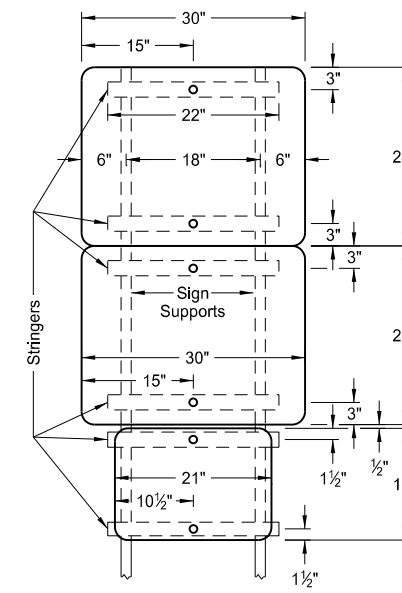

2 Posts

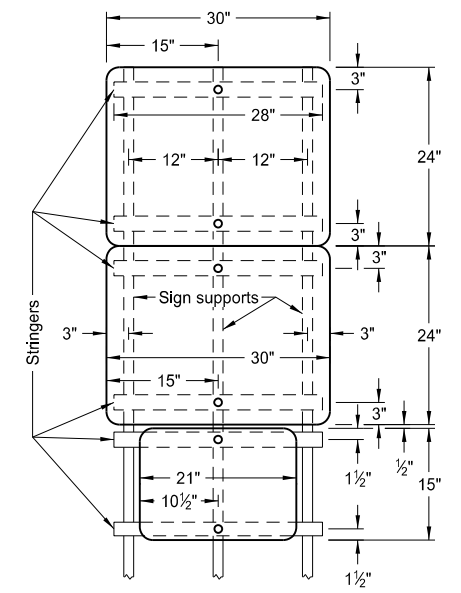

3 Posts

ASSEMBLY NO. 415

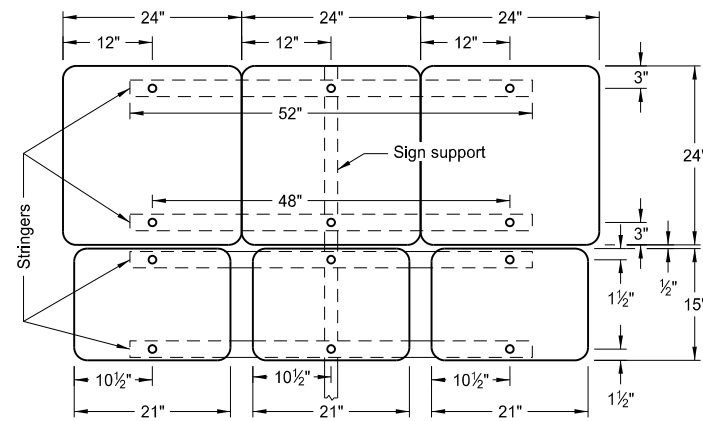

1 Post

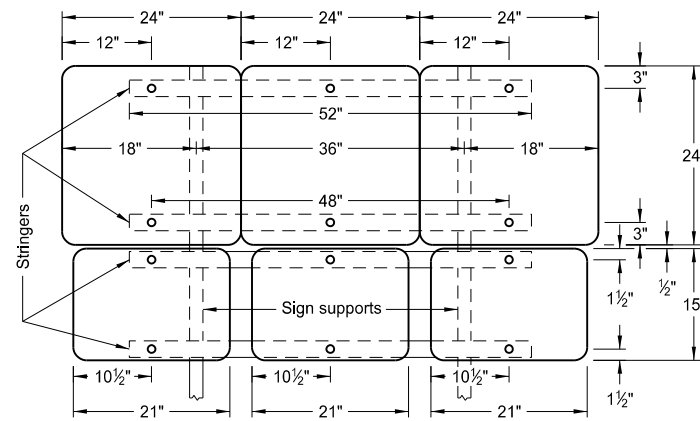

2 Posts

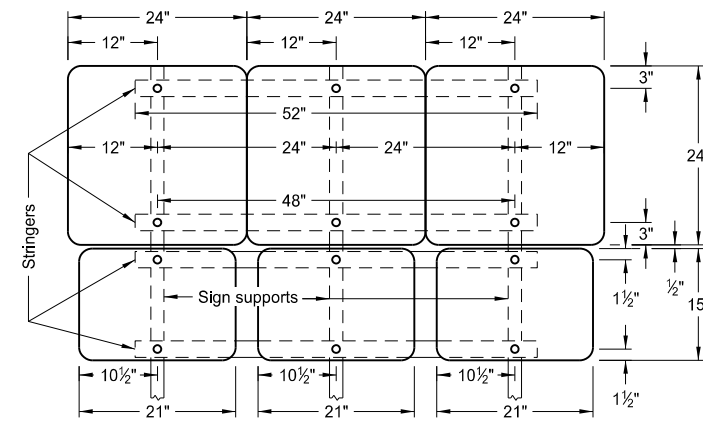

3 Posts

ASSEMBLY NO. 416

Notes:

1. Use 0.100 inch minimum thickness sign backing material.
2. Use 1 1/2"x1 1/2" perforated square tube stringer.
3. Punch holes round for 3/8" bolt.

NORTH DAKOTA DEPARTMENT OF TRANSPORTATION	
8-22-12	
REVISIONS	
DATE	CHANGE
8-30-18	Updated notes to active voice.
9-05-19	New Design Engineer PE Stamp

This document was originally issued and sealed by
Kirk J Hoff,
Registration Number
PE- 4683,
on 9/05/19 and the original document is stored at the North Dakota Department of Transportation