

RESEARCH REPORT DOCUMENT PAGE

1. Report No. ND 95-03		2. Report Date October 2001		3. Contract No. N/A		4. Project No. IM-6-029(022)186	
5. Title and Subtitle Dowel Bar Retrofit for Load Transfer				6. Report Type Work Plan <input type="checkbox"/> Construction <input type="checkbox"/> Evaluation <input type="checkbox"/> Final <input checked="" type="checkbox"/>		7. Project No. IM-8-029(003)022	
						8. Project No.	
						9. Project No.	
						10. Project No.	
11. Author(s)/Principle Investigator(s) Curtis Dunn, Bryon Fuchs							
12. Performing Organization Name and Address NDDOT M+R <input checked="" type="checkbox"/> NDDOT OTHER* <input type="checkbox"/> NDSU <input type="checkbox"/> UND <input type="checkbox"/> UGPTI <input type="checkbox"/> OTHER* <input type="checkbox"/> *see supplementary notes				13. Sponsoring Agency Name and Address North Dakota DOT Materials and Research Division 300 Airport Road Bismarck ND 58504-6005			
14. Supplementary Notes							
15. Abstract Purpose and Need Many jointed plain concrete pavements were constructed without dowels at transverse joints. Load transfer across such joints was primarily accomplished through aggregate interlock. However, as the existing pavements became older, the volume of heavy truck traffic increased. The load increase coupled with temperature variations caused the joints to open wider with time and reduce the effectiveness of aggregate interlock. Objective The objective of this study was to determine if dowel bar retrofitting would prevent faulting from recurring in jointed concrete pavement. Scope Test sections were evaluated for a period of six years on an annual basis. Items evaluated were: Monitoring of distresses around the dowel bars. Performance and comparison of the two concrete mixes used in the test sections, non-destructive deflection testing will be performed annually for load transfer across the doweled joints, and this testing was accomplished with the use of a falling weight deflect meter (FWD). The location of the test sections are on Interstate 29 in the southbound lane near reference point 188 which north of Drayton, ND and also near reference point 40 which is located south of the Christine interchange. Summary Project IM-6-029(022)186: Sections containing Patchroc 10-60 material Every joint in the 1,000' segment that was evaluated is experiencing at least one type of distress in their corresponding dowel bar slots. Distresses related to displaced core boards, durability of the mix (raveling and erosion), insufficient vibration (as determined by the cores taken by the Grand Forks District, refer to photo 1 on page 7), or excess sealant caulk is prevalent in the Patchroc 10-60 mix. FWD analysis shows approximately 42% load transfer in this segment, which is significantly lower than originally constructed. Performance of the test section containing the Patchroc 10-60 material is poor. The poor performance can be attributed to the mix material and poor construction. Sections containing 3U18 patch mix Approximately 62% of the joints in the 1,000' segment evaluated is experiencing at least one type of distress in their corresponding dowel bar slots. Some of the retrofit sections containing the Minnesota specified mix 3U18 are experiencing similar distresses as those related to the sections containing the Patchroc 10-60 mix. The retrofit sections containing the Minnesota specified mix 3U18 also experienced mix problems in the form of shrinkage cracks along the edge between the mix and the existing PCC. At this time, this section does not appear to show any signs of eroding or raveling of the mix, which may indicate greater performance from a standpoint of durability. FWD analysis shows approximately 43.4% load transfer in this segment, which is lower than originally constructed. Performance of this test section containing the Minnesota specified mix 3U18 patch mix is fair. The fair performance is attributed primarily to poor construction. Project IM-8-029(003)022: Every joint in the 1,000' segment evaluated is experiencing at least one type of distress in their corresponding dowel bar slots. Distresses related to core board failures, durability of the mix (raveling and erosion), or excess sealant caulk is prevalent in the Patchroc 10-60 mix. The average load transfer across the joints is approximately 95%. As opposed to the Grand Forks test sections the Fargo test section appears to be sustaining its ability to transfer traffic loads across the joints. Performance of this test section is good with one exception, durability. This test section appears to have had better construction as noted with the low number of construction related distresses and the load transfer is excellent. The problems associated with the raveling of the Patchroc 10-60 material appears to be in the mix itself and not related to construction. Recommendation It is recommended that dowel bar retrofit projects move forward as a way to restore load transfer in PCC pavements provided close scrutiny and adherence to the specifications are met during construction.							
16. Key Words Pavement Concrete Joints Dowels Load Transfer		17. Distribution Statement No restrictions. This document is available to the public from: North Dakota Department of Transportation Materials and Research Division: 300 Airport Road Bismarck ND 58504-6005 Office: (701) 328-6900				18. No. of Pages 72	
						19. File type/Size pdf/2.9 MB	

**NORTH DAKOTA
DEPARTMENT OF TRANSPORTATION**

MATERIALS AND RESEARCH DIVISION

Experimental Study ND 95-03

Dowel Bar Retrofit for Load Transfer

Final Report

Projects IM-6-029(022)186 & IM-8-029(003)022

October 2001

Prepared by

NORTH DAKOTA DEPARTMENT OF TRANSPORTATION

BISMARCK, NORTH DAKOTA

Website: <http://www.discovernd/dot/>

DIRECTOR

David A. Sprynczynatyk

MATERIALS AND RESEARCH DIVISION

Ron Horner

EXPERIMENTAL PROJECT REPORT

EXPERIMENTAL PROJECT	EXPERIMENTAL PROJECT NO.					CONSTRUCTION PROJ NO		LOCATION																
	1	STATE ND	YEAR 95	-	NUMBER 03	SURF	IM-6-029(022)186 & 8 IM-8-029(003)022	Richland & Pembina 28 Counties																
SHORT TITLE	EVALUATION FUNDING																							
	48	1	X	HP&R	3	DEMONSTRATION		NEEP NO. []	PROPRIETARY FEATURE? X Yes 51 No															
THIS FORM	DATE	MO.	YR.	REPORTING																				
	140	1	0	-	2	0	0	1	1	INITIAL	2	ANNUAL	3	X	FINAL									
KEY WORDS	KEY WORD 1 145 Pavement Concrete					KEY WORD 2 167 Joints																		
	KEY WORD 3 189 Dowels					KEY WORD 4 211 Load Transfer																		
	UNIQUE WORD 233					PROPRIETARY FEATURE NAME 255																		
CHRONOLOGY	Date Work Plan Approved		Date Feature Constructed:		Evaluation Scheduled Until:		Evaluation Extended Until:		Date Evaluation Terminated:															
	June 1995 277		August 1995 281		August 2000 285		289		October 2001 293															
QUANTITY AND COST	QUANTITY OF UNITS				UNITS				UNIT COST (Dollars, Cents)															
	7635 297				1 LIN. FT 2 SY 3 SY-IN 4 CY 5 TON 6 LBS 7 x EACH 8 LUMP SUM 305				28.50 306															
AVAILABLE EVALUATION REPORTS	X CONSTRUCTION			X PERFORMANCE			X FINAL																	
	315																							
EVALUATION	CONSTRUCTION PROBLEMS					PERFORMANCE																		
	318	1	NONE	2	X	SLIGHT	3	MODERATE	4	SIGNIFICANT	5	SEVERE	319	1	EXCELLENT	2	GOOD	3	X	SATISFACTORY	4	MARGINAL	5	UNSATISFACTORY
APPLICATION	1 ADOPTED AS PRIMARY STD.					4 PENDING					(Explain in remarks if 3, 4, 5, or 6 is checked)													
	2 PERMITTED ALTERNATIVE					5 REJECTED																		
	320					3 ADOPTED CONDITIONALLY					6 NOT CONSTRUCTED													
REMARKS	321																							
	<p>Project IM-6-029(022)186; Patchroc 10-60 - Load transfer across the joints indicate an average of 42%. 21% of the joints evaluated have spalling, 21% of the joints evaluated are debonding and 100% of the joints evaluated are raveling.; Minnesota mix 3U18 - Load transfer across the joints indicate an average of 43%. 62% of the joints evaluated have shrinkage cracks, 21% of the joints evaluated are debonding and 0% of the joints evaluated are raveling.</p> <p>Project IM-8-029(003)022; Patchroc 10-60 - Load transfer across the joints indicate an average of 95%. 52% of all joints evaluated have spalling, 100% of the joints evaluated are raveling.</p>																							

Experimental Study ND 95-03

Dowel Bar Retrofit for Load Transfer

FINAL REPORT

Projects IM-6-029(022)186 & IM-8-029(003)022

October 2001

Written by
Curtis Dunn/Bryon Fuchs

Disclaimer

The contents of this report reflect the views of the author or authors who are responsible for the facts and the accuracy of the data presented herein. The contents do not reflect the official views of the North Dakota Department of Transportation or the Federal Highway Administration. This report does not constitute a standard, specification, or regulation.

TABLE OF CONTENTS

Objective	1
Scope	1
Location	2
Project History	3
Construction	3
Traffic	4
Design	5
Construction	6
Evaluation	10
Summary	30
Recommendation	32
Appendix A Construction Plans	A-1
Appendix B Special Provisions	B-1
Appendix C Load Transfer Graphs	C-1
Appendix D New Special Provision	D-1

Dowel Bar Retrofit for Load Transfer

OBJECTIVE

The objective of this study was to determine if dowel bar retrofitting would prevent faulting from recurring in jointed concrete pavement.

Field studies in the past have demonstrated the ability of retrofit load transfer devices to improve load transfer and delay additional faulting near the joint. Dowel bars are the most widely used load transfer device in new construction and have been installed in existing pavements to restore load transfer.

Many jointed plain concrete pavements were constructed without dowels at transverse joints. Load transfer across such joints was primarily accomplished through aggregate interlock. However, as the existing pavements became older, the volume of heavy truck traffic increased. The load increase coupled with temperature variations caused the joints to open wider with time and reduce the effectiveness of aggregate interlock.

SCOPE

In 1995, the North Dakota Department of Transportation incorporated test sections involving dowel bar retrofitting into projects IM-8-029(003)022 and IM-6-029(022)186. These test sections were evaluated for a period of six years. Items to be evaluated are:

1. Monitoring of distresses around the dowel bars.
2. Performance and comparison of the two concrete mixes used in the test sections.
3. Non-destructive deflection testing will be performed annually for load transfer across the doweled joints. This testing was accomplished with the use of a falling weight deflectometer (FWD).

Location

Project IM-6-029(022)186 was located on I-29 Southbound (SB) from the Drayton Interchange north to near the Bathgate Interchange and was 10 miles in length. The dowel bar retrofit experimental test section was approximately 3 miles in length and was located between station 1406+00 Rt and 1566+00 Rt.

Project IM-8-029(003)022 was located on I-29 SB lanes from the Mooreton Interchange to the Christine Interchange and was 21.7 miles in length. The dowel bar retrofit test sections were located in a consecutive five-mile stretch between milepoint 39 and 44.

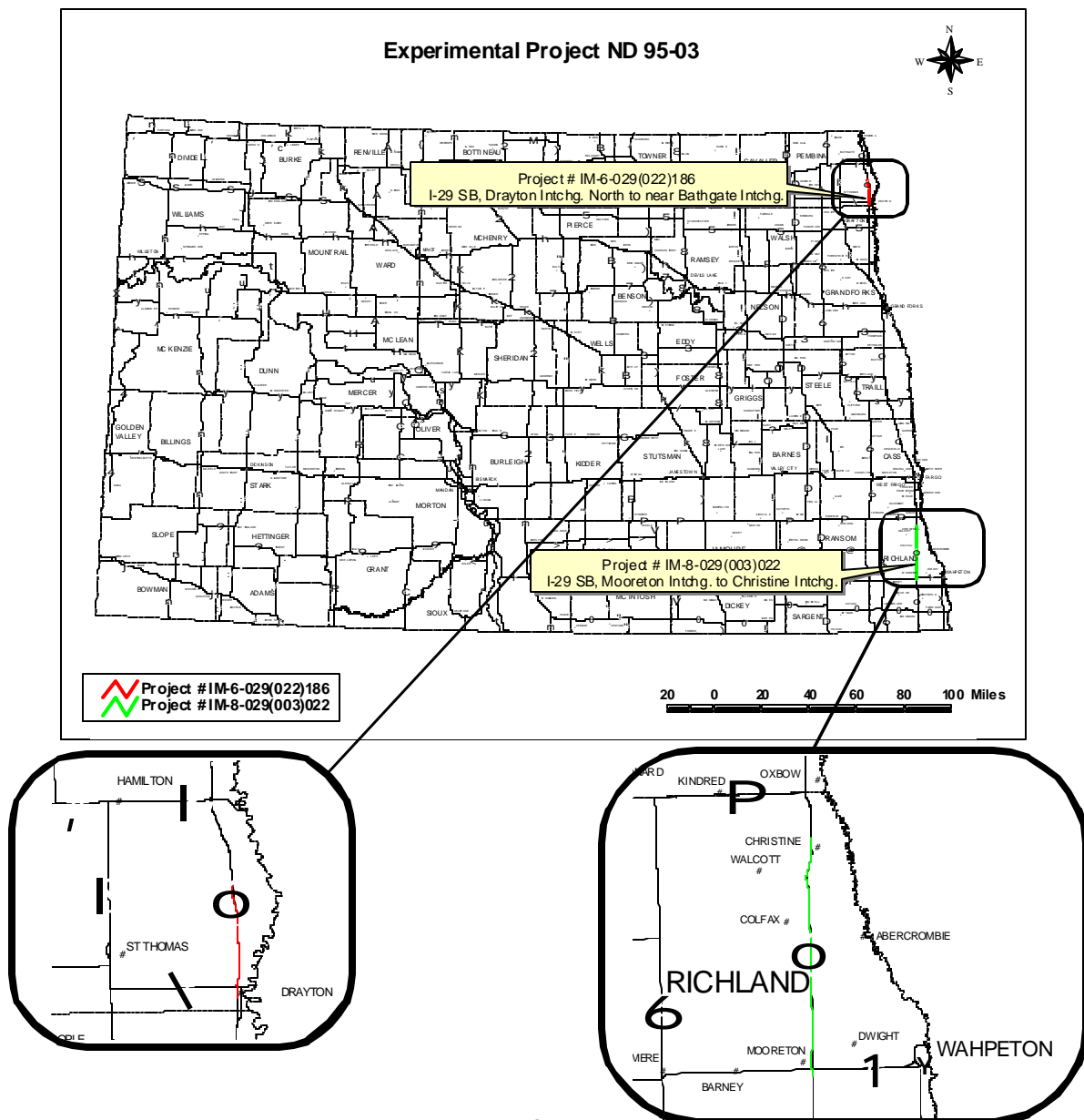

Project History

Construction

Table 1 shows the history of the pavement section prior to project IM-6-029(022)186 from mile 187 to 190 (SB).

Year Constructed	Type of Construction	Depth (in.)	Rdwy Width (ft.)
1976	Grade		48
1977	Lime Treated Subgrade	6.0	48
1977	Plant Mix Bituminous Base 85-100	2.0	41
1977	Non-Reinforced P.C.C.	9.0	24
1977	16 Foot Joints		
1977	Variable C-C		
1977	Inside Shoulder		3
1977	Outside Shoulder		10
1977	P.C.C. Shoulders	9.0	13
1987	Guardrail		
1995	Grinding		
3 Miles of Dowel Bar Retrofit			

Table 1.

Table 2 shows the history of the pavement section on project IM-8-029(003)022 from mile 39 to 44 (SB)

Year Constructed	Type of Construction	Depth (in.)	Rdwy Width (ft.)
1974	Grade		48
1975	Lime Treated Subgrade	6	48
1975	Plant Mix Bit. Base 85-100	2	41
1975	Plain Jointed P.C.C.	9	27
1975	16 Foot Joints		
1975	P.C.C. Shoulders	9	10
1995	Grinding		18
1995	Concrete Pavement Repair		37
1995	Dowel Bar Retrofit		

Table 2.

Traffic

Southbound one-way traffic estimates for project IM-6-029(022)186 are shown in

Table 3.

Year	Pass>Car	Trucks	Total	30th Hour	Rigid ESALs
1995	1,040	250	1,270	130	355
1996	825	455	1,280	130	645
1997	905	465	1,370	135	660
1998	935	505	1,440	145	725
2000	1,100	650	1,750	175	845

Table 3.

Southbound one-way traffic estimates for project IM-8-029(003)022 are shown in

Table 4.

Year	Pass>Car	Trucks	Total	30th Hour	Rigid ESALs
1995	1,970	430	2,400	290	570
1996	2,255	435	2,690	330	575
1997	2,360	560	2,920	360	740
1998	2,310	560	2,870	290	735
2000	2,225	575	2,800	280	800

Table 4.

Design

There were two types of mixes designed for use the projects. One was a proprietary mix and the other a specified mix. The proprietary mix was manufactured by FOSROC. The mix was called Patchroc 10-60. The specified mix was obtained from the Minnesota Department of Transportation (MnDOT). MnDOT identifies this mix as 3U18. The mix design for the 3U18 mix is included below:

The following mix design is for one cubic yard:

Cement	850 lbs
Water	295 lbs
Sand	1318 lbs
Course Aggr.	1341 lbs

The course aggregate gradation consisted of:

<u>Sieve</u>	<u>% Passing</u>
3/8"	100
#4	70-95

The following is the sand gradation:

<u>Sieve</u>	<u>% Passing</u>
#4	95-100
#8	80-100
#16	55-85
#30	30-60
#50	5-30
#100	0-10

Information regarding dowel bar material, curing compounds, and other materials used in the design of the dowel bar retrofit test sections is discussed in the special provisions located in Appendix B.

Construction

Project IM-6-029(022)186:

Construction of the dowel bar retrofits for IM-6-029(022)186 took place during the month of August in 1995. The prime contractor was Highway Services Inc. (HSI). The project engineer was Tom Lizakowski of the Grand Forks District. Materials and Research visited the site several times during and after construction.

The test sections involved three miles of the project. The work consisted of retrofitting epoxy-coated dowel bars into existing concrete pavement. The work conformed to the North Dakota Department of Transportation Special Provision "Dowel Bar Retrofit."

The dowel bars were placed in the driving lane of the southbound roadway. Two sets of three evenly spaced dowel bars were placed across each transverse joint in question. One set for each wheel path.

The north half of the test section was placed using the FOSROC product Patchroc 10-60. The south half of the test section was placed using the Minnesota specified mix 3U18.

The project engineer commented that the Minnesota specified 3U18 patch mix appeared to have a drier consistency compared to the Patchroc 10-60 and was easier to work with.

Mr. Lizakowski also commented that the Patchroc 10-60 material sets up at a very fast rate. It was suggested that other types of mixes should be researched for use in place of the above mixes.

Several cores were taken shortly after the test sections were constructed. It was determined from the cores taken that insufficient vibrating of the mix had caused voids under the dowel bars.

Photo 1 provides a view of these voids which were evident in the sections where the Patchroc 10-60 mix was used.



Photo 1. View of several cores taken by the Grand Forks District

Materials and Research checked the joints with the FWD after the Grand Forks District discovered several cores with voids in them. Materials and Research had previously conducted an analysis before the installation of the dowel bars.

Generally, load transfer before the dowel bars were installed was between 20% to 30%. After the dowel bars were installed the average load transfer was approximately 76%. This percentage was reflected across joints located in the section containing the Patchroc 10-60 mix and the section containing the Minnesota specified mix 3U18.

It was determined that the contractor would redo any areas with less than 50% load transfer. The contractor ended up replacing 120 dowels or about 2% of the total dowels. All of the replacement dowels were located on stations that used Patchroc 10-60.

Another problem that was encountered on project IM-6-029(022)186 was the inadequate design of the foam core board. The purpose of the core board was to provide a way for the existing transverse joint to stay free of patching material during its placement. While placing the patch mix, the core board was failing to stay vertically stable. Except for the problems mentioned above, the construction of project

IM-6-029(022)186 went well.

Project IM-8-029(003)022:

Project IM-8-029(003)022 was constructed about two weeks later than the dowel bar retrofit project in the Grand Forks District. This gave project engineer, Troy Gilbertson, time to evaluate the performance of the earlier section and to determine if any changes could be made to solve any of the problems related to that project.

One of the changes involved the patch mix. After the problems the Grand Forks District was experiencing with the Minnesota specified mix 3U18, the Fargo District decided to use Patchroc 10-60 for the entire project. One of the main reasons for the change was the lack of non-shrink cement material in the 3U18 patch mix. This may have been part of the reason for the shrinkage problems experienced on the Grand Forks project.

The core board design used in the Grand Forks project did not perform well. While placing the patch mix, the core board was failing to stay vertically stable. It was recommended that the core board be redesigned to include extensions on the upper portion of the core board. The extensions on the upper portion of the core board would extend into and parallel to the existing joint. This would insure the core board would run parallel in the joint and would not tilt when the sawed slot is filled with Patchroc 10-60 mix.

Other changes were made regarding the width of the dowel bar retrofit slot. The slot would be narrowed to 2 ½" instead of 3". Also, the location of the dowel bars near the 10' shoulder has been shifted 6" further away from the longitudinal shoulder joint.

Another change that was made to the dowel bar retrofit special provision was the type of dowel bar bond-breaker coating that was to be applied to the dowels. The type of material originally specified was a black asphaltic material manufactured by Valvoline Oil Company. This material was difficult to work with in the field. A white water base with a wax curing compound was substituted as the bond-breaker material. Several cores were taken on the Fargo project. All of them appeared to be in good condition. The bottom of the bar was well seated and vibrated sufficiently to allow the mix to flow underneath the dowel bars. The bond along the existing concrete edge and

the Patchroc 10-60 also looked good.

Materials and Research conducted an FWD analysis before and after the installation of the dowel bars. The results showed that before the dowel bars were installed, load transfer was approximately 20% to 30%. After the dowel bars were installed, results indicated an average load transfer of approximately 85%. No areas were found to have less than 50% load transfer.

The Fargo District recommend that the Department of Transportation redesign the foam core boards to a T shape for future projects. They recommended a change in the thickness of the board to 3/8" thick, run the core board to the top of the slab, and have the contractor remove excess sealant where the extensions will set in the joint. Figure 1 shows the proposed change.

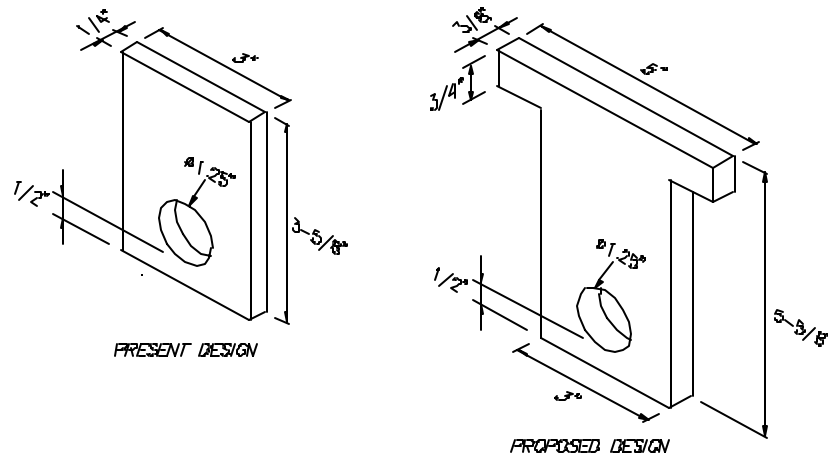

Figure 1

In general, Mr. Gilbertson said there were no problems with the contractor on this project.

Evaluation

Project IM-6-029(022)186:

Materials and Research conducted the final visual observation of project IM-6-029(022)186 on August 28, 2001. Monitoring of distresses around the dowel bars, and comparing the two concrete mixes used in the test sections were of prime importance.

Pachroc 10-60

Materials and Research began the evaluation on the north end of the project. As previously mentioned the patching material Patchroc 10-60 was used on the north half of the project.

Photo 2 depicts an overall view of the dowel bar retrofit test section. This photo indicates a segment of the test section where Patchroc 10-60 had been installed as the patch mix.



Photo 2. An overall view of the dowel bar retrofit section.

As noted in the previous performance reports there were isolated areas within the test section that were experiencing several types of distresses.

One kind of distress that was prevalent is shown in photo 3. There were several dowel bar slots experiencing this type of distress. In many cases the mix located between the adjacent joint and the transverse crack is loose. It is believed this type of distress is the result of poor consolidation of the mix around the dowel bar.

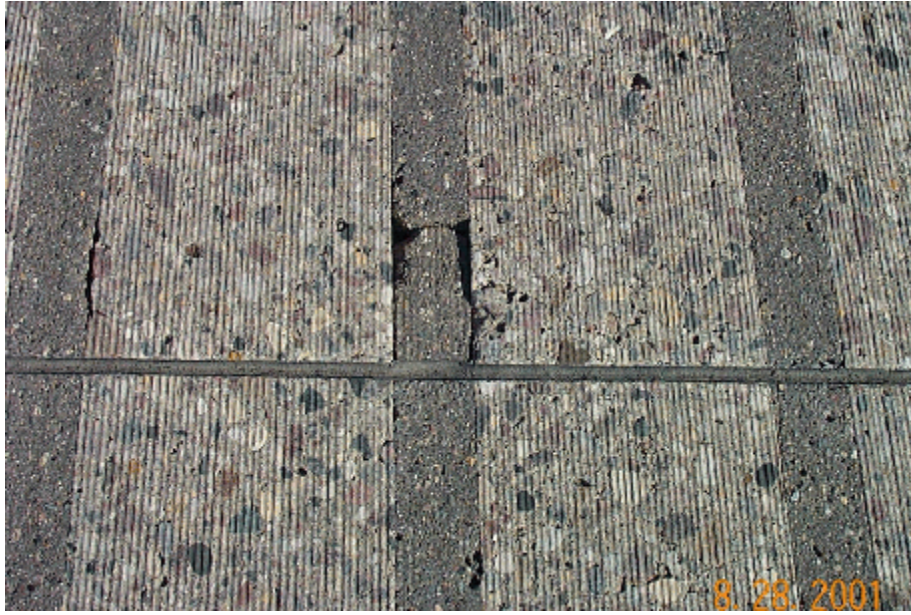

Photo 3. Typical distress detected during 2001 evaluation (A portion of the test sections containing Patchroc 10-60 patching material)

This type of distress is sometimes confused with the distresses related to core board failures.

Distress related to core board failures as shown in photo 4 is also detected on one side of the joint and extends outward approximately 1" to 2". It is believed that as the patch mix was being placed the weight of mix would bend the core board over. The original core board design is shown back in Figure 1. Once the core board was forced to yield one way or the other, the patch mix would then be free to cover the core board. This condition left the core board sitting on a slant or in some cases horizontal with upwards to 2" of mix being placed on top the foam core board. When traffic was allowed to pass over the roadway, the corresponding loads may have forced the mix to shear at these areas since there was no support underneath the mix.



Photo 4. A view of a typical distress caused by a core board failure

Another type of distress observed in the test section containing the Patchroc 10-60 relate to the performance of the mix. Photos 5 and 6 depict views of typical dowel bar slots in the Patchroc 10-60 section that is experiencing deterioration of the mix. Photo 5 depicts the most common failure, deterioration near the panel joint. Photo 6 provides a view of a failure some distance from the panel joint.

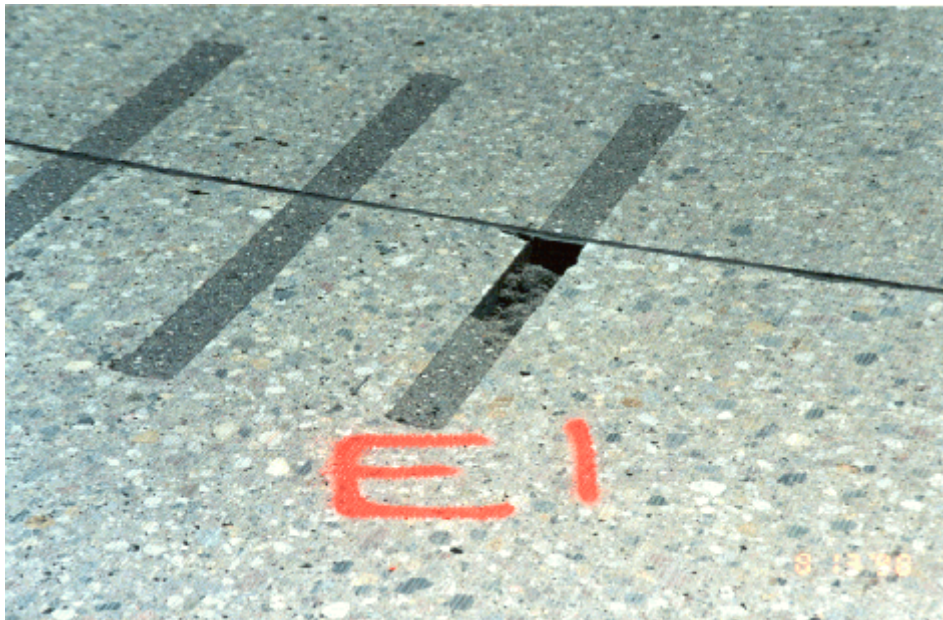

Photo5. Patchroc 10-60 mix deterioration near panel joint

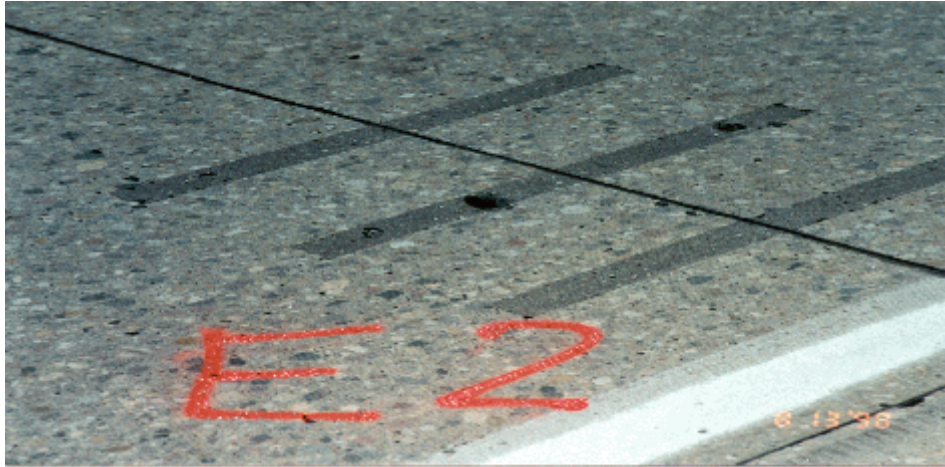

Photo 6. Patchroc 10-60 section experiencing mix deterioration

Photo 7 shows an overview of several sets of dowel bars slots located in the outside wheelpath of the Patchroc 10-60 section which are affected by deterioration of the mix. Notice in photo 7 that the traffic has worn down the material in the slots. They are now recessed relative to the surrounding pavement surface. This can also be seen by a slight shadow shown on the left edge of each slots in photo 7. Also notice that the inside lane does not appear to be as severe.



Photo 7. Dowel bars slots located in the outside wheel path of the Patchroc 10-60 section

Photo 8 is a close-up view of some of the dowel bars slots affected by the mix problem



Photo 8. Close-up view of photo 7 dowel bars slots affected by mix problem

previously described.

As shown in the last several photographs, problems related to the mix fall into different severity levels. The problems occurring in photos 7 and 8 appear to be the

result of wear over an extended period of time. Whereas other mix problems tend to show up much quicker.

Another type of distress that is present in the Patchroc 10-60 test section is shown in photo 9. Notice the distresses present on near both sides of the joint and also the severe raveling of the mix. The distress (Patchroc material missing) located at the joint is believed to be a bonding issue. The special provision calls for caulk to be placed in the bottom of the slot and the sides along the joint so patch material does not enter the joint. If care is not taken, some

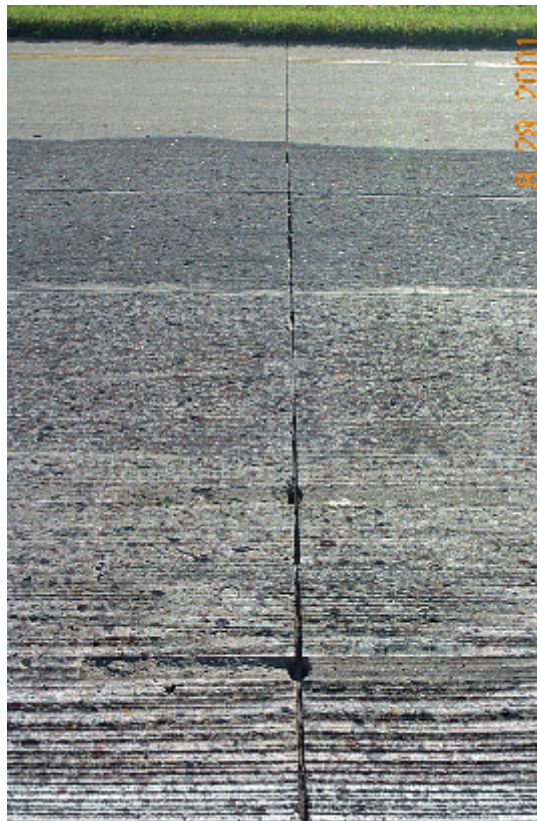

Photo 9. Note the severe raveling and the debonding along the joint.

of the caulk will end up on the sides of the slots and create a bonding problem. The severe raveling of the mix is a durability problem within the mix itself. A similar type of distress has been detected in the Fargo District.

The joints in one random 1000' segment of the test section containing the Patchroc 10-60 was evaluated for frequency of distresses in general. The segment

contained approximately 66 joints. Refer to Table 5 for distresses noted in the test segment.

Percent of Patchroc 10-60 joints (Evaluated 66) that have experienced Distresses noted below.					
Popouts	Raveling	Debonding	Coreboard Failures	Spalling	Shrinkage Cracks
77.3%	100%	21.2%	6.1%	21.2%	0%

Table 5

In general, nearly all of the distresses present in the sections containing the Patchroc 10-60 material appears to be either related to the mix, bonding, core board failures, or improper vibration of the mix (as determined by the cores taken by the Grand Forks District, refer to photo 1 on page 7). However, virtually all of these distresses could be avoided with proper control of construction practices.

3U18 Patch Mix

The south half of the test section contains the Minnesota specified mix 3U18 as the dowelbar retrofit patch material. Photo 10 shows a typical retrofitted joint where this mix was used.



Photo 10. Typical retrofitted joint where 3U18 mix was used. Note the shrinkage crack in the 3rd joint.

As reported in previous evaluations, the test section containing the 3U18 mix is also experiencing several of the distresses present in the portion containing the Patchroc 10-60 material. One distress not seen in the Patchroc 10-60 section that is prevalent in the section containing the 3U18 mix is shrinkage cracks running transverse and longitudinal to the dowel bar slots. These distresses are fairly common within the

section.

Photo 11 shows dowel bar slots affected by several types of distresses including the shrinkage cracks. Notice how the transverse cracks do not follow any distinctive pattern as to how far away from the joint they exist. Photo 11 also illustrates a view of a large piece of patch mix that is missing from the slot. The dowel bar is exposed and has to some extent rusted. At a glance it appears that the mix may have been improperly vibrated and the consolidation did not occur around the dowel bar causing the concrete to break out.



Photo 11. Dowel bar slots filled with 3U18 patch mix affected by several types of distresses including the shrinkage cracks.

The joints in one random 1000' segment of the test section containing the Minnesota 3U18 mix was evaluated for frequency of distresses in general. The segment contained approximately 66 joints. Refer to Table 6 for distresses noted in the test segment.

Percent of Minnesota 3U18 joints (Evaluated 66) that have experienced Distresses noted below.					
Popouts	Raveling	Debonding	Coreboard Failures	Spalling	Shrinkage Cracks
18.2%	0%	21.2%	28.8%	10.6%	62.1%

Table 6

In general, nearly all of the distresses present in the section containing the Minnesota 3U18 material appears to be either related to the mix, bonding, core board failures, or improper vibration. However, virtually all of these distresses could be avoided with proper control of construction practices.

Mix Comparisons

Mix problems whether construction related or within the mix itself is prevalent in both mixes. However, the 3U18 mix is not experiencing the eroding or raveling of the mix as seen the Patchroc 10-60 sections. It appears the 3U18 material is performing better than the Patchroc 10-60 material from a standpoint of durability. Photo 12 shows a view of the border between the two different patch mixes. In the foreground is the slots containing the Patchroc 10-60 material and the later the 3U18 material. At a glance it would appear, from an aesthetic standpoint, that the color of 3U18 material blends into the existing PCC much better than its counterpart.



Photo 12. View of both dowel bar patch materials. Patchroc 10-60 material in foreground, followed by the 3U18 material

FWD comparison testing

Materials and Research conducted non-destructive deflection testing for load transfer across the doveled joints in the outside wheel path. This testing was accomplished with the use of a Falling Weight Deflectometer. Testing was done randomly on joints in both the Patchroc 10-60 mix section and the Minnesota specified mix 3U18 section. The sections containing the Patchroc 10-60 patch mix showed an average load transfer of approximately 42% in 2001 as opposed to an average load transfer of approximately 69% in 1996. The sections containing the Minnesota specified mix 3U18 showed an average load transfer of approximately 43% in 2001 as opposed to an average load transfer of approximately 55% in 1996. As noted, both sections are registering significantly lower readings as compared to earlier readings. A representative segment of roadway indicating the decline in load transfer percentages between the years 1996 to 2001 is presented in Table 7 and Table 8. For a representative section of roadway, these percentages are relatively low compared to project IM-8-029(003)022 as will be seen later in the report.

Patchroc 10-60							
TESTLOC	1995(before)	1995(after)	1996	1997	1998	2000	2001
189+4904	20.08	79.78	81.6	84.6	80.7	70.8	56.6
189+4888	23.49	86.85	73.8	45.5	43.7	86.7	77.7
189+4872	22.63	86.29	77.0	82.2	90.4	90.3	93.2
189+4856	25.62	83.66	81.3	81.4	83.9	51.7	42.4
189+4841	28.42	77.77	74.9	59.1	37.5	36.5	29.5
189+4827	25.91	78.82	56.0	57.6	55.0	48.3	40.7
189+4814	43.13	85.81	71.1	82.5	89.5	86.9	91.5
189+4798	23.26	83.37	66.7	60.5	55.5	28.5	29.3
189+4783	23.98	71.58	75.3	80.0	82.9	67.9	47.5
189+4765	25.44	76.66	68.6	67.3	51.2	28.0	29.5
189+4750	26.20	75.72	58.9	46.3	38.4	24.2	31.2
189+4731	26.17	82.51	70.0	67.0	77.8	51.2	38.3
189+4715	22.38	68.13	72.5	69.4	66.7	46.2	37.3
189+4699	23.40	72.50	63.1	50.3	47.1	37.8	34.2
189+4683	25.17	68.64	64.1	56.8	62.3	41.1	33.9
189+4667	25.11	71.56	66.5	51.6	30.5	27.1	29.42
189+4650	26.28	64.89	62.9	58.9	39.3	25.4	28.94
189+4632	23.25	81.95	61.8	53.9	37.4	30.7	29.5
189+4616	22.59	79.57	77.9	58.4	42.3	27.6	29.8
189+4602	22.97	87.36	81.5	79.7	60.4	33.1	28.6
189+4586	23.43	84.91	79.4	75.3	62.5	30.7	34.1
189+4568	30.81	77.98	77.9	89.6	86.8	73.3	84.6
189+4554	31.99	53.36	59.5	62.2	38.6	29.6	22.76
189+4540	26.33	51.63	42.2	33.1	23.9	30.8	28.2
189+4524	29.95	77.89	56.6	44.2	42.5	35.0	27.48
189+4509	36.63	79.65	66.8	75.0	61.8	48.7	30.1
Average	26.33	76.49	68.76	64.31	57.26	45.70	41.78
Increase(%)		50.16	-7.74	-4.45	-7.05	-11.56	-3.92

Table 7

Minnesota 3U18 Mix						
TESTLOC	1995(before)	1996(after)	1997	1998	2000	2001
188+4906	21.49	59.9	40.4	73.8	30.00	28.00
188+4889	22.62	45.8	38.9	30.1	32.90	48.10
188+4874	23.34	52.1	53.5	46.4	38.90	60.90
188+4860	23.03	50.8	31.7	31.6	49.90	47.30
188+4843	23.72	56.8	44.4	36.3	43.30	45.90
188+4827	22.79	38.1	38.9	26.6	33.50	25.40
188+4813	21.37	61.3	64.1	51.2	83.50	64.80
188+4796	21.86	73.7	85.3	42.4	40.60	55.50
188+4780	19.69	58.3	73.1	46.6	40.20	40.50
188+4762	20.45	53.4	58.5	50.7	40.50	42.00
188+4748	24.95	63.7	49.3	36.3	35.10	31.90
188+4733	25.76	48.9	37.2	28.8	31.50	30.40
188+4720	21.89	60.5	44.8	32.5	34.20	31.00
188+4706	23.39	63.1	51.3	37.4	30.60	37.20
188+4689	22.09	40.7	31.5	31.3	31.90	30.40
188+4674	20.79	36.3	29.5	29.9	31.60	41.20
188+4656	21.15	41.5	33.1	31.9	31.80	29.50
188+4641	21.04	56.7	82.6	35.9	71.00	77.90
188+4626	22.82	41.8	36.2	31.8	44.90	42.50
188+4610	19.55	45.8	46.8	34.8	45.90	44.50
188+4592	20.75	72.8	64.7	35.1	39.00	66.20
188+4576	21.32	62.2	36.8	31.5	28.90	28.90
188+4562	21.32	44.1	43.1	33.3	38.60	34.30
188+4544	24.13	76.4	60.5	37.2	72.00	57.80
188+4531	20.94	62.2	50.1	36.2	38.70	34.60
188+4513	22.69	50.2	41.2	31.8	40.20	51.40
Average	22.11	54.50	48.75	37.35	41.51	43.39
Increase(%)		32.39	-5.75	-11.40	4.16	1.88

Table 8

Project IM-8-029(003)022:

Materials and Research conducted the final visual inspection of project IM-8-029(003)022 on September 12, 2001. Monitoring of distresses around the dowel bars, and evaluating the performance of the patching material was of prime importance. The patching material Patchroc 10-60 was used exclusively on project IM-8-029(003)022.

Photo 13 illustrates a typical dowel bar retrofitted joint that appears to be performing well. Photo 14 illustrates a typical dowel bar retrofitted joint that appears to be performing well.



Photo 13. Typical dowel bar retrofitted joint that appears to be performing well. The longitudinal crack has not caused distress to the dowel bar patch mix.

Photo 14 shows a view of several distresses that are believed to be the result of excess silicone caulk on the slot walls prevented bonding between the existing concrete and the patching material.

The bond failure is causing high stresses in a small area near the joint resulting in spalling. The types of distresses shown in photo 14 are sometimes confused with distresses that are related to core board failures (usually affecting only one side of the joint).



Photo 14. View of several distresses that are believed to be the result of excess silicone caulk on the slot walls prevented bonding between the existing concrete and the patching material.

Photo 15 shows the core board in an upright manner.

Many of the other distresses present in the inspection of the dowel bar retrofit sections in the Grand Forks District were also present in the Fargo District.

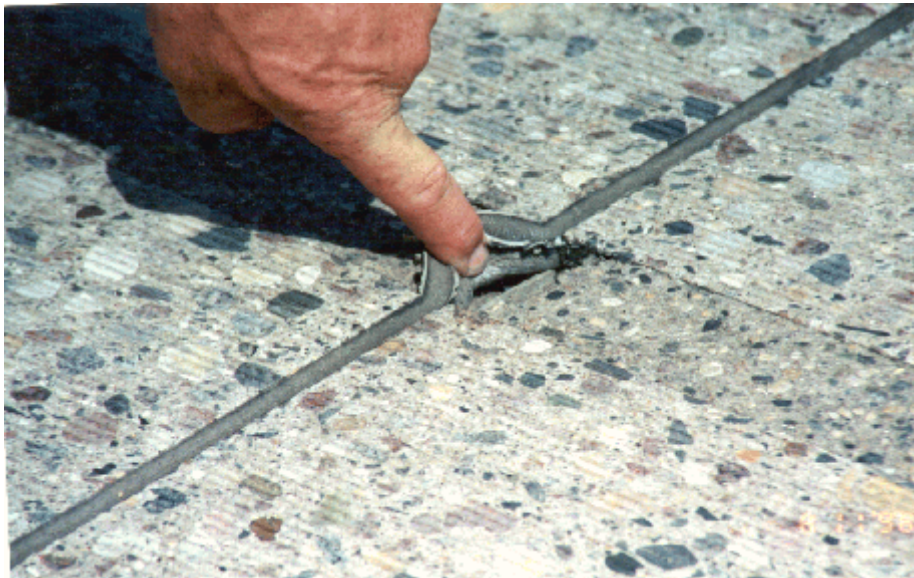

Photo 15. A close-up view of one of the dowel bar slots in photo 14.

Photo 16 indicates an area that is experiencing mix problems in the dowel bar slots. Also in photo 16, traffic has wore down the material in the slots to a point where it is no longer the same elevation as the existing concrete.



Photo 16. An area that is experiencing mix problems in the dowel bar slots.

Photo 17 shows a view of dowel bar slots where an effort has been made to repair the mix that has eroded away from the slot. It is not determined at this point if this type of repair will be successful in keeping the distresses from worsening.

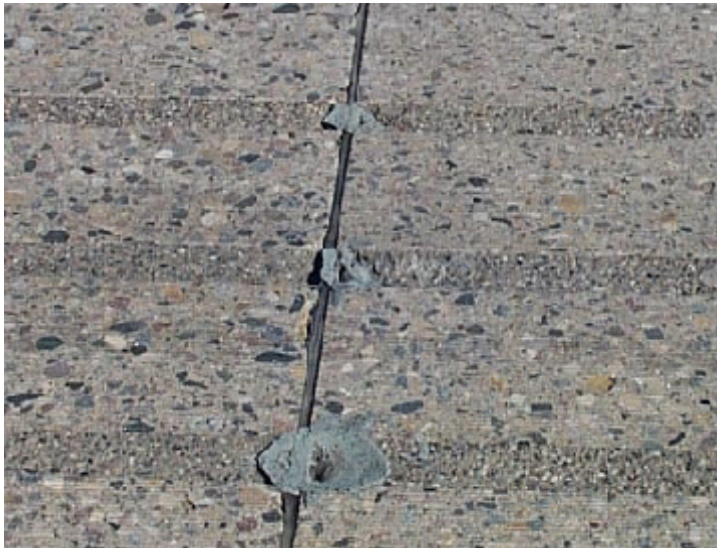

Photo 17. Dowel bar slot that was filled with a sealer in an attempt to seal out water and prevent further distresses from occurring.

The joints in one random 1000' segment of the test section containing the Patchroc 10-60 mix was evaluated for frequency of distresses in general. The segment contained approximately 67 joints. Refer to Table 9 for distresses noted in the test segment.

Percent of Patchroc 10-60 joints (Evaluated 67) that have experienced Distresses noted below.					
Popouts	Raveling	Debonding	Coreboard Failures	Spalling	Shrinkage Cracks
100%	100%	0%	5.9%	52.2%	0%

Table 9

It is believed that nearly all of the distresses that are prevalent in the Fargo District test sections are construction related and could be avoided with proper control of construction practices.

In general, except for the distresses mentioned above, the dowel bar retrofit test sections in both wheel tracks appear to be in fair shape.

FWD Testing

In 2001, Materials and Research conducted non-destructive deflection testing for load transfer across the doweled joints in the outside wheel path. This testing was accomplished with the use of a Falling Weight Deflectometer. The same joints tested in 1995 (after construction) were also tested in 2001. The testing completed in 2001 averaged a load transfer of approximately 95.2%. Testing completed on these same joints in 1995 averaged a load transfer of approximately 86.4%. A representative segment of roadway showing an increase in load transfer percentages between the years 1995 to 2001 is presented in Table 10.

At this point in the evaluation it is apparent that this dowel bar retrofit test section is sustaining its ability to transfer the traffic loads across the joints.

Patchroc 10-60					
TESTLOC	1995(before)	1995(after)	1998	1999	2001
42+5274	24.12	83.29	95.6	93.40	96.50
42+5257	26.04	81.41	92.5	94.50	93.50
42+5243	21.48	90.40	93.0	95.10	94.80
42+5222	20.72	87.78	90.5	91.60	90.80
42+5202	19.89	81.44	92.2	95.00	94.20
42+5186	21.98	74.73	87.6	92.90	91.20
42+5172	21.95	88.81	94.7	95.00	96.10
42+5156	23.57	88.39	93.7	95.00	97.00
42+5137	25.95	86.48	95.4	94.20	95.70
42+5120	110.86	86.27	93.5	93.40	95.60
42+5106	19.61	84.07	95.4	95.10	96.00
42+5090	20.27	92.08	94.0	94.70	96.70
42+5069	25.20	86.72	88.1	94.80	95.10
42+5053	26.06	90.21	94.1	96.30	96.50
42+5038	25.32	88.92	95.0	96.10	95.80
42+5022	21.19	89.50	92.6	96.00	96.70
42+5004	26.65	83.14	94.7	96.20	97.10
42+4988	22.57	87.33	92.7	94.50	94.50
42+4974	28.23	91.27	90.7	95.70	94.10
42+4957	23.63	88.65	93.1	93.60	94.50
42+4940	22.75	83.84	89.3	92.70	94.30
42+4923	19.71	87.87	96.0	94.00	97.90
42+4908	21.95	81.95	93.8	95.50	96.30
42+4891	20.14	90.78	92.0	93.00	96.30
42+4872	23.66	84.00	89.2	94.00	94.10
Average*	23.03	86.38	92.75	94.54	95.24
Increase(%)		63.35	6.38	1.78	0.70
*Datapoint 42+5120 not included					

Table 10

Summary

Project IM-6-029(022)186:

Sections containing Patchroc 10-60 material

Every joint in the 1,000' segment that was evaluated is experiencing at least one type of distress in their corresponding dowel bar slots. Distresses related to displaced core boards, durability of the mix (raveling and erosion), insufficient vibration (as determined by the cores taken by the Grand Forks District, refer to photo 1 on page 7), or excess sealant caulk are prevalent in the Patchroc 10-60 mix. FWD analysis shows approximately 42% load transfer in this segment which is significantly lower than originally constructed. Performance of the test section containing the Patchroc 10-60 material is poor. The poor performance can be attributed to the mix material and poor construction.

Sections containing 3U18 patch mix

Approximately 62% of the joints in the 1,000' segment evaluated is experiencing at least one type of distress in their corresponding dowel bar slots.

Some of the retrofit sections containing the Minnesota specified mix 3U18 are experiencing similar distresses as those related to the sections containing the Patchroc 10-60 mix. The retrofit sections containing the Minnesota specified mix 3U18 also experienced mix problems in the form of shrinkage cracks along the edge between the mix and the existing PCC. At this time, this section does not appear to show any signs of eroding or raveling of the mix which may indicate greater performance from a standpoint of durability.

FWD analysis shows approximately 43.4% load transfer in this segment which is lower than originally constructed.

Performance of this test section containing the Minnesota specified mix 3U18 patch mix is fair. The fair performance is attributed primarily to poor construction.

Project IM-8-029(003)022:

Every joint in the 1,000' segment evaluated is experiencing at least one type of distress in their corresponding dowel bar slots.

Distresses related to core board failures, durability of the mix (raveling and erosion), or excess sealant caulk are prevalent in the Patchroc 10-60 mix.

The average load transfer across the joints is approximately 95%. As opposed to the Grand Forks test sections the Fargo test section appears to be sustaining its ability to transfer traffic loads across the joints.

Performance of this test section is good with one exception, durability. This test section appears to have had better construction as noted with the low number of construction related distresses and the load transfer is excellent.

The problems associated with the raveling of the Patchroc 10-60 material appears to be in the mix itself and not related to construction.

Recommendation

Dowel bar retrofit has proven to be an effective way to restore load transfer in PCC pavements provided proper methods are used. Poor construction however will lead to decreasing load transfer efficiency within the first several years after construction.

As a result of these projects, the NDDOT has moved forward with dowel bar retrofitting on PCC pavements as a way to restore load transfer with the following changes. A copy of the most current special provision is provided in the Appendix.

1. The core board thickness was change from 1/4" to 3/8" to stiffen the material. This decreases the chance of the core board falling over when the mix is placed in the slot.
2. The previous specifications called for 6.0 sacks or bags of cement per cubic yard and a maximum of 5.1 gallons of water per bag of cement. The patching material now shall have a minimum compressive strength of 4,000 psi in six hours. Cylinders are cast to check the compressive strength in six hours.
3. A mobile mixer was previously allowed, however due to inconsistent mix, a mobile mixer is no longer allowed. The patching material is now mixed using a batch process that has a water metering device. This has enabled the patching material to be more consistent.
4. A curing compound was previously specified but a time limit was added to the specification. The curing compound shall now be applied within 30 seconds after a set of 3 dowel bar patches have been finished. This process reduces the chances of the patching material to shrink.

It is recommended that dowel bar retrofit projects move forward as a way to restore load transfer in PCC pavements provided close scrutiny and adherence to the specifications are met during construction

Appendix A

DESIGN DATA				
Traffic	Average Daily			Est. Max/hr.
Current 1995	Pass. 1040	Trucks 250	Total 1290	235
Forecast 2015	Pass. 1560	Trucks 375	Total 1935	350
Minimum Sight Dist. for	Design Speed 80 MPH			
Stopping	1050'	Bridges		
Safe Passing	Sta. 1142+85, HS-20-44			
Passing for Marking	Sta. 1463+80, HS-20-44			

Traffic Classification "M"
 Full Control of Access
 No Point of Access Other Than By Ramps At Interchanges.

NORTH DAKOTA DEPARTMENT OF TRANSPORTATION

FEDERAL AID PROJECT NO. IM-6-029(022)186 (W. RDWY)
 IN
 PEMBINA COUNTY
 GRINDING AND CONCRETE REPAIR

JOB# _____

FHWA REGION	STATE	PROJECT NO.	SHEET NO.
8	ND	IM-6-029(022)186	1

GOVERNING SPECIFICATIONS:

Standard Specifications adopted by the North Dakota Department of Transportation September 1992. Standard Drawings currently in effect and other Contract Provisions submitted herein.

LENGTH OF PROJECT

	MILES-GROSS	MILES-NET
IM-6-029(022)186	10.003	9.977

.026 Mile deducted for bridges

End Project IM-6-029(022)186
 Sta. 1045+86.65 Sec. 35, Twp. 161N,
 Rge. 51W.

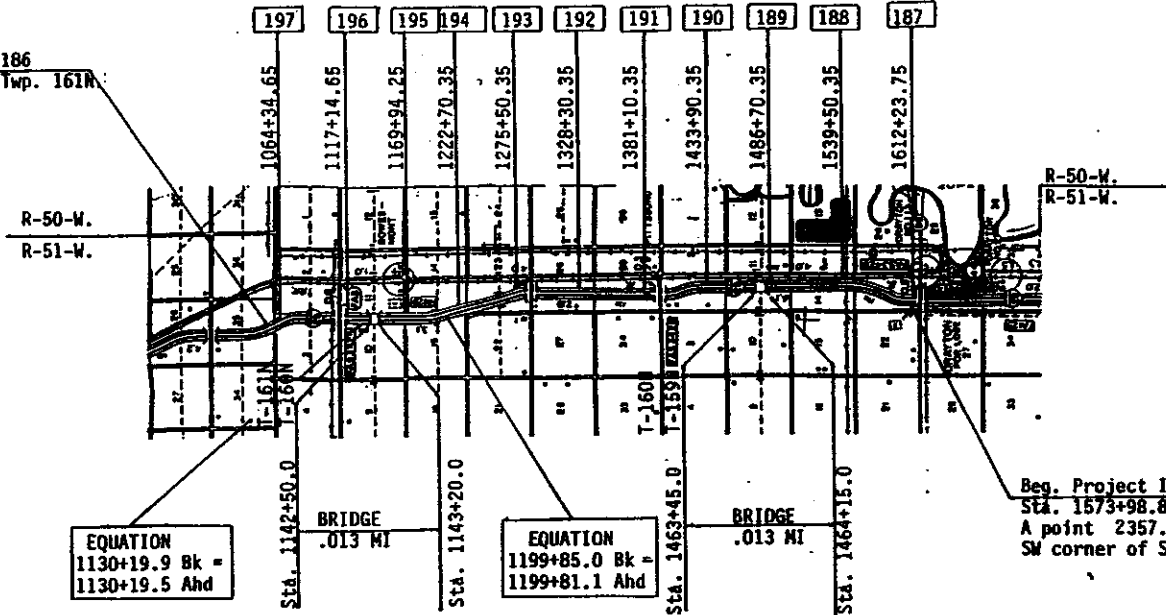

Begin Project IM-6-029(022)186
 Sta. 1573+98.8 Bk = Sta. 1593+92.2 Ahd
 A point 2357.4' N and 1298.5' E of the
 SW corner of Sec. 23, Twp. 159 N., Rge. 51 W.

A-2

PAVING SECTION	<i>Grind Resin</i>
URBAN SECTION	_____
TRAFFIC SECTION	_____
RURAL SECTION	_____
RECOMMEND APPROVAL	_____, 19__
DESIGN ENGINEER	_____

U.S. DEPARTMENT OF TRANSPORTATION
 FEDERAL HIGHWAY ADMINISTRATION

APPROVED

DIVISION ADMINISTRATOR DATE

APPROVED DATE _____

DIRECTOR OF HIGHWAYS
 AND ENGINEERING

NORTH DAKOTA
 DEPARTMENT OF TRANSPORTATION

TABLE OF CONTENTS

FHWA REGION	STATE	FED. AID PROJ. NO.	SHEET NO.
8	ND	IM-8-029(003)022	2

<u>SHEET NO.</u>	<u>DESCRIPTION</u>
1	Title Sheet
2	Table of Contents
3	Scope of Work
4-10	Notes
11-13	Quantity Sheets
14	Basis of Estimate
15-26	Repair Data Sheets
27-28	Concrete Pavement Repair (Full Depth)
29	Detail for Removal of Concrete at Joint Repair Locations
30	Dowel Bar Placement - Full Depth Repairs
31	Joint Details
32	Joint and Random Crack Cleaning and Sealing
33-34	Spall Repair Details
35	Retrofit Dowel Bar Installation
36	Bridge Approach Slab Repair
37-40	Pavement and Subgrade Repair at RCB
41	Traffic Control Phasing for Subgrade Repair Locations
42-45	Typical Surfacing at Bridge Ends with Guardrail
46-48	Mooreton Weigh Station Milling and Overlay
49-78	Guardrail
79-86	Mooreton Truck Scale
87-97	Bridge End Post Modification
98	Construction Sign Layout at Ramp
99-100	Additional Signing for Overwidth Vehicles
101	Traffic Control Devices List

LIST OF STANDARD DRAWINGS

<u>STANDARD NO.</u>	
D-704-8, 9, 10, 11, 12	Construction Sign Details
D-704-13	Barricade Details
D-704-14	Construction Sign and Barricade Assembly Details
D-704-15	Construction Sign and Barricade Location Details
D-704-18	Sign Layout for One-Lane Closure Interstate System
D-704-32	Sign Layout for One-Lane Closure Divided Highway Moving Operation
D-704-35	Sign Layout for One-lane Closure Interstate System
D-704-42	Road Construction Guide Sign
D-708-2	Temporary Erosion and Siltation Controls
D-748-9	Portable Precast Concrete Median Barrier
D-762-2	Interstate Pavement Marking
D-762-4	Pavement Marking
D-764-1	Bean Guardrail Details
D-764-2	Modified Eccentric Loader Terminal
D-764-2A	Diaphragm Buffered & Strut & Yoke Details
D-764-3	V Bean Guardrail at Bridge End (General Layout & Details)
D-764-5	V Bean Guardrail at Bridge Ends
D-764-8	Guardrail at Bridge Ends (60 MPH)
D-764-9	Guardrail at Bridge Ends (70 MPH)
D-764-12, 13	Typical Grading at Bridge Ends
D-764-32	Three Cable Guardrail
D-764-36	Three Cable Guardrail at Hazards (70 MPH Design Tables)

GENERAL NOTES

FWSA REGION	STATE	FED. AID PROJ. NO.	SHEET NO.
8	N.D.	IM-8-029(003)022	5

550/220 (Cont)

b. Centerline joint steel, on repairs exceeding 15' in length, will be treated as follows:

1. Each half of existing bars may be exposed independently and repoured to leave the existing bar in its original location.
2. "J"-Bolts or new #5 x 2'-6" tie-bars may be installed in the joint before the second half of the repair area is poured to establish the original tie-bar pattern and steel cross-sectional area. If the contractor chooses to install new tie-bars, the tie-bars shall be installed by drilling and grouting with a high-viscosity epoxy meeting the requirements of AASHTO M-235, Class III.

550 REINFORCING STEEL: The cost for all steel used for reinforcing, 230 bar supports, J-bolts, and tie bars will not be a separate pay item but shall be incidental to the price bid for "9 In. Concrete Pavement Repair (Full Depth - Doweled)."

550 DAMAGED AREAS: Any repair areas that are damaged in any manner 280 during the curing period shall be replaced by the contractor at his expense. If a repair area needs to be lengthened due to damage caused by the contractor's operation, the repair of the lengthened portion shall be at the contractor's expense. If this lengthening occurs where the adjacent lane is to remain and saw cuts extending into the lane to remain occur less than 12 inches apart, the area between these saw cuts shall be repaired with a partial depth (spall repair) at the contractor's expense.

550 PLACING PORTLAND CEMENT CONCRETE: Placing of concrete in full 550 P01 depth repairs less than 100 feet in longitudinal length shall be performed the same day the concrete is removed or the repair shall be made safely traversable by an errant vehicle. On full depth repairs longer than 100 feet longitudinally, concrete shall be placed within 96 hours after the sawing for removal has begun. Placing, consolidating, finishing, and curing of the concrete shall be as provided in Section 550 except as follows: The faces of the old concrete around the section to be replaced shall be wetted with water before the new concrete is placed. The concrete shall be dumped or conveyed into the repair area in such a way that there will be no segregation of the aggregates and cement, and then spread into place, vibrated with a mechanical vibrator, and smoothed. Excessive vibrating shall be avoided. Full depth concrete patches that are more than 15 feet in longitudinal length shall be finished with a commercially manufactured screed capable of providing the finish and ride as specified in Section 550, with limited hand work required. Concrete shall be finished flush with the adjacent pavement surface and shall be straight edged to ensure a smooth riding surface, and shall be textured longitudinally by finishing with a carpet type or Astro Grass Drag, the

550/P01 (Cont)

intention being to recreate the texture of the adjacent surface. Repair areas over ten feet in length shall be checked by the contractor with 10 foot straight edge before the concrete has set, and spots that are 1/8 inch high, or low, as shown by the straight edge, shall be corrected. Repair areas that do not meet the surface tolerance shall be corrected as specified in Section 550.04 P.1.

550 SPALLS AT FULL DEPTH REPAIRS: If traffic is allowed on full 550 P02 depth repair locations after the repair edge sawcuts have been made, and before pavement is removed the contractor shall repair at his own expense any spalls occurring at the edge of the repair.

550 WORK SEQUENCE: The sequence of the work on this project shall be 550 P03 as follows:

1. Repair pavement, joints, and spalls. Subgrade repair, concrete pavement repair, joint repair (full depth) and spall repair (partial depth) work shall be performed simultaneously unless authorized by the engineer in writing.
2. Grinding 12' driving lane plus 3' of passing lane and 3' of outside shoulder adjacent to the driving lane.
3. Saw and seal random cracks and new and existing transverse joints. Saw and seal longitudinal centerline joint and 10' shoulder joint.

The contractor may submit alternate proposals for the work sequence; however, any alternate shall adequately address traffic safety.

550 GRINDING: In the proximity of the Mooreton weigh station the passing 550 P04 lane shall be ground instead of the driving lane. The exact location to be determined by the engineer.

550 PORTLAND CEMENT CONCRETE REPAIRS: The Portland Cement concrete for 550 P05 full-depth and spall repairs shall be a 6.0 bag mix with a maximum water content of 5.1 gal/bag of cement. The cement used for repair work shall be Type III cement that meets the requirements of AASHTO M85.

GENERAL NOTES

FED. AID REGION	STATE	FED. AID PROJ. NO.	SHEET NO.
8	N.D.	IM-8-029(003)022	6

550 CONCRETE PAVEMENT: The nine-inch PCC pavement at the subgrade repair
P06 area will be paid for as "9-Inch Concrete Pavement Repair (Full Depth -
Doweled)."

550 SMALL SPALLS: Areas shown as "small spalls not to be repaired"
P07 consist of a small spall of approximately 2" x 6" size located on a
joint. These small spalls shall be sealed with silicone along with the
joint and shall not be measured separately. All costs to seal these
small spalls shall be included in the unit price bid for "1 In
Transverse PCC Joint Clean and Sealing."

550 8 IN PCC PAVEMENT: Two 2' wide x 40' long x 8" deep concrete pads
P08 shall be placed at the Mooreton weigh station. The location shall be
determined by the engineer. All cost to sawcut and remove the existing
bituminous pavement, place the PCC pavement, and form and seal the
joints shall be included in the unit price bid for "8 In Non-Reinf.
Conc. Pavement - C1 AE."

704 TRAFFIC ROUTING DURING CONSTRUCTION: The contractor shall
034 provide one lane for traffic at all times except as authorized by the
engineer in writing. The contractor's traffic shall be in the same
direction as public traffic.

704 CONSTRUCTION TRAFFIC: The contractor's construction traffic
035 required for concrete pavement repair shall be limited to access at
interchanges only. Construction traffic shall not be permitted to park
or to operate in the median except as necessary for subgrade repair
areas, but only as directed by the engineer. Access from the one
roadway to the other roadway, through the median, shall not be
permitted.

704 PORTABLE PRECAST MEDIAN BARRIERS: The number of precast concrete
200 median barriers required on the project shall be 237 ten-foot units.
The barriers may be obtained from the Fargo District storage yard at
Casselton, transported to the work site, and assembled as required.
Upon completion of the project, the contractor shall return the
barriers to the Fargo District storage yard at Casselton. Any barriers
that become damaged during handling, transporting, placing, or during
use, shall be replaced at the contractor's expense. In lieu of using
state-furnished barriers, the contractor may furnish the required
barriers. The cost of obtaining transporting, installing, moving
maintaining, and returning the precast concrete median barriers shall
be incidental to the price bid for "Precast Concrete Median Barriers
(State Furnished)." These barriers have been provided to protect
traffic from subgrade repairs that are deeper than 2 feet.

704 BARRIER MARKERS: The contractor shall furnish, install and
210 remove barrier markers as specified on Standard D-748-9. The cost of
furnishing, installing, and removing barrier markers shall be included
in the price bid for "Precast Concrete Median Barriers (State
Furnished)."

704 MAINTENANCE AND PROTECTION OF TRAFFIC FOR CONCRETE PAVEMENT REPAIRS:
300 The various layouts for construction signing for various lane closures
show the required devices for each situation. The areas of lane
closure for concrete repair shall have tubular markers spaced at 100
feet on centerline roadway except in areas of full depth removal. In
these areas, vertical panels shall be spaced at 10 feet on centerline
roadway until the concrete has been replaced. A minimum of two
vertical panels shall be used at each full depth removal area. When
full depth removals are to be left open overnight, Type I Barricades
shall be placed in front of each open area or as directed by the
engineer. The barricades shall not encroach onto the traffic lane.
The quantities provide for 13 full depth repair locations and an
average of two vertical panels for each location.

The amount of each lane closure shall be limited to the actual daily
work area required plus curing repairs with a maximum of 5 miles. If
the contractor chooses to work in more than one area, the minimum
distance between the first closure and the advance signing for the
second closure shall be two miles. The quantities have been based on
two areas of lane closures of 5 miles each.

If the contractor is going to operate in a manner other than as herein
provided, a complete traffic control layout and program will have to be
provided to the North Dakota Department of Transportation for approval,
and that approval will have to be given before any work is performed.

704 Ramp traffic shall be maintained at all times during the pavement
302 removal and replacement.

704 TRAFFIC CONTROL PCC PAVEMENT GRINDING: The sign layout for One-Lane
P01 Closure Divided Highway Moving Operation, Standard D-704-32, will be
used for the PCC pavement grinding operation during the daytime.
Standard D-704-35 will be used for PCC grinding during nighttime
operation.

704 DELINEATOR DRUMS: 241 delineator drums are required for marking
P02 guardrail installation locations and are included in the traffic
control devices list.

708 EROSION CHECKS: Type C erosion checks have been provided for use at
P01 the following locations during construction:

Station 88+00	100 LF Rt & 100 LF Med
Station 121+00	80 LF Rt & 80 LF Med
Station 163+42	122 LF Rt
Station 218+00	80 LF Rt and 80 LF Med
Station 268+70	130 LF Rt
Station 691+64	130 LF Rt

ESTIMATED QUANTITIES

FHWA REGION	STATE	FED. AID PROJ. NO.	SHEET NO.
8	N.D.	IM-8-029(003)022	12

SPEC	CODE	ITEM DESCRIPTION	UNIT	MAINLINE	MOORETON WEIGH STATION	TOTAL
550	0424	DOWEL BARS	EA	1,500		1,500
550	0430	DOWEL BAR RETROFIT TYPE A	EA	4,665		4,665
550	0431	DOWEL BAR RETROFIT TYPE B	EA	4,665		4,665
550	0701	9IN JOINT REPAIR (FULL DEPTH - DOWELED)	SF	2,503		2,503
550	0711	9IN CONCRETE PWMT REPAIR (FULL DEPTH - DOWELED)	SY	8,191		8,191
550	0950	1/2IN TRANSVERSE PCC JOINT CLEAN AND SEALING	LF	52,289		52,289
550	0959	CONTRACTION JOINT SILICONE SEAL	LF	4,595		4,595
550	0965	LONGITUDINAL PCC JOINT CLEANING & SEALING	LF	98,768		98,768
550	0966	RANDOM PCC CRACK CLEANING AND SEALING	LF	3,463		3,463
550	1512	SPALL REPAIR (PARTIAL DEPTH)	SF	2,000		2,000
602	1130	CLASS AE-3 CONCRETE	CY		111	111
602	1210	BRIDGE END POST - MODIFICATION	EA	30		30
612	0115	REINFORCING STEEL - GRADE 60	LBS		12,686	12,686
616	5890	STRUCTURAL STEEL	L SUM		1	1
702	0100	MOBILIZATION	L SUM	1		1
704	0100	FLAGGING	M HR	3,000		3,000
704	1000	TRAFFIC CONTROL SIGNS	UNIT	3,733		3,733
704	1043	ATTENUATION DEVICE - TYPE B-85	EA	1		1
704	1050	TYPE I BARRICADE	EA	13		13
704	1052	TYPE III BARRICADE	EA	10		10
704	1060	DELINEATOR DRUMS	EA	323		323
704	1065	TRAFFIC CONES	EA	13		13
704	1067	TUBULAR MARKERS	EA	275		275
704	1081	VERTICAL PANELS (BACK TO BACK)	EA	26		26

A-7

BASIS OF ESTIMATE

FINA REGION	STATE	FED. AID PROJ. NO.	SHEET NO.
8	ND	IM-8-029(003)022	14

INTERSTATE--V. ROADWAY--BASIS OF ESTIMATE
PAVEMENT MARKING PAINTED LINE

Outside Edge Lines 4 Inch White - 5,280 LF/M	49,384 LF
Inside Edge Line - 4 Inch Yellow - 5,280 LF/M	49,384 LF
Lane Lines - 4 Inch White, 10' lines, 30' skip - 1,320 LF/M	12,346 LF

BASIS OF ESTIMATE

Hot Bituminous Pavement @ 2 TON/CY (Class 33)
 120-150 Asphalt Cement @ 6.0% of HBP Cl 33
 Emulsified Asphalt for Tack Coat @ 0.05 GAL/SY
 Water for Compaction 20 GAL/TON of Cl 3 and Cl 5 Aggregate
 Seeding All disturbed areas except roadbed

SPECIAL PROVISIONS

SP 135(92) Epoxy Coated Dowel Bar Retrofit
 SP 143(92) Grinding
 SP 144(92) Truck Weigh Scale

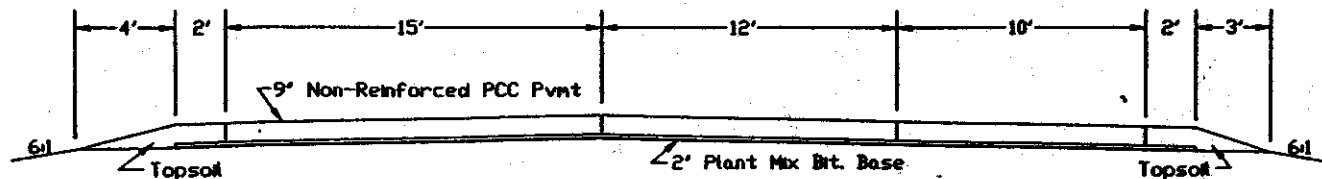

EXISTING TYPICAL SECTION

RETROFIT DOWEL BAR INSTALLATION

FHWA REGION	STATE	FED. AID PROJ. NO.	SHEET NO.
8	ND	IM-8-029(003)022	35

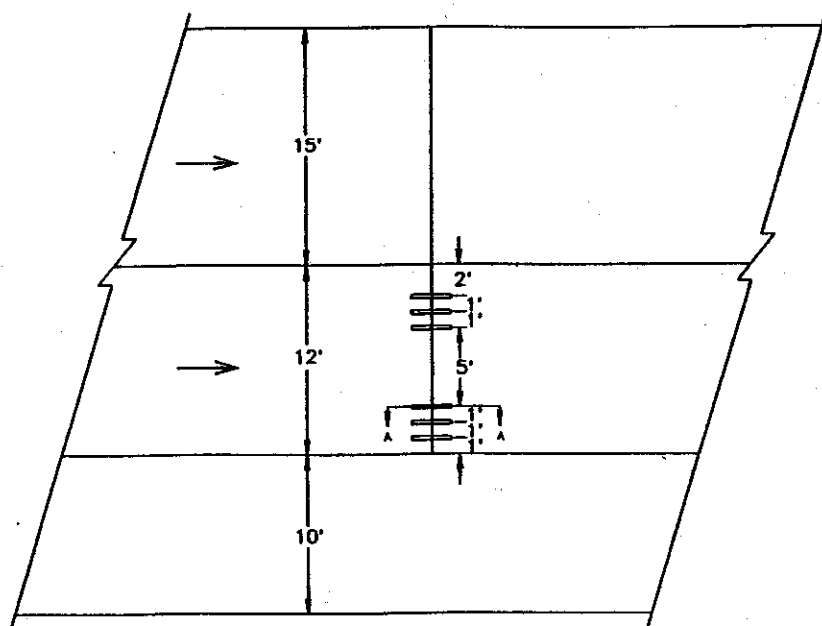

Retrofit Dowel Bar Spacing

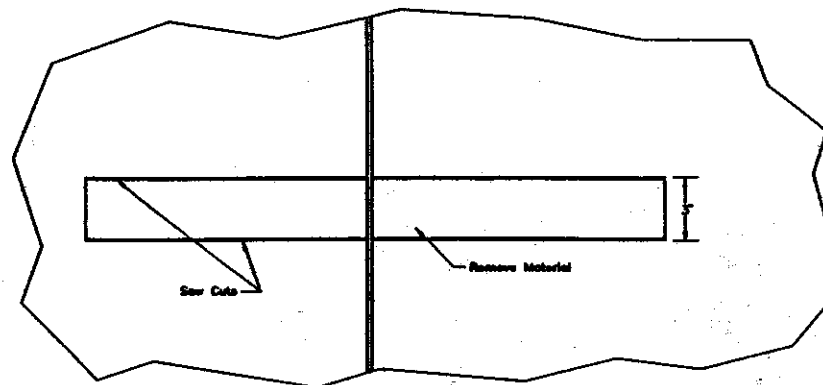

Plan View Dowel Bar Retrofit Slot Material Removal

QUANTITIES

Dowel Bar Retrofit—Type A, Each 4,665

Dowel Bar Retrofit—Type B, Each 4,665

Note: Dowel bar retrofit installation shall be 5 continuous miles, 2.5 miles Dowel Bar Retrofit—Type A and 2.5 miles Dowel Bar Retrofit—Type B.

The location of the dowel bar retrofit installation is to be determined by the Engineer.

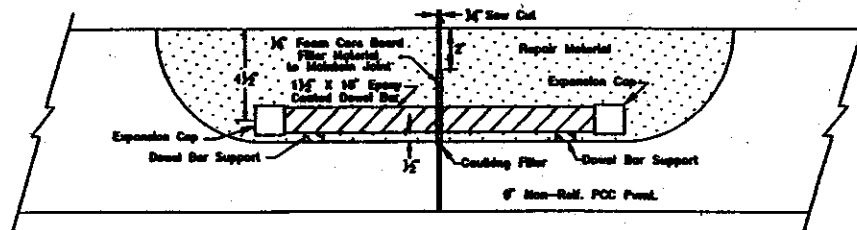
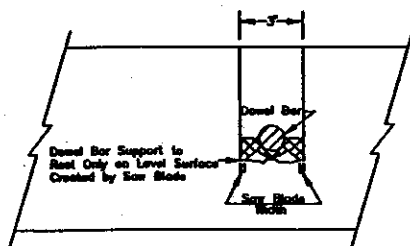

Section A-A, Dowel Bar Installation

DESIGN DATA				
Traffic	Average Daily			Est. Max. Hr.
Current 1995	Pass. 1460	Trucks 390	Total 1850	185
Forecast 2015	Pass. 2190	Trucks 590	Total 2780	280
Minimum Sight Dist. for:	Design Speed 80 MPH			
Stopping	1050'			
Full Control of Access				
No Point of Access Other Than at Interchange Ramps				

JOB# _____

FHWA REGION	STATE	PROJECT NO.	SHEET NO.
8	ND	IM-8-029(003)022	1

NORTH DAKOTA DEPARTMENT OF TRANSPORTATION

IN RICHLAND COUNTY

FEDERAL AID PROJECT NO. IM-8-029(003)022

Concrete Pavement Repair, Grinding
(South Bound Roadway)
Mooreton Weigh Station Parking Mill and Overlay

GOVERNING SPECIFICATIONS:

Standard Specifications adopted by the North Dakota Department of Transportation September 1992. Standard Drawings currently in effect and other Contract Provisions submitted herein.

LENGTH OF PROJECT

Miles Gross	Miles Net
21.484	21.258
0.226 Miles Deducted for Bridges	

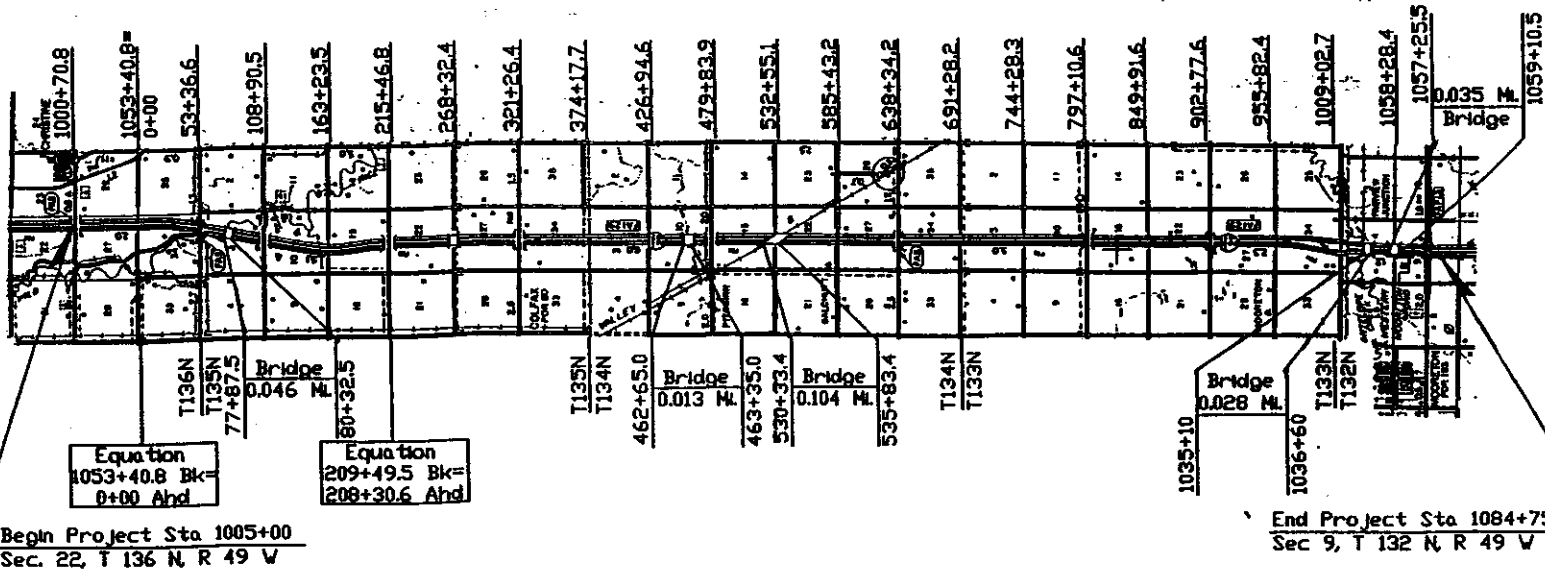
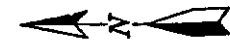

PAVING SECTION *Scott Woodman*
 URBAN SECTION _____
 TRAFFIC SECTION *George H. Smith*
 RURAL SECTION _____
 RECOMMEND APPROVAL *4-4-95*
 DESIGN ENGINEER *David A. [Signature]*

U.S. DEPARTMENT OF TRANSPORTATION
 FEDERAL HIGHWAY ADMINISTRATION
 APPROVED _____
 DIVISION ADMINISTRATOR DATE

APPROVED DATE *4-5-95*
Ray Zink
 DIRECTOR OF HIGHWAYS
 AND ENGINEERING
 NORTH DAKOTA
 DEPARTMENT OF TRANSPORTATION

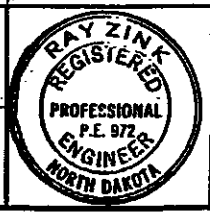

ESTIMATED QUANTITIES

FVA REGION	STATE	FED. AID PROJ. NO.	SHEET NO.
8	N.D.	IM-6-029(022)186	8

SPEC	CODE	ITEM DESCRIPTION	UNIT	WEST ROADWAY	TOTAL
103	0100	CONTRACT BOND	L SUM	1	1
202	0112	REMOVAL OF CONCRETE	SY	660	660
202	0110	SAW CONCRETE	LF	13,006	13,006
203	0208	GUARDRAIL EMBANKMENT - TYPE C	EA	10	10
410	0105	MILLING BITUMINOUS PAVEMENT	SY	2,760	2,760
550	0210	PCC PAVEMENT GRINDING	SY	99,504	99,504
550	0217	BRIDGE APPROACH SLAB - REMOVE AND REPLACE	SY	375	375
550	0240	DOWELED CONTRACTION JOINT ASSEMBLY	LF	168	168
550	0424	DOWEL BARS	EA	360	360
550	0430	DOWEL BAR RETROFIT TYPE A	EA	2,970	2,970
550	0431	DOWEL BAR RETROFIT TYPE B	EA	2,970	2,970
550	0711	9IN CONCRETE PVMT REPAIR (FULL DEPTH - DOWELED)	SY	650	650
550	0959	CONTRACTION JOINT SILICONE SEAL	LF	12,596	12,596
602	1200	JERSEY BARRIER - FORMED OR SLIPFORMED	LF	104	104
602	1210	BRIDGE END POST - MODIFICATION	EA	4	4
702	0100	MOBILIZATION	L SUM	1	1
704	0100	FLAGGING	M HR	400	400
704	1000	TRAFFIC CONTROL SIGNS	UNIT	1,485	1,485
704	1050	TYPE I BARRICADE	EA	15	15
704	1052	TYPE III BARRICADE	EA	10	10
704	1060	DELINEATOR DRUMS	EA	191	191
704	1065	TRAFFIC CONES	EA	12	12
704	1067	TUBULAR MARKERS	EA	274	274
704	1081	VERTICAL PANELS (BACK TO BACK)	EA	56	56

A-11

TYPICAL SECTION
(Removal & PCC Pmnt Sections)

FYMA REGION	STATE	FED. AID PROJ. NO.	SHEET NO.
8	N.D.	IM-6-029(022)186	12

Sta 1088+00 to Sta 1088+45	Sta 1123+10 to Sta 1123+25
Sta 1089+60 to Sta 1089+75	Sta 1234+15 to Sta 1234+45
Sta 1092+60 to Sta 1093+20	Sta 1116+40 to Sta 1116+70
Sta 1108+60 to Sta 1108+90	Sta 1277+00 to Sta 1277+16

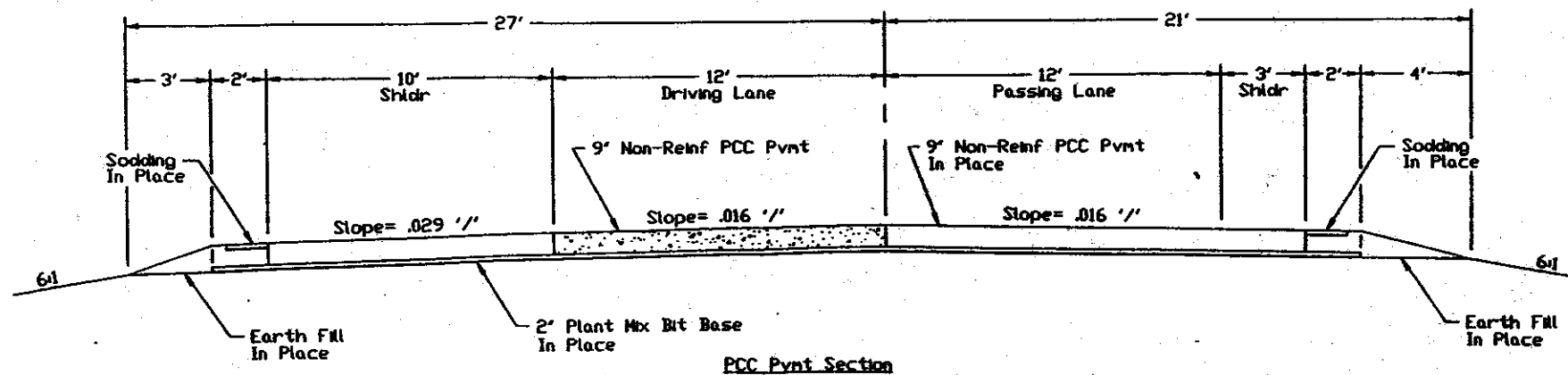
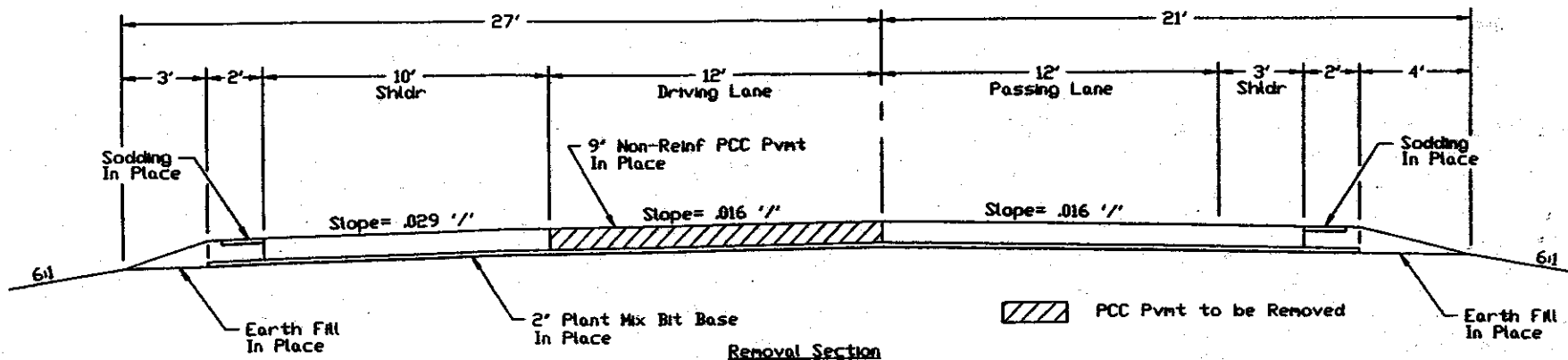

A-12

TYPICAL SECTION
(Grinding)

FYMA REGION	STATE	FED. AID PROJ. NO.	SHEET NO.
8	N.D.	IN-6-029(022)186	15

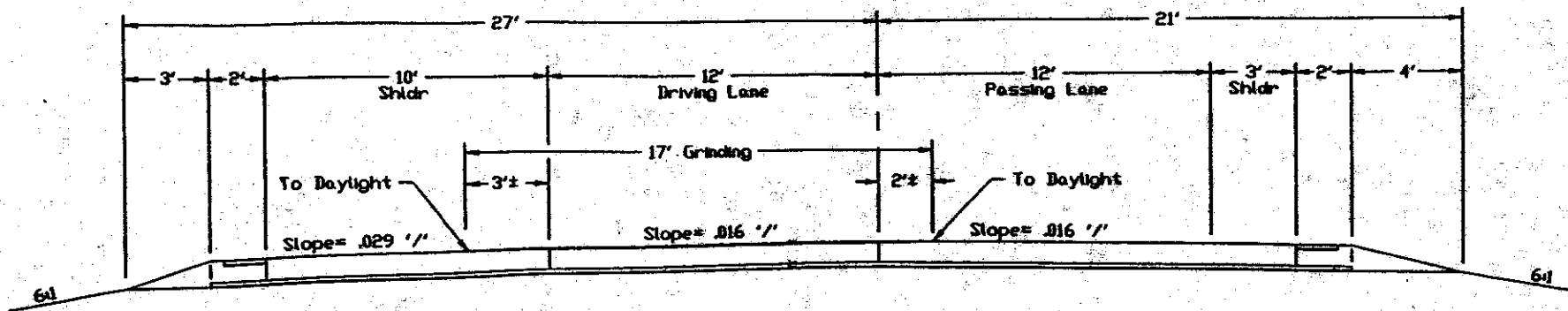

A-13

RETROFIT DOWEL BAR INSTALLATION

FEMA REGION	STATE	FED. AID PROJ. NO.	SHEET NO.
8	ND	IM-6-029(022)186	19

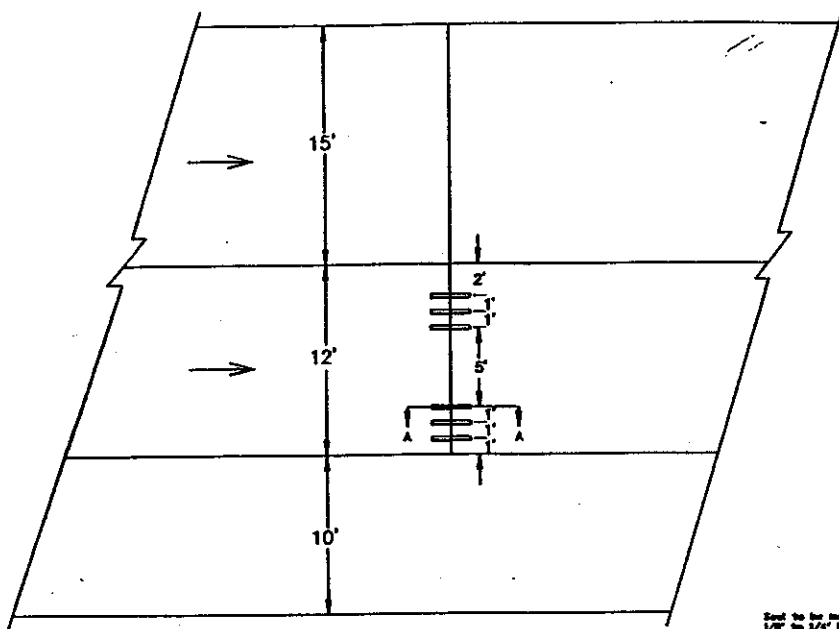

Retrofit Dowel Bar Spacing

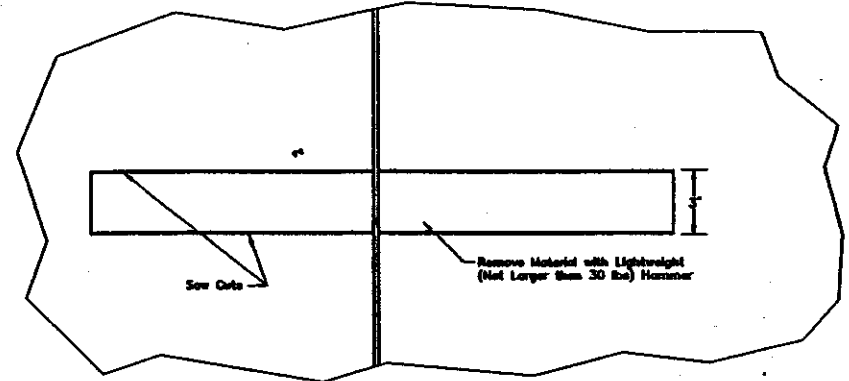

Plan View Dowel Bar Retrofit Slot Material Removal

QUANTITIES

- Dowel Bar Retrofit—Type A, Each 2,970
- Dowel Bar Retrofit—Type B, Each 2,970

Note: Dowel bar retrofit installation shall be 3 continuous miles Driving Lane Only, 1.5 miles Dowel Bar Retrofit—Type A and 1.5 miles Dowel Bar Retrofit—Type B. The location of the dowel bar retrofit installation is to be determined by the Engineer. The 12' Driving lane where the Dowel Bar Retrofit is placed shall be sawed and sealed according to the Dowel Bar Retrofit Joint Detail. All cost to saw and seal the Dowel Bar Retrofit Joints shall be paid for at the unit price bid for "Contraction Joint Silicone Seal."

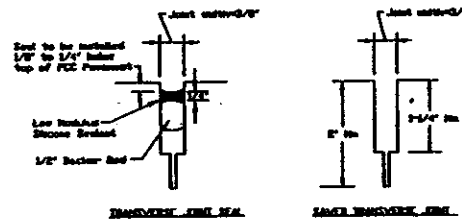

Dowel Bar Retrofit Silicone Joint Detail

SPECIAL PROVISION

SP 141(92) Epoxy Coated Dowel Bar Retrofit

See Dowel Bar Retrofit Silicone Joint Detail

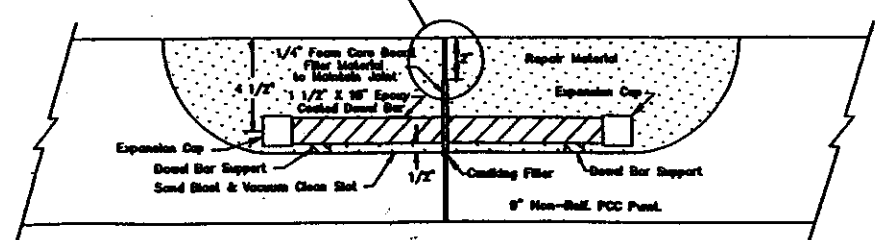
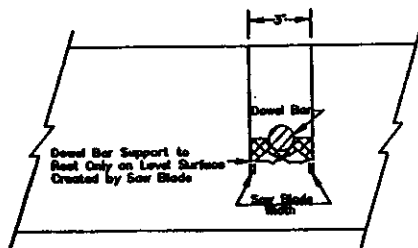

Section A-A, Dowel Bar Installation

A-14

Appendix B

4-10-95

NORTH DAKOTA DEPARTMENT OF TRANSPORTATION

SPECIAL PROVISION

DOWEL BAR RETROFIT

PROJECT IM-6-029(022)186

June 16, 1995

DESCRIPTION

This work consists of retrofitting epoxy-coated dowel bars into existing concrete pavement.

MATERIALS

1. Curing Compound. The curing compound shall be a liquid membrane-forming compound that conforms to the requirements of AASHTO M-148 (ASTM C 309) Type 1-D or 2, Class A or B.
2. Dowel Bars. The Dowel bars shall be plain, round bars fabricated from steel meeting AASHTO M-31, M-42, or M-53. Dowel bars shall be cut to the required length and cleaned to remove all cutting burrs, loose mill scale, rust, grease, and oil. The bars may be sheared providing the deformation of the bars from true round shape does not exceed 0.04 inch in diameter or thickness, and shall not extend more than 0.04 inch from the sheared end.

Dowel bars shall be epoxy-coated 100% on all surfaces. The epoxy coating shall be in accordance with AASHTO M-284. The dowel bars shall also be shop coated with a bond breaking release agent. The bond breaking release agent shall be a black, non-diluted, Tectyl 164 as manufactured by Valvoline Oil Co. The dowel bars shall be installed and covered with patch material within 6 months of the delivery date.

The dowel bars shall have tight fitting end caps made of nonmetallic materials that allow for 1/4 inch movement of the bar at each end. The Contractor shall submit sample end caps to the Engineer prior to use.

3. Caulk. The caulk for sealing the existing transverse joint crack at the bottom and sides of the slot shall be any commercial caulk designed as a concrete sealant that is compatible with the patch material being used.
4. Foam Core Board. The foam core board shall be 1/4 inch thick, constructed of closed cell foam, and be faced with poster board material on each side.
5. Patching Material. Two types of patch material will be used on this project. One-half of the project will be completed using a

patch mix made from local materials and the other half will be completed using a commercial patch mix.

- a. "Concrete Patch Mix Type A" shall be a mix prepared using the following mix design:

Cement	850 lbs
Water	295 lbs
Sand	1318 lbs
Course Aggr.	1341 lbs.

The cement used shall be a Type I, IA, II, or IIA cement meeting the requirements of Section 804.01.

Air-Entraining Admixture shall meet the requirements of Section 808.01. The air content of the mix shall be maintained at 5.5 percent, plus or minus 1.5 percent.

Fine aggregates shall meet the requirements of Section 816.01.

Course aggregate shall meet the requirements of Section 816.02. The gradation for the course aggregate shall be:

<u>Sieve</u>	<u>% Passing</u>
3/8"	100
#4	70-95

- b. "Concrete Patch Mix Type B" shall be Patchroc 10-60, Five Star Highway Patch, Burke 928 Fast Patch or an approved equal.
6. Chairs. The chairs for supporting and holding the dowel bars in place shall be completely epoxy coated according to Section 836.02B, or made of nonmetallic material.

CONSTRUCTION REQUIREMENTS

The Contractor shall install the dowel bars in the existing concrete pavement as shown in the Plans and according to the following specifications:

1. Slots shall be saw cut in the pavement to the depth required to place the center of the dowel at mid-depth in the concrete slab. Multiple saw cuts parallel to the centerline may be required to properly remove material from the slot.
2. Jack hammers used to remove the concrete shall not be larger than the 30 pound class.
3. All exposed surfaces and cracks in the slot shall be sand blasted and cleaned of saw slurry and loose material before installing the dowel. All loose material will be disposed of by the Contractor off of the highway right-of-way.

4. Dowel bars shall be placed in a chair that will provide a minimum of 1/2 inch clearance between the bottom of the dowel and the bottom of the slot. The dowel bar shall be placed to the depth shown in the plans, parallel to the centerline, and parallel to pavement surface of the lower panel at the transverse joint, all to a tolerance of 1/4 inch. The chair design shall hold the dowel bar securely in place during the placement of the patch mix.
5. The contractor shall caulk the existing transverse joint crack at the bottom and sides of the slot as shown in the Plans. The transverse joint crack shall be caulked to provide a tight fit for the foam core board at the transverse joint and to prevent any of the patch mix from entering the crack at the bottom or the sides of the slot.
6. The dowel bar shall be placed through the foam core board at the specified location. The dowel bar shall be placed so a minimum of 7.0 inches is placed on either side of the transverse joint. The foam core board shall be capable of remaining in a vertical position and tight to all edges during the placement of the patch mix. If for any reason the foam core board shifts during the placement of the patch mix, the work shall be rejected and replaced at the Contractor's expense.
7. The existing concrete surfaces inside the slotted area shall be moistened with a hand sprayer immediately prior to placing the patch mix.
8. The patch mix shall be placed into the slot and vibrated with a small hand held vibrator to insure that the patch mix completely surrounds the dowel bar.
9. The surface of the filled area shall be cured using a curing compound that meets the requirements of AASHTO M-148.
10. The transverse joint shall be maintained by sawing the joint through the patched area within 24 hours after placement of the patch mix. The joint shall be sawed and sealed as shown in the plans

METHOD OF MEASUREMENT

Dowel Bars will be measured by each dowel bar installed and accepted by the Engineer.

BASIS OF PAYMENT

Payment for "Dowel Bar Retrofit - Type A" shall be full compensation for all labor, equipment, and materials necessary to complete the work using Type A patch mix.

Payment for "Dowel Bar Retrofit - Type B" shall be full compensation for all labor, equipment, and materials necessary to complete the work using Type B patch mix.

Payment will be made at Contract Unit Prices for the following:

<u>Pay Item</u>	<u>Pay Unit</u>
Dowel Bar Retrofit - Type A	Each
Dowel Bar Retrofit - Type B	Each

NORTH DAKOTA DEPARTMENT OF TRANSPORTATION

SPECIAL PROVISION

DOWEL BAR RETROFIT

PROJECT IM-8-029(003)022

May 19, 1995

DESCRIPTION

This work consists of retrofitting epoxy-coated dowel bars into existing concrete pavement.

MATERIALS

1. Curing Compound. The curing compound shall be a liquid membrane-forming compound that conforms to the requirements of AASHTO M-148 (ASTM C 309) Type 1-D or 2, Class A or B.
2. Dowel Bars. The Dowel bars shall be plain, round bars fabricated from steel meeting AASHTO M-31, M-42, or M-53. Dowel bars shall be cut to the required length and cleaned to remove all cutting burrs, loose mill scale, rust, grease, and oil. The bars may be sheared providing the deformation of the bars from true round shape does not exceed 0.04 inch in diameter or thickness, and shall not extend more than 0.04 inch from the sheared end.

Dowel bars shall be epoxy-coated 100% on all surfaces. The epoxy coating shall be in accordance with AASHTO M-284. The dowel bars shall also be shop coated with a bond breaking release agent. The bond breaking release agent shall be a black, non-diluted, Tectyl 164 as manufactured by Valvoline Oil Co. The dowel bars shall be installed and covered with patch material within 6 months of the delivery date.

The dowel bars shall have tight fitting end caps made of nonmetallic materials that allow for 1/4 inch movement of the bar at each end. The Contractor shall submit sample end caps to the Engineer prior to use.

3. Caulk. The caulk for sealing the existing transverse joint crack at the bottom and sides of the slot shall be any commercial caulk designed as a concrete sealant that is compatible with the patch material being used.
4. Foam Core Board. The foam core board shall be 1/4 inch thick, constructed of closed cell foam, and be faced with poster board material on each side.
5. Patching Material. Two types of patch material will be used on this project. One-half of the project will be completed using a

patch mix made from local materials and the other half will be completed using a commercial patch mix.

- a. "Concrete Patch Mix Type A" shall be a mix prepared using the following mix design:

Cement	850 lbs
Water	295 lbs
Sand	1318 lbs
Course Aggr.	1341 lbs.

The cement used shall be a Type I, IA, II, or IIA cement meeting the requirements of Section 804.01.

Air-Entraining Admixture shall meet the requirements of Section 808.01. The air content of the mix shall be maintained at 5.5 percent, plus or minus 1.5 percent.

Fine aggregates shall meet the requirements of Section 816.01.

Course aggregate shall meet the requirements of Section 816.02. The gradation for the course aggregate shall be:

<u>Sieve</u>	<u>% Passing</u>
3/8"	100
#4	70-95

- b. "Concrete Patch Mix Type B" shall be Patchroc 10-60, Five Star Highway Patch, Burke 928 Fast Patch or an approved equal.

6. Chairs. The chairs for supporting and holding the dowel bars in place shall be completely epoxy coated according to Section 836.02B, or made of nonmetallic material.

CONSTRUCTION REQUIREMENTS

The Contractor shall install the dowel bars in the existing concrete pavement as shown in the Plans and according to the following specifications:

1. Slots shall be saw cut in the pavement to the depth required to place the center of the dowel at mid-depth in the concrete slab. Multiple saw cuts parallel to the centerline may be required to properly remove material from the slot.
2. Jack hammers used to remove the concrete shall not be larger than the 30 pound class.
3. All exposed surfaces and cracks in the slot shall be sand blasted and cleaned of saw slurry and loose material before installing the dowel. All loose material will be disposed of by the Contractor off of the highway right-of-way.

4. Dowel bars shall be placed in a chair that will provide a minimum of 1/2 inch clearance between the bottom of the dowel and the bottom of the slot. The dowel bar shall be placed to the depth shown in the plans, parallel to the centerline, and parallel to pavement surface of the lower panel at the transverse joint, all to a tolerance of 1/4 inch. The chair design shall hold the dowel bar securely in place during the placement of the patch mix.
5. The contractor shall caulk the existing transverse joint crack at the bottom and sides of the slot as shown in the Plans. The transverse joint crack shall be caulked to provide a tight fit for the foam core board at the transverse joint and to prevent any of the patch mix from entering the crack at the bottom or the sides of the slot.
6. The dowel bar shall be placed through the foam core board at the specified location. The dowel bar shall be placed so a minimum of 7.0 inches is placed on either side of the transverse joint. The foam core board shall be capable of remaining in a vertical position and tight to all edges during the placement of the patch mix. If for any reason the foam core board shifts during the placement of the patch mix, the work shall be rejected and replaced at the Contractor's expense.
7. The existing concrete surfaces inside the slotted area shall be moistened with a hand sprayer immediately prior to placing the patch mix.
8. The patch mix shall be placed into the slot and vibrated with a small hand held vibrator to insure that the patch mix completely surrounds the dowel bar.
9. The surface of the filled area shall be cured using a curing compound that meets the requirements of AASHTO M-148.
10. The transverse joint shall be maintained by sawing the joint through the patched area within 24 hours after placement of the patch mix. The joint shall be sawed and sealed as shown in the plans

METHOD OF MEASUREMENT

Dowel Bars will be measured by each dowel bar installed and accepted by the Engineer.

BASIS OF PAYMENT

Payment for "Dowel Bar Retrofit - Type A" shall be full compensation for all labor, equipment, and materials necessary to complete the work using Type A patch mix.

Payment for "Dowel Bar Retrofit - Type B" shall be full compensation for all labor, equipment, and materials necessary to complete the work using Type B patch mix.

Payment will be made at Contract Unit Prices for the following:

<u>Pay Item</u>	<u>Pay Unit</u>
Dowel Bar Retrofit - Type A	Each
Dowel Bar Retrofit - Type B	Each

Appendix C

INTERSTATE 29 - LOAD TRANSFER

08/28/01

MILE AVE
188 40.6%
189 41.2%

PROJ AVE 40.9%
STD DEV 15.7%

Chainage	Def #1	Def #2	%	Chainage	Def #1	Def #2	%
188.4267	33.90	24.18	71.32%	189.4255	43.952587	24.6144046	56.00%
188.4284	39.66	20.44	51.53%	189.4271	42.1454533	22.7674696	54.02%
188.4299	49.77	14.83	29.81%	189.4286	48.891417	15.9146922	32.55%
188.4317	40.56	23.36	57.60%	189.4304	52.9855127	14.3955008	27.17%
188.4333	40.38	24.14	59.78%	189.4321	34.7946318	13.0217385	37.42%
188.4352	45.71	16.41	35.91%	189.4335	49.5618158	12.3504515	24.92%
188.4368	40.91	12.34	30.16%	189.4353	59.6902275	18.220165	30.52%
188.4382	36.66	19.16	52.27%	189.4370	56.6505357	17.0034935	30.01%
188.4399	42.73	13.66	31.98%	189.4384	60.959401	18.1385956	29.76%
188.4415	47.85	15.04	31.43%	189.4398	43.1852888	22.660332	52.47%
188.4433	46.18	16.10	34.87%	189.4413	51.1528808	15.7411094	30.77%
188.4448	39.99	24.17	60.44%	189.4431	56.0230769	19.4229424	34.67%
188.4466	38.49	20.41	53.03%	189.4446	46.3723839	13.9146933	30.01%
188.4482	49.77	14.56	29.26%	189.4460	31.878163	30.8377283	96.74%
188.4498	44.11	15.47	35.08%	189.4476	50.2544844	15.1000327	30.05%
188.4512	40.13	20.62	51.37%	189.4494	49.6926809	18.7425728	37.72%
188.4530	47.48	16.41	34.57%	189.4510	46.3796331	13.9785856	30.14%
188.4543	41.24	23.82	57.75%	189.4525	47.9436654	13.1725712	27.48%
188.4561	42.57	14.60	34.29%	189.4540	51.6408454	14.5556423	28.19%
188.4577	47.04	13.58	28.86%	189.4555	51.3465517	11.6879482	22.76%
188.4593	33.56	22.21	66.18%	189.4571	36.5654733	30.9453276	84.63%
188.4611	38.52	17.13	44.46%	189.4588	54.872542	18.6859244	34.05%
188.4627	41.33	17.57	42.52%	189.4605	52.8041524	15.1183768	28.63%
188.4642	32.19	25.09	77.93%	189.4619	53.4340719	15.9413041	29.83%
188.4653	42.74	12.60	29.49%	189.4635	54.6840641	16.1473611	29.53%
188.4671	37.19	15.34	41.23%	189.4653	54.5375934	15.7847848	28.94%
188.4686	38.18	11.59	30.36%	189.4668	56.6746346	16.6758554	29.42%
188.4705	38.15	14.18	37.18%	189.4684	47.318501	16.047029	33.91%
188.4720	42.46	13.16	30.98%	189.4699	48.6716102	16.6506879	34.21%
188.4734	43.73	13.30	30.41%	189.4716	50.3202381	18.7459972	37.25%
188.4748	42.56	13.57	31.89%	189.4732	51.1905916	19.5792798	38.25%
188.4762	37.61	15.80	42.01%	189.4750	59.098328	18.411988	31.15%
188.4778	36.01	14.60	40.54%	189.4766	56.510338	16.6646004	29.49%
188.4795	35.07	19.45	55.47%	189.4783	47.7593539	22.66229	47.45%
188.4813	35.08	22.72	64.76%	189.4802	55.7184178	16.3101251	29.27%
188.4826	43.24	10.98	25.40%	189.4817	40.4185778	36.9770364	91.49%
188.4842	44.33	20.34	45.88%	189.4831	54.2561165	22.0668014	40.67%
188.4861	40.21	19.00	47.25%	189.4844	59.3276218	17.5143054	29.52%
188.4875	35.07	21.36	60.91%	189.4858	56.1758582	23.8235488	42.41%
188.4890	37.97	18.26	48.08%	189.4874	42.3272392	39.4475006	93.20%
188.4907	50.46	14.14	28.02%	189.4890	50.6163939	39.3269122	77.70%
188.4924	41.84	16.39	39.17%	189.4906	58.276175	32.953646	56.55%
188.4939	41.31	17.84	43.19%	189.4924	57.7197703	17.2615292	29.91%
188.4952	44.56	12.90	28.94%	189.4938	59.9667959	18.1197538	30.22%
188.4970	44.32	12.07	27.25%	189.4952	65.8826035	26.5536378	40.30%
188.4985	41.09	14.29	34.77%	189.4970	41.0386337	27.9492576	68.10%
188.4999	38.77	15.13	39.01%	189.4985	58.7089075	17.6130551	30.00%
188.5014	42.45	12.22	28.79%	189.4999	52.3637869	17.682413	33.77%
188.5032	41.86	14.32	34.20%	189.5014	49.3299896	20.1283635	40.80%
188.5048	40.16	13.06	32.52%	189.5031	51.8600963	16.6335201	32.07%
188.5064	39.50	12.69	32.14%	189.5048	48.1349755	20.8125853	43.24%
188.5081	37.60	10.94	29.11%	189.5064	53.5106862	15.9229477	29.76%
188.5098	38.00	10.43	27.45%	189.5079	49.025761	14.0133152	28.58%
188.5112	39.65	12.99	32.77%	189.5096	37.753877	33.3147721	88.24%
188.5126	37.85	18.10	47.82%	189.5112	58.8120849	18.7717223	31.92%
188.5143	41.54	11.08	26.67%	189.5126	53.576631	22.3665972	41.75%
188.5160	43.12	13.00	30.16%	189.5141	51.1994629	24.9120121	48.66%
188.5178	38.34	16.83	43.90%	189.5157	49.837043	25.0855143	50.34%
188.5193	40.47	12.83	31.70%	189.5173	56.8149844	19.5765925	34.46%
188.5207	39.32	14.03	35.69%	189.5190	54.8187728	19.5234357	35.61%
				189.5203	50.1170209	24.063615	48.01%
				189.5217	62.0650545	17.636194	28.42%
				189.5235	48.0646713	33.7357758	70.19%
				189.5252	58.9389841	21.7155595	36.84%
				189.5268	64.5336187	21.9999723	34.09%

INTERSTATE 29

	08/30/01		
MILE	AVE	PROJ AVE	94.2
41	93.3	STD DEV	5.6
42	95.0		

Chainage	#1 DEF	#2 DEF	%	Chainage	#1 DEF	#2 DEF	%
41.4267	32.70	29.93	91.5	42.0469	45.06	29.60	65.7
41.4284	32.10	29.28	91.2	42.4261	39.72	38.53	97.0
41.4297	38.56	24.84	64.4	42.4278	40.17	38.87	96.8
41.4314	38.03	24.16	63.5	42.4296	40.66	39.21	96.4
41.4334	31.04	29.53	95.1	42.4312	40.62	39.50	97.2
41.4349	33.39	31.71	95.0	42.4328	39.37	37.71	95.8
41.4364	35.78	31.34	87.6	42.4344	37.22	36.18	97.2
41.4382	36.76	33.38	90.8	42.4362	40.81	38.38	94.0
41.4400	36.94	36.11	97.7	42.4378	40.42	38.98	96.4
41.4417	37.41	36.72	98.1	42.4394	40.05	38.38	95.8
41.4431	39.88	37.60	94.3	42.4410	43.86	42.13	96.1
41.4447	37.66	36.56	97.1	42.4428	42.78	41.33	96.6
41.4465	39.83	38.77	97.4	42.4445	38.91	37.56	96.5
41.4480	35.45	34.79	98.1	42.4460	39.99	38.51	96.3
41.4497	40.27	36.80	91.4	42.4477	43.67	39.92	91.4
41.4515	37.03	35.63	96.2	42.4497	43.75	42.24	96.6
41.4531	35.80	34.40	96.1	42.4513	44.23	41.97	94.9
41.4546	34.32	32.63	95.1	42.4527	44.30	42.69	96.4
41.4564	37.34	35.53	95.1	42.4543	45.21	43.36	95.9
41.4583	35.11	34.03	96.9	42.4561	44.07	41.92	95.1
41.4599	35.87	34.27	95.5	42.4578	41.37	39.86	96.4
41.4614	34.02	31.56	92.8	42.4593	39.81	38.82	97.5
41.4630	32.76	31.16	95.1	42.4609	41.27	39.86	96.6
41.4646	32.40	30.94	95.5	42.4627	47.76	45.52	95.3
41.4663	32.94	31.50	95.6	42.4644	42.64	41.13	96.5
41.4677	31.66	29.65	93.7	42.4659	41.64	40.27	96.7
41.4694	32.98	31.00	94.0	42.4675	39.42	38.55	97.8
41.4713	30.97	29.65	95.8	42.4693	42.14	40.95	97.2
41.4729	31.68	30.03	94.8	42.4710	41.19	33.84	82.1
41.4742	32.33	30.56	94.5	42.4726	39.63	38.33	96.7
41.4779	33.59	31.96	95.1	42.4742	46.25	43.86	94.8
41.4795	31.64	29.60	93.6	42.4760	41.45	38.84	93.7
41.4807	31.72	29.28	92.3	42.4777	43.34	41.31	95.3
41.4824	32.35	30.63	94.7	42.4791	48.54	45.19	93.1
41.4847	33.68	32.48	96.4	42.4805	41.90	40.45	96.5
41.4865	31.91	31.30	98.1	42.4823	38.55	37.72	97.9
41.4880	37.19	35.52	95.5	42.4839	36.67	35.35	96.4
41.4891	32.87	31.32	95.3	42.4854	35.42	34.42	97.2
41.4911	35.05	32.71	93.3	42.4872	37.98	35.76	94.1
41.4925	31.76	31.10	97.9	42.4890	38.53	37.11	96.3
41.4941	32.13	30.68	95.5	42.4910	36.34	34.98	96.3
41.4961	36.71	31.94	87.0	42.4918	34.59	33.85	97.9
41.4977	39.85	30.55	76.7	42.4935	37.01	34.90	94.3
41.4990	34.22	32.77	95.7	42.4954	38.28	36.16	94.5
41.5007	34.34	33.39	97.2	42.4973	35.69	33.59	94.1
41.5026	33.69	32.92	97.7	42.4987	37.23	35.20	94.5
41.5040	36.76	35.36	96.2	42.5004	37.42	36.33	97.1
41.5054	32.88	31.92	97.1	42.5022	38.23	36.96	96.7
41.5069	32.81	31.97	97.4	42.5038	38.43	36.83	95.8
41.5085	41.82	36.08	86.3	42.5054	37.82	36.50	96.5
41.5101	39.78	36.86	92.6	42.5071	38.40	36.52	95.1
41.5113	37.56	34.67	92.3	42.5092	35.36	34.19	96.7
41.5132	35.94	34.05	94.7	42.5109	34.96	33.57	96.0
41.5149	38.62	37.21	96.3	42.5125	37.82	36.16	95.6
41.5165	40.27	37.57	93.3	42.5141	38.90	37.23	95.7
41.5180	39.98	38.47	96.2	42.5161	36.78	35.69	97.0
41.5198	38.02	37.11	97.6	42.5177	34.59	33.23	96.1
41.5215	39.36	37.89	96.3	42.5191	38.02	34.67	91.2
41.5230	41.23	37.59	91.2	42.5207	40.52	38.17	94.2
41.5247	39.70	36.65	92.3	42.5228	40.69	36.96	90.8
41.5263	41.23	35.59	86.3	42.5244	41.23	39.08	94.8
				42.5256	42.21	39.46	93.5
				42.5274	39.06	37.71	96.5

Grand Forks Project - IM-6-029(022)186

Typical Joints where Patchroc 10-60 was used as the patch mix material

There are two columns for 1995. The first column shows load transfer percentages before dowels were installed. The second column shows load transfer percentages just after installation.

TESTLOC	1995	1995	1996	1997	1998	1999	2000	2001
189+4904	20.08	79.78	81.6	84.6	80.7	N/A	70.8	56.6
189+4888	23.49	86.85	73.8	45.5	43.7	N/A	86.7	77.7
189+4872	22.63	86.29	77.0	82.2	90.4	N/A	90.3	93.2
189+4856	25.62	83.66	81.3	81.4	83.9	N/A	51.7	42.4
189+4841	28.42	77.77	74.9	59.1	37.5	N/A	36.5	29.5
189+4827	25.91	78.82	56.0	57.6	55.0	N/A	48.3	40.7
189+4814	43.13	85.81	71.1	82.5	89.5	N/A	86.9	91.5
189+4798	23.26	83.37	66.7	60.5	55.5	N/A	28.5	29.3
189+4783	23.98	71.58	75.3	80.0	82.9	N/A	67.9	47.5
189+4765	25.44	76.66	68.6	67.3	51.2	N/A	28.0	29.5
189+4750	26.20	75.72	58.9	46.3	38.4	N/A	24.2	31.2
189+4731	26.17	82.51	70.0	67.0	77.8	N/A	51.2	38.3
189+4715	22.38	68.13	72.5	69.4	66.7	N/A	46.2	37.3
189+4699	23.40	72.50	63.1	50.3	47.1	N/A	37.8	34.2
189+4683	25.17	68.64	64.1	56.8	62.3	N/A	41.1	33.9
189+4667	25.11	71.56	66.5	51.6	30.5	N/A	27.1	29.42
189+4650	26.28	64.89	62.9	58.9	39.3	N/A	25.4	28.94
189+4632	23.25	81.95	61.8	53.9	37.4	N/A	30.7	29.5
189+4616	22.59	79.57	77.9	58.4	42.3	N/A	27.6	29.8
189+4602	22.97	87.36	81.5	79.7	60.4	N/A	33.1	28.6
189+4586	23.43	84.91	79.4	75.3	62.5	N/A	30.7	34.1
189+4568	30.81	77.98	77.9	89.6	86.8	N/A	73.3	84.6
189+4554	31.99	53.36	59.5	62.2	38.6	N/A	29.6	22.76
189+4540	26.33	51.63	42.2	33.1	23.9	N/A	30.8	28.2
189+4524	29.95	77.89	56.6	44.2	42.5	N/A	35.0	27.48
189+4509	36.63	79.65	66.8	75.0	61.8	N/A	48.7	30.1
Average	26.33	76.49	68.76	64.31	57.26		45.70	41.78
Increase(%)		50.16	-7.74	-4.45	-7.05		-11.56	-3.92

Grand Forks-Patchroc 10-60 Patch Mix

% Load Transfer

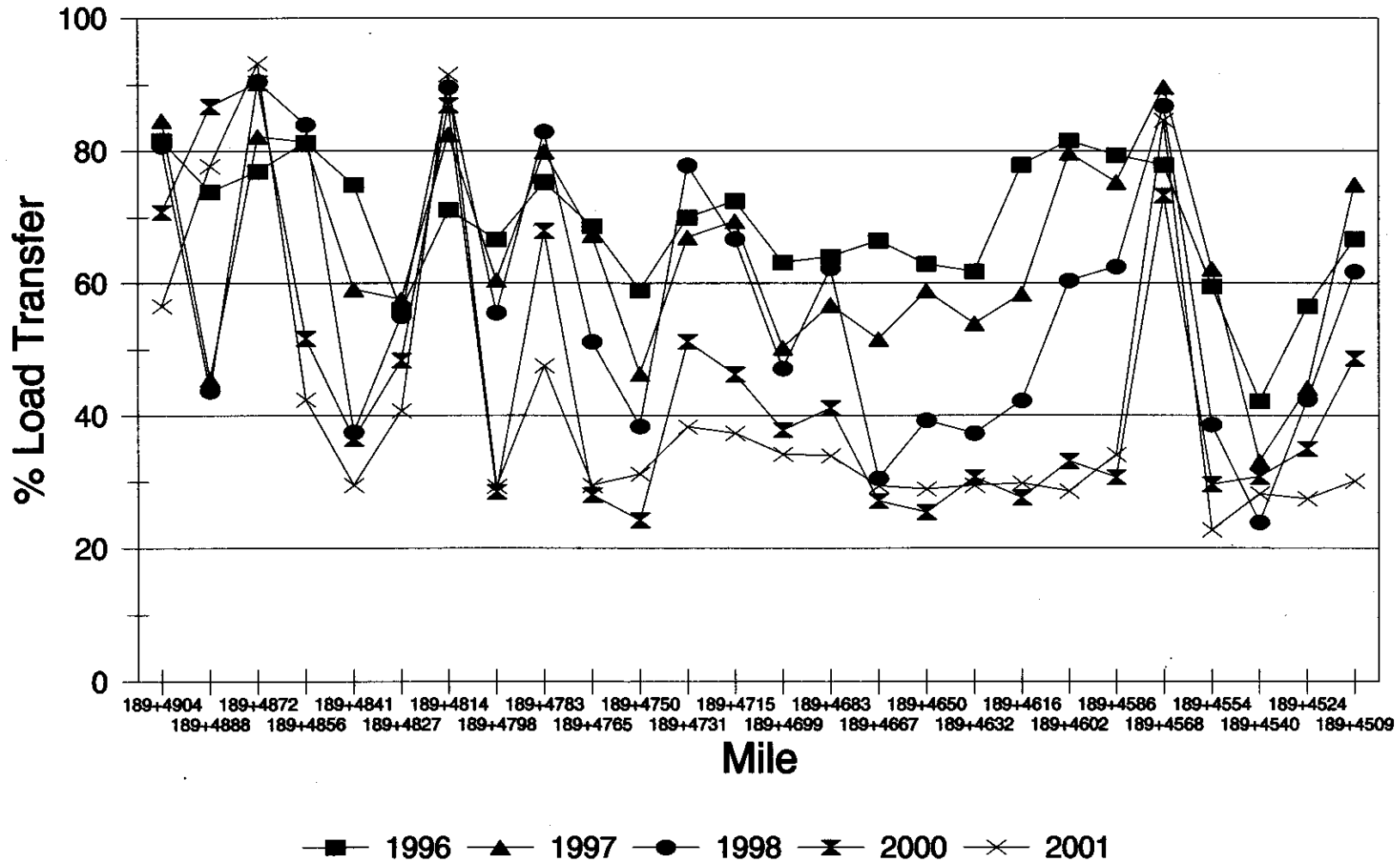

9-0

Grand Forks Project - IM-6-029(022)186

Typical Joints where Minnesota specified 3U18 was used as the patch mix material

The percentages under 1995 are those registered before the dowels were installed

TESTLOC	1995	1996	1997	1998	1999	2000	2001
188+4906	21.49	59.9	40.4	73.8	N/A	30.00	28.00
188+4889	22.62	45.8	38.9	30.1	N/A	32.90	48.10
188+4874	23.34	52.1	53.5	46.4	N/A	38.90	60.90
188+4860	23.03	50.8	31.7	31.6	N/A	49.90	47.30
188+4843	23.72	56.8	44.4	36.3	N/A	43.30	45.90
188+4827	22.79	38.1	38.9	26.6	N/A	33.50	25.40
188+4813	21.37	61.3	64.1	51.2	N/A	83.50	64.80
188+4796	21.86	73.7	85.3	42.4	N/A	40.60	55.50
188+4780	19.69	58.3	73.1	46.6	N/A	40.20	40.50
188+4762	20.45	53.4	58.5	50.7	N/A	40.50	42.00
188+4748	24.95	63.7	49.3	36.3	N/A	35.10	31.90
188+4733	25.76	48.9	37.2	28.8	N/A	31.50	30.40
188+4720	21.89	60.5	44.8	32.5	N/A	34.20	31.00
188+4706	23.39	63.1	51.3	37.4	N/A	30.60	37.20
188+4689	22.09	40.7	31.5	31.3	N/A	31.90	30.40
188+4674	20.79	36.3	29.5	29.9	N/A	31.60	41.20
188+4656	21.15	41.5	33.1	31.9	N/A	31.80	29.50
188+4641	21.04	56.7	82.6	35.9	N/A	71.00	77.90
188+4626	22.82	41.8	36.2	31.8	N/A	44.90	42.50
188+4610	19.55	45.8	46.8	34.8	N/A	45.90	44.50
188+4592	20.75	72.8	64.7	35.1	N/A	39.00	66.20
188+4576	21.32	62.2	36.8	31.5	N/A	28.90	28.90
188+4562	21.32	44.1	43.1	33.3	N/A	38.60	34.30
188+4544	24.13	76.4	60.5	37.2	N/A	72.00	57.80
188+4531	20.94	62.2	50.1	36.2	N/A	38.70	34.60
188+4513	22.69	50.2	41.2	31.8	N/A	40.20	51.40
Average	22.11	54.50	48.75	37.35		41.51	43.39
Increase(%)		32.39	-5.75	-11.40		4.16	1.88

Minnesota Specified 3U18 Patch Mix

% Load Transfer

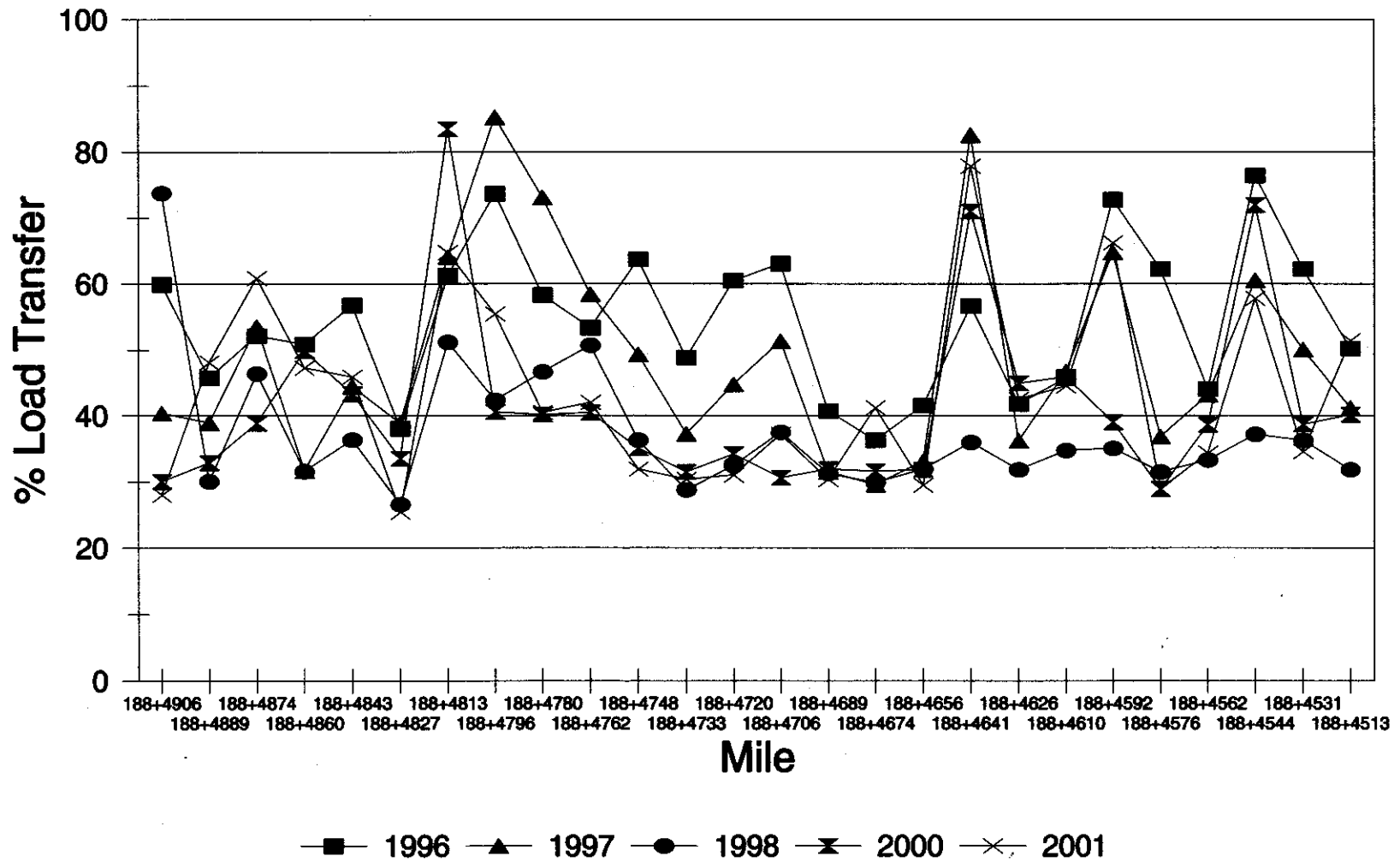

C-7

Fargo Project - IM-8-029(003)022

Typical Joints where Patchroc 10-60 was used as the patch mix material

There are two columns for 1995. The first column shows load transfer percentages before dowels were installed. The second column shows load transfer percentages just after installation.

	1995	1995	1998	1999	2000	2001
42+5274	24.12	83.29	95.6	93.40	N/A	96.50
42+5257	26.04	81.41	92.5	94.50	N/A	93.50
42+5243	21.48	90.40	93.0	95.10	N/A	94.80
42+5222	20.72	87.78	90.5	91.60	N/A	90.80
42+5202	19.89	81.44	92.2	95.00	N/A	94.20
42+5186	21.98	74.73	87.6	92.90	N/A	91.20
42+5172	21.95	88.81	94.7	95.00	N/A	96.10
42+5156	23.57	88.39	93.7	95.00	N/A	97.00
42+5137	25.95	86.48	95.4	94.20	N/A	95.70
42+5120	110.86	86.27	93.5	93.40	N/A	95.60
42+5106	19.61	84.07	95.4	95.10	N/A	96.00
42+5090	20.27	92.08	94.0	94.70	N/A	96.70
42+5069	25.20	86.72	88.1	94.80	N/A	95.10
42+5053	26.06	90.21	94.1	96.30	N/A	96.50
42+5038	25.32	88.92	95.0	96.10	N/A	95.80
42+5022	21.19	89.50	92.6	96.00	N/A	96.70
42+5004	26.65	83.14	94.7	96.20	N/A	97.10
42+4988	22.57	87.33	92.7	94.50	N/A	94.50
42+4974	28.23	91.27	90.7	95.70	N/A	94.10
42+4957	23.63	88.65	93.1	93.60	N/A	94.50
42+4940	22.75	83.84	89.3	92.70	N/A	94.30
42+4923	19.71	87.87	96.0	94.00	N/A	97.90
42+4908	21.95	81.95	93.8	95.50	N/A	96.30
42+4891	20.14	90.78	92.0	93.00	N/A	96.30
42+4872	23.66	84.00	89.2	94.00	N/A	94.10
Average*	23.03	86.38	92.75	94.54	N/A	95.24
Increase(%)		63.35	6.38	1.78		0.70

*Data point 42+5120 not included

Fargo-Patchroc 10-60 Patch Mix

% Load Transfer

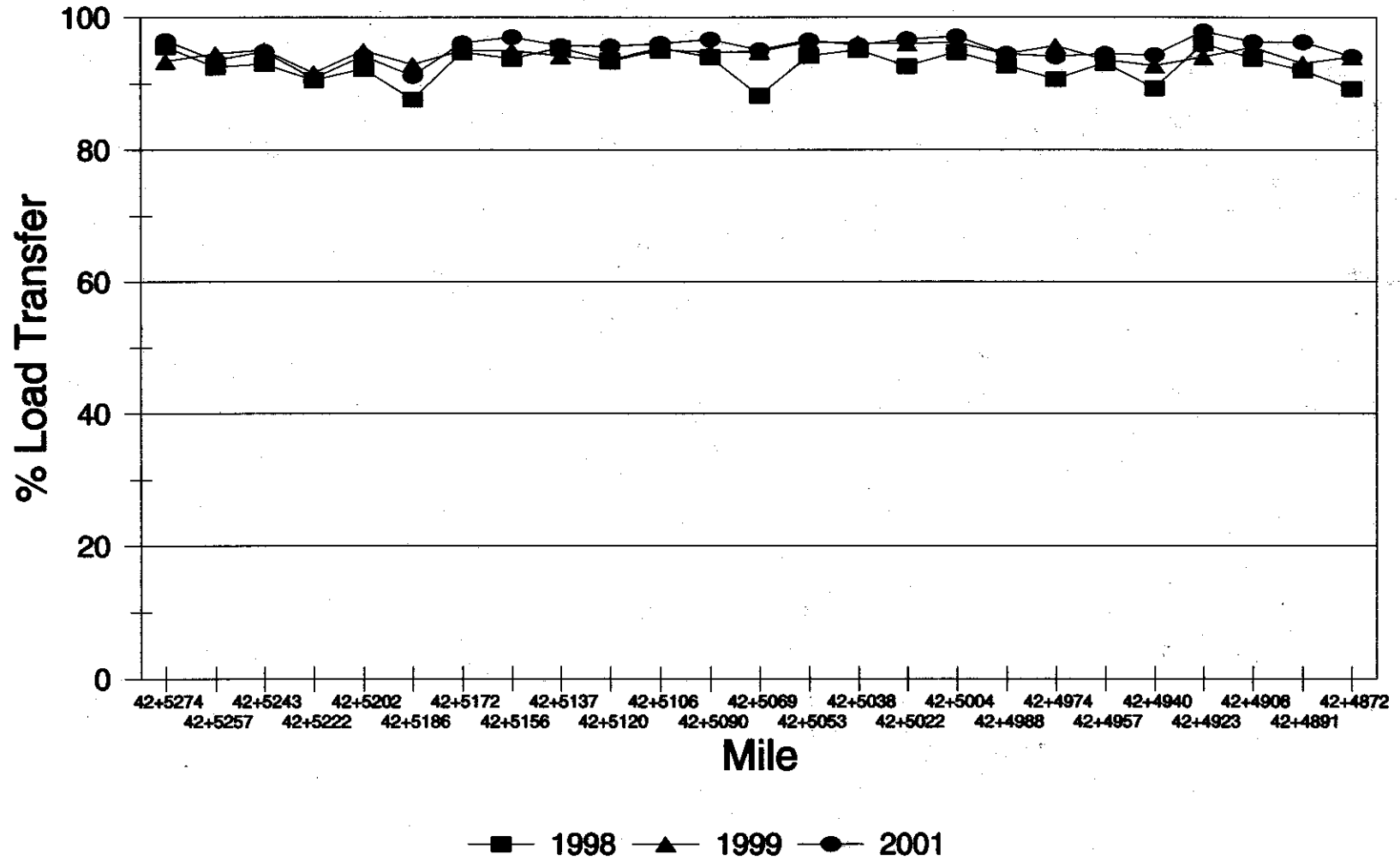

Appendix D

NORTH DAKOTA DEPARTMENT OF TRANSPORTATION

SPECIAL PROVISION

DOWEL BAR RETROFIT

IM-2-094(059)248

FEBRUARY 15, 2002

DESCRIPTION

This work consists of retrofitting epoxy-coated dowel bars into existing concrete pavement.

MATERIALS

1. Curing Compound. The curing compound shall be a wax based liquid membrane-forming compound that conforms to the requirements of AASHTO M-148 (ASTM C 309) Type 1-D or 2, Class A or B.

2. Dowel Bars. The Dowel bars shall be plain, round bars fabricated from steel meeting AASHTO M-31, M-42, or M-53. Dowel bars shall be cut to the required length and cleaned to remove all cutting burrs, loose mill scale, rust, grease, and oil. The bars may be sheared providing the deformation of the bars from true round shape does not exceed 0.04 inch in diameter or thickness, and shall not extend more than 0.04 inch from the sheared end.

Dowel bars shall be epoxy-coated 100% on all surfaces. The epoxy coating shall be in accordance with AASHTO M-284. The dowel bars shall also be shop coated with a bond breaking release agent. The bond breaking release agent shall be a curing compound meeting the requirements specified above.

The dowel bars shall have tight fitting end caps made of nonmetallic materials that allow for 1/4 inch movement of the bar at each end. The Contractor shall submit sample end caps to the Engineer prior to use.

3. Caulk. The caulk for sealing the existing transverse joint crack at the bottom and sides of the slot shall be any commercial caulk designed as a concrete sealant that is compatible with the patch material being used.
4. Foam Core Board. The foam core board shall be constructed of closed cell foam, and be faced with poster board material on each side.
5. Patching Material. "Concrete Patch Mix" shall be Patchroc 10-60, Five Star Highway Patch, Burke 928 Fast Patch, American Highway Technology's (AHT) dowel bar retrofit mortar or an approved equal. The Concrete Patch Mix shall be mixed and placed according to the Manufacturers recommendations.
6. Chairs. The chairs for supporting and holding the dowel bars in place shall be completely epoxy coated according to Section 836.02 B, or made of nonmetallic material.
7. The contractor shall provide the Department with a concrete mix design for the patching material that meets a minimum compressive strength of 4,000 psi, in six hours, prior to the beginning of work. This mix design shall include all additives and materials that will be used on the project.

CONSTRUCTION REQUIREMENTS

Prior to construction, the Contractor shall provide the project engineer with the Manufacturer's product literature for usage of the patch mix.

The Contractor shall install the dowel bars in the existing concrete pavement as shown in the Plans and according to the following specifications:

1. Slots shall be cut in the pavement with a gang saw capable of cutting a minimum of three slots in the wheel path, at a time. The slots shall be cut to the depth required to place the center of the dowel at mid-depth in the concrete slab. Multiple saw cuts parallel to the centerline may be required to properly remove material from the slot.
2. Jack hammers used to remove the concrete shall not be larger than the 30 pound class.
3. All exposed surfaces and cracks in the slot shall be sand blasted and cleaned of saw slurry and loose material before installing the dowel. All loose material will be disposed of by the Contractor off of the highway right-of-way.
4. Dowel bars shall be placed in a chair that will provide a minimum of 1/2 inch clearance between the bottom of the dowel and the bottom of the slot. The dowel bar shall be placed to the depth shown in the plans, parallel to the centerline, and parallel to pavement surface of the lower panel at the transverse joint, all to a tolerance of 1/4 inch. The chair design shall hold the dowel bar securely in place during the placement of the patch mix.
5. The contractor shall caulk the existing transverse joint crack at the bottom and sides of the slot as shown in the Plans. The transverse joint crack shall be caulked to provide a tight fit for the foam core board at the transverse joint and to prevent any of the patch mix from entering the crack at the bottom or the sides of the slot. The sealant shall not extend beyond 3/8" of each side of the existing transverse joint crack.
6. The dowel bar shall be placed through the foam core board at the specified location. The dowel bar shall be placed so a minimum of 7.0 inches is placed on either side of the transverse joint. The foam core board shall be capable of remaining in a vertical position and tight to all edges during the placement of the patch mix. If for any reason the foam core board shifts during the placement of the patch mix, the work shall be rejected and replaced at the Contractor's expense.
7. The patch material shall be mixed with a hand mixer. A metering or measuring device for the water is required. The Contractor shall assure that a consistent batch of patch mix is being produced. A mobile mixer is not acceptable.

The patching material will be tested by the Engineer at a rate of 1 test for each 4 hours of production. A minimum compressive strength of 4,000 psi in 6 hours is required. If compressive strengths are not being met, production shall cease and the Contractor shall resubmit a mix design correcting the strength problems.
8. The existing concrete surfaces inside the slotted area shall be moistened with a hand sprayer immediately prior to placing the patch mix.
9. The patch mix shall be placed into the slot and vibrated with a small hand held vibrator to insure that the patch mix completely surrounds the dowel bar.
10. The surface of the patched area shall be flushed with a curing compound that meets the requirements specified above. The curing compound shall be applied within 30 seconds after a set of 3 dowel bar patches have been finished.
11. The Contractor shall repair at their own expense any spalling that occurs to the transverse joints. The joint shall be sawed and sealed as shown in the plans.

METHOD OF MEASUREMENT AND BASIS OF PAYMENT

Installation of the Dowel Bars will be measured and paid for as "Dowel Bar Retrofit Type B" for each dowel bar installed and accepted by the Engineer. Payment shall be full compensation for all labor, equipment, and materials necessary to complete the work as specified.