

1. Report No. ND 98-04	2. Report Date February 2005	3. Contract No. N/A	4. Project No. H-8-999(003)
5. Title and Subtitle Use of Snowplowable Reflective Pavement Markers for Effective Delineation		6. Report Type Work Plan <input type="checkbox"/> Construction <input type="checkbox"/> Evaluation <input type="checkbox"/> Final <input checked="" type="checkbox"/>	7. Project No. NH-4-052(030)167 8. Project No. 9. Project No. 10. Project No.
11. Author(s)/Principle Investigator(s) Gary L. Doerr, Rhaub Walker, Steve Henrichs			
12. Performing Organization Name and Address NDDOT M+R <input checked="" type="checkbox"/> North Dakota DOT NDDOT OTHER* <input type="checkbox"/> Materials and Research Division NDSU <input type="checkbox"/> 300 Airport Road UND <input type="checkbox"/> Bismarck ND 58504-6005 UGPTI <input type="checkbox"/> OTHER* <input type="checkbox"/> *see supplementary notes		13. Sponsoring Agency Name and Address North Dakota DOT Materials and Research Division 300 Airport Road Bismarck ND 58504-6005	
14. Supplementary Notes			
15. Abstract Purpose and Need A supplement to the primary pavement marking system, is to install snowplowable reflective pavement markers. A snowplowable reflective pavement marker would provide additional delineation when the primary marking system is reliable and provide a backup system during times when the primary marking system is unreliable. It is also imperative that the raised pavement marker be resistant to the effects of snowplow activity. Objective The objective of this study is to determine, primarily, the performance of the Stimsonite Reflective Pavement Marker when exposed to snowplow activity. Performance characteristics of the reflector itself will be studied to determine what supplemental benefits it has to the primary pavement markings. Scope Two experimental sections of Stimsonite Lifelite snowplowable raised reflective markers were installed. One section was installed on an urban Interstate highway exit ramp and the other section was installed on the turning lanes of a rural highway. These sections will be evaluated annually for four years. The reflective markers will be visually evaluated for wear and damage; and section personnel will be interviewed about the snowplowability and visibility of the raised reflective markers. The first set of raised reflective markers was placed on the southeast exit ramp (ramp 67) of the Intersection of I-29 and 19th Avenue North in Fargo, North Dakota as part of project H-8-999(003). I-29 is classified as a Rural Interstate Highway. The second set of raised markers were placed on US 52 approximately two miles southeast of Harvey, North Dakota at the intersection into a grain elevator terminal from RP 171.983 to RP 172.366 on project NH-4-052(030)167. US 52 is classified as a Interregional corridor. Summary Before a chip seal was placed on the US 52 test section, users of the grain handling facility near Harvey indicated that the markers were a great benefit in assisting the drivers to identify the lane markings in all types of weather. The section personnel indicated that the markers showed up very well after sanding even when the paint markings are totally obscured with the sand. A chip seal was placed on the US 52 test section and its application has reduced the visibility of the raised markers. Masking a larger area around the raised markers may have reduced the loss of visibility caused by the chip seal. The markers at the Interstate 29 ramp installation are in a location that doesn't appear to greatly affect the delineation of the ramp. The markers are located outside the painted yellow edge line and aren't very visible to traffic. The markers at both sites have shown some deterioration from age and wear from snowplows but the markers generally appear to be intact. Damage to the ears of the markers doesn't appear to have affected the performance of the markers. The only damage that has affected the visibility of the markers is damage to the lenses. At the Interstate ramp installation 1 of the 12 markers has a damaged lens and 4 of the 108 markers at the US 52 installation have damaged lenses.			
16. Key Words Traffic Control Raised Markers	17. Distribution Statement No restrictions. This document is available to the public from: North Dakota Department of Transportation Materials and Research Division: 300 Airport Road Bismarck ND 58504-6005 Office: (701) 328-6900		18. No. of Pages 30 19. File type/Size Pdf/ 2.1 MB

**NORTH DAKOTA
DEPARTMENT OF TRANSPORTATION**

**MATERIALS AND RESEARCH
DIVISION**

Experimental Study ND 98-04

**Use of Snowplowable Reflective Pavement
Markers for Effective Delineation**

Final Report

H-8-999(003)
NH-4-052(030)167

February 2005

Prepared by

NORTH DAKOTA DEPARTMENT OF TRANSPORTATION

BISMARCK, NORTH DAKOTA

Website: <http://www.discovernd.com/dot/>

DIRECTOR

Dave Sprynczynatyk, P.E.

MATERIALS AND RESEARCH DIVISION

Ron Horner

EXPERIMENTAL PROJECT REPORT

EXPERIMENTAL PROJECT	EXPERIMENTAL PROJECT NO.					CONSTRUCTION PROJ NO		LOCATION		
	1	STATE ND	YEAR 98	NUMBER - 04	SURF	H-8-999(003) 8 NH-4-052(030)167		Cass & Wells 28 Counties		
	EVALUATION FUNDING					NEEP NO.	PROPRIETARY FEATURE?			
	48	1 X	HP&R	3	DEMONSTRATION		X Yes			
		2	CONSTRUCTION	4	IMPLEMENTATION	49	51 No			
SHORT TITLE	TITLE 52 Use of Snowplowable Reflective Pavement Markers for Effective Delineation									
THIS FORM	DATE	MO.	YR.	REPORTING						
	140	02	--	2005	1	INITIAL	2	ANNUAL	3 X	FINAL
KEY WORDS	KEY WORD 1				KEY WORD 2					
	145 TRAFFIC				167 CONTROL					
	KEY WORD 3				KEY WORD 4					
	189 RAISED MARKERS				211					
	UNIQUE WORD				PROPRIETARY FEATURE NAME					
	233				255 STIMSONITE 101 LP					
CHRONOLOGY	Date Work Plan Approved		Date Feature Constructed:		Evaluation Scheduled Until:		Evaluation Extended Until:		Date Evaluation Terminated:	
	03-1998		08-1999		08-2004					
	277		281		285		289		293	
QUANTITY AND COST	QUANTITY OF UNITS (ROUNDED TO WHOLE NUMBERS)			UNITS				UNIT COST (Dollars, Cents)		
	120			1 LIN. FT 2 SY 3 SY-IN 4 CY				5 TON 6 LBS 7 X EACH 8 LUMP SUM		
	297			305				306		
AVAILABLE EVALUATION REPORTS	CONSTRUCTION			PERFORMANCE				FINAL		
	X			X				X		
	315									
EVALUATION	CONSTRUCTION PROBLEMS				PERFORMANCE					
	1 NONE 2 SLIGHT 3 X MODERATE 4 SIGNIFICANT 5 SEVERE				1 EXCELLENT 2 GOOD 3 X SATISFACTORY 4 MARGINAL 5 UNSATISFACTORY					
	318				319					
APPLICATION	1 ADOPTED AS PRIMARY STD.		4 PENDING		<i>(Explain in remarks if 3, 4, 5, or 6 is checked)</i>					
	2 X PERMITTED ALTERNATIVE		5 REJECTED							
	320		3		ADOPTED CONDITIONALLY 6 NOT CONSTRUCTED					
REMARKS	321 Of the total of 120 markers placed, only five markers were damaged enough to effect their visibility. The raised markers were able to improve the delineation of the lanes at the US 52 installation but were not in a position to improve delineation at the interstate ramp installation. The application of a chip seal greatly reduced the visibility of the raised markers at the US 52 installation. Raised markers are recommended for locations with unusual or unexpected geometry.									

Experimental Study ND 98-04

**Evaluation of Snowplowable Reflective Pavement
Markers for Effective Delineation**

Final Report

Project ND 98-04

February 2005

Written by
Gary L. Doerr
Rhaub Walker
Steven Henrichs

Disclaimer

The contents of this report reflect the views of the author or authors who are responsible for the facts and the accuracy of the data presented herein. The contents do not reflect the official views of the North Dakota Department of Transportation or the Federal Highway Administration. This report does not constitute a standard, specification, or regulation.

TABLE OF CONTENTS

Purpose and Need	1
Objective	2
Scope	2
Location	3
Project Historical Information	4
Design	4
Construction	5
First Evaluation	6-8
Second Evaluation	9-10
Third Evaluation	11-12
Fourth Evaluation	13
Summary	14
Recommendation	15
Appendix A: Project Plans and Notes	A-1
Appendix B: LifeLite 101 LP Specifications	B-1

Evaluation of Snowplowable Reflective Pavement Markers for Effective Delineation

Purpose and Need

There are many roadway segments in North Dakota that include sharp curves or unlighted areas that require caution when encountering them. Nighttime conditions sometimes make it difficult to identify markings, especially if the marking system is worn. Due to climatic conditions, pavement marking paints can wear off completely before maintenance forces can reapply the marking.

An alternative, to supplement the primary pavement marking system, is to install snowplowable reflective pavement markers. A snowplowable reflective pavement marker would provide additional delineation when the primary marking system is reliable and provide a backup system during times when the primary marking system is unreliable. It is also imperative that the raised pavement marker be resistant to the effects of snowplow activity. Photo 1 shows an uninstalled Stimsonite Lifelite 101 LP raised reflective pavement marker.



Photo 1- Stimsonite Lifelite 101 LP marker before installation.

Objective

The objective of this study is to determine, primarily, the performance of the Stimsonite reflective pavement marker when exposed to snowplow activity. Performance characteristics of the reflector itself were studied to determine what supplemental benefits it has to the primary pavement markings.

Scope

Two experimental sections of Stimsonite Lifelite snowplowable raised reflective markers were installed. One section was installed on an Interstate highway exit ramp and the other section was installed on the turning lanes of a rural highway. The reflective markers were visually evaluated for wear and damage; and section personnel were interviewed about the raised markers' visibility and their effect on snow plows.

Location

The first set of raised reflective markers was placed on the southeast ramp of the 19th Avenue North interchange on I-29 (Exit 67) in Fargo, North Dakota as part of project H-8-999(003). I-29 is classified as a Rural Interstate Highway.

The second set of raised markers was placed on US 52 approximately two miles southeast of Harvey, North Dakota at the entrance of a grain elevator terminal from RP 171.983 to RP 172.366 as part of project NH-4-052(030)167. US 52 is classified as an Interregional corridor.

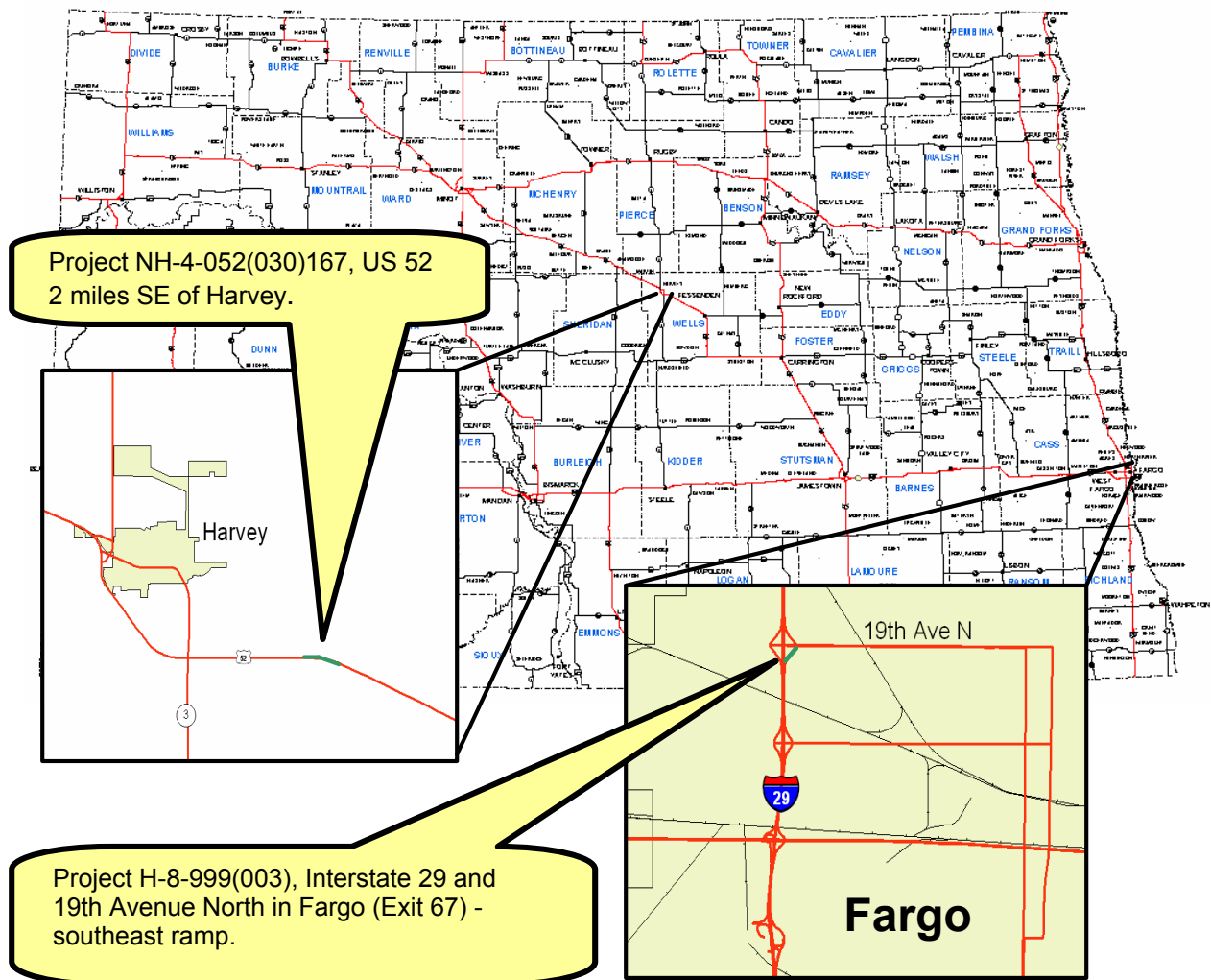

Figure 1 - Project Location.

Project Historical Information

Traffic

The two-way traffic for US 52 is shown in Table 1.

Year	Passenger Car	Trucks	Total	30TH Max Hr	Flex. ESALs
1998	1,100	360	1,460	150	315
2002	1,280	385	1,665	170	335
2004	1,280	385	1,665	170	335

Table 1

The AADT of the southeast ramp of Interstate 29 exit 67 was 5,600 in 2002. The one-way traffic is shown in table 2.

Year	Passenger Car	Trucks	Total	30TH Max Hr	Rigid. ESALs
2004	6,670	80	6,750	675	60

Table 2

Design

Stimsonite Lifelite 101LP raised reflective pavement markers are approximately 10"x5.5"x1.76" and weigh approximately 5.5 pounds. They have a cast iron housing with a plastic prismatic reflector installed in it. They can be installed in existing HBP or PCC surfaces by milling out the necessary material and then being epoxied into place. After installation, the units should protrude out of the pavement no more than a quarter of an inch, thereby providing a low ramp angle and small impact area when exposed to snowplow blades.

The first location of the experimental study is located on a ramp section in an urban setting. The markers supplement the solid yellow line representing the left edge line of an exit ramp.

The second section of roadway is located 2 miles east of Harvey along US 52. This is a HBP roadway and is on a horizontal curve that includes turn lanes for a grain terminal. Markers were installed to complement the existing pavement marking system.

The markers placed contained reflectors that were two-way yellow, white/red or one-way white. Appendix A contains the plans for project NH-4-052(030)167.

Construction

The first installation of the Stimsonite pavement markers took place on August 18, 1998 and was located on the southeast exit ramp of Interstate 29 (Exit 67). The markers used on this experimental section were equipped with one-way yellow reflectors. A grinding machine fitted with 18" and 20" diameter blades was used to cut slots into the pavement. Two-part epoxy, was used to secure the markers into the pavement, and was mixed by hand.

Just after the grinding process was completed, the state inspector commented that several of the markers did not rest totally on the four leveling tabs. This is very important since this assures that the leading edges of the marker are below the pavement surface. After approaching the contractor on this condition the contractor responded that this was normal since the pavement surface is not always perfectly smooth and should not pose a problem. Twelve markers were installed.

Construction of the experimental section on US 52 took place on August 25, 1999 and September 15, 1999. At this installation, the contractor also mixed the epoxy by hand. Excess epoxy material was used in the installation in almost every case for these markers. The excess material was spread over the surrounding asphalt making a large gray "patch" that draws attention to the installation. Some of the excess material pooled in front of the reflectors, which may affect the amount of light that can reach the reflectors. This may decrease the distance through which the reflectors are effective. Photo 2 shows the typical installation of the Stimsonite raised pavement marker at the US 52 site. A total of 108 markers were eventually installed at this location.



Photo 2 - A typical installation of a raised pavement marker.

Evaluation

First Evaluation

The first evaluation was completed in 2001. One marker on the US 52 installation was partially removed because it was too high and caused some damage to a district snowplow. District Section personnel subsequently removed the portion of the marker that was too high. The marker is shown in Photo 3.



Photo 3 - A marker that had been partially removed by Section personnel.

Some of the markers at the I-29 ramp had cracks or breaks at one of the ears that the marker rests on. No obvious reason for the damage was evident. The cracked and broken ears were all in the edge that the snowplow would hit first. Photo 4 shows a marker with a broken ear. There was no traffic or snowplow damage to any of the markers' reflectors. All of the markers on the I-29 installation were in place and serviceable. Some oxidation of the metal casting had occurred but not to the extent that it had become a problem.

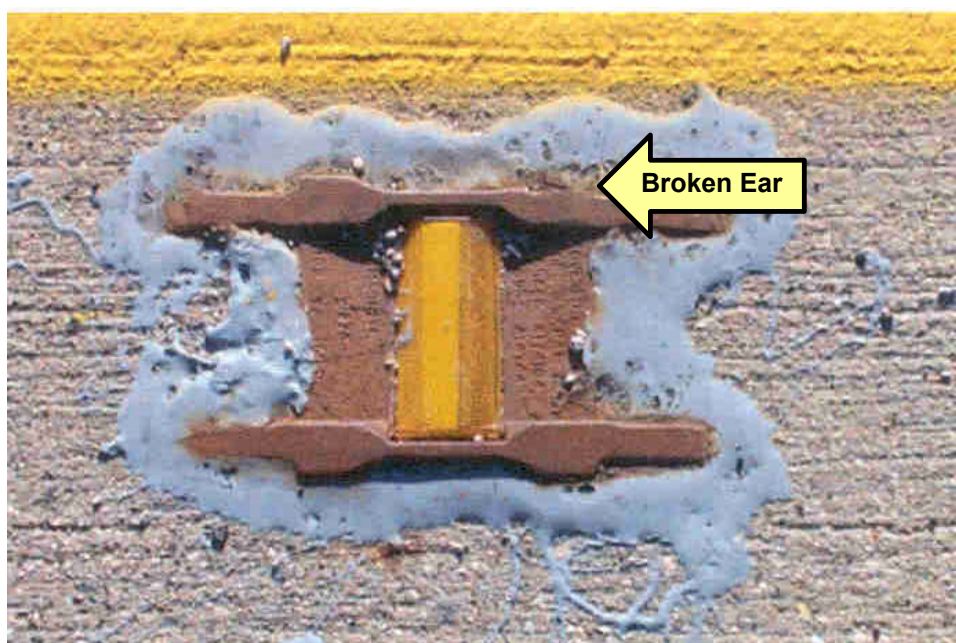

Photo 4 – Marker with broken upper right ear.

In both installations the epoxy was mixed by hand. Some mixing problems were evident at the time of installation but no debonding was evident at this evaluation.

During interviews with the Minot District maintenance personnel in the Harvey Section, they indicated that sanding during the icy winter months did not affect the visibility of the markers. Evidently the sloped face of the markers prevents them from being obscured by the sand. The Harvey Section personnel also have had favorable comments from the users of the grain terminal along the US 52 installation.

The installation at the I-29 ramp seemed to collect sand in the area adjacent to the reflectors and is shown in photo 5. This may be due to the fact that traffic tends to use the inside of the curve and does not drive next to the markers, which could blow the material out of the recesses. The location of the markers, outside the yellow striping on the outside of the curve, makes them nearly invisible. Because the traffic is only on one side of the markers, the slush seems to build up and cover the markers during thawing weather.



Photo 5 - Debris in recess of marker.

Section personnel from the Fargo District indicated that the markers are extremely bumpy during plowing activities (The markers were most noticeable with maintainer plows during compacted snow/ice removal). With these markers being on

the high side of the ramp and the outside of the curve, they got covered with slush and sand by the passing cars which moved the material to the outside of the curve.

Second Evaluation

The second evaluation for the US 52 section was conducted on August 14, 2002 and the evaluation for the Interstate 29 ramp was conducted on September 9, 2002. Generally, the markers at both locations were in good condition and were serviceable. A marker, on US 52, had some damage to its top. This damaged marker is next to the marker that was removed by Minot District personnel the year before. Photo 6 shows the condition of this marker. Four other markers, on US 52, had cracked or damaged reflectors. Damage to the ears of the markers has continued. Five of the markers on the Interstate 29 ramp had damaged ears and 18 markers on US 52 had broken or cracked ears. The casings have continued to oxidize but are intact. Photo 7 shows an oxidized marker with a cracked ear. Some epoxy has chipped or cracked but this does not appear to be a problem.



Photo 6 – A damaged marker at the US 52 test section.



Photo 7 – Marker with oxidized casing and a broken lower right ear.

Damage to the markers may be due to the markers not being installed level and even with the pavement. It was noted, at the installation of markers at the Interstate 29 ramp that the markers were not even with the pavement. Uneven installation was probably responsible for a portion of one marker being removed because the marker was too high and also for damage to the top of an adjacent marker. A lack of contact with the pavement may be contributing to the damage to the ears. The ears are relatively thin tabs of metal and without pavement contact they are in an exposed and unsupported position.

During the second evaluation, Minot Section personnel had positive comments about the performance of the raised markers. They said that the raised markers greatly aided visibility of the lane markings and did not cause any maintenance difficulties other than that the snowplows had to operate at slower speeds.

Third Evaluation

The third evaluation for the US 52 section was conducted on September 22, 2003 and the evaluation for the Interstate 29 ramp was conducted on August 13, 2003. The US 52 section had been chip sealed in the summer of 2002. The raised markers had been masked during the application of the chip seal but chip seal material partially obscured the reflectors of many of the raised markers and in some instances, the highest point of the raised marker was lower than the surrounding chip seal. Minot Section personnel stated that the raised markers were still visible at night but not as visible as before application of the chip seal. They also stated that the raised markers had much less effect on the snowplows. Photo 8 and Photo 9 show the condition of the raised markers after application of the chip seal. To have avoided reducing visibility of the raised markers, the chip seal material should have been kept several feet away from the reflector.

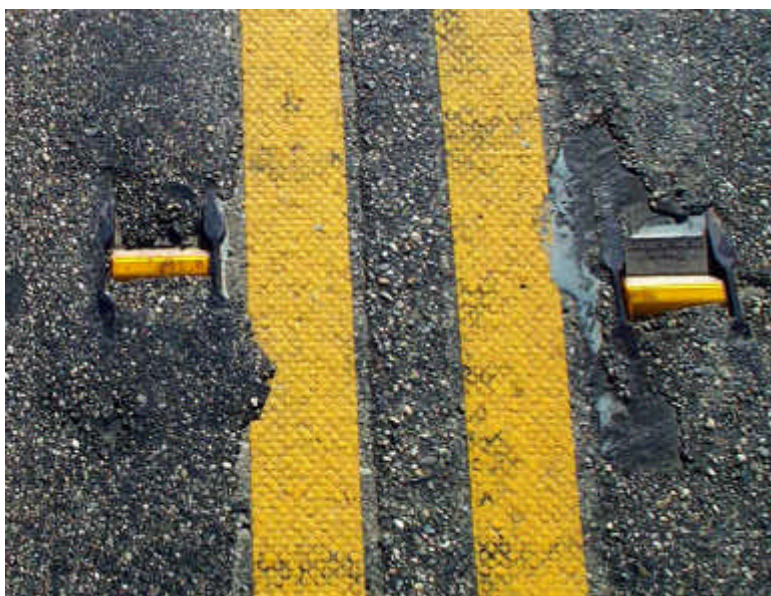

Photo 8 – Two raised markers that are partially obscured by chip seal material.



Photo 9 – A raised marker on the US 52 test section after application of a chip seal.

Damage to the raised markers has increased since the second evaluation. Nine raised markers had damaged ears at the Interstate 29 ramp and two markers had cracked lenses. It didn't appear that the damage was affecting the visibility of any of the raised markers at the interstate 29 ramp. The US 52 section had 38 raised markers with damaged ears and three with damaged lenses (including the marker that had been partially removed by maintenance forces in 2000). The lens of one other raised marker had been partially removed and is shown in Photo 10. Chip seal material covered many of the ears and their condition could not be assessed. The large increase in cracked ears at the US 52 section may be because snowplow speeds have increased since the chip seal was applied. The snowplows may now operate at higher speeds because very little of the cast iron housing is above the surface of the pavement. The ear of the cast iron housing is on the portion of the marker that typically remains above the pavement surface.



Photo 10 – A marker with a broken lens at US 52.

Fourth Evaluation

The fourth evaluation of the Interstate 29 ramp installation was completed on September 2, 2004 and the evaluation of the US 52 installation was completed on November 24, 2004. All of the raised markers had damaged ears at the Interstate 29 ramp and two markers had cracked lenses. One other marker had a heavily damaged lens and is shown in Photo 11. Damage to the US 52 section remained unchanged from the previous evaluation. Thirty-eight raised markers had damaged ears and there remained a total of four markers with damaged lenses (including the marker that had been partially removed by maintenance forces in 2000). It was difficult to assess the number of broken ears because many of them were covered by the chip seal material. At both sites, the lenses of some of the markers had become somewhat cloudy but the cloudiness didn't appear to greatly affect the performance of the lenses.

A project is scheduled for 2006 that will reconstruct the ramp at the Interstate 29 ramp installation. There are no current plans to reinstall the raised markers.



Photo 11 – A marker with a damaged lens at the Interstate 29 ramp installation.

Summary

Before a chip seal was placed on the US 52 test section, users of the grain handling facility near Harvey indicated that the markers were a great benefit in assisting the drivers to identify the lane markings in all types of weather. The section personnel indicated that the markers showed up very well after sanding even when the paint markings are totally obscured with the sand. A chip seal was placed on the US 52 test section and its application has reduced the visibility of the raised markers. Masking a larger area around the raised markers may have reduced the loss of visibility caused by the chip seal.

The markers at the Interstate 29 ramp installation are in a location that doesn't appear to greatly affect the delineation of the ramp. The markers are located outside the painted yellow edge line and aren't very visible to traffic.

The markers at both sites have shown some deterioration from age and wear from snowplows but the markers generally appear to be intact. Damage to the ears of the markers doesn't appear to have affected the performance of the markers. The only damage that has affected the visibility of the markers is damage to the lenses. At the Interstate ramp installation 1 of the 12 markers has a damaged lens and 4 of the 108 markers at the US 52 installation have damaged lenses.

Maintenance personnel emphatically stated that they had to slow down while plowing as the vibration was felt inside the cab and damage to the plows could result.

Recommendation

The snowplowable raised reflective pavement markers at both sites were able to resist damage from snowplows. Of the total of 120 markers placed, only five markers were damaged enough to effect their visibility. The damage to most of these markers may be repaired by replacing the lenses of the markers. The raised markers were able to improve the delineation of the lanes at the US 52 installation but were not in a position to improve delineation at the Interstate 29 ramp installation.

Snowplowable raised reflective pavement markers are recommended for locations with unusual or unexpected geometry that require a greater degree of delineation than average. Recommended locations would include areas where lanes divide, merge, or narrow. Preferable locations would be locations where snowplows already operate at a reduce speed.

The application of a chip seal greatly reduced the visibility of the raised markers at the US 52 installation. Because the application of a chip seal can greatly affect the visibility of the raised markers, either the area around the raised marker should be masked or the area completely avoided.

Appendix A

JOB# 14

FHWA REGION	STATE	PROJECT NO.	SHEET NO.
8	ND	NH-4-052(030)167 NH-3-052(026)185	1

NORTH DAKOTA DEPARTMENT OF TRANSPORTATION

FEDERAL AID PROJECTS NH-4-052(030)167 & NH-3-052(026)185
IN WELLS COUNTY
HOT BITUMINOUS PAVEMENT & INCIDENTALS

GOVERNING SPECIFICATIONS:

Standard Specifications adopted by the North Dakota Department of Transportation October 1997; Standard Drawings currently in effect; and other Contract Provisions submitted herein.

LENGTH OF PROJECT

	MILES-Gross	MILES-Net
NH-4-052(030)167	17.415	17.370
NH-3-052(026)185	13.141	13.141

.045 Mi deducted for Bridges (NH-4-052(030)167)

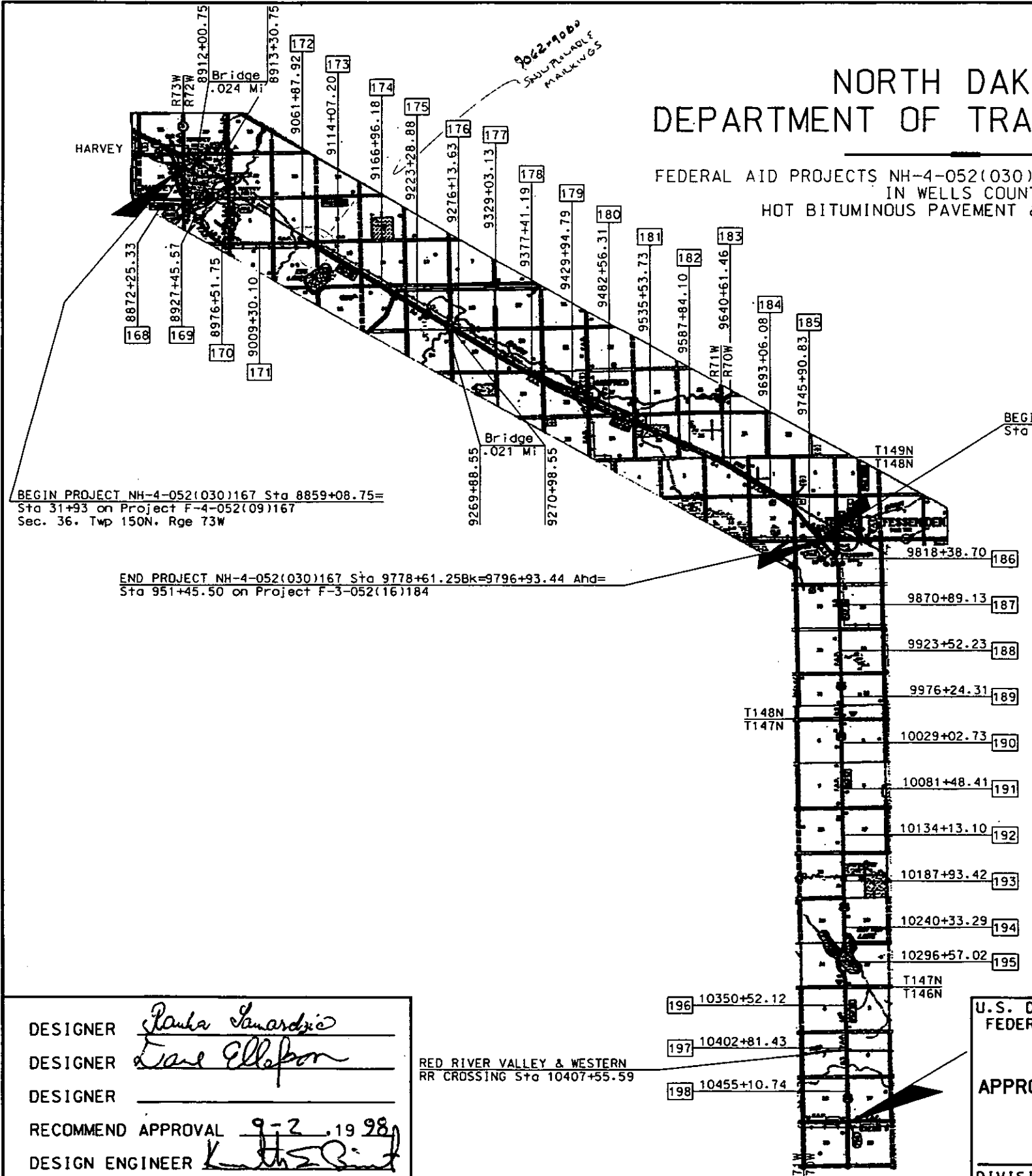

DESIGN DATA for NH-4-052(030)167				
Traffic	Average Daily		TOTAL	Est. 30th Max. Hour
Current (1998):	1.100 Pass.	360 Trucks	1.460	150
Forecast (2018):	1.540 Pass.	580 Trucks	2.120	225
Design Speed:	70 MPH			
Minimum Sight Distance for Stopping:	625'			

DESIGN DATA for NH-3-052(026)185				
Traffic	Average Daily		TOTAL	Est. 30th Max. Hour
Current (1998):	760 Pass.	300 Trucks	1.060	110
Forecast (2018):	1.070 Pass.	480 Trucks	1.550	160
Design Speed:	70 MPH			
Minimum Sight Distance for Stopping:	625'			

DESIGNER Paula Samardic
 DESIGNER Lane Ellefson
 DESIGNER _____
 RECOMMEND APPROVAL 9-2-1998
 DESIGN ENGINEER [Signature]

RED RIVER VALLEY & WESTERN
RR CROSSING Sta 10407+55.59

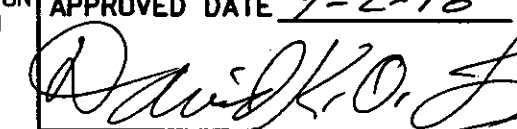
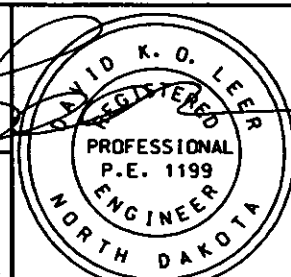
U.S. DEPARTMENT OF TRANSPORTATION FEDERAL HIGHWAY ADMINISTRATION APPROVED DIVISION ADMINISTRATOR _____ DATE _____	APPROVED DATE <u>9-2-98</u>  DIRECTOR OF HIGHWAYS AND ENGINEERING	
	NORTH DAKOTA DEPARTMENT OF TRANSPORTATION	

FHWA REGION	STATE	FED. AID PROJ. NO.	SHEET NO.
8	N.D.	NH-4-052 (030) 167	4

NOTES

NH-3-052 (026) 185

105-P01 The contractor shall notify the local utility companies prior to the beginning of construction, so they may determine the location of all utilities in the project area.

107-P01 HAUL ROADS: Paved county roads in all the area counties shall not be used as haul roads.

200-P01 SHRINKAGE: 25 percent additional volume in yardage computed by the end-area method is allowed for shrinkage in earth embankment.

202-P01 REMOVAL OF BITUMINOUS SURFACING: All cost to remove the bituminous surfacing and the aggregate base from mainline shoulders from Sta 9061+75.72 to Sta 9080+39.72 shall be included in the unit price bid for "Removal of Bituminous Surfacing."

203-P01 FLATTEN DITCH BLOCK SLOPES: The slopes of the ditch blocks shall be flattened to 10:1. The embankment material required to flatten the slopes will be compacted in accordance with Section 203.02 I of the Standard Specifications. The topsoil shall be stripped from both the embankment and excavation areas, stockpiled, and replaced when the work is complete. Both areas shall be seeded with Class II mix. The embankment may be obtained within the right-of-way areas approved by the engineer. Embankment not available within the right of way will need to be obtained from borrow. The contractor shall furnish the borrow. The cost of obtaining the site and the borrow shall be included in the price for "Flatten Ditch Block Slopes." If one or both slopes of the ditch block are flattened, only one unit will be paid for. The cost of excavation, compaction of embankment, stripping, replacing topsoil, and seeding will be included in the price bid for "Flattened Ditch Block Slopes" each.

203-P02 APPROACH INSLOPE RECONSTRUCTION: The cost of labor, equipment, and materials to perform the following work will be included in the price bid for "Approach Inslope Reconstruction."

- 1) Strip and stockpile 3" of topsoil from the embankment and excavation areas.
- 2) Flatten the approach inslope steeper than 6:1 to 8:1. The material used to flatten the slope will be compacted in accordance with Section 203.02 I of the Standard Specifications. When available, the embankment material may be obtained within the right of way in locations approved by the engineer. Embankment not available within the right of way will need to be obtained from borrow. The contractor shall furnish the borrow. The cost of obtaining the site and the borrow shall be included in the price for "Approach Inslope Reconstruction."
- 3) Replace the topsoil on both the excavation and embankment areas and seed with Class II seed mixture in accordance with Section 708.02 of the Standard Specifications.

Payment will be made for each approach inslope that is flattened. For example, if both inslopes of an approach are flattened, two units will be measured and paid for.

203-P03 BORROW FOR TURN LANES AT ELEVATOR APPROACH: The borrow required for turn lanes widening is not available within the highway right of way. It will be the contractor's responsibility to obtain the borrow. All disturbed areas shall be seeded with Class II seed mixture in accordance with Section 708.02 of the Standard Specifications. The cost of labor, equipment, and materials to perform the seeding will be included in the price bid for "Borrow."

401-P01 MC 70 or 250 liquid asphalt shall not be measured and paid for separately but will be included in the price bid for "Hot Bituminous Pavement QC/QA Cl 31."

409-P01 HOT BITUMINOUS PAVEMENT: The 3½-inch hot bituminous pavement shall be paver laid in two approximately equal lifts. The 2½-inch hot bituminous pavement shall be paver laid in one lift. The cold longitudinal joint in the bituminous pavement shall only be allowed within one foot of centerline.

FHWA REGION	STATE	FED. AID PROJ. NO.	SHEET NO.
8	N.D.	NH-4-052(030)167	5

NOTES

NH-3-052(026)185

410-P01 MILLING BITUMINOUS PAVEMENT: All material milled under the bid item "Milling Bituminous Pavement" shall become the property of the contractor and shall be disposed of off the right of way.

704-252 TRAFFIC CONTROL FOR UNEVEN PAVEMENT: The contractor has the option of making the paving lanes even at the end of each day's paving operation or signing for the uneven pavement and providing the following devices: Install "Uneven Lanes" signs (Sign No. W8-11-48) and a supplemental plate (Sign No. W20-52-54), identifying the distance, on the right shoulder (both directions) in advance of the beginning of the uneven pavement and at major intersections. A major intersection shall be defined as a CMC, State, U.S., or Interstate ramp. Install "Do Not Pass" signs (Sign No. R4-1-48) on the right shoulder (both directions) between the uneven lanes sign and the beginning of the uneven pavement and at major intersections. Install tubular markers at 200-foot intervals on the centerline where uneven pavement exists.

These traffic control devices shall be left in place until the lanes are even. These signs and tubular markers are included in the "Traffic Control Devices List" and will be measured and paid for at the contract unit price for each device. No extra compensation will be allowed for relocation due to work progression.

704-P01 The traffic-control devices list has been developed using the following layouts on the standard drawings for traffic control:

Std. D-704-15, Layout Type A for the hot bituminous paving operation and milling.

Std. D-704-20, Layout Type G for construction sign layout.

Std. D-704-22, Layout Types K and L for construction trucks hauling material.

Std. D-704-26, Layout Types CC, FF, and GG for the hot bituminous pavement operation.

704-P02 The quantities for traffic control include 64 delineator drums for marking areas of guardrail removal and installation.

704-P03 The traffic control devices list contains 292 vertical panels to mark the drop-off at the edge of the driving lanes during the shoulder removal and widening from Sta 9064+75.72 to Sta 9079+40.72.

704-P04 TRAFFIC CONTROL: Construction traffic control devices shall be in accordance with Standard D-704-24, Type U and Type T for flattening approach sideslope. If it becomes necessary to close a lane on mainline, a Type F sign layout as shown on Standard D-704-19 shall be used. All signs shall be removed during non-working hours.

708-P01 TEMPORARY EROSION CONTROL: Temporary erosion control has been provided for placement prior to disturbing the topsoil. 100 LF of ditch checks have been provided at Sta. 9072+15.72 where adding turn lanes three miles east of Harvey.

714-P01 PIPE CULVERTS: If an existing pipe end requires repair before the extension can be made, the contractor shall remove or straighten the damaged length of pipe to a point where the extension can be made. Regardless of the method used to prepare the existing pipe ends, the pay length will be measured from the point on the existing pipe where the repaired damage or removal begins to the end of the new extension. The pipe lengths as shown on the quantity sheet have been calculated assuming the contractor has removed the damaged ends. The cost of straightening existing pipe ends or removing them shall be included in the price bid for "Pipe Culverts."

The lengths of pipe culverts shown on the quantity sheet are for bidding purposes only. It is the contractor's responsibility to determine the exact length of pipe extension to meet the requirements shown on the typical approach detail.

714-P02 CMP EXTENSIONS: The corrugated metal connecting bands for relay end sections and extensions of corrugated metal pipe shall be furnished by the contractor. The cost of

FHWA REGION	STATE	FED. AID PROJ. NO.	SHEET NO.
8	N.D.	NH-4-052(030)167	6

NOTES

NH-3-052(026)185

- the bands is to be included in the price bid for "Corrugated Steel Pipe Culverts."
- 714-P03 The removal and resetting of the fence to accomplish the extension of the concrete cattle pass at RP 169.076 shall not be measured and paid for separately, but will be included in the unit price bid for "Cattle Pass Concrete Intermediate Section."
- 754-050 SIGN SUPPORTS: The sign supports "Steel Galvanized Posts - Square Tube Perforated" were designed using a minimum yield strength of 55,000 psi and the design requirements of the "Standard Specifications for Structural Supports for Highway Signs, Luminaires, and Traffic Signals." The wind speed of 75 mph was used. The square telescoping steel posts shall have all holes punched completely. All metal shall be removed from the punched holes.
- 762-151 PREFORMED PATTERNED PAVEMENT MARKING: The preformed patterned pavement marking shall be rolled into the hot asphalt surface. The contractor shall arrange to have the preformed patterned pavement markings placed on the hot asphalt in the position shown on the plans at the time rolling operations are being done. The preformed patterned pavement markings shall receive at least two rollings.
- The cost of placing and rolling the pavement markings into the hot asphalt pavement shall be included in the price bid for the item "Preformed Patterned Pavement Marking Line or Message."
- 762-P01 RAISED PAVEMENT MARKER: The raised pavement markers shall be Stimsonite Model 101LP Raised Reflective Snowplowable Pavement Marker or equal. The location of raised pavement markers shall be as shown in the plans and installed as recommended by the manufacturer.
- The raised pavement markers will be measured by the number of markers installed. All labor, material, and equipment necessary to install the markers shall be included in the price bid for "Raised Pavement Markers."
- 764-P01 REMOVED GUARDRAIL MATERIALS: The removed box beam guardrail and end treatment and transitions shall be delivered to the NDDOT maintenance storage yard in Harvey.
- All costs associated with delivery of these materials to the maintenance storage yard shall be included in the price bid for the items "Remove Box Beam Guardrail" and "Remove End Treatment and Transition."
- 764-P02 EMBANKMENT FOR GUARDRAIL INSTALLATION: The embankment material required for guardrail installation is not available within the highway right of way. It will be the contractor's responsibility to obtain embankment material. The existing topsoil shall be removed from the area to be disturbed, stockpiled, and replaced when embankment is completed. The disturbed areas shall be seeded with a seed mixture of 50 percent brome grass, 50 percent crested wheat grass at a rate of 25 pounds pure live seed per acre. Fertilizers shall be applied at a rate of 20 pounds phosphorous and 20 pounds nitrogen per acre. Compaction of the embankment shall be in accordance with Section 203.02 I of the Standard Specifications. The inslopes in areas that are to be widened shall be benched in accordance with Section 203.02 F of the Standard Specifications unless otherwise directed by the Engineer. All existing drainage patterns shall be maintained. This may involve some excavation and ditch widening. The embankment will be measured by the number of sites complete and in place. A site is defined as the area of embankment needed to place a completed guardrail on as shown in the plans.
- The cost for any excavation to maintain the drainage patterns and for benching, seeding, salvaging, stockpiling, and spreading of the topsoil shall be included in the price bid for "Guardrail Embankment, Type C."

Appendix B

STIMSONITE

"Continuing to make our roads visibly safer!"

LIFELITE 101

LOW-WAY SNOWFLOWABLE, RECYCLABLE, REFLECTIVE PAVEMENT MARKER

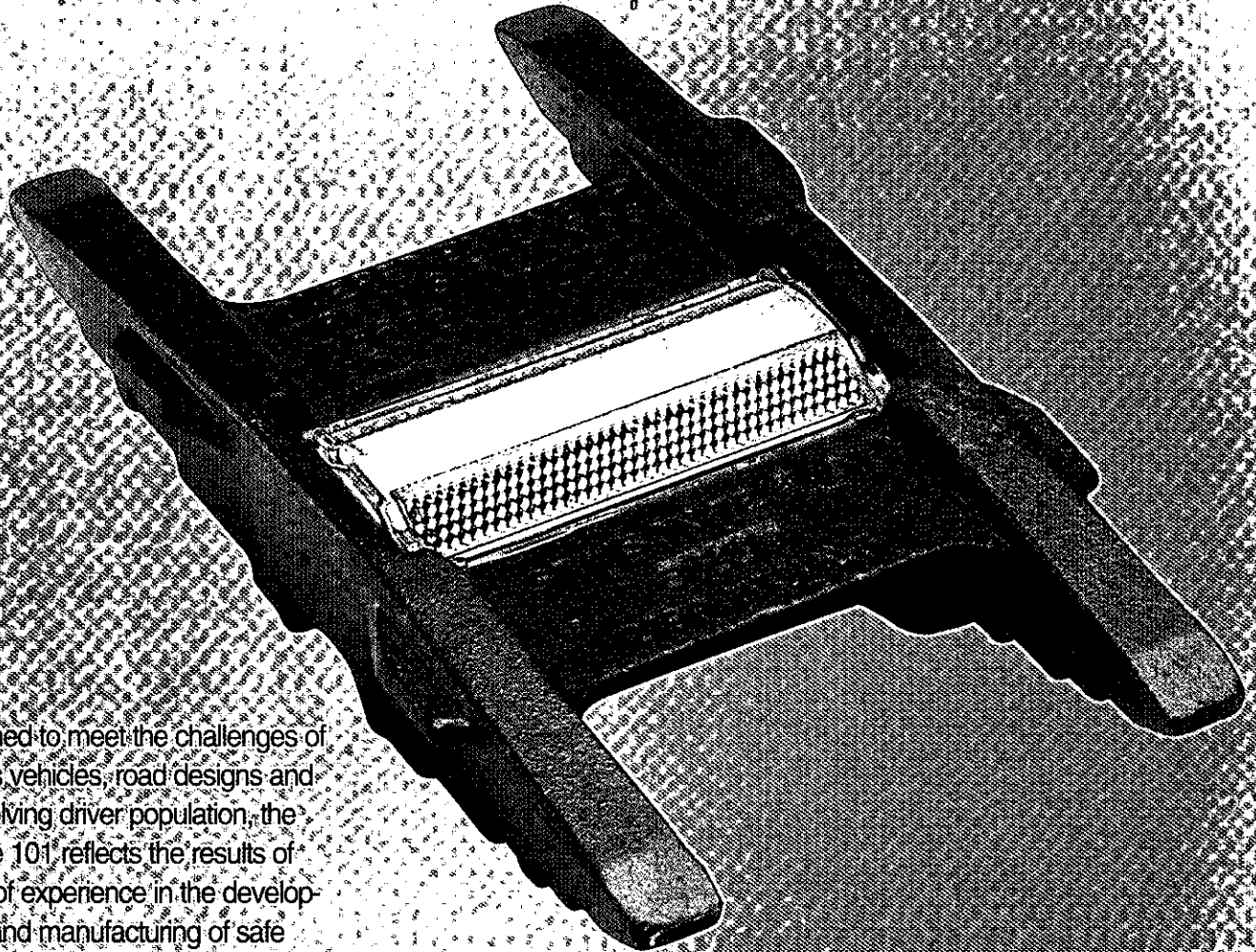

Designed to meet the challenges of today's vehicles, road designs and an evolving driver population, the LifeLite 101 reflects the results of years of experience in the development and manufacturing of safe and effective snowplowable pavement markers.

Highest reflectivity: With a Specific Intensity of 3.0 cd/lc, LifeLite 101 markers provide the industry's highest visibility guidance in wet or dry weather conditions, with full reflective strength from distances of 1,000 feet or more.

Improved plowability: A low ramp angle and narrower design provide better plowability. Smaller impact area, round corners and low profile design combine to reduce reflector damage.

Low Installation and Maintenance Costs: LifeLite 101's narrower anchoring base saves on the cost of pavement-cutting blades and epoxy adhesive. The Model 944 reflector is also easy to replace.

Longest Life Reflector: Unique glass-face design allows vehicle tires to better wipe reflector clean and extends its life cycle.

Guaranteed Recyclability: Marker castings returned to Stimsonite can be economically cleaned and reconditioned to like new condition.

For availability and specification on the LifeLite 101 or LifeLite 101LP (our low profile version for areas where frequent high speed plowing is encountered), or any of our other highway safety products, contact:

STIMSONITE

Stimsonite Corporation
7542 N Natchez Ave
Niles, Illinois 60714-3804 USA
Phone: 847-647-7717
FAX: 847-647-1205
world wide web:
<http://www.stimsonite.com>

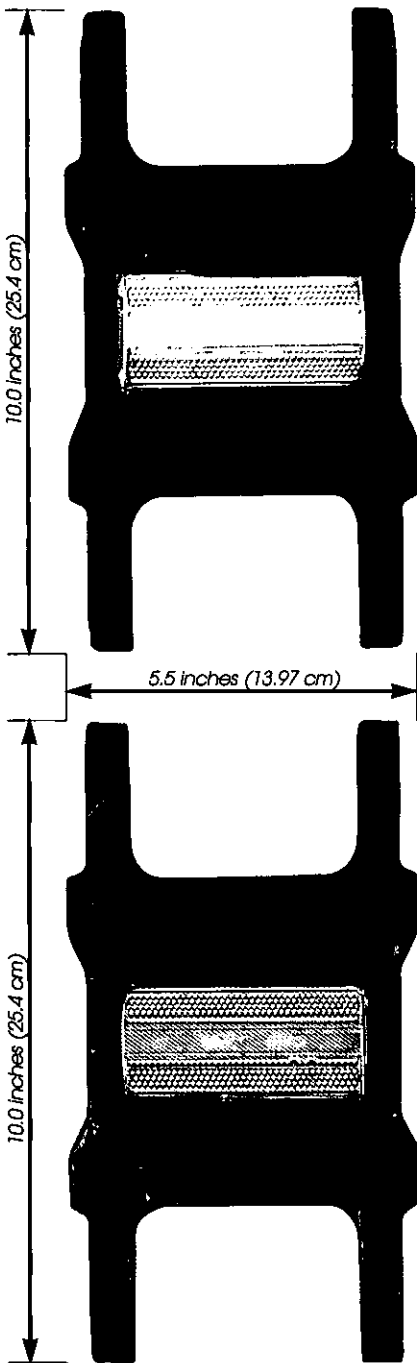

Specifications

Material: Cast iron housing with acrylic plastic prismatic reflector.

Size: 101: 10.0" long x 5.5" wide x 1.92" high (25.4 x 13.97 x 4.88 cm); 0.41" (1.04 cm) maximum height above roadway.
101LP: 10.0" long x 5.5" wide x 1.76" high (25.4 x 13.97 x 4.47 cm); 0.25" (0.64 cm) maximum height above roadway.

Weight: Approximately 5.5 lb. (2.49 kg)

Reflective Area: 1.87 square inches (12.06 square cm)

Specific Intensity (at 0.2° observation angle):

White: 3.0 at 0° entrance angle; 1.2 at 20° entrance angle

Yellow: 60% of values for white.

Red: 25% of values for white.

Detailed specifications and samples are available for inspection.

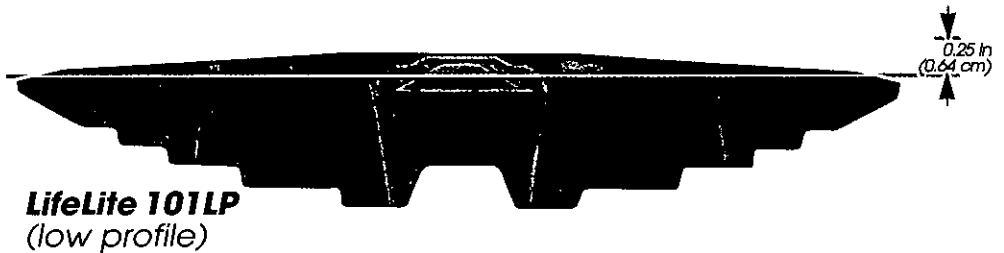
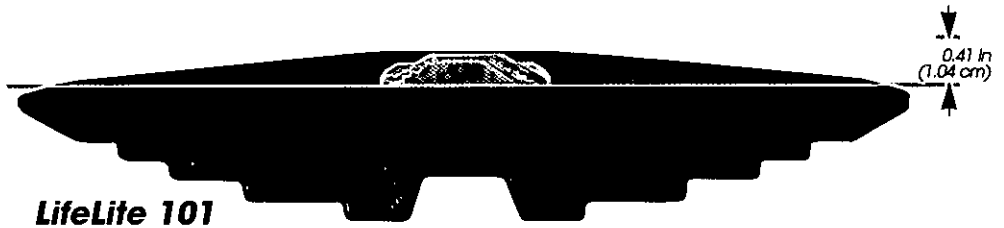

How To Order

When ordering use the following part numbers to designate the model and color you desire:

Model Number	Description	Reflector
101 or 101LP AW	Two-way reflective White	944 AW
101 or 101LP AY	Two-way reflective Yellow	944 AY
101 or 101LP ERW	Two-way reflective Red/White	944 ERW
101 or 101LP ERY	Two-way reflective Red/Yellow	944 ERY
101 or 101LP BW	One-way reflective White	944 BW
101 or 101LP BY	One-way reflective Yellow	944 BY

Other colors are available on special order. For one-way, plowable models specify Stimsonite Model 94.

Where To Order

Stimsonite Corporation

7542 N Natchez Ave
Niles, Illinois 60714-3804 USA
Phone: 847-647-7717
FAX: 847-647-1205
<http://www.stimsonite.com>

Stimsonite

Australia (Pty) Ltd

10/128 Canterbury Rd
Kilsyth 3137
Victoria, Australia
Phone: 61-3-9761-5677
FAX: 61-3-9761-5680

Stimsonite Europa Ltd

The Stables
Clevedon Hall East, Victoria Rd,
Clevedon, North Somerset
BS21 &SD United Kingdom
Phone: 44-01275-341123
FAX: 44-01275-341169

STIMSONITE®

Making Highways Visibly Safer Since 1916.

Copyright © 1996 Stimsonite Corporation. All Rights Reserved.

LIFELITE 101

Designed to meet the challenges of today's vehicles, road designs and an evolving driver population, the LifeLite 101 reflects the results of years of experience in the development and manufacturing of safe and effective snowplowable pavement markers.

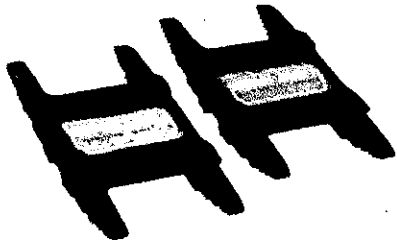

TWO-WAY SNOWPLOWABLE REFLECTIVE PAVEMENT MARKERS

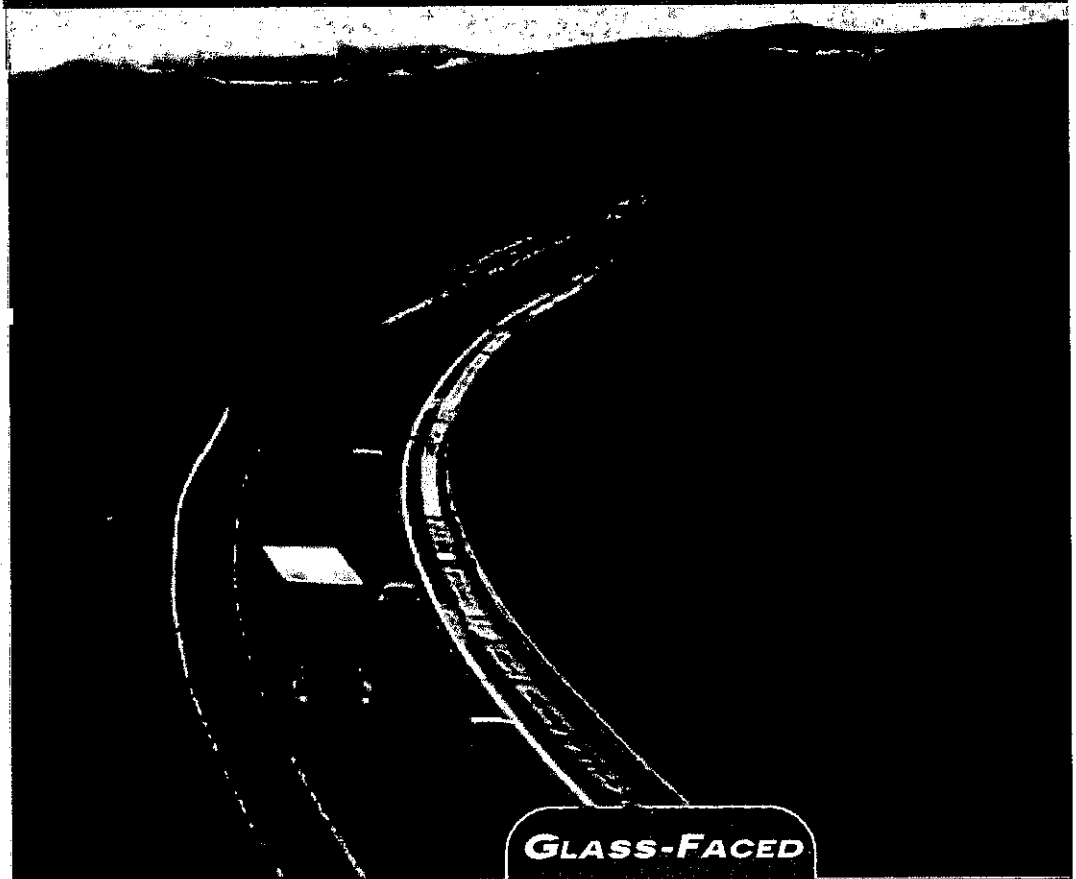

GLASS-FACED

Highest Reflectivity

With a specific intensity of 3.0 cd/lc, the Stimsonite® brand LifeLite 101 markers provide the industry's highest visibility guidance in wet or dry weather conditions, with full reflective strength from distances of 1,000 feet or more.

Improved Plowability

A low ramp angle and narrow design provide better plowability. Smaller impact area, round corners and low-profile design combine to reduce reflector damage.

Low Installation and Maintenance Costs

LifeLite 101's narrower anchoring base saves on the cost of pavement-cutting blades and epoxy adhesive. The LifeLite 944 reflector is also easy to replace.

Longest Life Reflector

Unique glass-face design allows vehicle tires to better wipe reflector clean and extends its life cycle.

Guaranteed Recyclability

Marker castings returned to Avery Dennison can be economically cleaned and reconditioned to be nearly like new.

Availability

For availability and specifications on LifeLite 101 or LifeLite 101LP (our low profile version for areas where frequent high-speed plowing is encountered), or any of our other highway safety products, contact the Avery Dennison customer support center at 1-800-327-5917.

LIFELITE 101



LIFELITE 101 A
Both faces are reflective in the same color. Available in white, yellow, or in special order colors.



LIFELITE 101 B
One face is reflective for monodirectional viewing. Slightly lower cost than "A" units. Available in standard colors or special order colors.



LIFELITE 101 E
Provides dual-purpose, two-way, two-color reflectorization for controlling wrong-way movement on divided highways or exit/entrance ramps. Supplied in any combination of white, red, yellow, or to meet special requirements for color coding.

TWO-WAY SNOWPLOWABLE REFLECTIVE PAVEMENT MARKERS

SPECIFICATIONS

Materials: Cast iron housing with acrylic plastic prismatic reflector.

Weight: Approximately 5.5 lb. (2.49 kg)

Size: 101 10.0" long x 5.5" wide x 1.92" high
(25.4 cm x 13.97 cm x 4.88 cm)
.41" (1.04 cm) maximum height

Reflective area: 1.87 sq. in. (12.06 cm²)

101LP 10.0" long x 5.5" wide x 1.76" high
(25.4 cm x 13.97 cm x 4.47 cm)
.25" (.64 cm) maximum height above roadway

Optical performance (at 0.2° observation angle):

White 3.0 at 0° entrance angle
1.2 at 20° entrance angle
Yellow 60% of the values for white
Red 25% of the values for white

Detailed specifications are available for inspection

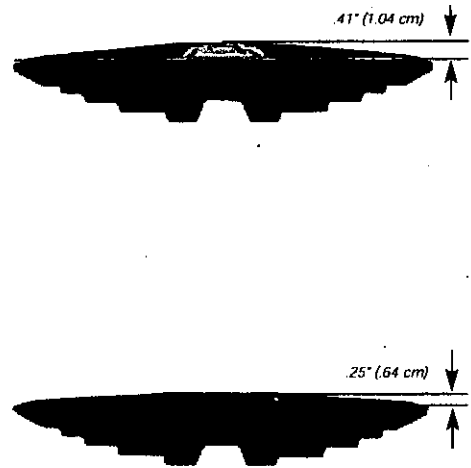
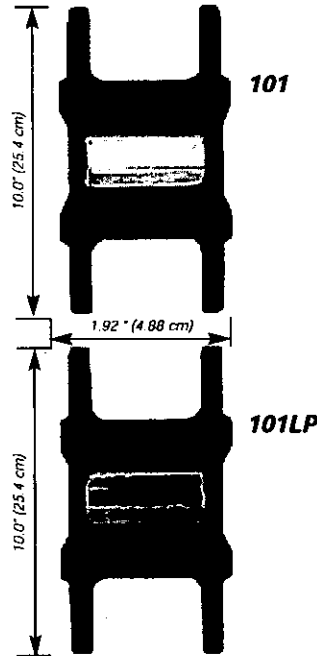

HOW TO ORDER

When ordering, use the following part numbers to designate the model and color you desire:

Description	Model	Reflector
Two-way reflective White	101 or 101LP AW	944 AW
Two-way reflective Yellow	101 or 101LP AY	944 AY
Two-way reflective Red/White	101 or 101LP ERW	944 ERW
Two-way reflective Red/Yellow	101 or 101LP ERY	944 ERY
One-way reflective White	101 or 101LP BW	944 BW
One-way reflective Yellow	101 or 101LP BY	944 BY

Other colors available on special order.

Highway Safety Division
6565 West Howard
Niles, Illinois 60714 USA
1-800-327-5917
Phone 847-647-7717 FAX 847-647-2310
www.averyreflectives.com



ISO 9001 CERTIFIED Avery Dennison is ISO 9001 certified for the design and manufacture of raised reflective pavement markers

© 2000 Avery Dennison Corporation. Avery Dennison is a registered trademark of Avery Dennison Corporation. All other brands and product names are trademarks of their respective companies. ADI/ISPL101-0200-5M