

1. Report No. ND 98-03	2. Report Date August 2004	3. Contract No. N/A	4. Project No. IM-8-029(025)053
5. Title and Subtitle Vegetation Barriers Around Headwalls of Edge Drains		6. Report Type Work Plan <input type="checkbox"/> Construction <input type="checkbox"/> Evaluation <input type="checkbox"/> Final <input checked="" type="checkbox"/>	7. Project No. IM-2-094(016)240 8. Project No. IM-5-094(008)071 9. Project No. 10. Project No.
11. Author(s)/Principle Investigator(s) Mike Marquart			
12. Performing Organization Name and Address NDDOT M+R <input checked="" type="checkbox"/> NDDOT OTHER* <input type="checkbox"/> NDSU <input type="checkbox"/> UND <input type="checkbox"/> UGPTI <input type="checkbox"/> OTHER* <input type="checkbox"/> *see supplementary notes		13. Sponsoring Agency Name and Address North Dakota DOT Materials and Research Division 300 Airport Road Bismarck ND 58504-6005	
14. Supplementary Notes			
15. Abstract Purpose and Need The present practice to outlet drainage pipe is to place a 4" PVC outlet pipe approximately every 250 feet. This 4" PVC discharge pipe is capped with a headwall splash block, which often becomes blocked with debris to the point where it hinders the drainage system. Objective The objective of this experimental feature is to determine if constructing vegetation barriers around the headwalls of edge drain systems would help solve the problem of vegetation and debris from blocking the drain. Scope Construction of two types of head wall barriers on three projects across the state will provide performance data needed for a full evaluation. Three projects have been selected to receive the vegetation barriers. <u>IM-8-029(025)053</u> Mile 58 to 59, <u>IM-2-094(016)240</u> Mile 243 to 244, and <u>IM-5-094(008)071</u> Mile 76 to 77. The experimental feature will be evaluated and a report written annually with a final report after five years. The evaluation will include construction costs, construction problems, performance, advantages/disadvantages, and amount of vegetation and debris in each type of section. Summary The vegetation barriers were designed to include an 18-inch wide band of either aggregate or concrete around the headwall. Three projects were selected for the experimental barriers and each project will be briefly summarized. At this time, the concrete vegetation barriers are performing better than the aggregate vegetation barriers. M-5-094(008)071 The vegetation barriers look good after the fifth year of operation. Vegetation is growing out of the aggregate barriers in 20 out of 21. Some sediment is building up behind the screens in some headwalls. The biggest problem is the vegetation growing in the aggregate barriers. The vegetation growth in aggregate barriers covers 45 to 90 percent of the barrier. No mowing problems were encountered with the experimental vegetation barriers. IM-2-094(016)240 With slow vegetation growth and heavy rains some soil has eroded from around a few drains. In many aggregate barriers, the aggregate is being move away from the headwall by passing mowers and other vehicles exposing the sides of the headwall. The vegetation growth in the aggregate barriers covers 15 to 80 percent of the barrier. Concrete barriers are performing excellent. Jamestown maintenance section reports no problems mowing over or around the barriers. AC-IM-8-029(025)053 All of the aggregate barriers have been switched over to concrete barriers due to safety concerns. Mowers could pick up rocks and cast them around. This could pose a hazard to the traveling public. Many of the barriers on this project are lower than the surrounding soil due to wet conditions at the time of construction, which did not allow equipment to landscape properly. The concrete barriers are aesthetically pleasing and are performing satisfactorily.			
16. Key Words Drainage Outlets Pipes Maintenance	17. Distribution Statement No restrictions. This document is available to the public from: North Dakota Department of Transportation Materials and Research Division: 300 Airport Road Bismarck ND 58504-6005 Office: (701) 328-6900 Fax: (701) 328-0310		18. No. of Pages 60 19. File type/Size Pdf / 2.6

**NORTH DAKOTA
DEPARTMENT OF TRANSPORTATION**

**MATERIALS AND RESEARCH
DIVISION**

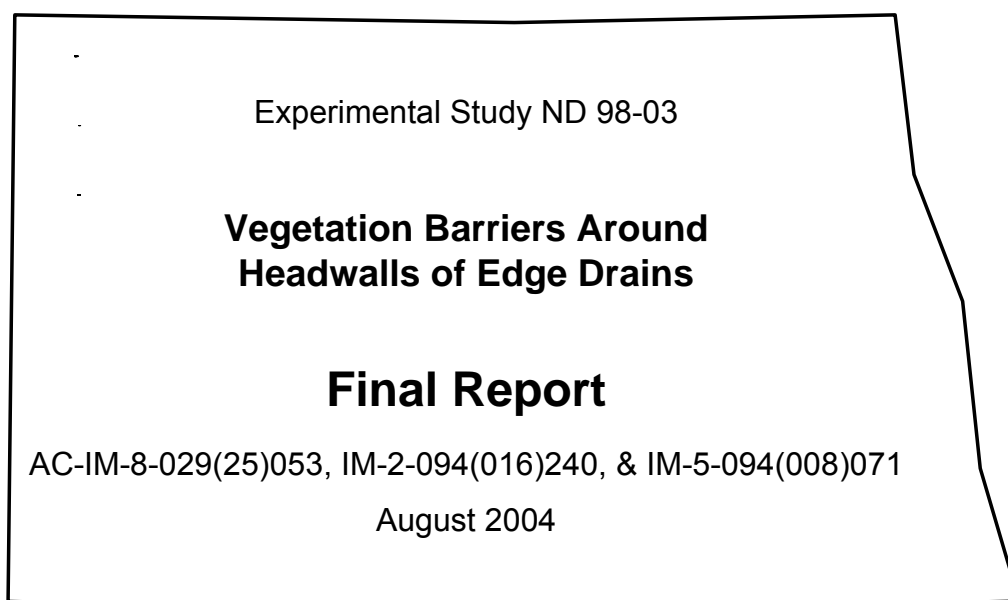

Prepared by

NORTH DAKOTA DEPARTMENT OF TRANSPORTATION
BISMARCK, NORTH DAKOTA
Website:<http://www.discovernd.com/dot>

DIRECTOR
David A. Sprynczynatyk, P.E.

MATERIALS AND RESEARCH DIVISION
Ron Horner

EXPERIMENTAL PROJECT REPORT

EXPERIMENTAL PROJECT	EXPERIMENTAL PROJECT NO.					CONSTRUCTION PROJ NO		LOCATION		
	1	STATE ND	YEAR 98	NUMBER -	03	SURF	IM-8-029(025)053 IM-2-094(016)240 IM-5-094(008)071	Stutsman & Stark & Cass Counties		
	EVALUATION FUNDING						NEEP NO.	PROPRIETARY FEATURE?		
48	1	X	HP&R	3	DEMONSTRATION		Yes			
	2		CONSTRUCTION	4	IMPLEMENTATION	49	51	X	No	
SHORT TITLE	TITLE 52 Vegetation Barriers Around Headwalls of Edge Drains									
THIS FORM	DATE	MO.	YR.	REPORTING						
	140	07	--	04	1	INITIAL	2	ANNUAL	3	FINAL
KEY WORDS	KEY WORD 1				KEY WORD 2					
	145 Drainage				167 Pipes					
	KEY WORD 3				KEY WORD 4					
189 Outlets				211						
UNIQUE WORD				PROPRIETARY FEATURE NAME						
233 Maintenance				255						
CHRONOLOGY	Date Work Plan Approved		Date Feature Constructed:		Evaluation Scheduled Until:		Evaluation Extended Until:		Date Evaluation Terminated:	
	02-98		10-98		2003				10 - 2003	
277	281		285		289		293			
QUANTITY AND COST	QUANTITY OF UNITS (ROUNDED TO WHOLE NUMBERS)			UNITS				UNIT COST (Dollars, Cents)		
	350.00			1 LIN. FT 2 SY 3 SY-IN 4 CY				5 TON 6 LBS 7 X EACH 8 LUMP SUM		
	297			305				306		
AVAILABLE EVALUATION REPORTS	CONSTRUCTION			PERFORMANCE			FINAL			
	315 X			X			X			
EVALUATION	CONSTRUCTION PROBLEMS				PERFORMANCE					
	1 NONE 2 X SLIGHT 3 MODERATE 4 SIGNIFICANT 5 SEVERE				1 EXCELLENT 2 GOOD 3 X SATISFACTORY 4 MARGINAL 5 UNSATISFACTORY					
318	319									
APPLICATION	1 ADOPTED AS PRIMARY STD.			4 PENDING		(Explain in remarks if 3, 4, 5, or 6 is checked)				
	2 PERMITTED ALTERNATIVE			5 REJECTED						
320	3 ADOPTED CONDITIONALLY			6 NOT CONSTRUCTED						
REMARKS	321 The aggregate and concrete barriers cost about the same to construct. The concrete barriers are providing good performance while the aggregate barriers range from marginal to satisfactory. A few cracks have developed in some concrete barriers. The aggregate barriers after four years of service are becoming over grown with vegetation. Cut vegetation has a tendency to stay on the headwall where on concrete barriers it tends to blow off. No maintenance charges were claimed for either type of barrier. Aggregate barriers are not recommended.									

Experimental Study ND 98-03

**Evaluation of Vegetation Barriers Around
Headwalls of Edge Drains**

Final Report

Projects:

AC-IM-8-029(025)053

IM-2-094(016)240

IM-5-094(008)071

August 2004

Written by

Mike Marquart

Disclaimer

The contents of this report reflect the views of the author or authors who are responsible for the facts and the accuracy of the data presented herein. The contents do not reflect the official views of the North Dakota Department of Transportation or the Federal Highway Administration. This report does not constitute a standard, specification, or regulation.

TABLE OF CONTENTS

Objective	1
Project Location	1
Design	3
Construction	3
IM-5-094(008)071	4
IM-2-094(016)240.....	7
AC-IM-8-029(025)053	10
Evaluation	12
IM-5-094(008)071	15
IM-2-094(016)240.....	15
AC-IM-8-029(025)053	16
Summary	16
Recommendation	18
Appendix A -- IM-5-094(008)071	
Project plans and details for edge drain pipe and splash blocks	A-1 to A-7
Appendix B -- IM-2-094(016)240	
Plan sheets, vegetation barrier details, concrete mix design	B-1 to B-8
Appendix C -- AC-IM-8-029(025)053	
Plan sheets, change order, vegetation barrier details, fabric certification..	C-1 to C-14
Change Order (1999), explanation of change order, construction details	C-15 to C-19

VEGETATION BARRIERS AROUND HEADWALLS OF EDGE DRAINS

Objective

The present practice to discharge water from drainage pipe is to place a 4" PVC outlet pipe approximately every 250 feet. This 4" PVC discharge pipe is capped with a headwall splash block, which often becomes blocked with debris to the point where it hinders the drainage system.

The objective of this experimental feature is to determine if constructing vegetation barriers around the headwalls of edge drain systems will help solve the problem of vegetation and debris from blocking the drain.

Project Location

Three projects were selected to receive the experimental vegetation barriers. This was done to obtain data, which would represent different areas across the state. Each project has a one-mile test section as shown below. Refer to Figure 1 on the next page for a location map.

AC-IM-8-029(025)053	Mile 58 (sta.3062+37) to Mile 59 (sta.3115+15)
IM-2-094(016)240	Mile 243 (sta.12829+89) to 244 (sta.12882+70)
IM-5-094(008)071	Mile 76 (sta.4013+12) to Mile 77 (sta.4066+53)

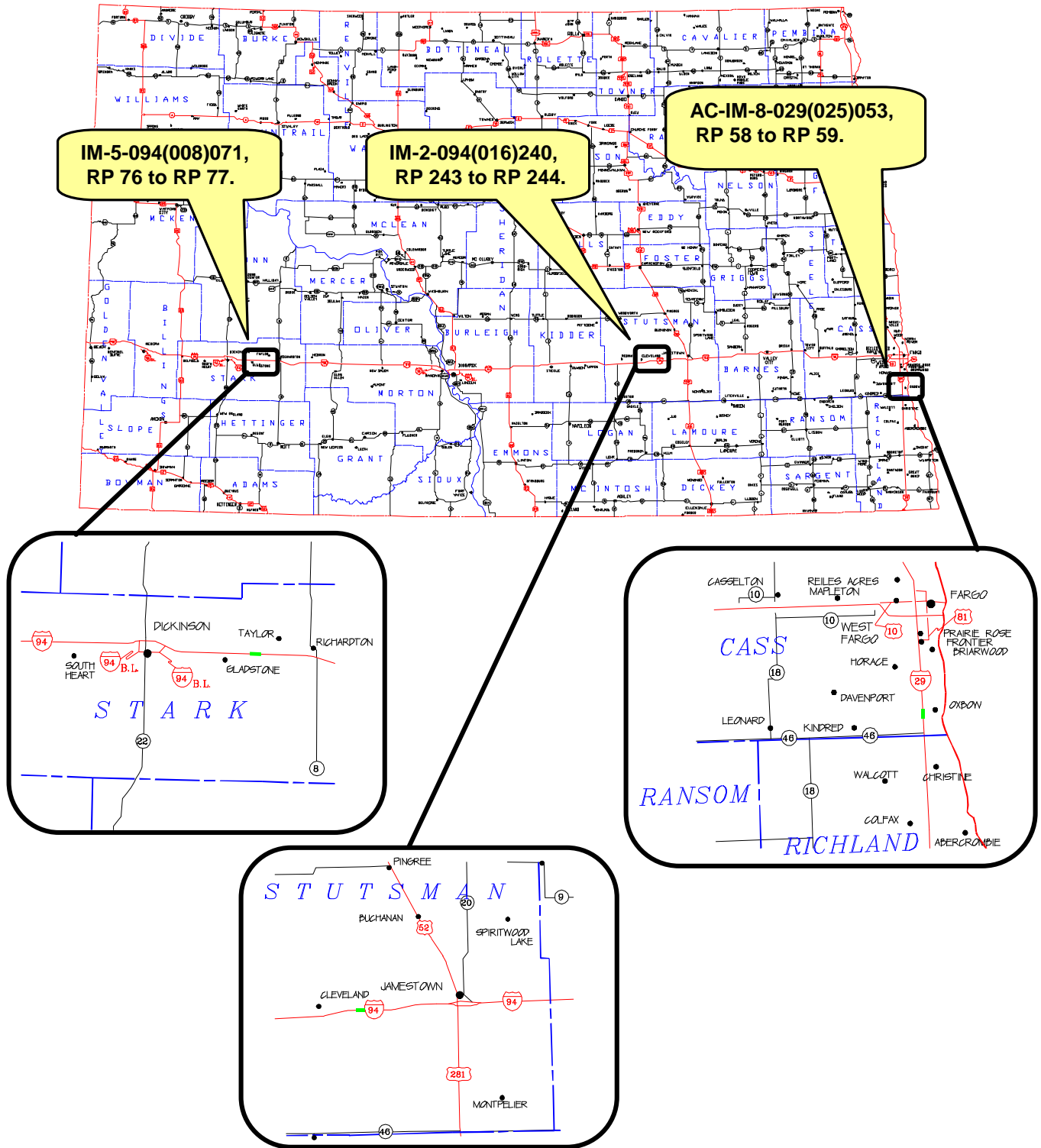

Figure 1 - Location Map.

Design

The standard designs for edge drain pipe and splash block details are located in Appendix A. This design does not have a vegetation barrier around the headwall of the edge drain outlet. The new design proposes a 4-foot by 6-foot vegetation barrier around each edge drain headwall. Two types will be constructed, one using concrete and one using aggregate.

The concrete barrier will be four inches thick. The concrete will be placed on top of the soil and is to be reinforced with six by six inch wire mesh. The wire mesh is to be placed two inches below the surface of the concrete. Vegetation barriers will use a Class YE concrete as specified in Section 802 of the “NDDOT Standard Specifications for Road and Bridge Construction”, 1997 edition.

The aggregate barrier will be six inches in depth. A geotextile fabric meeting the properties of a S2 specification will be placed under the aggregate. The aggregate is a modified version used by the Kentucky Transportation Cabinet and shall meet the following gradation.

Sieve Size - Percent Passing	
3"	100
2½"	90 - 100
¾"	0 - 5

Table 1

Construction

Although the basic design was followed, changes were made on two of the projects to accommodate construction procedures and to fit the 6:1 inslope ditch grade. Double discharge splash blocks were used on two projects. On these projects the vegetation barriers were increased in size to accommodate the extra headwall. Each project will be addressed separately.

IM-5-094(008)071

The prime contractor on this project was Northern Improvement Company. Installation of the complete edge drain system was sublet to Critical Path. The details in Appendix A show where the vegetation barriers were to be installed. Critical Path started installing the aggregate barriers on September 2, 1998. The contractor located each outlet pipe. He began to install the headwall by excavating and shaping the soil at the end of the pipe. The required area was dug out around the headwall for the aggregate. A piece of fabric was placed over the dug out area and cross-slots were cut to allow the headwall to come through. The cut slots of the fabric were tucked under the piece of fabric that was placed under the headwall. Aggregate was then placed using a loader and shovels.

No framing was done on the aggregate barriers. This process used more hand labor than methods of other contractors. The contractor did good work and was always willing to do his best. The following photos show edge drain installation.



Photo 1 - Trench for edge drain.



Photo 2 - Installing Drain.



Photo 3 - Finished aggregate barrier.

The concrete barrier locations were shaped and formed. At a few places where the drainage was coming from both directions, a double headwall was used. The headwalls were constructed for a 4:1 slope and were difficult to fit to the 6:1 slope on this project.

The contractor adjusted the headwalls to a 5:1 and made a better match with the slope. This was also done in the aggregate section. Photos 4 and 5 show the construction of the concrete barriers.



Photo 4 - Concrete Form.



Photo 5 - Finished concrete barrier.

The vegetation barriers were bid at \$350.00 each for either type. The concrete mix design for the concrete barriers and test results of concrete cylinders are located in Appendix A.

IM-2-094(016)240

Rain and excess surface moisture hindered the installation of the vegetation barriers on this project. Some of the concrete barriers were installed on October 14, 1998. Materials and Research personnel were on the project on October 15, 1998 and observed the contractor constructing forms for other concrete barriers.

The vegetation barriers were built and installed according to the plans with a few variations. These variations are noted later in this report. Plans sheets showing details and location of the vegetation barriers are located in Appendix B. Also located in Appendix B is a concrete mix design for the concrete barriers, a gradation sheet for the aggregate used in the aggregate barriers, and a certification for the geotextile fabric used under the aggregate of the aggregate barriers. Photo 6 shows the beginning of the experimental section.



Photo 6 - Overview of project.

The prime contractor for this project was Progressive Contractors Inc. (PCI) and the subcontractor for the experimental vegetation barriers was Traxler Construction Inc. The drain headwall is designed for a 4:1 slope. The contractor had to adjust each headwall to best fit the slope it was placed on. Photo 7 shows a framed barrier ready for concrete.



Photo 7 - Modified concrete barrier.



Photo 8 - Finished concrete barrier.

Photo 8 shows a finished concrete barrier and how it fits to the rest of the slope. Notice that the bottom of the barrier would be below the soil to the sides if the bottom had not been modified. This modification fits the existing grade better and shortens the contractor's time required to finish grading the soil to the barrier.

An experimental aggregate barrier is shown in Photos 9 and 10. Photo 9 shows a form that is set to the desired grade with a S2 geotextile fabric in place. The fabric should keep the aggregate separated from the soil and help to prevent weeds from growing around the headwall. The vegetation barriers, aggregate or concrete, were bid at \$350.00 each, same as in the previous project.



Photo 9 - Fabric in aggregate barrier.



Photo 10 - Finished aggregate barrier.

AC-IM-8-029(025)053

The prime contractor on this project was Northern Improvement Co. and Traxler Construction Inc. was the subcontractor for the experimental edge drains. This experimental feature was change ordered onto the project by change order 6P-6C. The project plan location and edge drain detail sheets are located in Appendix C. Also included in Appendix C is a copy of the change order, aggregate gradation for the aggregate vegetation barriers and a certification for the geotextile fabric used under the aggregate in the vegetation barriers.

The low maintenance edge drains were installed on the southbound lane on October 10, 1998. The headwalls are designed for a 4:1 slope and were adjusted to fit better with the 6:1 slope of the roadway. The concrete barrier bottom below the outlet trough was flattened to fit the grade and prevent a low spot where water can pool. The project area experienced heavy rains and the contractor had difficulty in completing this work. Photos 11, 12, and 13 show some completed barriers and site conditions.



Photo 11 - Double concrete barrier.



Photo 12 - Concrete barrier - top view.



Photo 13 - Uneven surface - aggregate barrier.

Wire mesh was used in the concrete barriers and an S2 geotextile fabric was used under the aggregate in the aggregate barriers. The vegetation barriers were change ordered onto the project reflecting in a slightly higher price per headwall. The price per headwall for this experimental project was \$387.50 each.

Evaluation

On all three projects, the concrete vegetation barriers are performing much better than the aggregate vegetation barriers. The cut vegetation will blow off of the concrete barriers easier than the aggregate barriers. A few concrete barriers have small corner cracks. One concrete barrier has severe cracks; otherwise the concrete barriers are in good shape. The concrete barriers are keeping the drains from becoming clogged with vegetation and debris.

The majority of the aggregate barriers have grass and weeds growing out of the aggregate. Vegetation growth in the aggregate barriers has increased every year since construction. Vegetation coverage in these barriers ranges from 30 percent to 80 percent. Photo 14 is an example of one such barrier. Vegetation is expected to ultimately overgrow all of the aggregate barriers.



Photo 14 – Aggregate barrier – vegetation growth.

No problems have been reported from any of the districts on mowing around or over these experimental barriers, except the Fargo District. They voiced their concerns about a potential safety issue where mowers could pick up the rock and throw it around causing a hazard to the traveling public. The Fargo District issued change order # 11p-11c to modify the rock vegetation barriers by replacing the aggregate with concrete. This change order is dated September 28, 1999 and is located with attachments in Appendix C. This work was completed in 1999 at a cost of \$845.00 each for the ten barriers. The basic cost per barrier during original construction ranged from \$350.00 to \$388.00.

There were no maintenance costs associated with maintaining the barriers. Typical photos pertaining to the three projects are shown on the next few pages. These photos are numbered 15, 16 and 17. Items that pertain to a particular project will appear under that project heading.



Photo 15 - Typical double concrete barrier.



Photo 16 - Typical single concrete barrier.



Photo 17 - Aggregate barrier overgrown with vegetation.

IM-5-094(008)071

This experimental section was last visited on October 1, 2003. At present, 20 out of 21 aggregate barriers have vegetation growing in them. Vegetation coverage in these barriers ranges from 45 percent to 90 percent. About a third of the headwalls in the aggregate barriers are 3 inches higher than the surrounding barrier. This is due to the aggregate being moved down slope or pushed into the subgrade by either mowers or other vehicles passing over it.

IM-2-094(016)240

The last evaluation for this project was completed on September 24, 2003. The vegetation growth in the aggregate barriers ranges from 15 percent to 80 percent of the area, with near 70 percent of the barriers over 50 percent coverage. All of the concrete barriers on this project are clean and in good shape except one. One concrete barrier is cracked but is still functioning satisfactorily. Photo 18 shows this cracked barrier.



Photo 18 - Cracked concrete barrier.

AC-IM-8-029(025)053

The last evaluation was conducted on September 24, 2003. Overall, the vegetation barriers are performing satisfactorily. This project no longer has any aggregate barriers. Most of the concrete barriers were clear of cut vegetation and in good condition.

Summary

The objective of this experimental feature was to determine if constructing vegetation barriers around the headwalls of edge systems would help solve the problem of vegetation and debris from blocking the drain. The vegetation barriers were designed to include an 18-inch wide band of either aggregate or concrete around the headwall. Three projects were selected for the experimental barriers. Most drains are functioning, although some aggregate barriers are partially obstructed with vegetation.

The biggest problem associated with vegetation barriers is the vegetation growing in the aggregate barriers. Vegetation is growing out of all the aggregate barriers except one. This vegetation growth ranges from 30 percent to 80 percent of the aggregate barriers. Some headwalls are higher than the surrounding aggregate due to the aggregate being moved down the slope by vehicles driving over the aggregate. The aggregate barriers contained much more cut vegetation than the concrete barriers.

The concrete barriers have a nice appearance and cut vegetation usually blows off of them. Only one cracked concrete barrier was found in the three projects. All of the aggregate barriers on project AC-IM-8-029(025)053 have been switched over to concrete barriers due to safety concerns. The reason was that mowers could pick up and cast the aggregate, posing a hazard to the traveling public.

The concrete barriers are aesthetically pleasing and are performing excellently. The concrete vegetation barriers are performing better than the aggregate vegetation barriers. There were no maintenance costs charged to any of the barriers. The aggregate and concrete vegetation barriers cost from \$350.00 to \$387.00 each.

Tables 2 and 3 show the concrete barriers performing much better than the aggregate barriers. The concrete barriers are cost effective and are providing excellent protection from vegetation growth around the headwall.

Vegetation Barriers							
Projects		Performance			Maintenance Costs	Vegetation	
		Fair	Good	Excellent		Growing in Barrier	Laying on Barrier
I-94 Mile 071	Aggregate	√			None	Yes	Yes
	Concrete			√	None	No	A few
I-94 Mile 240	Aggregate	√			None	Yes	Yes
	Concrete			√	None	No	No
I-29 Mile 053	Aggregate	N/A	N/A	N/A	N/A	N/A	N/A
	Concrete			√	None	No	No

Table 2

Vegetation Barriers		
Barrier Type	Advantages	Disadvantages
Aggregate	Easy to replace if necessary.	Aggregate moves leaving headwall high. Vegetation takes over after a few years. Mowers could toss rocks, safety hazard. Aggregate eventually needs to be removed and cleaned. Higher risk of blocking drainage with cut vegetation. Short time protection due to vegetation growth.
Concrete	Good long-term protection from vegetation growth. Provides good performance. Aesthetically pleasing. Cut vegetation readily blows off barrier. Better in keeping cut vegetation from blocking drainage.	As concrete prices increase, it may be more costly to construct. Harder to replace if necessary.

Table 3

Recommendation

It is recommended that if vegetation barriers are to be used around the edge drain headwalls, that concrete be specified. Concrete barriers provide much better long term benefits compared to vegetation barriers. A standard preformed barrier with headwall installed could be constructed to lower costs and save time.

Appendix A

SECTION	STATE	PROJECT NO.
B	ND	IM-5-094(008)071

JOB# 7

DESIGN DATA	
Traffic	Average Daily
Current 1997	Pass: 1760 Trucks 460 Total 2220
Forecast 2017	Pass: 2390 Trucks 780 Total 3170
Minimum Sight Dist. for	Design Speed 70 MPH
Stopping	600' Bridges
Full Control of Access	
No Point of Access Other Than at Interchange Ramps	

NORTH DAKOTA
DEPARTMENT OF TRANSPORTATION

FEDERAL AID PROJECT IM-5-094(008)071
RECYCLE PCC PAVEMENT (EASTBOUND)

GOVERNING SPECIFICATIONS:
Standard Specifications adopted by the North Dakota Department of Transportation October 1997.
Standard Drawings currently in effect and other Contract Provisions submitted herein.

LENGTH OF PROJECT
MILES - GROSS 8.614 mi.
MILES - NET 8.614 mi.
0.031 mi. deducted for structure

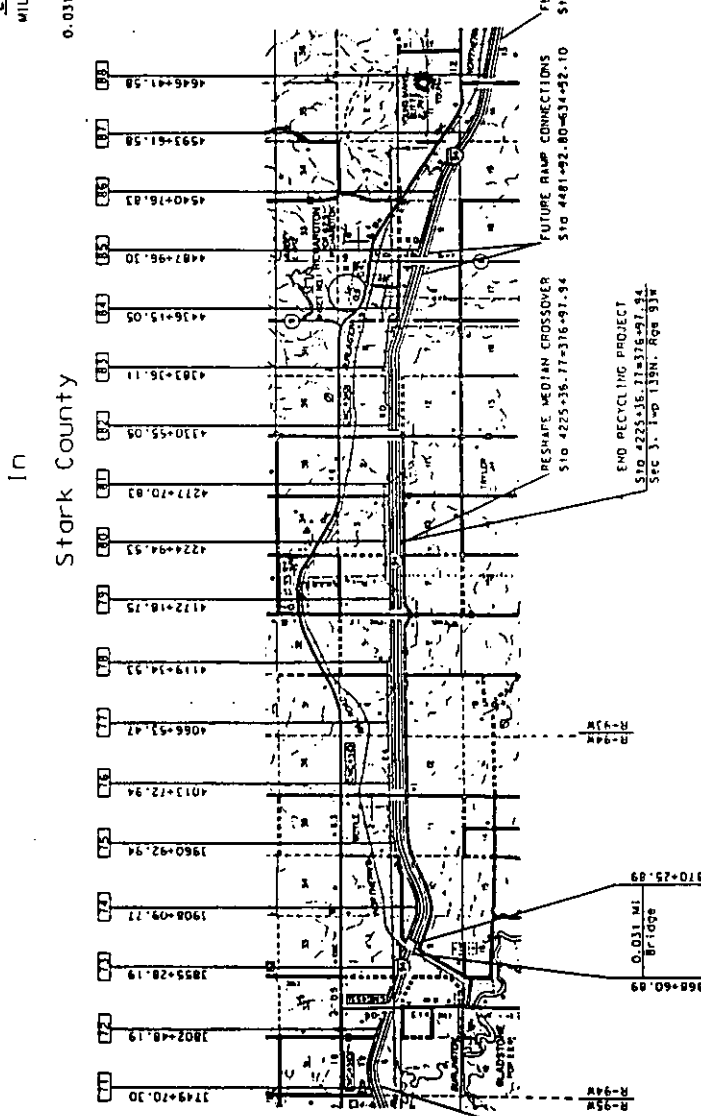

1-135N
1-135N

Stark County

0.031 MI.
BRIDGE

BEGIN RECYCLING PROJECT
S10 3755+19.42=3752+01.32
SEC 6, 1st 135N, R04 S14

END RECYCLING PROJECT
S10 4225+35.77=3756+97.34
SEC 3, 1st 135N, R04 S14

FRESHALE MEDIAN CROSSOVER
S10 4225+35.77=3756+97.34

FUTURE RAMP CONNECTIONS
S10 4481+92.80=634+52.10

FUTURE MEDIAN CROSSOVER
S10 4679+20.46=649+00.08

U.S. DEPARTMENT OF TRANSPORTATION
FEDERAL HIGHWAY ADMINISTRATION

APPROVED

DIVISION ADMINISTRATOR _____ DATE _____

APPROVED DATE 12-31-97
P.E. 1199
DIRECTOR OF HIGHWAYS AND ENGINEERING
NORTH DAKOTA DEPARTMENT OF TRANSPORTATION

DESIGNER *Brian Bean*
DESIGNER *Douglas A. Schumann*
DESIGNER _____
RECOMMEND APPROVAL 12-31-1997
DESIGN ENGINEER *[Signature]*

STATE	PROJECT NO.	SHEET NO.
ND	IM-5-0941008 1071	3

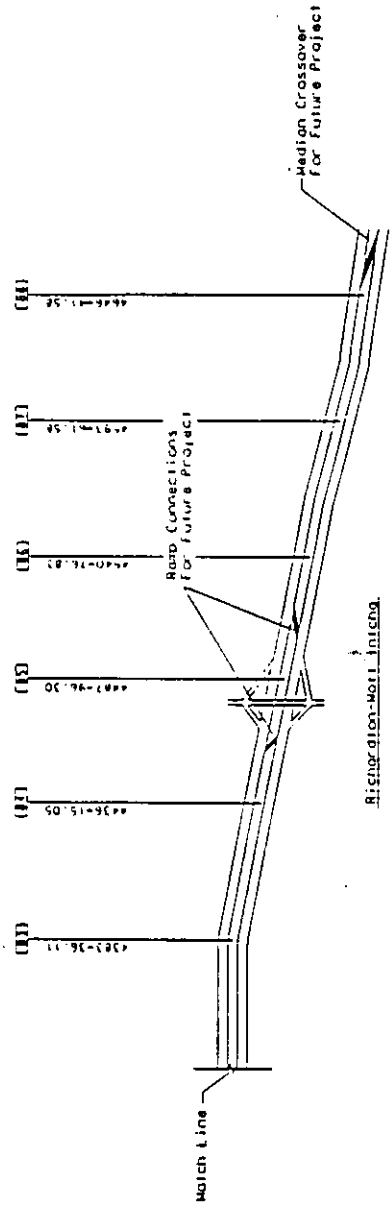
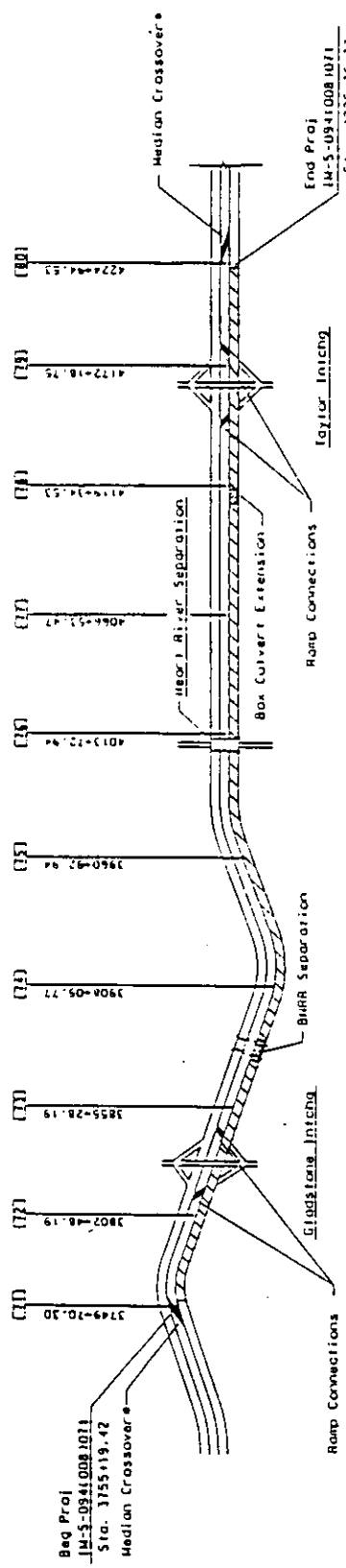
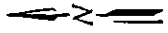

SCOPE OF WORK
 Gladstone E. to Taylor
 Interchange - EB
 Recycled PCC Pvmnt.
 scope.dgn

NOTE: Traffic control for median crossovers and ramp connections shall follow Standard D-104-15.

- PCC Recycling
 - Structural Improvements
- to be reshaped for a future project (after traffic has been returned to normal operation)

SECTION	STATE	PROJECT NO.	SHEET NO.
B	MD	1M-5-09410081071	22

NOTE: From Sta 4013+12 to Sta 4066+53 Vegetation Barriers shall be installed around the right-of-ways of the edge drains as shown on the following sheets.

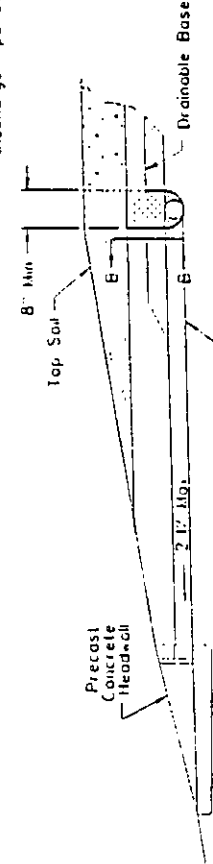
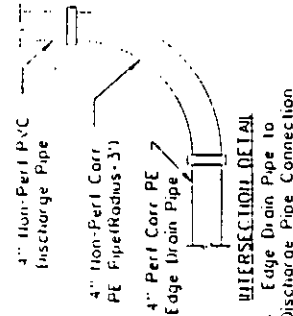
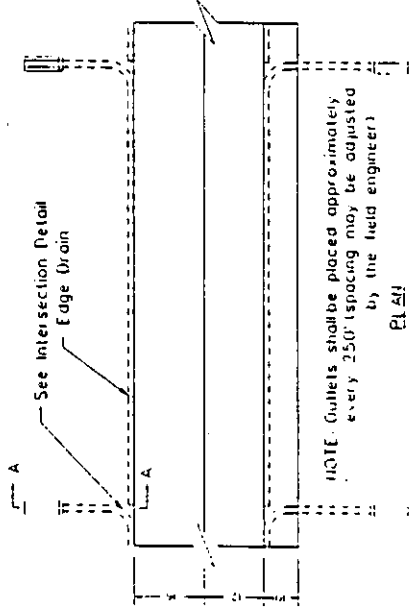
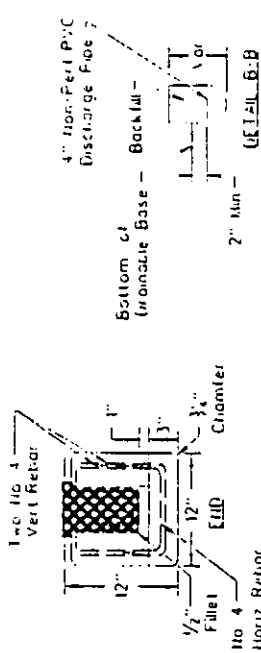
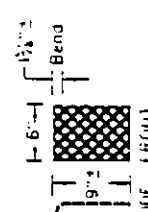
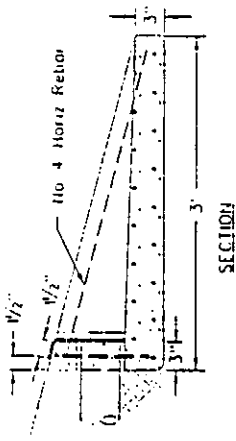
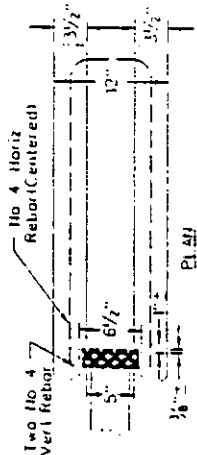
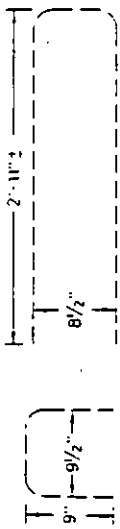

RODENT SCREEN: The rodent screen shall be fabricated from flattened expanded metal with screen openings of approximately 0.25 square inches. The screen shall be 16 ga. metal and be hot dip galvanized after fabrication

EDGE DRAIN TRENCH: The distance between the bottom of the drainable base and the top of the edge drain pipe will be 2 inches minimum.

EDGE DRAIN DISCHARGE PIPE AND SPLASH BLOCK DETAILS

Cladstone E. to Taylor Interchange - EB

Recycled PCC Pavement

STATE	PROJECT NO.	SHEET
ND	14-5-09410081071	23
8		

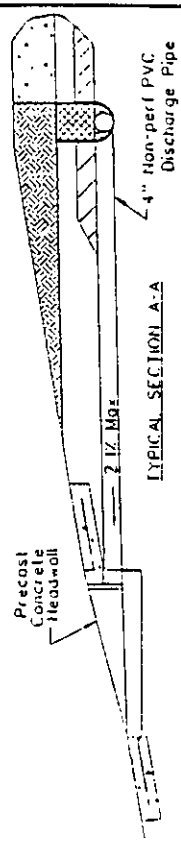
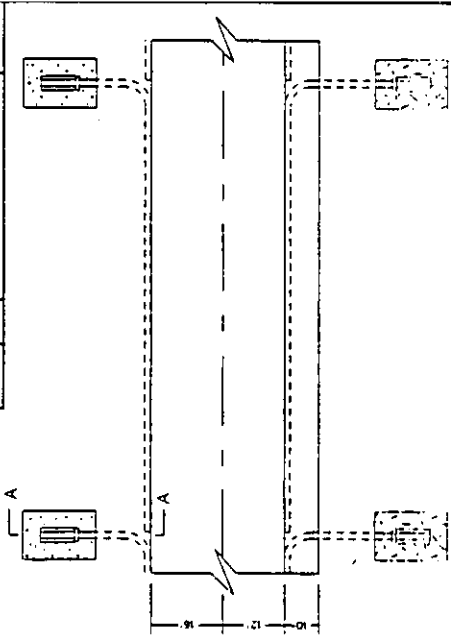

VEGETATION BARRIER AROUND HEADWALLS OF EDGE DRAINS
 CONCRETE
 MEDIAN DRAINS - TYPE C -
 GLADSTONE EAST TO TAYLOR INTERCHANGE - EAST BOUND
 RECYCLED P.C.C. PAVEMENT

NOTE 1: Concrete Vegetation Barriers shall be placed around the headwalls of the edge drains from sta 4013+12 to sta 4039+82.5 right and from sta 4039+82.5 to sta 4066+53 left.

NOTE 2: MEASUREMENT AND PAYMENT (MEDIAN DRAINS-TYPE C): The concrete shall be cast in place around the splashblock. The concrete and wire fabric shall not be measured for payment. The unit price bid for "Median Drains-Type C" shall include all costs to supply, prepare, form, and place the wire fabric and concrete.

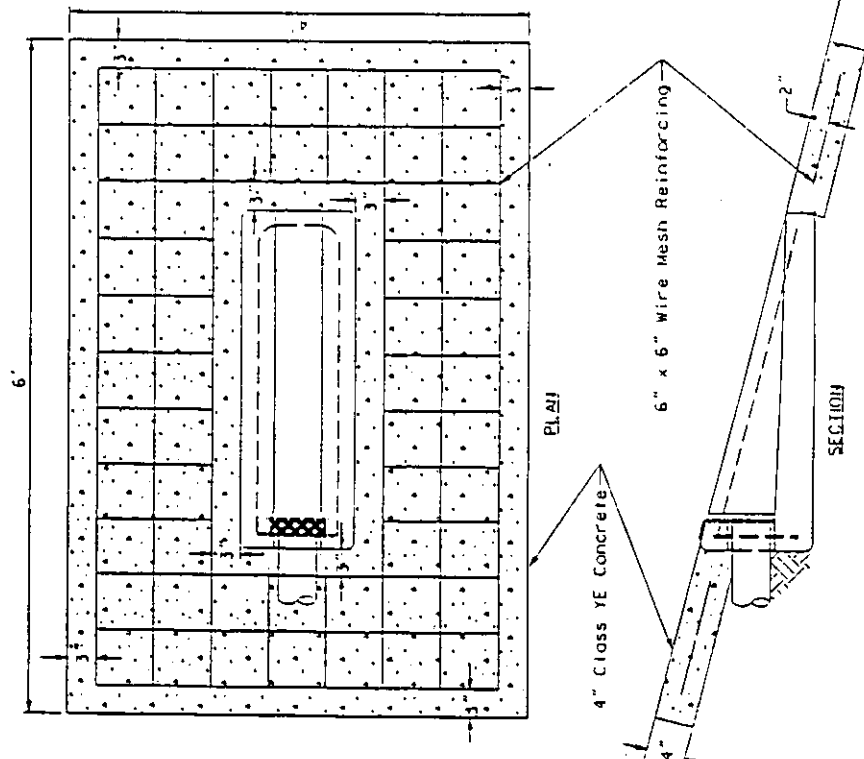

... 10 paring/cadage.dwg Jan. 06. 1990 10:44:43

SECTION	STATE	PROJECT NO.	SHEET
B	ND	14-5-09410081071	24

NOTE 1: Aggregate and Separation Fabric Vegetation Barrier shall be placed around the headwalls of edge drains from sta 4013+12 to sta 4039+82.5 left and from sta 4035+82.5 to sta 4066+53 right.

NOTE 2: MEASUREMENT AND PAYMENT MEDIAN DRAINS-TYPE A1: The S2 Geotextile fabric shall be placed under the aggregate barrier and the splashblock. The fabric and the aggregate shall not be measured for payment. The unit price bid for "Median Drains-Type A" shall include all costs to supply and place the fabric and aggregate.

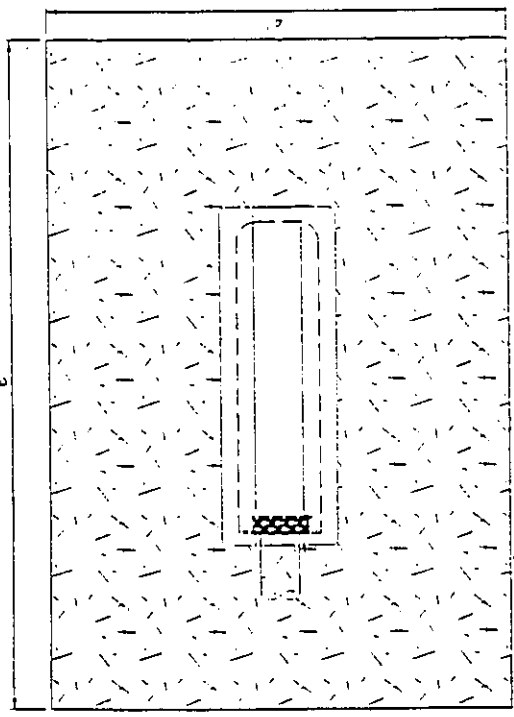

AGGREGATE BARRIER GRADATION

SIEVE SIZE	PERCENT PASSING
3"	100
2 1/2"	90-100
3/4"	0-5

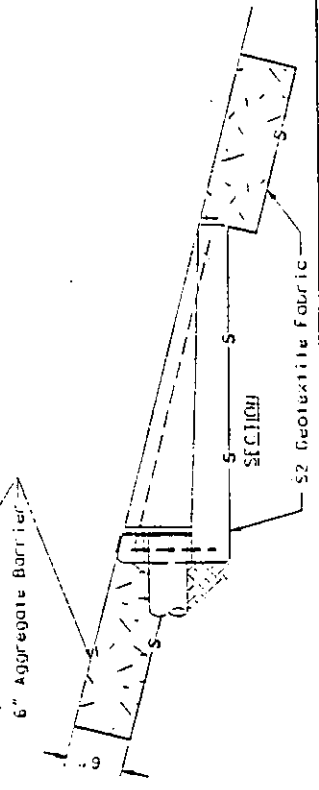
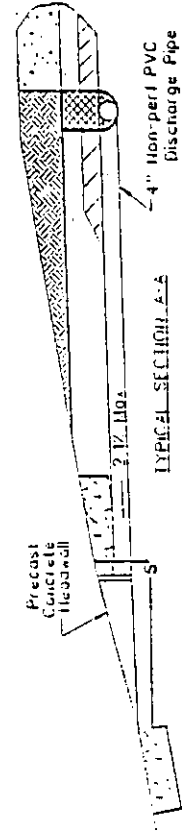
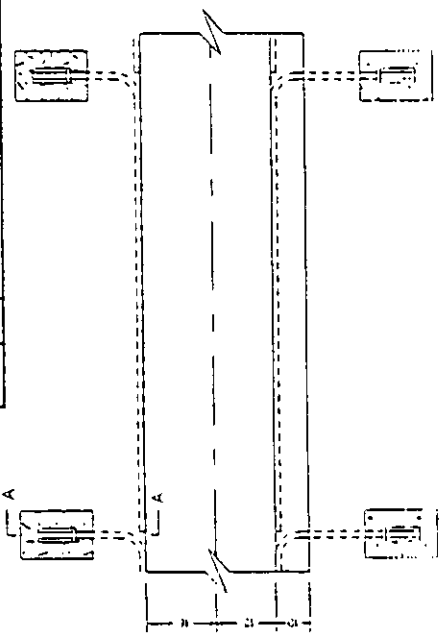

VEGETATION BARRIER AROUND HEADWALLS OF EDGE DRAINS
 AGGREGATE & SEPARATION FABRIC - MEDIAN DRAINS - TYPE A - GLADSTONE E TO TAYLOR INTERCHANGE - EAST BOUND
 RECYCLED P.C.C. PAVEMENT

Distribution: Project File
 District File

North Dakota Department of Transportation
 CONCRETE PROPORTION DESIGN

PROJECT: IM-5-094(008)071 CONTRACTOR: NORTHERN IMPROVEMENT CO.
 TYPE OF WORK: BOX CULVERT EXTENSION

DESIGN NO.: 1 DATE: 05/04/98 CLASS OF CONCRETE: AE 3

TYPE & BRAND OF CEMENT: DAKOTA TYPE 3

SOURCES: Cement S. DAK. ; Sand FISHER ; Rock GLENDIVE

SPECIFIC GRAVITIES:
 Gc= 3.15 (Cement); Gfa= 2.62 (Flyash); Gs= 2.63 (Sand); Gr= 2.64 (Rock)*
 *(Combine if two rock sizes)

PERCENT OF TOTAL AGGREGATE (by weight):
 S= 45% Sand; Ra= 55 % Size Rock; Rb= 0 % Size Rock

CALCULATIONS: (for 27 C.F. Batch Size)

PROPORTIONS		LBS/BATCH		C.F.
CEMENT:	(14lbs/Sack) x (5.0 Sacks/C.Y.) x (27 /27) Adjusted to 5.1 Sacks/C.Y. for Flyash	479.40	C=	2.44
FLYASH:	20 % Flyash used	112.80	FA=	0.69
WATER:	(4.5 Gal/Sack) x (3.33) x 5.1 Sacks Cement/C.Y. (includes free moisture in aggregates & flyash if any)	236.16	W=	3.78
AIR:	5 % assumed entrained air in mix	XXXXXXX	A=	1.62
Dry Wt., T= 3036.92		Absolute Volume, V, of Total Aggregate	V=	13.47
		Combined Specific Gravity of Total Aggregate	Gsr=	2.64
SAND, Dry Wt.		1366.61	S=	8.33
ROCK, Size . Dry Wt.		1670.31	R=	10.14
ROCK, Size . Dry Wt.		0		
TOTAL WEIGHT PER BATCH		3865.28	BATCH SIZE =	27.00

CALCULATED UNIT WEIGHT = 143.16 lbs/C.F.

 Engineer



MIDWEST TESTING LABORATORY

1463 West Villard \ PO Box 467 \ Dickinson, ND 58602
Phone (701) 227-8701 \ Fax (701) 227-4460



REPORT OF: TESTS OF CONCRETE CYLINDERS

PROJECT: IM-5-094 (008) 071
Stark County, North Dakota

DATE: July 6, 1998
July 27, 1998

REPORTED TO: North Dakota Department of Transportation
Drawer G
Dickinson, ND 58602

COPIES: Northern Improvement Co
Taylor
Dickinson Ready Mix

PROJECT NO: D1294

GENERAL DATA

CYLINDER NUMBER	10A	10B	10C	10D
DATE CAST	6-26-98			
CAST BY	North Dakota Department of Transportation			
CONCRETE TEMPERATURE (°F)	80			
SLUMP (")	Not Given			
AIR CONTENT (%)	5.5			
UNIT WEIGHT (pcf)	Not Tested			
SPECIFIED STRENGTH (At 28 days)	3000 psi			
LOCATION	Box culvert			

MIX PROPORTIONS

CEMENT (Lbs)	94
FLY ASH (Lbs)	19
FINE AGGREGATE (Lbs)	217
COARSE AGGREGATE (Lbs)	313
ADMIXTURE	
CONCRETE FURNISHED BY	Dickinson Ready

COMPRESSIVE STRENGTH DATA (Standard 6" x 12" Cylinder)

LABORATORY NUMBER	6292-1	6292-2	6292-3	6292-4
DAYS JOB CURED	1	1	1	1
DAYS LABORATORY CURED	6	6	27	27
AGE OF TESTS (Days)	7	7	28	28
LOAD AT FAILURE (Lbs)	86,000	85,500	121,000	110,000
STRENGTH (PSI)	3040	3020	4270	3890

REMARKS

SIGNED Mike Beiler

Appendix B

HTA STATE	PROJECT NO.	SHEET NO.
8 ND	14-2-09410161240	4

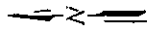

Usvegq Interchange south ramps
will be closed during construction.

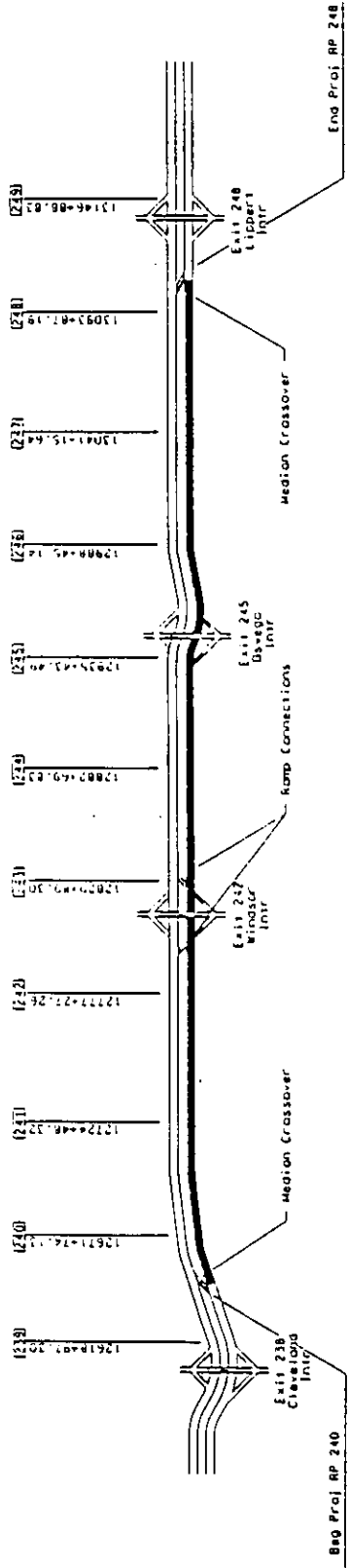

REMARKS The existing crossmatched temporary connections shall be removed at the end of the project.

SCOPE OF WORK
Cleveland E to Libbert

STATE	PROJECT NO.	SHEET
B	IM-2-09410161240	26

NOTE: From S10 12829+83 to S10 12822+70 vegetation barriers shall be installed around the headwalls of the edge drains as shown on the following sheets.

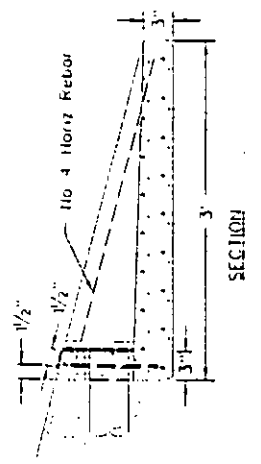
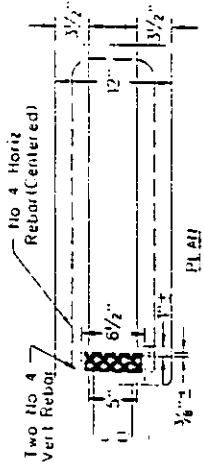
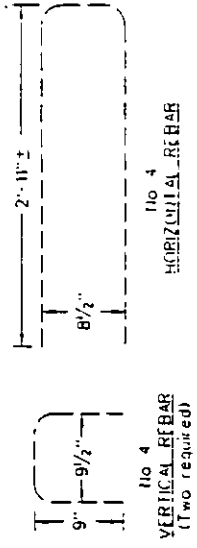

RODENT SCREEN: The rodent screen shall be fabricated from flattened expanded metal with screen openings of approximately 0.25 square inches. The screen shall be 16 ga. metal and be hot dip galvanized after fabrication.

EDGE DRAIN TRENCH: The distance between the bottom of the drainable base and the top of the edge drain pipe will be 2 inches minimum.

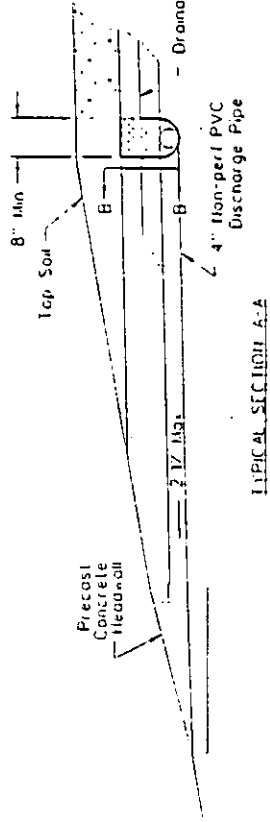
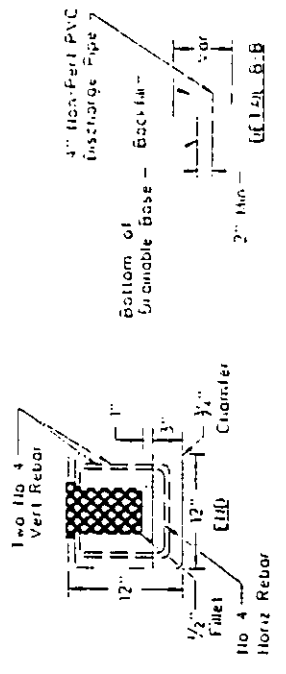
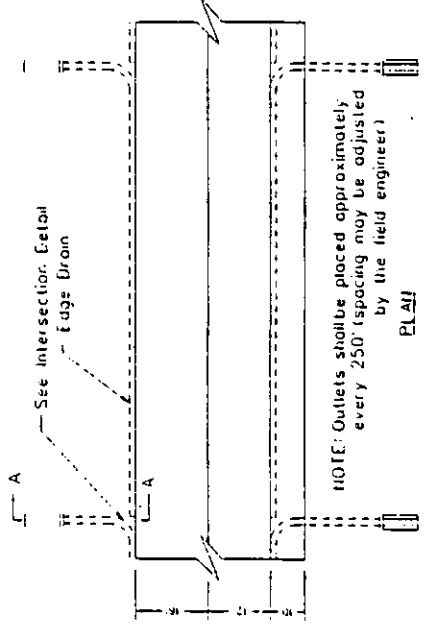

EDGE DRAIN DISCHARGE PIPE AND
SPLASH BLOCK DETAILS

Cleveland to Lipper (E Bd)

Recycled PCC Pavement

REGION	STATE	PROJECT NO.	SHEET NO.
B	ND	114-2-09410161240	27

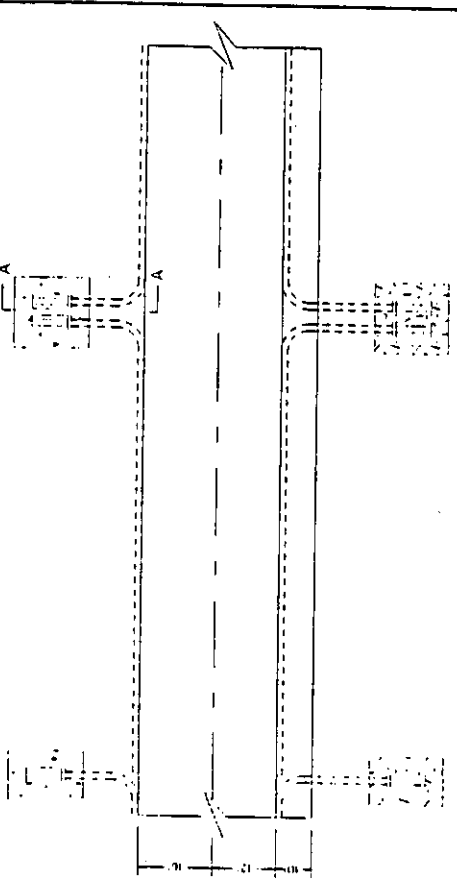

NOTE 1: Concrete Vegetation Barriers shall be placed around the headwalls of the edge drains from sta 12829+89 to sta 12856+29.5 right and from sta 12856+29.5 to sta 12882+70 left.

NOTE 2: MEASUREMENT AND PAYMENT (MEDIAN DRAINS-TYPE C): The concrete shall be cast in place around the spiroblock the concrete and wire fabric shall not be required for payment. The unit price bid for "Median Drains-Type C" shall include all costs to supply, prepare, form, and place the wire fabric and concrete for each Concrete Headwall.

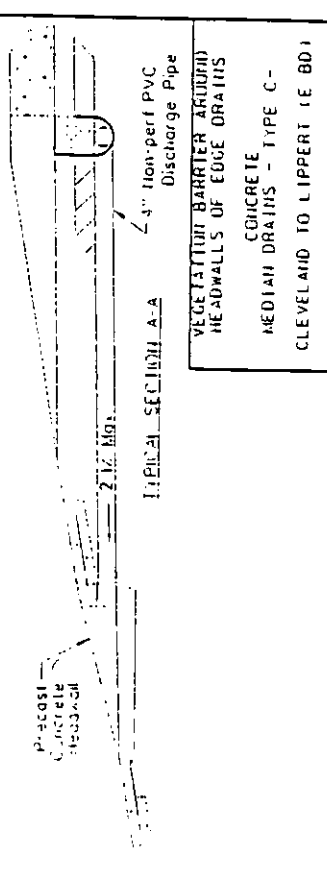

VEGETATION BARRIER ARMOR
HEADWALLS OF EDGE DRAINS
CONCRETE
MEDIAN DRAINS - TYPE C -
CLEVELAND TO LIPPERT (E BD)

RECYCLED PCC PAYMENT 60324

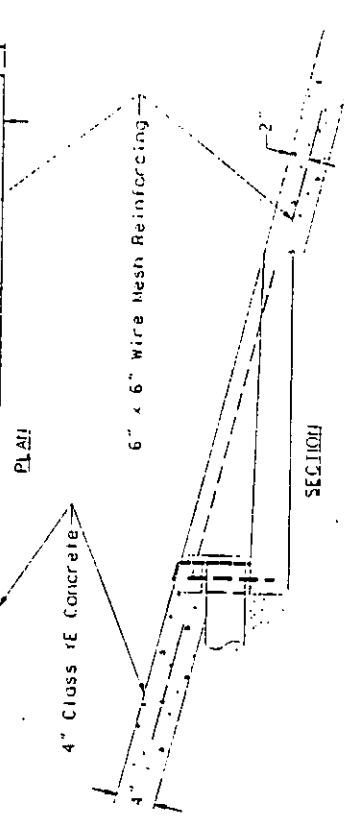
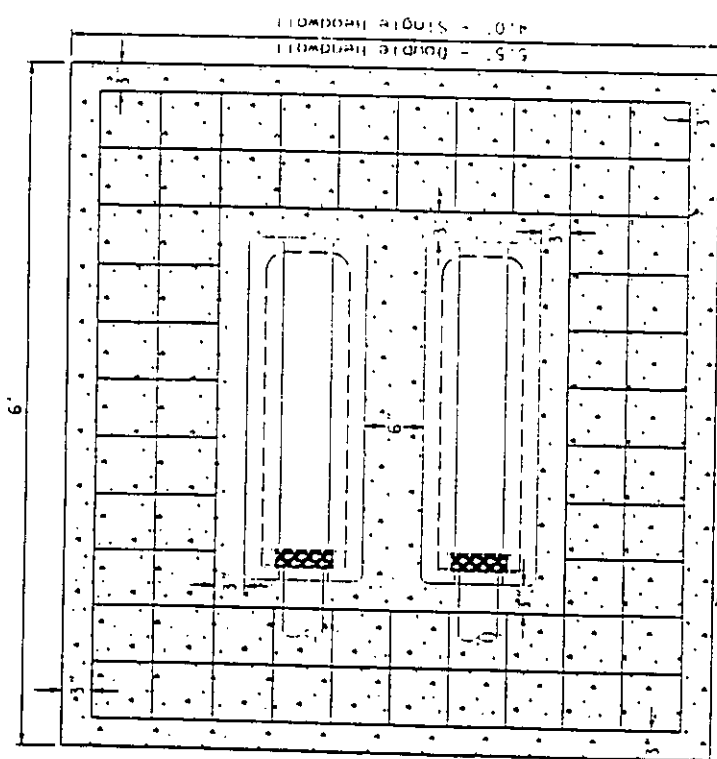

STATE	PROJECT NO.	SHEET
ND	14-2-0910161240	2B

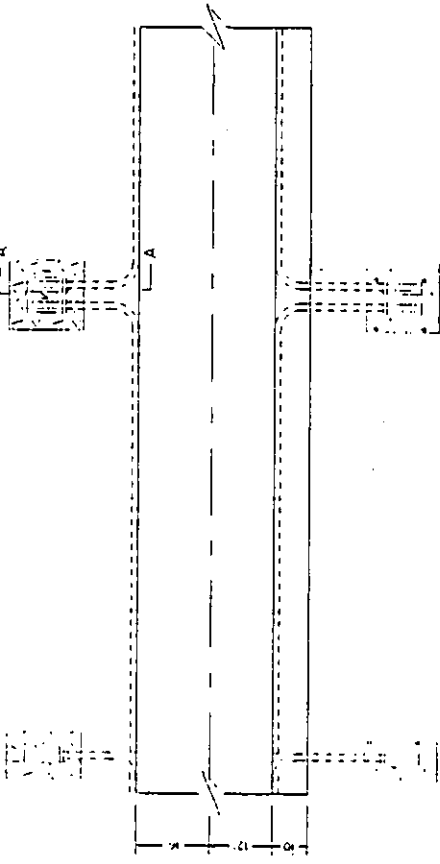

NOTE 1: Aggregate and Separation Fabric Vegetation Barrier shall be placed around the headwalls of edge drains from Sta 12823+89 to Sta 12856+29.5 left and from Sta 12856+29.5 to Sta 12882+10 right.

NOTE 2: MEASUREMENT AND PAYMENT MEDIAN DRAINS-TYPE A: The S2 Geotextile fabric shall be placed under the aggregate barrier and the splashblock. The fabric and the aggregate shall not be measured for payment. The unit price bid for "Median Drains-Type A" shall include all costs to supply and place the fabric and aggregate for each Concrete Headwall.

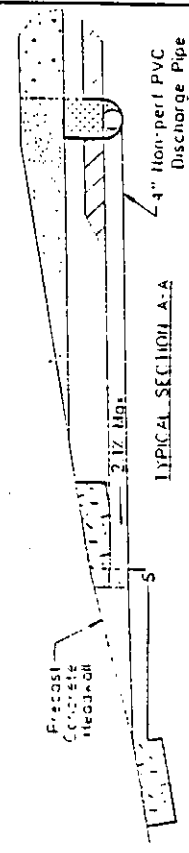

VEGETATION BARRIER AROUND HEADWALLS OF EDGE DRAINS
 AGGREGATE & SEPARATION FABRIC - MEDIAN DRAINS - TYPE A - CLEVELAND TO LIPPERT (E BD)
 RECYCLED PCC PAVEMENT

AGGREGATE BARRIER GRAVATION	PERCENT PASSING
3"	100
2 1/2"	90-100
3/4"	0-5

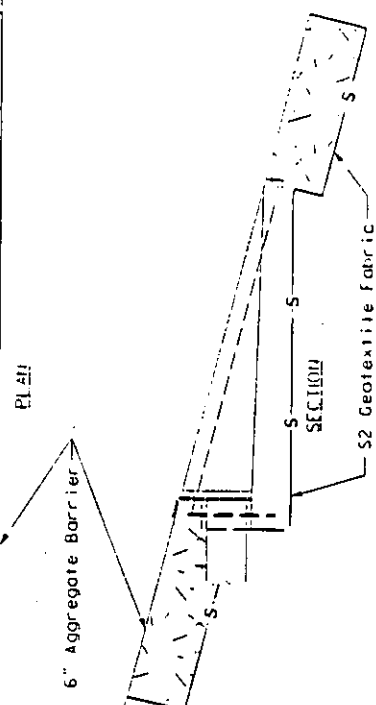
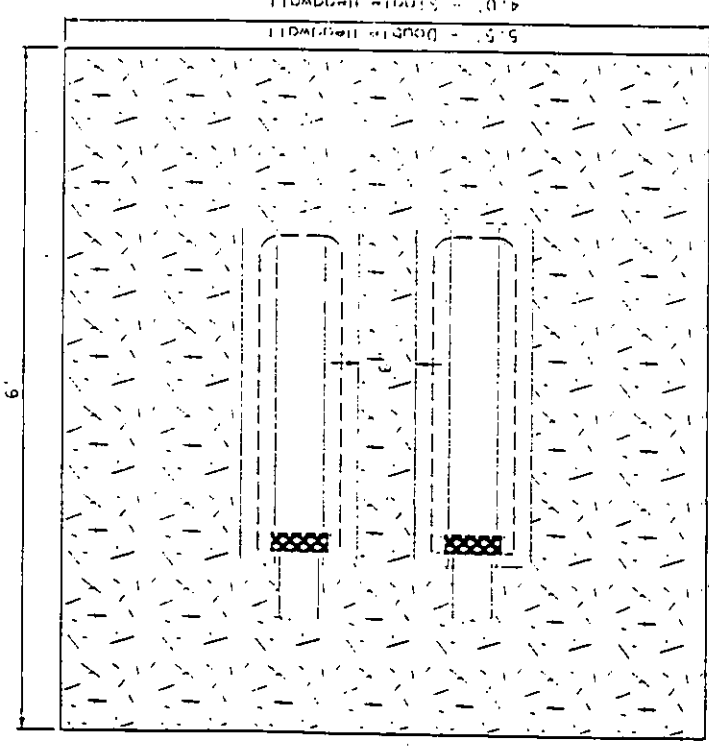



711 Nonwoven Geotextile

711 is a polypropylene; staple fiber, needlepunched nonwoven geotextile manufactured at one of Synthetic Industries' facilities that has achieved ISO-9002 certification for its systematic approach to quality. The fibers are needled to form a stable network that retain dimensional stability relative to each other. The geotextile is resistant to ultraviolet degradation and to biological and chemical environments normally found in soils. Synthetic Industries 711 conforms to the property values listed below:

<u>PROPERTY</u>	<u>TEST METHOD</u>	<u>MINIMUM AVERAGE ROLL VALUES¹</u>	
		<u>English</u>	<u>Metric</u>
<u>Mechanical</u>			
Grab Tensile Strength	ASTM D4632	180 lbs	800 N
Puncture Strength	ASTM D4833	75 lbs	330 N
Trapezoidal Tear	ASTM D4533	50 lbs	220 N
<u>Hydraulic</u>			
Apparent Opening Size (AOS)	ASTM D4751	100 US Std. Sieve	0.150 mm
Permittivity, ψ	ASTM D4491	.05 sec ⁻¹	.05 sec ⁻¹
<u>Endurance</u>			
UV Resistance (% retained @ 500 hours)	ASTM D4355	70 %	70 %

Notes:

Values shown are in weaker principal direction. Minimum average roll values represent a 95 percent confidence level, calculated as the mean minus two standard deviations.

Standard Roll Size: 12.5' x 300' = 417.0 sq. yds.

15.0' x 300' = 500 sq. yds.

Product # 98 N 72
Lot # 4031626A180-5029025A180
Northern Water Works Supply Inc.

Seller makes no warranty, express or implied, concerning the product furnished hereunder other than it shall be of the quality and specifications stated herein. ANY IMPLIED WARRANTY OF FITNESS FOR A PARTICULAR PURPOSE IS EXPRESSLY EXCLUDED AND TO THE EXTENT THAT IT IS CONTRARY TO THE FOREGOING SENTENCE, ANY IMPLIED WARRANTY OF MERCHANTABILITY IS EXPRESSLY EXCLUDED. Any recommendations made by Seller concerning uses or applications of said product are believed reliable and Seller makes no warranty of results to be obtained.

This Data Sheet supersedes all previous Data Sheets for this style and is subject to change without notice.

NW711-1-4.11.95

Distribution: Project File
District File

North Dakota Department of Transportation
CONCRETE PROPORTION DESIGN

PROJECT: IM-2-094(016)240
TYPE OF WORK: JERSEY BARRIER

CONTRACTOR: PCI

DESIGN NO.: 1 DATE: 09/22/98 CLASS OF CONCRETE: AE-3 *for structures & Draining*

TYPE & BRAND OF CEMENT: LAFARGE TYPE I

SOURCES: Cement LAFARGE ; Sand CAMAS ; Rock CAMAS

SPECIFIC GRAVITIES:

Gc= 3.140(Cement); Gfa= 0.00 (Flyash); Gs= 2.650(Sand); Gr= 2.670(Rock)*

*(Combine if two rock sizes)

PERCENT OF TOTAL AGGREGATE (by weight):

S= 35% Sand; Ra= 65 % Size 3 Rock; Rb= 0 % Size Rock

CALCULATIONS: (for 27 C.F. Batch Size)

	PROPORTIONS	LBS/BATCH		C.F.
CEMENT:	(94lbs/Sack) x (5.000 Sacks/C.Y.) x (27 / 27) Adjusted to 9.000 Sacks/C.Y. for Flyash	= 564	C=	2.378
FLYASH:	0 % Flyash used	0	FA=	0
WATER:	(5.0 Gal/Sack) x (3.33) x 5.000 Sacks Cement/C.Y. (includes free moisture in aggregates & flyash if any)	= 249.900	W=	4.005
AIR:	6.500 % (assumed entrained air in mix)	XXXXXX	A=	1.755
Dry Wt., T=	3051.186	Absolute Volume, V, of Total Aggregate	V=	18.362
		Combined Specific Gravity of Total Aggregate	Gsr=	2.663
SAND, Dry Wt.	=	1067.915	S=	6.458
ROCK, Size 3, Dry Wt.	=	1983.271	R=	11.904
ROCK, Size , Dry Wt.	=	0		
TOTAL WEIGHT PER BATCH		= 3865.086	BATCH SIZE =	27.000

CALCULATED UNIT WEIGHT = 143.150 lbs/C.F.

Lucas Olson
Engineer

Appendix C

STATE PROJECT NO. ND AC-1M-8-02810251053

JOB# 3

DESIGN DATA			
Traffic	1981	1987	1993
Current	1981	1987	1993
Forecast	1981	1987	1993
Minimum Sight Dist. for Stopping	415'	415'	415'
Full Control of Access			
No Point of Access Other than of Interchange Ramps			

NORTH DAKOTA
DEPARTMENT OF TRANSPORTATION

FEDERAL AID PROJECT AC-1M-8-02810251053

PC PAVEMENT (S BOUND ROW) GRADING & SURFACING OF MEDIAN CROSSOVER AND RAMP CONNECTIONS

in Cass County

CONVENTIONAL SPECIFICATIONS:

Standard Specifications adopted by the North Dakota Department of Transportation October 1987; Standard Drawings currently in effect; and other Contract Provisions submitted herein.

LENGTH OF PROJECT

MILES CROSS 1.384
MILES NET 1.310

0.043 MI Deducted for Structures

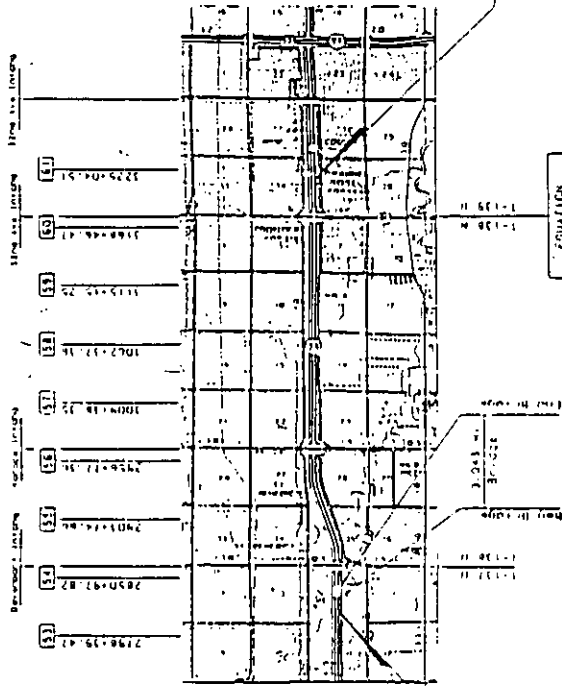

Sec Proj. 2838-56
Sec 2, T-10 137' N. Rge 19 E

Sec 15, T-10 135' N. Rge 19 E

DESIGNER *[Signature]*
DESIGNER *[Signature]*
DESIGNER *[Signature]*
RECOMMEND APPROVAL Sept 11, 19 97
DESIGN ENGINEER *[Signature]*

U.S. DEPARTMENT OF TRANSPORTATION
FEDERAL HIGHWAY ADMINISTRATION
APPROVED
DIVISION ADMINISTRATOR DATE

APPROVED DATE 9-11-97
[Signature]
P.E. 1199
DIRECTOR OF HIGHWAYS AND ENGINEERING
NORTH DAKOTA DEPARTMENT OF TRANSPORTATION

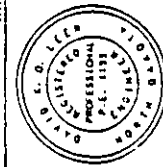

All steel bars used for the depicted construction joints on this project shall be fully tested and comply to ASTM A615 Type B.
 (1) - Bar thickness thickness of the PCC pavement.
 1 - Pavement Depth
 retain reinforcement for top 1" only. Section shown of 20" but may be increased to 24" long. Construction joints shall not be tested from 510 1022-40 to 1022-40.

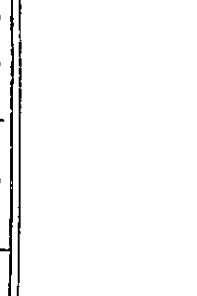
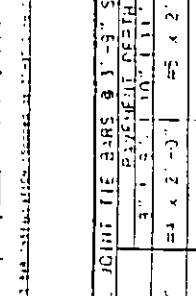
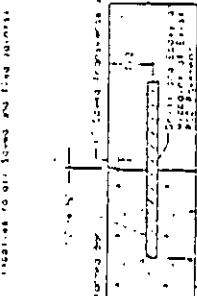
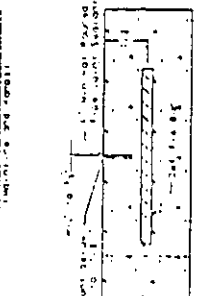
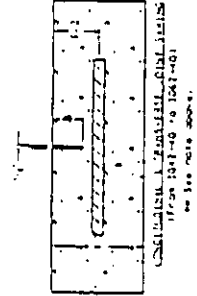

CONSTRUCTION JOINT TIE BARS @ 3'-5" SPACING	
SECTION	DEPTH
10' x 2'-0"	11' x 1'-12"
10' x 2'-0"	11' x 2'-5"
10' x 2'-0"	11' x 3'-0"

PCC JOINT DETAILS
 Wild Rice River to 1 Mile S. of 2002-40 South Fargo, ND
 8/1/88

SECTION	STATE	PROJECT NO.	DATE
9	ND	IM-8-029(025)053	35

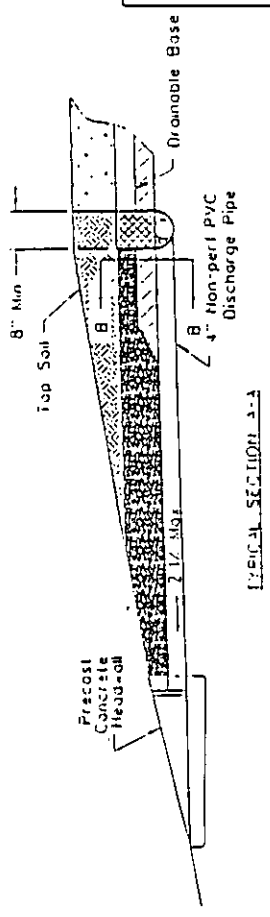
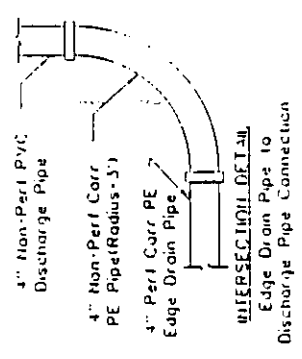
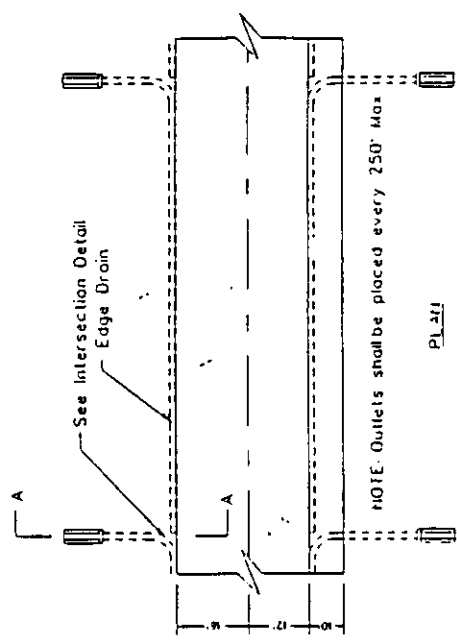
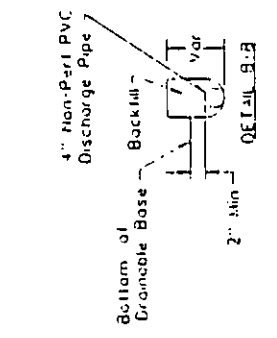
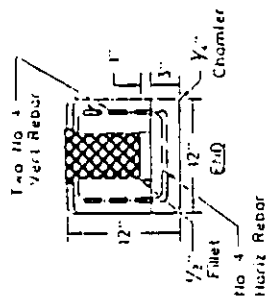
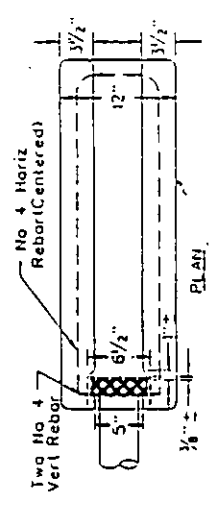
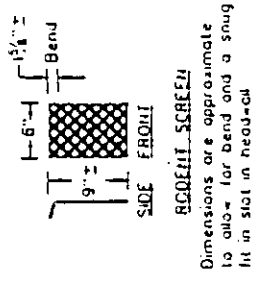
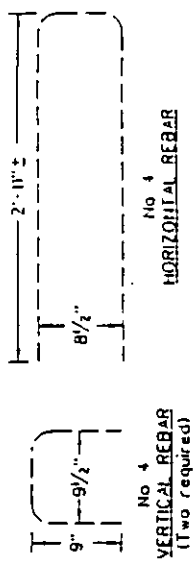

RODENT SCREEN: The rodent screen shall be fabricated from flattened expanded metal with screen openings of approximately 0.25 square inches. The screen shall be 16 ga. metal and be hot dip galvanized after fabrication.

EDGE DRAIN TRENCH: The distance between the bottom of the drainable base and the top of the edge drain pipe shall be 2 inches minimum.

EDGE DRAIN DISCHARGE PIPE AND SPLASH BLOCK DETAILS



July 29, 1998

Amoco Fabrics and Fibers Company

Suite 550
900 Circle 75 Parkway
Atlanta, Georgia 30339
(770) 360-3025

Brock White Company
2575 Kasota Avenue
Saint Paul, MN 55108

Job Reference:

B/L # 38657
Shipper # 401835

Amoco Fabrics and Fibers Company hereby certifies that CEF Style 4552 shipped to you on July 28, 1998, on AFFC order # SP51352, meets the following minimum average roll values:

Property	Test Method	Minimum Average Roll Value (English)	Minimum Average Roll Value (Metric)
Grab Tensile	ASTM-D-4632	180 lb	.300 kN
Grab Elongation	ASTM-D-4632	50 %	50 %
Mullen Burst	ASTM-D-3786	350 psi	2410 kPa
Puncture	ASTM-D-4833	105 lb	.465 kN
Trapezoidal Tear	ASTM-D-4533	75 lb	.330 kN
UV Resistance	ASTM-D-4355	70 % at 500 hr	70 % at 500 hr
AOB	ASTM-D-4751	100 micr	0.159 mm
Permeability	ASTM-D-4491	1.5 sec ²	1.5 sec ²
Permeability	ASTM-D-4491	105 gal/min/ft ²	4275 L/min/m ²

Amoco Fabrics and Fibers Company manufactures all the nonwoven geotextile fabric certified above. The values are a result of testing conducted in on-site laboratories at the time of production. All test methods used are ASTM or industry standards. Test data is retained in the Quality Control files at Amoco's production facility.

William L. Music
William L. Music
Quality Assurance Manager
Amoco Fabrics and Fibers Company

mm



CONCRETE, SAND, AND GRAVEL WORKSHEET
 Department of Transportation, Materials & Research
 SFN 2453 (Rev. 3-95)

PROJECT: **1M-2-029 025053** COUNTY: **Cass**
 ATTENDED BY: **Carlstrom** DATE RECEIVED: **10-13-98**

Vegetation Barrier Aggregate

LOCATION: _____
 FROM: _____
 SAMPLED: _____ FIELD SAMPLE NO.: _____
 NO.: _____ SIZE NO.: _____
 Shrink % Loss - _____
 to Gravelly - _____
 description - _____
 Losses (Grad.) % Loss - _____
 added Lubr. (Kg/m³) - _____

(mm)	Ret.	Wt. Ret.		% Ret.	% Pass	ND Spec.
		Non-Cum.	Cum.			
100	4"					
90	3 1/2"					
75	3"	0	0	0	100	100
63	2 1/2"	0	0	0	100	100
50	2"	0	0	0	100	
37.5	1 1/2"	0	0.1760	1.15	98.85	
25.0	1"	7.9350	8.1110	53.12	46.88	
19.0	3/4"	6.3085	14.4195	94.43	5.57	0-5
18.0	3/8"	0.8500	15.2695	99.99		
12.5	1/2"					
9.5	3/8"					
4.75	No. 4					
2.36	No. 8					
Minus No. 8						
Wt. Check						
Original Wt.		15.27				
Fineness Modulus						

LOCATION: _____
 FROM: _____
 SAMPLED: _____ FIELD SAMPLE NO.: _____
 NO.: _____
 Shrink % Loss - _____
 to Gravelly - _____
 description - _____
 Losses (Grad.) % Loss - _____
 added Lubr. (Kg/m³) - _____

(mm)	Ret.	Wt. Ret.		% Ret.	% Pass	ND Spec.
		Non-Cum.	Cum.			
9.5	3/8"					
4.75	No. 4					
2.36	No. 8					
2.00	No. 10					
1.18	No. 16					
600um	No. 30					
425um	No. 40					
300um	No. 50					
150um	No. 100					
75um	No. 200					
Minus No. 200 (75um)						
Original Wt.						
Wt. After Wash						
Wash Loss						
Wt. Check						
Fineness Modulus						

District _____
 Central Lab. _____

*Attention Advised

C-5 _____
 AUTHORIZED SIGNATURE

NORTH DAKOTA DEPARTMENT OF TRANSPORTATION
CHANGE ORDER

SFN 11570

SHEET 1

CHANGE: 6P
ORDER NO: 6C

PROJECT: AC-IM-8-029(025)053
COUNTY: CASS COUNTY
FOR: PCC PAVEMENT & MEDIAN CROSSEOVERS

CONTRACTOR: NORTHERN IMPROVEMENT CO
PO BOX 2846
FARGO, ND 58102

ORIGINAL CONTRACT AMOUNT
\$ 7,143,747.10

DATE: 11/18/1998

SPCC CODE NO NO	ITEM OF WORK	UNIT	ORIG + CR - PREVIOUS CHG QUANTITY	OR - QUANTITY	UNIT PRICE	INCREASE AMOUNT	DECREASE AMOUNT	
ADDED CONTRACT ITEM								
PARTICIPATING (IN FEDERAL FUNDS)								
714	1 HEADWALL VEGETATION BARRIERS	L SUM	0.000	1.000	15,500.000	15,500.00		
NET INCREASE OR DECREASE TO DATE			42,796.34	PART	0.00 NON-PART	TOTALS	15,500.00	0.00
						NON-PARTICIPATING	0.00	0.00
						PARTICIPATING	15,500.00	0.00

61,149.34

DUZ TO THIS CHANGE, THE CONTRACT TIME:
MAY BE REVISED IF THE WORK AFFECTS/AFFECTED THE CONTROLLING OPERATION.

EXPLANATION OF CHANGE IN PLAN RECOMMENDED

If the Federal Funds authorized in the cost participation agreement with the local agency is exceeded and Federal Funds are not available for this change, the local agency will assume the total cost of this change order.

SEE ATTACHED SHEETS.

CONTRACTOR DATE

() Approval Recommended () Approved
PROJECT ENGINEER DATE

CITY/COUNTY/OTHER OFFICIAL DATE

() Approval Recommended () Approved
DISTRICT ENGINEER DATE

REPRESENTING

() Approved
REGION ENGINEER DATE

PROJECT IM-8-029(025)053

CHANGE ORDER 6P-6C

HEADWALLS VEGETATION BARRIERS

The North Dakota Department of Transportation Materials and Research Division requested the Fargo District to add this experimental feature added to this project. The location of this test section is from mile 58 to mile 59. See attached sheets for additional information.

There is 40 headwalls on this project that will have vegetation barriers installed around them. The price per headwall for this project is \$387.50/each. This price compares to \$350.00/each for vegetation barriers installed on two other projects in the state this year. This price is fair and reasonable.

The Fargo Assistant District Engineer review and approved this change order on October 5, 1998.

Work Plan

Vegetation Barriers Around Headwalls of Edge Drains Experimental Feature ND 98-03

Objective

The objective of this experimental feature is to determine if constructing vegetation barriers around the headwalls of edge drains would help solve the problem of vegetation and debris from blocking the drain.

The present practice to outlet drainage pipe is to place a 4" PVC outlet pipe approximately every 250 feet. This 4" PVC discharge pipe is capped with a headwall splash block. These headwalls often become blocked with debris to the point it hinders the drainage system.

The TRB report on the "Effectiveness of Subsurface Drainage" indicates that in addition to construction, maintenance appears to be a key factor in the performance of drainage systems. Inspection data indicates only 50 percent of the headwalls inspected were free of debris.

Scope

Construction of two types of headwall barriers on three projects across the state will provide performance data needed for a full evaluation. Should this evaluation show that barriers reduce maintenance costs, changes can be made to edge drain specifications and drawings in future projects.

Location

Three projects have been selected to receive the vegetation barriers. Each project will have a one mile test section. These are:

IM-8-029(025)053	Mile 58 (sta.3062+37) to Mile 59 (sta.3115+15)
IM-2-094(016)240	Mile 243 (sta.12829+89) to 244 (sta.12882+70)
IM-5-094(008)071	Mile 76 (sta.4013+12) to Mile 77 (sta.4066+53)

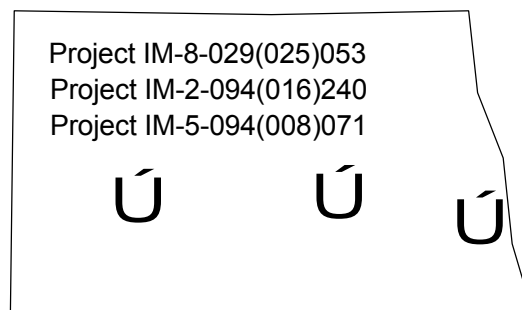

Design

A 4' x 6' vegetation barrier section is proposed to be constructed around each edge drain headwall. Two types will be constructed, one using concrete and one using aggregate.

The concrete barrier will be 4" thick measuring from the top of the headwall. The concrete will be placed on the soil. The concrete is to be reinforced with 6" x 6" wire mesh. Placement of the wire mesh is shown in figure 2 on page 3. The wire mesh will be placed two inches below the surface of the concrete. The Portland Cement Concrete for vegetation barriers will be a Class YE concrete as specified in Section 802 of the Standard Specifications for Road and Bridge Construction.

The aggregate barrier will be 6" in depth measuring from the top of the headwall. A geotextile meeting the properties of a type S2 will be placed under the aggregate. The aggregate will meet the following gradation. The gradation is a modified version used by the Kentucky Department of Transportation. Figure 3 on page 4 shows the aggregate barrier. A cross-section view of each type is shown in figure 1.

Sieve Size - Percent Passing	
3"	100
2½"	90-100
¾"	0-5

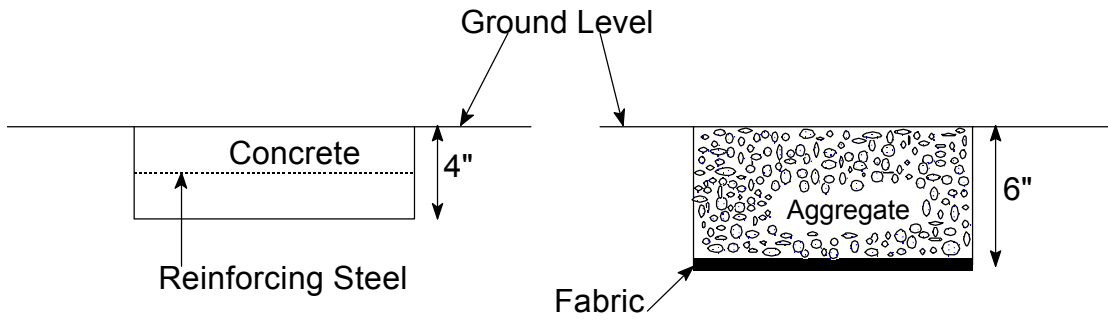

Figure 1

On each project, place either the aggregate or concrete barrier at the left drain outlets for the first half mile. The other barrier type will be placed on the right. Reverse this placement for the last half mile. An example is shown in figure 4. Each experimental section of each project will be marked by a begin and end sign.

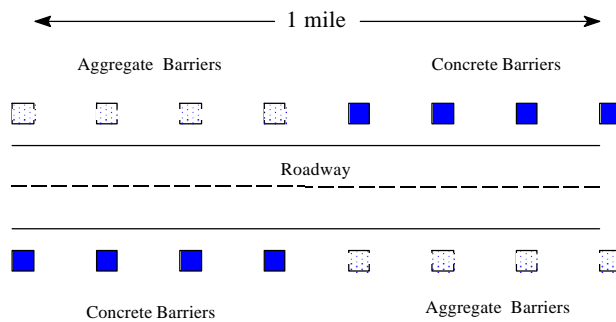

Figure 4

Evaluation

This experimental feature will have an evaluation period of five years. A construction report will be written upon completion of the experimental project. The report will include:

- < Construction costs for each type of barrier section.
- < Constructability of each type of section.
- < Equipment needed for construction of these vegetation barriers.

Evaluation reports will be written annually and will include the following.

- < Performance of the vegetation barrier types.
- < Cost of maintaining each barrier type.
- < Advantages and disadvantages will be noted.
- < Document the amount of vegetation and debris in each type of section

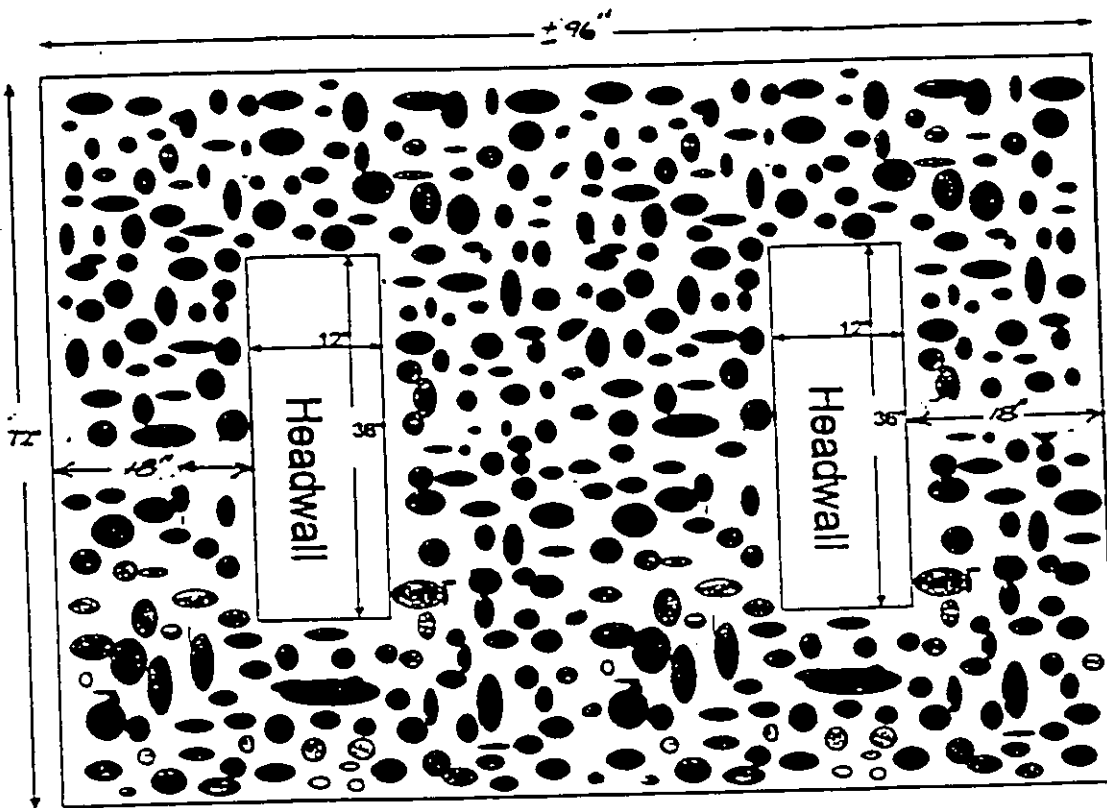

Aggregate Barrier

Aggregate Barrier

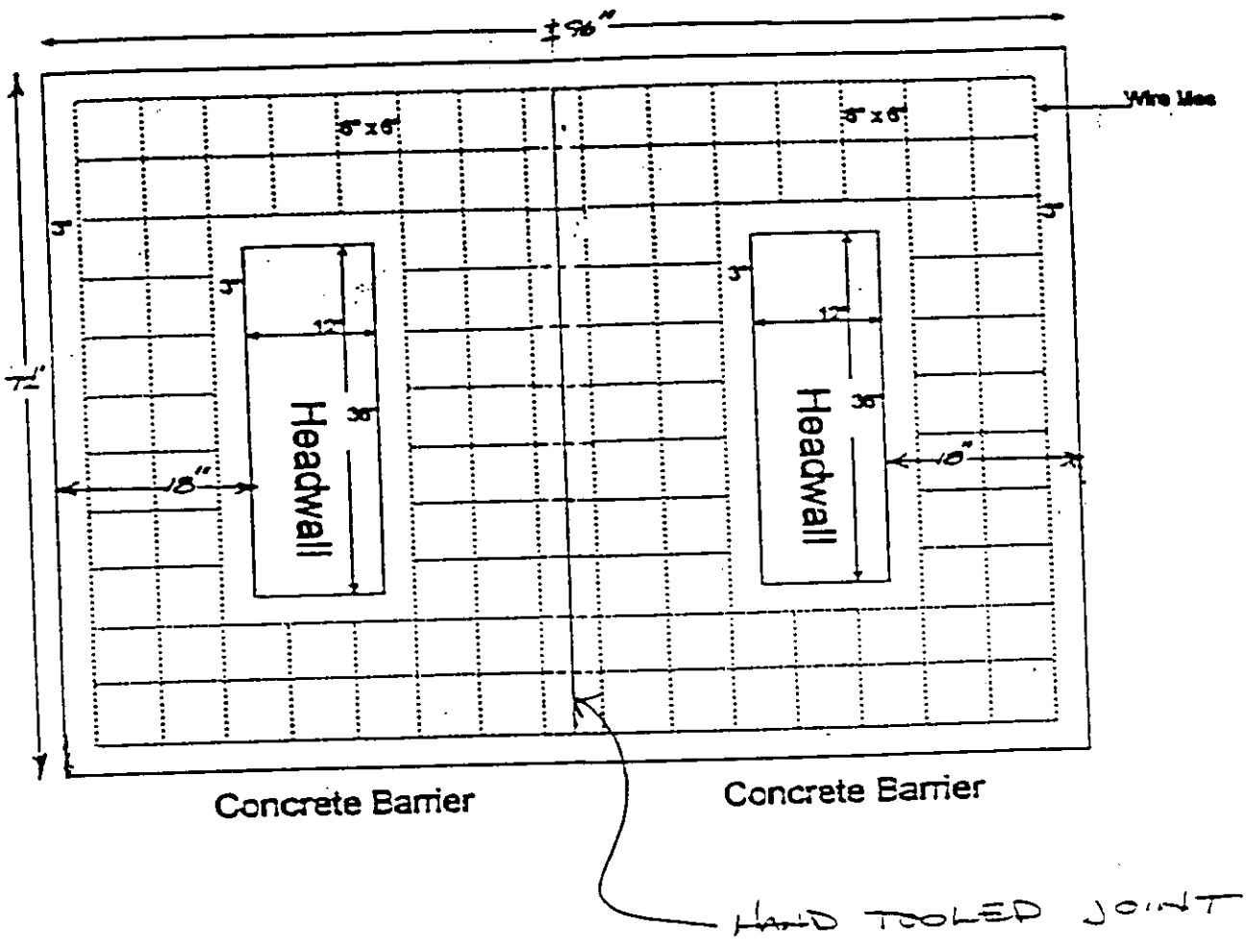

September 30, 1998

Mr. Phil Duginski
Northern Improvement Co.
4000 12th Ave. N.W.
P.O. Box 2846
Fargo, North Dakota 58108-2846

RE: Project IM-8-029(025)053

Dear Phil:

I am requesting a price to install VEGETATION BARRIERS around headwalls of edge drains. The attached sheets show the locations and design to do this work.

Each barrier will have two headwalls and be approx. 96" x 72". There will be 10 concrete barriers and 10 aggregate barriers. The item name and quantity will be VEGETATION BARRIERS, CONCRETE - 10 EA and VEGETATION BARRIERS AGGREGATE - 10 EA.

The price for Vegetation Barriers shall include full compensation for all labor, equipment, and materials to complete this work.

If you have any questions, feel free to contact me.



Duane Carlstrom,
North Dakota Department of Transportation

NORTH DAKOTA DEPARTMENT OF TRANSPORTATION
CHANGE ORDER

SPN 11570

SHEET 1

CH 11P
ORDER NO: 11C

PROJECT: ~~IN-3-029(026)053~~

COUNTY: ~~CASS COUNTY~~

FOR: ~~PCB PUMP, GRADING, SURFACING, AND LIGHT.~~

CONTRACTOR: ~~NORTHERN IMPROVEMENT CO.~~
~~PO BOX 2846~~
FARGO, ND 58102

ORIGINAL CONTRACT AMOUNT
\$ 8,236,161.53

DATE: 09/28/1999

SPEC CODE NO NO	ITEM OF WORK	UNIT	ORIG + OR - PREVIOUS CHG QUANTITY	+ OR - QUANTITY	UNIT PRICE	INCREASE AMOUNT	DECREASE AMOUNT
--------------------	--------------	------	---	--------------------	---------------	--------------------	--------------------

ADDED CONTRACT ITEM

PARTICIPATING (IN FEDERAL FUNDS)

714	2 EDGE DRAIN HEADWALL VEGETATION BARRIER	10	0.000	10.000	845.000	8,450.00	
-----	--	----	-------	--------	---------	----------	--

NET INCREASE OR DECREASE TO DATE	71,101.81	PART	54,447.00	NON-PART	TOTALS	8,450.00	0.00
					NON-PARTICIPATING	0.00	0.00
					PARTICIPATING	8,450.00	0.00

DUE TO THIS CHANGE, THE CONTRACT TIME:
IS INCREASED BY 2 WORKING DAYS.

EXPLANATION OF CHANGE IN PLAN RECOMMENDED

If the Federal Funds authorized in the cost participation agreement with the local agency is exceeded and Federal Funds are not available for this change, the local agency will assume the total cost of this change order.

SEE ATTACHED SHEETS.

Neil Dyer

9-29-99

Alan R. Hessler

VB

CONTRACTOR _____ DATE

Approved Recommended
PROJECT ENGINEER

Approved
DATE

NA

CITY/COUNTY/OTHER OFFICIAL _____ DATE

Approval Recommended
DISTRICT ENGINEER

Approved
DATE

289

NA

REPRESENTING _____

Approved
REGION ENGINEER

DATE

EXPLANATION OF CHANGE ORDER
Project IM-8-029(026)053

714-0002 EDGEDRAIN HEADWALL VEGETATION BARRIER:

On last years project, two types of low maintenance vegetation barriers were placed at the outflow end of the edge drain systems. The two types of barriers were made up of either concrete or an aggregate cushion. The concrete area has performed well and has required no maintenance outside of the normal ditch mowing. However, the aggregate cushion area has brought up some concern by the maintenance forces. The major concern is that on several occasions the aggregate has been picked up by the mowers and thrown out from under the mower deck. At this time no vehicles have been struck by the flying rock but there is a potential for that to occur. If a rock is tossed by the mowers and it strikes the windshield or window of a passing vehicle the result could be devastating. (See letter from NDDOT Maintenance Superintendant)

We have received a price from the prime contractor to change the aggregate cushion areas to concrete. The quoted price is reasonable when you compare it to last years change order price and the fact that the work will be the same. Last years approved change order price was \$350/ea and the quoted price to change the aggregate areas to concrete would be \$345/ea. The design of the concrete vegetation barriers would be the same as last years. (See attached information)

MEMORANDUM

TO: Gray Heisler: TEIII

FR: ^{Bruce Nord}
Bruce Nord, Maint. Supt.

DT: 9-30-99

SU: Edge drain on I-29

Over the 21 years that I have worked for the DOT in the maintenance. I have seen a lot of changes, some good and some not so good. When you look at maintenance you look for ways to make your job easier. However last year when the vegetation barriers were installed on the outflow end of the edge drain systems on I-29 I can see we are in for some problems. The concrete area that was installed around the edge drains are working well. On other edge drains on this roadway had rock installed around the drains for vegetation control. We have over the years had a problem with are mowers picking up rocks and thrown them at cars or pickups on the roadways when we are mowing. As of today we have not had a mower accident on this roadway.

If you were to go back and look at the accident reports from past years you would see that this is something that we need to change. I can not sit in a court of law and say that we didn't know that a rock can be picked up and thrown from a mower. Before I was the Maintenance Superintendent I was a Equipment Operator who had to fill out an accident report on a rock that hit a vehicle. I thank the lord, that the rock hit the back side window and not the windshield.

PROJECT IM-8-029(026)053

HEAD WALLS VEGETATION BARRIERS

The Fargo District Administration has requested that the aggregate barriers that were installed in 1998 to be reconstructed because of a possible flying rock hazard.

This reconstruction will involve the following details:

The existing 96"x72" (approx.) with a 6" depth aggregate barriers will be replaced with a concrete barrier which will be approx 96"x72" with a 4" depth of concrete and with 2" of the existing rock left in place for a base. 4" of the existing rock will be removed and disposed off the right-of-way by the Contractor. The concrete is to be reinforced with 6"x6" wire mesh. The wire mesh will be placed two inches below the surface of the concrete. The Portland Cement Concrete for this vegetation barriers will be a Class YE concrete.

The location of the existing aggregate barriers are from Mile 58 (sta. 3062+37) to Mile 59 (sta. 3115+15). There are 5 aggregate barriers on the west in slope and 5 aggregate barriers on the east in slope of the south bound roadway for a total of 10.

See attached sheets for additional information.



HOME OFFICE
 FARGO, NORTH DAKOTA
 4000 12th Avenue N.W.
 58108-2646
 P.O. Box 2946
 Phone 701-277-1225
 Fax 701-277-1516

OFFICE AT
 BISMARCK, NORTH DAKOTA
 58502-1254
 P.O. Box 1254
 Phone 701-223-0685
 Fax 701-224-0937

OFFICE AT
 DICKINSON, NORTH DAKOTA
 58502-1035
 P.O. Box 1035
 Phone 701-225-5187
 Fax 701-225-0207

NORTHERN IMPROVEMENT COMPANY

J.L. McCormick, Chairman of the Board
 Thomas McCormick, President/CEO
 Steve McCormick, Executive Vice-President

September 20, 1999

Mr. Duane Carlstrom
 North Dakota Department of Transportation
 503 South 38th Street
 Fargo, ND 58103

RE: PROJECT IM-8-029(026)053
 CASS COUNTY

Dear Duane:

Our price to modify the rock vegetation barriers located in the shoulder inslopes of the southbound I-29 roadway in accordance with your letter dated August 19, 1999 is as follows:

10 EACH @ \$845.00/EACH = \$ 8,450.00

- This price does not include flagging, traffic control signing or reseeding of areas disturbed by this work.
- This extra work should not affect final acceptance of the southbound roadway (Project AC-IM-8-029(025)053) constructed in 1998.
- Completion of this extra work should not be included in the contract completion date for Project IM-8-029(026)053.

If you have any questions or need additional information, please call.

Very truly yours,

NORTHERN IMPROVEMENT COMPANY

Phil Duginski
 Phil Duginski

PD:po

