

RESEARCH REPORT DOCUMENT PAGE

1. Report No. ND 95-02	2. Report Date October 2001	3. Contract No. N/A	4. Project No. IM-6-029(011)175
5. Title and Subtitle Crushed PCC for Drainable Base Material		6. Report Type Work Plan <input type="checkbox"/> Construction <input type="checkbox"/> Evaluation <input type="checkbox"/> Final <input checked="" type="checkbox"/>	7. Project No. 8. Project No. 9. Project No. 10. Project No.
11. Author(s)/Principle Investigator(s) Curtis Dunn/Tom Bold/Bryon Fuchs			
12. Performing Organization Name and Address NDDOT M+R <input checked="" type="checkbox"/> North Dakota DOT NDDOT OTHER* <input type="checkbox"/> Materials and Research Division NDSU <input type="checkbox"/> 300 Airport Road UND <input type="checkbox"/> Bismarck ND 58504-6005 UGPTI <input type="checkbox"/> OTHER* <input type="checkbox"/> *see supplementary notes		13. Sponsoring Agency Name and Address North Dakota DOT Materials and Research Division 300 Airport Road Bismarck ND 58504-6005	
14. Supplementary Notes			
15. Abstract Purpose and Need Past research has indicated that a drainable base located beneath pavement will increase pavement life. During reconstruction of PCC pavements, there is a need to recycle the existing material as not to deplete existing natural resources. The purpose of the project is to construct a PCC pavement with drainable base using virgin and recycled material in the drainable base. There was a need to determine if leachate from the recycled material will clog the edge drains and become ineffective. Objective The objective of this study was to compare the performance of crushed portland cement concrete (PCC) and virgin aggregate with a two-fractured face requirement for use as a drainable base material under PCC pavement. Scope The project is designed with the objective of comparing effectiveness of three drainable bases containing of 100% crushed PCC, 100% virgin aggregate, or a 50/50 blend of each. This study addressed the concern that the drainable bases using crushed PCC could have a clogging effect on the drainage system. Several states have experienced leachate on similar projects in the past. The study will evaluate and compare the distresses in the various sections and monitor the edge drains for accumulation of leachate. The evaluation will continue for a period of five years with evaluations annually. The project is located on Interstate 29 in the northbound lane between reference points 175.1 to 183.15. Summary Longitudinal and transverse cracking was observed in all test sections. The amount of cracking is very minor in each section and there is not a sufficient amount of cracking in one section vs. another section to state that one permeable base reduces or increases the amount of cracking in PCC Pavement. Materials and Research observed and evaluated several edge drainpipes located in the three different permeable base course sections. The six years of evaluation detected a material that is similar to a leachate or soil sediment. Some of this material is present in all three-test sections; however, volumes are not sufficient to prevent proper operation of the edge drain systems. The edge drain systems continue to be in excellent condition, with the exception of grass clippings covering the head walls. The headwalls should be kept clean to prevent damming of draining water and material, which could result in flow restrictions in the edge drain system. Results obtained from experimental project ND 98-03, (<i>Vegetation Barriers Around Headwalls of Edge Drains</i>); indicate that the use of vegetation barriers can be effective in decreasing the accumulation of grass clippings thereby reducing headwall maintenance. There appears to be no increase in leachate and/or pavement distresses when recycled PCC Pavement is used as a drainable base material. Recommendation It is recommended that 100 percent recycled pavement be used in the construction of permeable base.			
18. Key Words Base Sub-base Drainable Base Crushed PCC Aggregate	19. Distribution Statement No restrictions. This document is available to the public from: North Dakota Department of Transportation Materials and Research Division: 300 Airport Road Bismarck ND 58504-6005 Office: (701) 328-6900	20. No. of Pages 37 21. File type/Size pdf/1.9 MB	

**NORTH DAKOTA
DEPARTMENT OF TRANSPORTATION**

**MATERIALS AND RESEARCH
DIVISION**

Experimental Study ND 95-02

Crushed PCC for Drainable Base Material

Final Report

Project IM-6-029(011)175

October 2001

Prepared by

NORTH DAKOTA DEPARTMENT OF TRANSPORTATION

BISMARCK, NORTH DAKOTA

Website: <http://www.discovernd.com/dot/>

DIRECTOR

David A. Sprynczynatyk

MATERIALS AND RESEARCH DIVISION

Ron Horner

EXPERIMENTAL PROJECT REPORT

EXPERIMENTAL PROJECT	EXPERIMENTAL PROJECT NO.					CONSTRUCTION PROJ NO	LOCATION
	1	STATE ND	YEAR 95	NUMBER 02	SURF 8	IM-6-029(011)175	Walsh County 28
	EVALUATION FUNDING					NEEP NO.	PROPRIETARY FEATURE?
	48	1 <input checked="" type="checkbox"/> HP&R		3 DEMONSTRATION	<input type="checkbox"/>	Yes	
		2 CONSTRUCTION		4 IMPLEMENTATION	49	51 <input checked="" type="checkbox"/> No	
SHORT TITLE	TITLE Crushed PCC for Drainable Base Material 52						
THIS FORM	DATE	MO.	YR.	REPORTING			
	140	1	0	0	1	1 INITIAL	2 ANNUAL
						3 <input checked="" type="checkbox"/> FINAL	
KEY WORDS	KEY WORD 1			KEY WORD 2			
	145	BASESUBBASE		167	AGGREGATE		
	KEY WORD 3			KEY WORD 4			
	189	DRAINABLEBASE		211			
	UNIQUE WORD			PROPRIETARY FEATURE NAME			
	233	CRUSHED PCC		255			
CHRONOLOGY	DATE WORK PLAN APPROVED:	DATE FEATURE CONSTRUCTED:	EVALUATION SCHEDULED UNTIL:	EVALUATION EXTENDED UNTIL:	DATE EVALUATION TERMINATED:		
	03-95	11-95	10-00				
	277	281	285	289	293		
QUANTITY AND COST	QUANTITY OF UNITS		UNITS		UNIT COST (<i>Dollars, Cents</i>)		
	<input type="text"/>		1 LIN. FT 5 TON		<input type="text"/>		
	58348		2 <input checked="" type="checkbox"/> SY 6 LBS		3.72		
			3 SY-IN 7 EACH				
			4 CY 8 LUMP SUM				
	297		305		306		
AVAILABLE EVALUATION REPORTS	<input checked="" type="checkbox"/> CONSTRUCTION		<input checked="" type="checkbox"/> PERFORMANCE		<input checked="" type="checkbox"/> FINAL		
	315						
EVALUATION	CONSTRUCTION PROBLEMS			PERFORMANCE			
	1 NONE			1 EXCELLENT			
	2 <input checked="" type="checkbox"/> SLIGHT			2 <input checked="" type="checkbox"/> GOOD			
	3 MODERATE			3 SATISFACTORY			
	4 SIGNIFICANT			4 MARGINAL			
	318	5 SEVERE		****	5 UNSATISFACTORY		
APPLICATION	1 ADOPTED AS PRIMARY STANDARD	4 PENDING		<i>(Explain in remarks if 3, 4, 5, or 6 is checked)</i>			
	2 PERMITTED ALTERNATIVE	5 REJECTED					
	320	3 ADOPTED CONDITIONALLY		6 NOT CONSTRUCTED			
REMARKS	321 The final evaluation showed there is no significant amount of sediment/leachate in the edge drains. This is true for all types of permeable bases. There appears to be no correlation between the amount of sediment or leachate detected and the amount of crushed PCC present in the permeable base course.						

Experimental Study ND 95-02

Crushed PCC for Drainable Base Material

Final Report

Project IM-6-029(011)175

October 2001

Written by

Curtis Dunn/Tom Bold/Bryon Fuchs

Disclaimer

The contents of this report reflect the views of the author or authors who are responsible for the facts and the accuracy of the data presented herein. The contents do not reflect the official views of the North Dakota Department of Transportation or the Federal Highway Administration. This report does not constitute a standard, specification, or regulation.

TABLE OF CONTENTS

Objective	1
Scope	1
Location	2
Traffic	3
Design	4
Construction	4
Evaluation	5
Summary	11
Recommendation	12
Appendix A: Construction Plans	A-1
Appendix B: Specifications	B-1
Appendix C: Evaluation Data	C-1

CRUSHED PCC FOR DRAINABLE BASE MATERIAL

Objective

The objective of this study was to focus on the utilization of crushed portland cement concrete (PCC) for a drainable base material, and determine if a drainable base consisting of crushed PCC material will perform as well as a drainable base consisting of virgin aggregate that has a two fractured face requirement.

There was also concern that the drainable bases using crushed PCC would have a clogging effect on the drainage system due to excess precipitate (leachate) coming from the crushed PCC sections. Several states have experienced leachate on similar projects in the past. A leachate is defined as a separation or dissolving out of soluble constituents from a rock by percolation of water.

Scope

The project was designed with the objective of comparing the cost and effectiveness of three drainable bases containing of 100% crushed PCC, 100% virgin aggregate, or a 50 - 50 blend of each.

This study was implemented to determine if the degree of leachate would increase or decrease as compared to the previous year. And whether the leachate would accumulate to the point that it threatens the drainage performance of the pipe and ultimately the durability of the pavement structure.

An optical camera was used to evaluate the condition of the 4" perforated pipe used in the edge drain system and will be discussed later in the report.

Location

The project is located in Walsh County, North Dakota, on I-29 just south of junction 17 running north to the Herrick Interchange, northbound. The project starts and ends at mile markers 175.1 and 183.15, respectively. The project length is 8.050 miles.

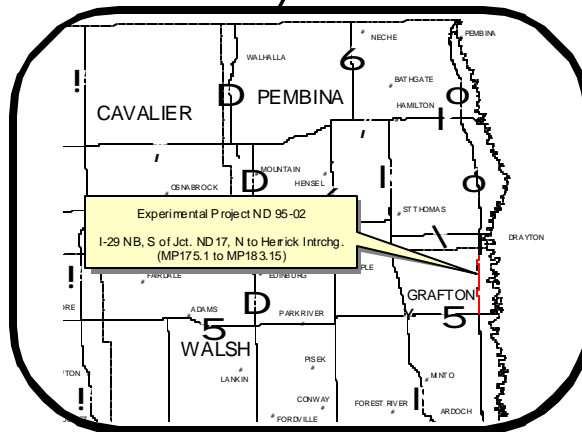
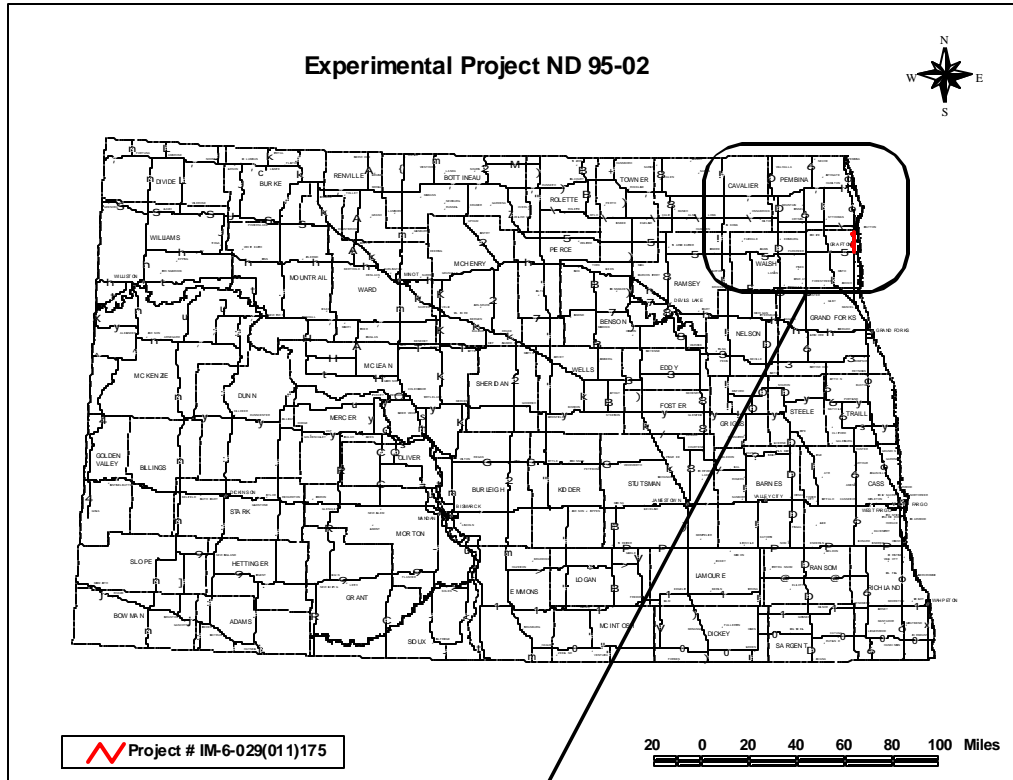

Traffic

The one-way traffic estimates for the northbound lane are shown below in Table 1.

Year	Pass. Car	Trucks	Total	30TH Max Hr	Rigid EASLs
1996	1,410	550	1,960	240	780
1997	1,430	550	1,980	220	820
1999	1,980	560	2,540	255	825

Table 1

Details identifying the project location and additional section information are included in Appendix A. An overall view of the project is provided in photo 1.



Photo 1. Overview of project location

Design

Project IM-6-029(011)175 from Junction ND 17 North to Herrick Interchange was constructed in 1995 with a 4" salvaged base, a 4" cement treated permeable base equipped with edge drains, and 9.0" of doweled recycled PCC.

Permeable base course for the project was designed with one-third of the project using 100% crushed PCC, one-third using virgin aggregate and one-third using a 50/50 blend of crushed PCC and virgin aggregate.

The permeable base course built with 100% virgin aggregate is located between stations 1821+52.0 and 1965+50.0. The permeable base course built with 50/50 blend of crushed PCC and virgin aggregate is located between stations 1965+50.0 and 2109+00.0, and the permeable base course built with 100% crushed PCC is located between stations 2109+00.0 and 47+08.67.

Construction

Construction began on IM-6-029(011)175 (NB), on June 5, 1995. It was awarded to Progressive Contractors, Inc., based in Osseo, Minnesota.

The Materials and Research Division of the North Dakota Department of Transportation (NDDOT) visited the site on several occasions during construction. Project engineer Richard Parton said the contractor experienced no major problems working with the three different permeable base materials that would warrant preference of one over the other. Construction on the project was completed on July 23, 1996.

Evaluation

Materials and Research conducted the final evaluation of experimental project ND 95-02 on August 28, 2001 and September 11, 2001. The evaluation consisted of an internal inspection of the edge drain system. The purpose of the edge drain inspection was to monitor leachate formation as it relates to the different base materials utilized on this project. These results will be compared to the initial inspection of the edge drains performed immediately after construction in the fall of 1995. Also included are visual observations of the edge drain headwall condition, and condition of the pavement at the general location of each inspected edge drain.

A color flexiprobe inspection system manufactured by Pearpoint Inc., consisting of an optical camera and a color monitoring unit, was again used for this purpose. A video cassette recorder was available to record any pertinent information that might be of use in future inspections of the same pipes. There were no significant changes to the internal edge drain system; consequently, a video recording of the edge drains using the optical camera was not included in the final evaluation.

A visual inspection of the headwall outlets showed that most of the discharge pipes had been previously draining. Physical condition of the headwalls was excellent; however, 6 of 10 (60%) were either covered with grass clippings or had significant amounts of grass clippings in the headwall drainage path that could cause potential damming. The headwall was missing at Station 1875+35L. Since the headwall was not in place, the rodent screen was also missing, allowing potential entrance of small animals.

The drains that were experiencing ponding of water, during the initial observation, were absent of water during the following evaluations. During the final evaluation, the edge drain systems were either dry or had condensation on top of the pipe. Unlike the initial scoping of the edge drains in 1995, the weather conditions were warm and dry for several days prior to the subsequent evaluations.

Permeable base containing 100% crushed PCC

The analysis was expanded to include additional edge drains during the third annual evaluation. The location of edge drains evaluated in this test section are as follows:

Sta.2162+50L, Sta.2160+60L, Sta.2140+00L, and Sta.2137+50L.

As in previous evaluations, the edge drains in this section were not experiencing any significant problems relating to leachate settlement in the pipes. Some isolated areas are experiencing a substance or residue adhering to the pipe walls to a depth 1/3 to 1/2 of the pipe.

The headwalls in this section were in excellent physical condition. Two (2) were covered, or contained a significant amount of grass clippings .

The final evaluation identified approximately 210' of longitudinal cracking and four (4) transverse cracks in this test section. Approximately ten (10) corner breaks were also noted.

During the final evaluation the roadway pavement (observed approximately $\pm 100'$ either side of headwall) was experiencing small corner cracking of pavement panels, and spalling of the edges at the connection of the driving lane and shoulder. Frequent corner cracking, spalling of cracks and breaking up of corners was observed. Photo 2 shows a typical pavement distress in this test section of the project. The longitudinal shoulder joint is separating at several locations. The separation is 3/8" to 1/2" in areas.



Photo 2. Typical Pavement Distress (Sta. 2160+60L) . Note the snowplow marks on the shoulders.

Permeable base containing 50% crushed PCC and 50% virgin aggregate

The analysis was expanded to include additional edge drains during the third annual evaluation. The location of edge drain evaluation in this test section are as follows:

Sta.2073+00L, Sta.2068+50L, and Sta.2004+75L.

As in previous evaluations, the edge drains in this section were experiencing no significant problems related to leachate settlement in the pipes. Again, as in previous evaluations, some isolated areas are experiencing a substance or residue (approximately 1/3 to 1/2 the depth of the pipe) adhering to the pipe walls, as well as collecting small amounts of soil. No standing water was observed in the pipes.

The drain pipe at Sta.2004+75L was observed to be dented approximately 90' from the headwall as observed in the fourth evaluation. The pipe is crushed approximately 164' from the headwall (observed in the fourth evaluation); however, a 3/4" gap for material passage remains and sediment build up was not noted at this location. It appeared that the structural damage is not affecting the performance of the system. The headwalls in this section were in excellent physical condition. Three (3) were covered, or contained a significant amount of grass clippings. Photo 3 illustrates the grass covering the headwall at Sta.2073+00.

Photo 4 shows a typical pavement distress in this test section of the project.



Photo 3. Grass covering headwall (Sta. 2073+00L).

The roadway pavement, (observed approximately $\pm 100'$ either side of headwall), is experiencing spalling of the edges at the longitudinal shoulder joint. Fewer corner cracks were noted in the super elevation portion of this test section. Transverse cracking in the shoulder was also noted. Approximately 60' of longitudinal cracking was observed in this test section. The longitudinal shoulder joint is separating at several locations. The separation is 3/8" to 3/4" in some locations.



Photo 4. Typical Pavement distress (Sta. 2004+75L).

Permeable base containing 100% virgin aggregate

During the first annual evaluation one of the edge drains scoped in this section was experiencing a significant amount of sediment or leachate accumulating on the bottom of the pipe. The analysis was expanded to include additional edge drains during the third annual evaluation. The location of edge drains evaluated in this test section are as follows: Sta. 1927+80L, Sta. 1875+35L, and Sta. 1852+45L.

During the third evaluation it appeared that the amount of sediment had decreased. The final evaluation indicated approximately the same amount of sediment present. This section contained more sediment in the drains than the other two test sections. During one of the earlier evaluations, a small amount of the leachate material was recovered and taken to the central laboratory for testing and found to have a PH of approximately 8.25. Mineral leachate from cement related materials is calcareous in nature and would tend to have a PH higher than 8.74. This may indicate that the material in question would be more inorganic in nature. Additional material was not recovered during the final evaluation.

The drain pipes were dry with no standing water observed. The general physical condition of the pipes is excellent.

The headwalls in this section were in excellent physical condition; however, the headwall at Sta. 1875+35L was missing (Refer to Photo 5). Consequently, the drain pipe was open and there is a potential for damage by mowers but more importantly to become plugged and not allow water to drain from the pipe. Without a rodent screen, an open entrance for rodents exists. Sediment or grass clippings were observed in the other headwalls.



Photo 5. Headwall missing (Sta. 1875+35L).

The roadway pavement, (observed approximately $\pm 100'$ either side of headwall), is experiencing corner cracking of pavement panels, and spalling of the edges at the connection of the driving lane and shoulder. Photo 6 illustrates the typical pavement distress in this test section of the project.



Photo 6. Typical Pavement Distress (Sta. 1875+35L).

Summary

Materials and Research observed and evaluated several edge drain pipes located in the three different permeable base course sections. These sections were composed of either 100% Crushed PCC, 100% Virgin Aggregate, or a 50/50 Blend of Crushed PCC and Virgin Aggregate. Evaluation of the three permeable base sections does not indicate that a significant amount of leachate or sediment has accumulated over the past six years of service.

The evaluation detected a material that is similar to a leachate or soil sediment. Some of this material is present in all three test sections; however, volumes are not sufficient to prevent proper operation of the edge drain systems. This material is collecting on the bottom and on the sidewalls of the pipes, and appears to follow the flow level of the pipe. The depth of flow appears to be approximately 1/3 to 1/2 the depth of pipe as indicated by the residue remaining on the wall of the pipes.

After the final evaluation, there still appears to be no correlation between the amount of leachate/sediment detected and the crushed PCC utilized as base material. As in past evaluations, there is slightly more leachate or sediment being detected in the section containing 100% virgin aggregate.

Longitudinal and transverse cracking was observed in all test sections. The amount of cracking is very minor in each section and there is not a sufficient amount of cracking in one section vs. another section to state that one permeable base reduces or increases the amount of cracking in PCC Pavement.

The edge drain systems continue to be in excellent condition, with the exception of grass clippings covering the head walls. The headwalls should be kept clean to prevent damming of draining water and material, which could result in flow restrictions in the edge drain system. Results obtained from experimental project ND 98-03, (*Vegetation Barriers Around Headwalls of Edge Drains*), indicate that the use of vegetation barriers can be effective in decreasing the accumulation of grass and grass clippings thereby reducing headwall maintenance.

The headwall at Sta. 1875+35L is missing and should be replaced as soon as

possible to prevent damage to the drain outlet pipe and keep rodents out of the edge drain system.

Past evaluations indicated longitudinal cracking and transverse cracking in the 100% Crushed PCC test section. Observations during this final evaluation indicate cracking, spalling, and break-up of corners in panels on all three test sections. Cracking and spalling of the edges at the driving lane / shoulder joint, were commonly observed in all three test sections. There appears to be a general increase in pavement distress in all test sections which is expected as the pavement ages; however, the ride continues to be excellent in all of the test sections.

There appears to be no increase in leachate and/or pavement distresses when recycled PCC Pavement is used as a drainable base material.

Recommendation

Initial observations immediately after construction and this final evaluation (six years later) found no evidence of leachate or sediment clogging the drainage system. Ponding water observed in the drainage system is due to construction of the drainage system (not maintaining the proper grade) and not the result of leachate or sediment clogging the drainage system.

It is recommended that 100% recycled PCC pavement that is crushed be utilized in the construction of permeable bases.

Appendix A

SCOPE OF WORK
(Recycle PCC North Bound Roadway)

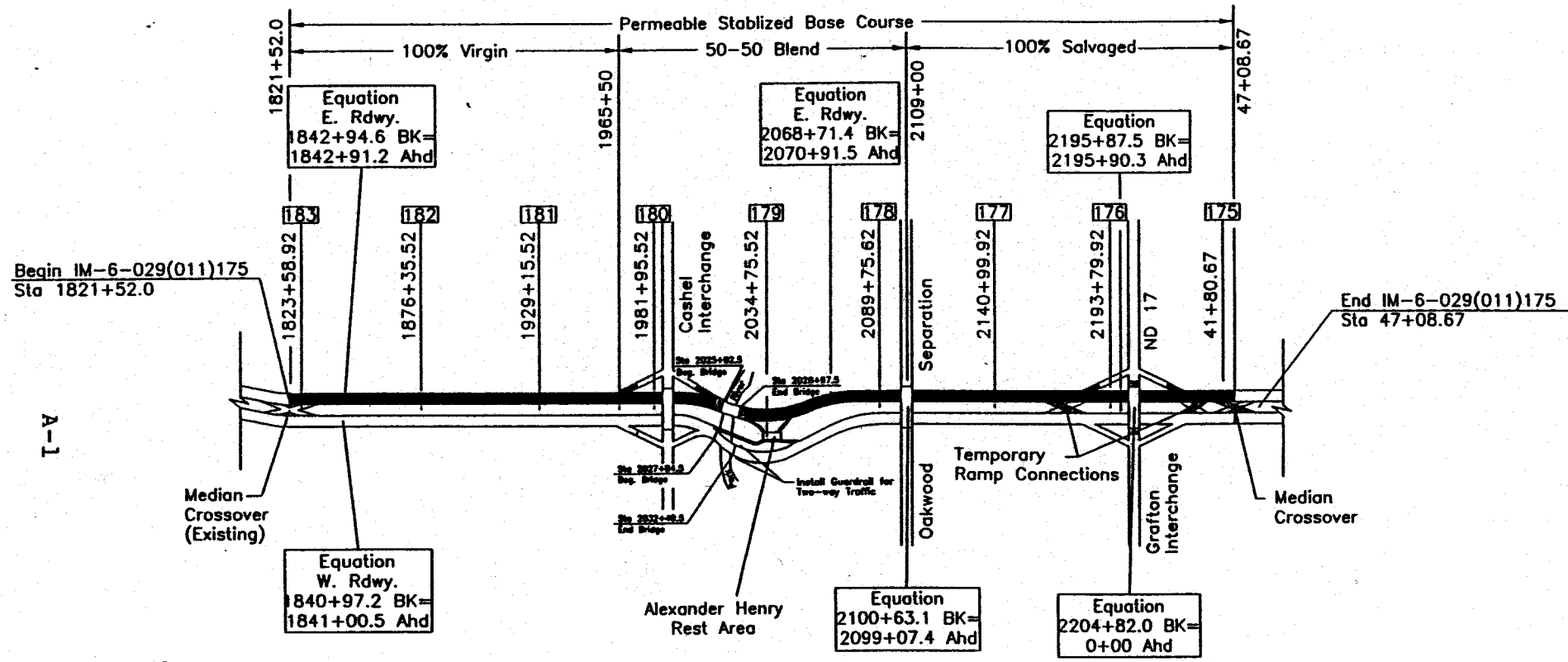

- Indicates area for Recycled PCC
- Indicates Crossovers to be built for future project.
- Approach Slabs and Guard Rail

DESIGN DATA							
Traffic	Average Daily					Est. Max. Hr.	
Current 1995	Pass.	1315	Trucks	235	Total	1550	155
Forecast 2015	Pass.	1955	Trucks	370	Total	2325	233
Minimum Sight Dist. for:		Design Speed		70 MPH			
Stopping		600'					
Full control of access							
No point of access other than at Interchange Ramps							

JOB# 15

FHWA REGION	STATE	PROJECT NO.	SHEET NO.
8	ND	IM-6-029(011)175	1

NORTH DAKOTA DEPARTMENT OF TRANSPORTATION

IN WALSH COUNTY

FEDERAL AID PROJECT NO. IM-6-029(011)175

RECYCLE PCC PAVEMENT (NORTH BOUND)

GOVERNING SPECIFICATIONS:

Standard Specifications adopted by the North Dakota Department of Transportation September 1992; Standard Drawings currently in effect; and other Contract Provisions submitted herein.

LENGTH OF PROJECT

MILES-GROSS	MILES-NET
8.139	8.064
.075 Mi. deducted for structure	

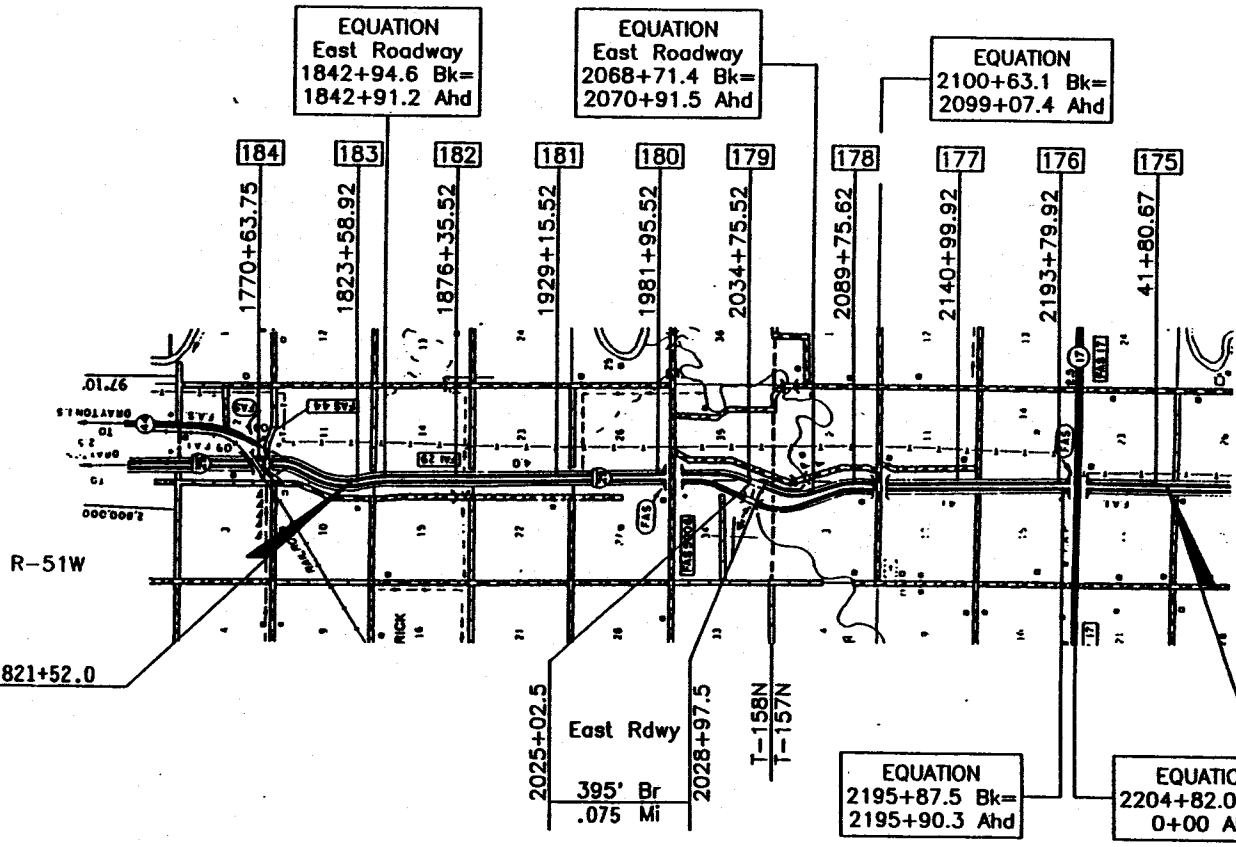

EG IM-6-029(011)175 STA 1821+52.0
Sec 11, Twp 158N, Rge 51W

END IM-6-029(011)175 STA 47+08.67
Sec 23, Twp 157N, Rge 51W

DESIGNING SECTION	<i>Dave Johnson</i>
URBAN SECTION	
TRAFFIC SECTION	
GENERAL SECTION	
COMMEND APPROVAL	3-22-1995
DESIGN ENGINEER	<i>Keith S. Burt</i>

U.S. DEPARTMENT OF TRANSPORTATION
FEDERAL HIGHWAY ADMINISTRATION

APPROVED

DIVISION ADMINISTRATOR

APPROVED DATE 3/24/95

Ray Zink

DIRECTOR OF HIGHWAYS
AND ENGINEERING

NORTH DAKOTA
DEPARTMENT OF TRANSPORTATION



TYPICAL SURFACING SECTION
(Northbound Roadway)
(Mainline)

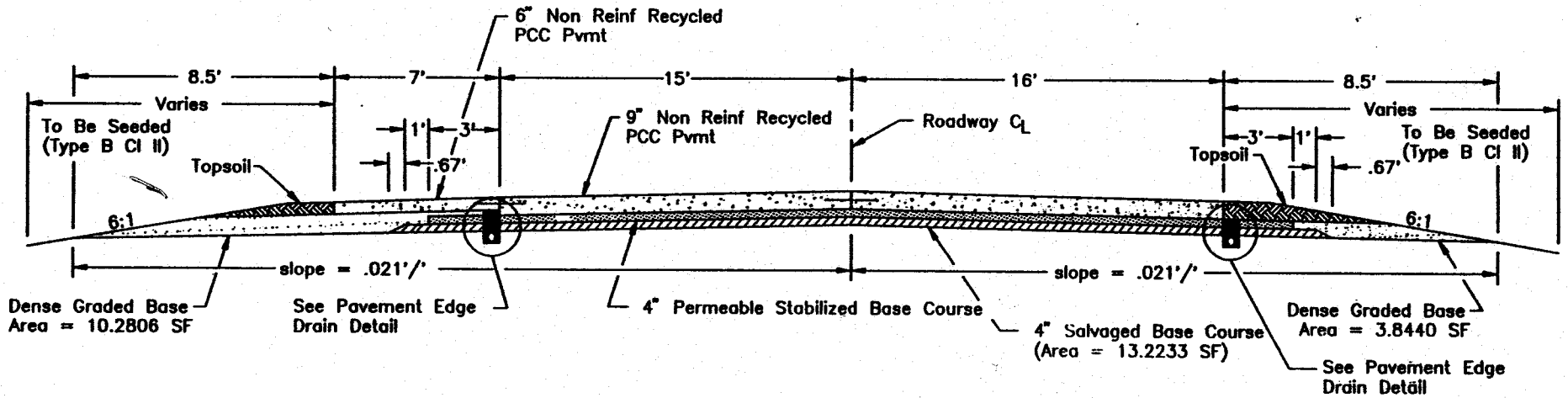

A-3

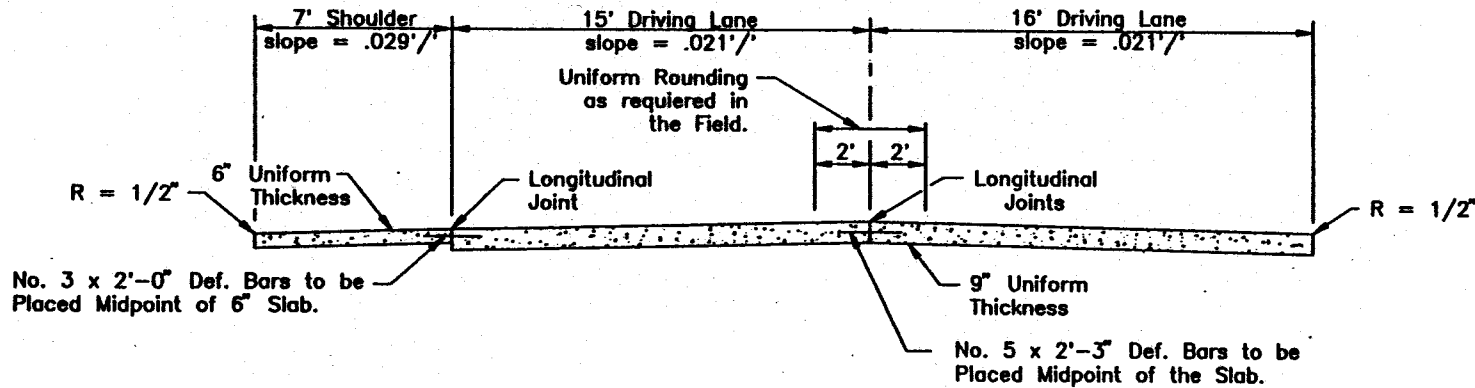

EDGE DRAIN, DISCHARGE PIPE, & SPLASH BLOCK DETAILS

FLIWA REGION	STATE	FED. AID PROJ. NO.	SHEET NO.
8	N.D.		34

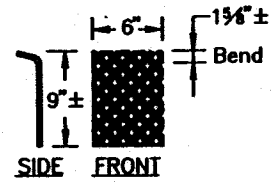
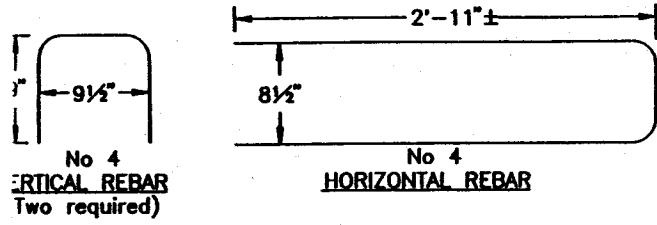

RODENT SCREEN:
 Dimensions are approximate to allow for bend and a snug fit in slot in headwall

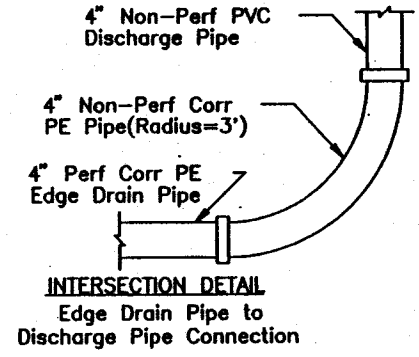
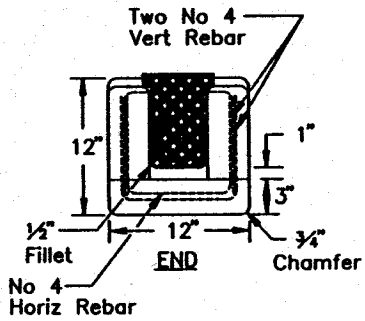
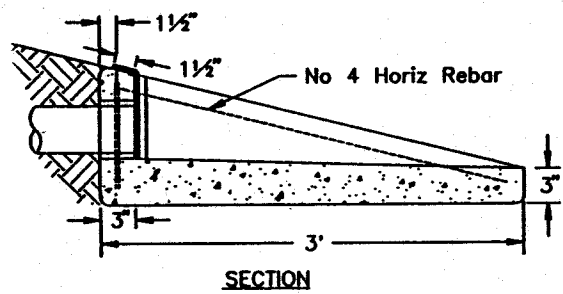
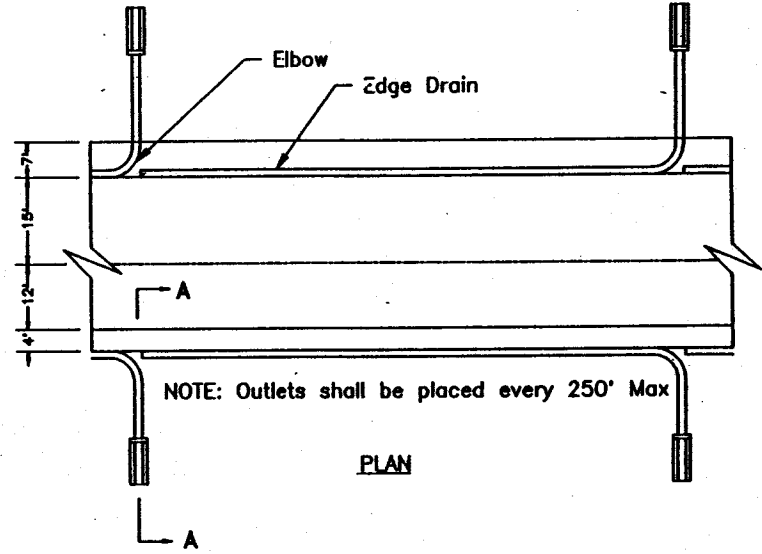
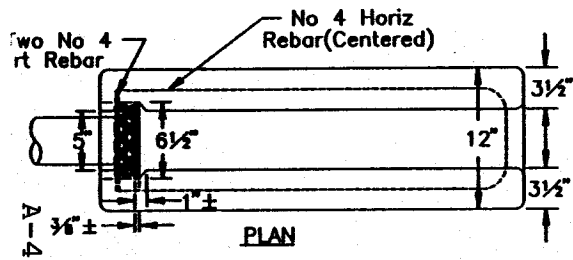

*NOTE: The rodent screen shall be fabricated from flattened expanded metal with screen openings of approximately 0.25 square inches. The screen shall be 16 ga. metal and be hot dip galvanized after fabrication.

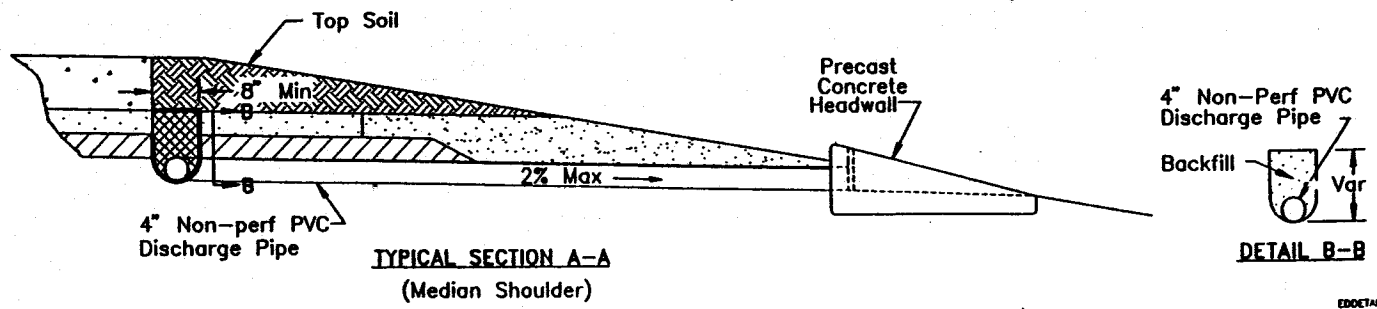

FHWA REGION	STATE	FED. AID PROJ. NO.	SHEET NO.
8	N.D.	IM-6-029(011)175	4

NOTES

100 MEDIAN DRAINAGE: The contractor shall maintain and restore the
 P01 existing median drainage throughout the project. Should any pooling
 occur, the contractor shall provide sufficient temporary pumping or
 drainage to keep the median drained. The cost for maintaining the
 median drainage shall be incidental to the price bid for other items.

100 DISPOSAL: No material except common excavation shall be disposed
 P02 of on the right of way. The contractor will not be required to haul
 this material more than 2,600 feet.

200 SHRINKAGE: 35 percent additional volume in yardage computed by the
 010 end area method is allowed for shrinkage in earth embankment.

200 BORROW HAUL: No average haul has been computed for this project.
 P01

202 REMOVAL OF BITUMINOUS SHOULDER SURFACING (TEMPORARY CONNECTIONS):
 P01 The contractor shall remove and dispose of the existing bituminous
 inside shoulder material where the median crossover or ramp
 connections intersect the mainline shoulders. The material shall
 not be used for embankment but shall be disposed of at a site
 selected by the contractor and approved by the engineer. Disposal
 in wetland areas will not be approved. All costs for obtaining the
 disposal site and for removing, loading, hauling, and disposing of
 the material shall be included unit price bid for "Removal of
 Bituminous Surfacing."

The contractor shall remove any unstable subgrade material from the
 shoulders and dispose of it within the right of way, as directed by
 the engineer. Plan quantity is based on a 2'-6" subcut. The unit
 price bid for "Common Excavation - Type C" shall include all costs
 for excavating, loading, hauling, and placing the material.

202 REMOVE BITUMINOUS PAVEMENT: At Sta. 47+08.67 the median shoulder of
 P02 the east roadway shall be colter cut or saw cut as shown on the
 plans to provide a taper from the new 4-foot shoulder to the
 existing 10-foot shoulder. The pavement shall be left in place on
 the shoulder taper. The rest of the hot bituminous pavement shall
 be removed. This work shall be completed once traffic has been
 returned to normal operation, after recycling on the east roadway
 has been completed. All costs to saw or colter cut the connection,
 remove and dispose of the surfacing shall be included in the unit
 price bid for "Removal of Bituminous Surfacing."

202 REMOVAL OF STRUCTURE: This item includes the removal of the
 P03 finger-type expansion joint, box drainage structure, and
 8" x 22' CMP located at Stations 2023+03.2 and 2030+96.8 on the east
 roadway. After removal of the joint, it shall be backfilled with
 granular fill approved by the engineer (approx. 10 CY per
 location). All joint material removed shall become the contractor's
 property. The unit price bid for "Removal of Structure" shall
 include all cost to complete this work.

203 RAMP CONNECTION DETOURS: The embankment material required for
 P01 constructing the ramp connection detours shall be obtained by the
 contractor.

Embankment material for the ramp connection detours shall be paid
 for as "Borrow." Cost for surfacing temporary bypasses shall be
 paid for at the unit price bid for each item.

See plan sheets for estimated grading and surfacing quantities.

203 STRUCTURE CLEARANCE: Adjust the grade as directed by the engineer
 P02 to assure a minimum vertical clearance of 16'-6" (from the top of
 the P.C.C. pavement) under structures. Use AASHTO T-99 for
 recompaction and density control of 12-inch scarification of
 roadbed. Include the costs to excavate, scarify, and recompact in
 the unit price bid for "Common Excavation - Type C."

203 COMPACTION AND DENSITY CONTROL: Use AASHTO T-99 for compaction and
 P03 density control.

230 RESHAPING CONNECTION: The price bid for this item shall be full
 P01 compensation for all cost to reshape and compact the existing
 temporary connections to the layout shown in the plans. Each
 connection shall be measured and paid for separately.

234 HYDRATED LIME: A quantity of 500 ton of hydrated lime has been
 P01 provided for drying the subgrade if needed.

302 TRIMMING SALVAGED BASE COURSE: In addition to trimming the subgrade
 P01 surface, the salvaged base course shall be trimmed to the required
 grade and cross section in accordance with Section 230.02 B.3 before
 any permeable stabilized base course is placed on the salvaged base
 course. Excess material removed from high points of the salvaged
 base course by the trimming operation shall be reincorporated into
 the salvaged base course.

The cost for providing the required grade and cross section shall be
 included in the unit price bid for "Salvaged Base Course."

302 SALVAGED BASE COURSE: The salvaged base course shall consist of a
 P02 blend of salvaged PCC fines, salvaged bituminous, and salvaged
 aggregate material.

304 PERMEABLE STABILIZED BASE: Portland Cement shall be used as a
 P01 stabilizing agent.

The aggregate for the bid item "Permeable Stabilized Base Course" shall
 not contain aggregate produced from the Salvaged Concrete Pavement.

The aggregate for the bid item "Permeable Stabilized Base Course
 (blended)" shall be a blend of 50% virgin aggregate and 50% aggregate
 produced from the Salvaged Concrete Pavement.

The aggregate for the bid item "Permeable Stabilized Base Course
 (Salvaged)" shall be produced from the Salvaged Concrete Pavement.

ESTIMATED QUANTITIES

FHWA REGION	STATE	FED. AID PROJ. NO.	SHEET NO.
8	N.D.	IM-6-029(011)175	12

SPEC	CODE	ITEM DESCRIPTION	UNIT	MAINLINE	CASHEL INTERCHANGE	ALEXANDER REST AREA	OAKWOOD SEPARATION	GRAFTON INTERCHANGE	TEMPOTARY CONNECTIONS	TOTAL
103	0100	CONTRACT BOND	L SUM	1						1
202	0104	REMOVAL OF STRUCTURE	EA	2						2
202	0113	REMOVAL OF CONCRETE	CY	3						3
202	0123	REMOVE AND SALVAGE AGGREGATE BASE	TON	5,330				185		5,495
202	0130	REMOVAL OF CURB AND GUTTER	LF					160		160
202	0135	REMOVAL OF BITUMINOUS SURFACING	TON						2,523	2,523
203	0103	COMMON EXCAVATION - TYPE C	CY	1,740						1,740
203	0109	TOPSOIL	CY			533				533
203	0140	BORROW	CY			432				432
203	0208	GUARDRAIL EMBANKMENT - TYPE C	EA	2				4		6
210	0198	SELECT BACKFILL	TON	459				350		809
210	0201	FOUNDATION PREPARATION	EA	1				1		2
216	0100	WATER	M GAL	2,826	64	67	71	64	18	3,110
230	0104	RESHAPING CONNECTION	EA						3	3
230	0106	RESHAPING ROADWAY	MILE	8.000						8.000
230	0182	SUBGRADE PREPARATION - TYPE B (12IN)	MILE	8.064						8.064
234	0104	HYDRATED LIME	TON	500						500
302	0100	SALVAGED BASE COURSE	TON	52,038	1,608	1,659		1,608		56,913
302	0120	AGGREGATE BASE COURSE - CL 5	TON	28,820					904	29,724
304	1000	PERMEABLE STABILIZED BASE COURSE	SY	59,363						59,363
304	3000	PERMEABLE STABILIZED BASE COURSE (BLENDED)	SY	56,941						56,941
304	5000	PERMEABLE STABILIZED BASE COURSE (SALVAGED)	SY	58,739						58,739
401	0100	MC-70 OR 250 LIQUID ASPHALT	GAL	36,900					521	37,421
401	0152	SS-1h OR CSS-1h EMULSIFIED ASPHALT	GAL						642	642

Appendix B

Delete the third paragraph of Section 802.01 C. 6. in its entirety.

802.01 DESCRIPTION.

Page 408

11-18-94

Delete Section 802.01 E.1.a. in its entirety and insert the following:

- a. When Type I or IA cement is used, the cement content shall be increased to 7.2 sacks of cement per cubic yard. The maximum water content shall be the same as the water content shown in Table 802.01 B.1. for the class of concrete specified.

810.01 CURING MATERIALS.

Page 414

03-17-95

Add the following to Section 810.01:

Geotextile Fabric. The Geotextile fabric shall be a highly absorbent fabric made from a light colored, nonwoven material that weighs a minimum of eight ounces per square yard.

816.01 FINE AGGREGATE FOR CONCRETE.

Page 415

02-26-93

Insert the following in the footnote for the test method, Lightweight pieces in Aggregate in Section 816.01 A.2. The No. 30 sieve will be substituted for the No. 50 sieve. Agitate the sample by stirring for a period of 15 seconds. Allow the sample to settle for 30 seconds and decant. Perform this procedure until the specimen is free of floating pieces or a maximum of three times.

816.03 AGGREGATES FOR SURFACING, BASE, ASPHALT MIXES, BLOTTER, AND SEAL COATS.

Page 418

09-18-92

04-23-93

07-29-94

02-17-95

Delete Section 816.03 B. in its entirety and insert the following:

CLASS OF AGGREGATE AND SPECIFICATION LIMITS

B. Specific Requirements.

Table I: Aggregates for Subgrade Repair, Trench Backfill, Bases, and Surfacing

Sieve Size Percent Passing	Permeable Trench Backfill	Aggr. for Subgrade Repair	Shldr. Aggr. Surface	Aggr. Base	Permeable Base Aggr.	Temp. Traffic Surface Aggr.	Aggr. Surface
	2	3	4	5	7	8	13
3"		100					
1-1/2"						100	
1-1/4"							
1"				100	100		100
3/4"	100		100	90-100	95-100		70-100
5/8"							
1/2"					85-100		
3/8"	50-95				60-90		
No. 4		35-85	35-85	35-70	15-25	35-80	38-75
No. 8					2-10		22-62
No. 10	0-15						
No. 16					2-5		
No. 30	0-4	20-50	10-50	16-40			12-45
No. 50							
No. 100							
No. 200		0-15	7-17	4-10	0-3		7-15
Shale ¹		12%	15%	12%	8%	20%	12%
L. A. Abrasion ¹			50%	50%	40%		50%
Plasticity Index ²							
Fractured Faces ³			10%	10%	85%		10%
Footnote Reference							

The moisture and density controls will be the same as those specified on the plans for embankment and cut areas. The subgrade shall be compacted in 6 inch layers to the depth of subgrade preparation specified. If the subgrade is unstable (as evidenced by sponginess or rutting) when compacted to the required density, the soils shall be dried to obtain adequate stability. This may require drying below optimum moisture. The cost of such drying will be incidental to the price bid for subgrade preparation.

234.04 CONSTRUCTION REQUIREMENTS.

Page 133

02-11-94

Add the following sentence to the first paragraph in Section 234.04 C:

The stabilized subgrade shall be compacted to the density specified in the Plans.

302.02 MATERIALS.

Page 139

03-25-94
06-17-94

Delete the first sentence in paragraph two of Section 302.02 B. and insert the following:

Three random samples will be taken for each lot of material placed. If the base material is placed in a windrow on the roadway, the sample will be taken from the equalized aggregate windrow according to the procedures outlined in NDDOT's *Field Sampling and Testing Manual*. If construction operations do not require that the base material be equalized in a windrow, the sample will be taken according to the procedures outlined in AASHTO T-2 with the belt sample given first priority.

302.04 CONSTRUCTION REQUIREMENTS.

Page 141

02-26-93

Delete the last sentence of Section 302.04 G.2. in its entirety and replace with the following:

The taut string lines shall be erected and maintained so the automatic controls produce a finished surface that does not vary from the prescribed cross section elevation by more than 0.04 foot from the gradeline established by the Engineer.

SECTION 304 PERMEABLE STABILIZED BASE COURSE.

Page 142

04-21-95

Add the following Section as Section 304:

**SECTION 304
PERMEABLE STABILIZED BASE COURSE**

304.01 DESCRIPTION.

This work consists of constructing a permeable stabilized base course mixed in a central plant and placed on a prepared subbase. The Contractor shall have the option of using Portland Cement or Asphalt Cement as a stabilizing agent to stabilize the base course.

304.02 MATERIALS.

A. **Aggregate.** The aggregate shall be a Class 7 aggregate as specified in Section 816.03.

Each lot of aggregate will be sampled by the Contractor at random locations determined by the Engineer. The Contractor will deliver the aggregate sample to the field lab. A lot is defined as one day's production if production is greater than 4,500 square yards per day. If production is less than 4,500 square yards per day, then a lot is as many days' production as necessary to place 4,500 square yards. If plan quantity is less than 4,500 square yards, a lot shall be equal to plan quantity. A day's production will not be split into more than one lot.

Three random samples will be taken, for each lot, by the Contractor at a location determined by the Engineer. The sampling procedures shall meet the requirements of AASHTO T-2. These samples will be tested and the material accepted if the average of the 3 samples meets the gradation specified. If the material from all 3 samples meets the gradation specified only one of the 3 samples will be tested from each

subsequent lot. If the sample tested does not meet the gradation requirements, the remaining 2 samples will be tested. The average gradation of these 3 samples will then be used to determine acceptance of the material. The testing of 3 samples per lot will continue until all 3 samples meet the gradation specified then only one of the 3 samples will be tested from each subsequent lot. When the aggregate does not meet the gradation specified, a reduction in the Contract Unit Price will be made. If the aggregate fails to meet the specified gradation on one or more sieves, the reduction will be the sum of the deductions as calculated below.

Unit Price Reduction: Percent of Deduction = 5 × percent of deviation from range limits.

If material is produced that deviates from the specified gradation for 2 consecutive lots incorporation of additional material into the work will not be allowed until the Contractor takes the necessary corrective action to meet the specifications.

The physical properties of the aggregate will be determined from three random samples taken from the stockpile for each lot of 10,000 tons or fraction thereof. If a fraction of a lot is less than 2,500 ton, it will be included with the previous lot of 10,000 tons. If the material from all three samples is within the specified limits, only one of the three samples will be tested from each subsequent lot. If at anytime the sample tested fails to meet the specified limits, the remaining 2 samples will be tested and the physical properties of each lot will be determined by the average of these 3 test results. The testing of three samples per lot will continue until all three samples are within the specified limits then only one of the three samples will be tested from each subsequent lot. If the average exceeds the specified limits for shale, the unit price for aggregate will be adjusted according to Section 302.06. If the average does not meet the specified limits for fractured faces, the Contractor shall correct the stockpile so the material meets specifications.

The L.A. Abrasion loss percentage will be determined on the basis of one composite aggregate sample taken and tested during the beginning of the aggregate stockpiling. If the aggregate source has been tested previously by the Department and the material is within the allowable limits, the tests for the L.A. Abrasion loss percentage will not be required.

B. Asphalt. The asphalt cement shall be an AC 20 asphalt meeting the requirements of Section 818.02 A.2.

The bitumen shall be added to the aggregate uniformly at a rate of 2 1/2% by weight of the mix.

If the daily cutoff for the asphalt cement, as determined on the Mix Bitumen Cutoff Report, deviates from the target percentage specified by more than 0.24 percentage points, the pay factor will be determined as specified in Section 408.05 B.1.

C. Portland Cement. The Portland Cement shall meet the requirements of Section 804.01.

The Portland Cement content shall be 200 pounds per cubic yard. Batching of the cement shall be according to Section 802.04 B. Aggregates and bulk cement shall be proportioned by automatic batching equipment according to Section 153.01 B.

304.03 EQUIPMENT.

Equipment shall meet the following:

Item	Section
General	151.01
Rollers	151.02 C
Material Hauling Equipment	151.03 B
Bituminous Pavers	151.04
Scales	151.07
Hot Bituminous Equipment	152
Roadbed Planer	153.06
P.C.C. Equipment	153

304.04 CONSTRUCTION REQUIREMENTS.

A. General.

1. **Subbase.** Before placing the permeable base, the subbase shall be trimmed to the required grade and cross section by a roadbed planer. The finished surface of the subbase shall not vary by more than 0.04 foot from the prescribed elevation.

A prime coat shall be applied to establish an impermeable layer below the permeable base. The prime coat shall be allowed to cure a minimum of 24 hours before the permeable base is placed.

2. **Finished Surface.** The surface of the permeable base shall be smooth and uniform, and shall not vary by more than 0.04 foot from the prescribed elevation. Trimming of the permeable base will not be permitted. Care shall be exercised to prevent contamination of the permeable base. Procedures that might produce fine material that would tend to clog or reduce drainage will not be permitted. Permeable base which, in the opinion of the Engineer, has been contaminated shall be removed and replaced at the Contractor's expense.
3. **Traffic.** Hauling on the permeable base will not be allowed. Traffic over the permeable base will be limited to the minimum necessary for succeeding or adjacent work. Damage to the permeable base shall be repaired promptly at the Contractors expense.
4. **Pavement Edge.** The outlet edge of the permeable base shall be kept open (daylighted) until the edge drain is placed so that water is free to exit.
5. **Placement.** The permeable base shall be placed in one lift at the specified thickness. The base will be placed with a mechanical spreader, except when placing the base in small areas that are not accessible to large equipment. In these areas the base may be hand placed and compacted with mechanical hand tampers.

If approved by the Engineer, the permeable base may be placed without the stabilizing agent in small areas that are formed by hand.

6. **Tolerance in Base Thickness.** Immediately after compaction of the permeable base, the thickness will be determined. The depth checks will be at random locations determined by the Engineer. Depth checks will be conducted at a frequency of two sets per 4,500 square yards. A minimum of 2 sets of depth checks will be conducted for areas less than 4,500 square yards.

A set of depth checks shall consist of placing three metal plates across the roadway at each random location. The plates shall be placed on top of the primed surface. The thickness will be determined by inserting a metal measuring device through the permeable base until the device contacts a metal plate. The depth of insertion shall be recorded.

If the permeable base placed has an average thickness in excess of that specified, additional payment will not be made. If the average pavement thickness is deficient by more than one inch, the base will be removed and replaced at the Contractors expense. If deficient by less than one inch in thickness, price adjustments will be made to the Contract Unit Price as provided in the following table:

Deficiency in Thickness (Inches)	Pay Factor
0.0 to 0.25	1.00
0.26 to 0.50	.90
0.51 to 0.75	.70
0.76 to 1.00	.50

B. Asphalt Stabilized Base.

1. **Material Production and Placement.** The permeable base shall be produced at a central hot mix plant according to Section 408.04 E and 408.04 F, paragraph one. The material produced shall be placed with a bituminous paver.
2. **Compaction.** Compaction of the permeable base shall be according to Section 302.04 E. except the roller shall be a 10 ton, double drum, steel wheeled roller. No vibration will be allowed. The Contractor is advised that it may be necessary to permit the permeable base to cool sufficiently before compaction rolling to prevent rutting and shoving. Cooling to 150°F. may be appropriate, but in no case shall the mix be less than 110°F. at time of compaction. Water may not be used to hasten the cooling process.
3. **Weather Limitations.** Weather limitations shall be as specified in Section 408.04 M.1.

C. Portland Cement Treated Base.

1. **Material Production.** The Permeable base shall be mixed at a stationary mixing plant capable of producing a uniform mixture and shall be equipped with feeding and/or weighing devices that are capable of proportioning the mixture as specified.

The water/cement ratio shall provide for 100% cement (paste) coverage of aggregate without significant runoff of the cement/water portion of the mix during transportation and placement. The intent is to add the minimum amount of water to obtain a uniform workable mix.

2. **Placement.** The cement stabilized base shall be placed with a slip form paver or a mechanical spreader capable of placing the material in one layer. The paver or spreader shall be equipped with automatic grade control that maintains the proper elevation at both sides by: (1) controlling the elevation of one side and the slope, or (2) controlling the elevation of each side independently. The grade reference shall be an erected string line or other approved method.

The cement stabilized base shall be consolidated with surface pan type vibrators. The frequency of the surface pan type vibrators shall not be less than 4000 impulses per minute, unless modified by the Engineer.

If the surface below the cement stabilized base is not primed, it shall be made uniformly moist prior to placing the base.

The cement stabilized base shall be allowed to cure a minimum of 48 hours before placement of the surface course. Exceptions may be made, with the Engineer's approval, in areas where immediate access is necessary to accommodate traffic.

Weather limitations shall be as specified in Section 602.03 G.3.

When placing the stabilized base at bridge ends, ramp tapers or other areas where placement is not practical with a mechanical spreader, the base material may be placed with a loader and compacted with a 10 ton steel wheeled roller in the static mode.

304.05 METHOD OF MEASUREMENT.

Permeable Stabilized Base Course. Permeable Stabilized Base shall be measured by the square yard placed, and accepted by the Engineer.

304.06 BASIS OF PAYMENT.

The accepted quantity of permeable stabilized base will be paid for at the contract price bid per square yard. The price shall be full compensation for all materials (including the asphalt or portland cement binder), equipment, labor, and incidentals required to construct this item of work as specified.

407.02 MATERIALS.

Page 161

02-03-95

Delete the last sentence in Section 407.02 A., Bitumen, and insert the following:

Bitumen will be conditionally accepted at the Project and sampled by the Contractor according to Department procedures.

407.03 EQUIPMENT.

Page 161

02-11-94

Add the following to the equipment list in Section 407.03:

Item
Combination Roller

Section
151.02 E

407.04 CONSTRUCTION REQUIREMENTS.

Page 162

11-17-95

Insert the following paragraph between the Subtitle, CONSTRUCTION REQUIREMENTS, and Section A:

The Contractor shall have at least one person in charge of quality control on the project at all times. This person shall be qualified for Process Control and Field Verification as outlined in the NDDOT Bituminous Qualification Program. If the Prime Contractor sublets any portion of the Contract, including aggregate production, to a Subcontractor, the Subcontractor shall have a person qualified for Process Control and Field Verification on the Project. If the Subcontractor does not have a qualified person, the Prime Contractor's qualified person shall be on the Project and be in charge of quality control.

407.04 CONSTRUCTION REQUIREMENTS.

Page 162

03-25-94

02-03-95

04-21-95

Delete Section 407.04 D, Sample Submission, in its entirety and insert the following:

Add the following to Section 709.03:

E. Geotextile Reinforcement Fabric.

When placing the fabric, the geotextile shall be unrolled in line with the placement of the new aggregate. The fabric shall not be dragged across the subgrade. Fabric widths shall be used so overlaps of parallel rolls occur at the centerline and at the shoulders. Overlaps shall not be placed along the wheel path locations.

The fabric shall be overlapped a minimum of 30 inches at all splices or joints. In lieu of joint overlapping, multiple fabric pieces may be sewed if the seam produces 90% of the fabric tensile strength. The seam shall be sewn with a "J" seam as specified above. The 30-inch overlap at the end of the roll shall be in the direction of the aggregate placement so the previous roll laps over the subsequent roll.

The first lift above the reinforcement fabric shall have a minimum lift of 12 inches before compaction.

Small dozer equipment or front end loaders with low ground pressures shall be used to spread the cover material.

709.04 METHOD OF MEASUREMENT.

Add the following to Section 709.04:

D. Geotextile Reinforcement Fabric. The reinforcement fabric shall be measured by the actual surface area covered to the nearest square yard. No allowance will be made for overlaps.

709.05 BASIS OF PAYMENT.

Add the following to section 709.05:

Pay Item	Unit
Geotextile Reinforcement Fabric	Square Yard

714 CULVERTS, STORM DRAINS AND UNDERDRAINS.

Delete the title of Section 714 and insert the following:

SECTION 714

CULVERTS, STORM DRAINS, EDGE DRAINS, AND UNDERDRAINS

714.01 DESCRIPTION.

Delete Section 714.01 in its entirety and insert the following:

This work consists of installing culverts, storm drains, edge drains, and underdrains designed to intercept and carry off surface or underground water.

Culverts, storm drains, edge drains, and underdrains of the various types and sizes specified will, at times, be referred to as pipe or conduit in these Specifications.

714.02 MATERIALS.

Delete item "Metallic (Zinc or Aluminum) Coated Corrugated Steel Culverts" in Section 714.02 A and insert the following:

"Metallic (Zinc or Aluminum) Coated Corrugated Steel Culverts, Underdrains, and Storm Drains"

Add the following to Section 714.02:

E. Edge Drains.

Materials shall meet the following:

Item.	Section
Perforated, Corrugated, P.E. Pipe	830.03 A.5
PVC Discharge Pipe	830.03 A.4
Geotextile Separation Fabric	709.02
Trench Backfill	
Permeable Trench Backfill Cl.2	816.03
Permeable Base Aggr. Cl.7	816.03
Size 4 or 5 Concrete Aggregate*	816.02
Concrete Sand*	816.01
Class 43 Chips*	816.03

* Sieve analysis only.

714.03 CONSTRUCTION REQUIREMENTS.

Page 350

09-03-93

Delete the first paragraph of Section 714.03 A. 6. in its entirety and replace with the following:

6. **Backfilling for Pipe Installed in Embankments:** After installing the pipe on the required bedding, suitable backfill shall be placed along each side of the pipe in layers not exceeding 12 inches. Each layer shall be compacted to the required density. If a specified density is not required, compaction shall be according to Section 203.02 l.

714.03 CONSTRUCTION REQUIREMENTS.

Page 351

03-17-95

04-21-95

06-16-95

Add the following to Section 714.03:

- E. Edge Drains.** Edge Drains shall be constructed along the pavement edge as shown on the Plans. The drains shall be outletted at approximate intervals of 250 feet and at low points in the flow line of the edge drain.

The drains shall be placed by a machine trencher capable of cutting the trench, lining the trench with a geotextile fabric, and laying the pipe in a continuous operation. The drains shall be placed at a minimum grade of 0.2 percent. Laser grade control will be required on the trenching machine whenever the pipe grades do not follow the pavement grades at a constant depth. The trenching equipment shall be designed and operated so the excavated material does not fall back into the trench. The excavated trench material shall be disposed of by the contractor.

The trench backfill shall be compacted with a vibratory shoe compactor narrower than the trench, but not more than 2 inches less than the trench width. The trench backfill shall be compacted adequately to ensure that additional settlement will not occur.

When edge drains are installed adjacent to a permeable base material, the trench shall be wrapped with a Type B geotextile separation fabric. The fabric shall be pinned directly below the flow line of the permeable base material so the flow of water to the drain is not impeded. Concrete sand will not be used for trench backfill on projects using a permeable base material.

When edge drains are installed on a project with a non-permeable base material, the PE pipe shall be enclosed in a geotextile fabric sock. The Contractor may elect to use a Type A or Type B geotextile separation fabric for the sock.

Edge drains that outlet to the ditch shall be constructed concurrently with the longitudinal edge drains and laid at right angles to the roadway centerline. The discharge pipe shall be a PVC pipe laid at a minimum

grade of 2%. The connection to the edge drain pipe shall be made with a non-perforated PE pipe placed with a 3-foot radius. Two drains coming together at a low point shall be connected to separate discharge pipes. The discharge trenches shall be constructed similar to the drains, but shall be backfilled with the existing soil. Headwalls shall be installed a minimum of 6 inches above the ditch grade. The discharge pipe shall be inserted and coupled to the headwall with grout. The uppermost point of the headwall shall be placed flush with the roadway inslope. The inslope shall be shaped to conform to the sides and toe of the headwall. The headwall and rodent screen shall be installed at the same time the outlet pipe is installed.

Each headwall shall be provided with a rodent screen that fits snugly into the headwall so mice and other rodents are unable to enter the drain. The rodent screens must be removable, the Contractor will not be permitted to grout the screens into place.

Edge drains that outlet to a storm sewer system shall be coupled to the inlet by use of grout, rubber or plastic gaskets, or by a gasket joint inserted into a thermoplastic coupling cast into the inlet. The connections to the storm sewer shall be made concurrently with the installation of the drain. The cost of the connections to the storm sewer shall be incidental to the cost of the edge drains.

Ends of the drainage line where outlets are not required shall be capped.

All joints shall be connected securely according to the manufacturer's recommendations.

Construction equipment will not be allowed on the edge drain until it is properly protected.

714.04 METHOD OF MEASUREMENT.

Page 351

03-17-95

Add the following to Section 714.04:

E. Edge Drains. Edge drains will be measured by the Linear Foot of "Edge Drain Permeable Base" or "Edge Drain Non-Permeable Base" installed and accepted by the Engineer. The Contract Unit Price bid shall include all costs for trenching, geotextile fabric, trench backfill, compaction, caps, manhole connections, and other associated work.

The headwalls will be measured by the number of "Headwalls, Precast Concrete, 4 In." installed and accepted by the Engineer. The Contract Unit Price bid shall include payment for the headwall, the discharge pipe, the 3 foot radius pipe connection, trenching, backfilling, compaction, caps, rodent screen, connections, and other associated work.

714.05 BASIS OF PAYMENT.

Page 352

03-17-95

Add the following pay items to Section 714.05:

Pay Item	Pay Unit
Edge Drain Permeable Base	Linear Foot
Edge Drain Non-Permeable Base	Linear Foot
Headwalls, Precast Concrete, 4 In.	Each

714.05 BASIS OF PAYMENT.

Page 352

03-17-95

Delete the last three paragraphs of Section 714.05 and insert the following:

Unless otherwise specified, excavation for culverts, storm drains, underdrains, and edge drains, including excavation below flow line grade and excavation for imperfect trench, bedding, and backfill will not be paid for but shall be incidental to the pipe item. Disposal of unsuitable material will not be paid for but shall be incidental to the pipe item.

Geotextile fabric used with underdrains and edge drains will not be paid for separately, but will be incidental to the pipe items.

Granular fill or trench backfill used with underdrains and edge drains will not be paid for separately, but will be incidental to the pipe items.

Appendix C

**Experimental Project # ND 95-02
Crushed PCC for Drainable Base**

Evaluation Date:
October 18, 1999

Evaluated by:
T. Bold
M. Marquart

Base Material: 100% Salvaged Crushed PCC

Location of Edge Drain (Measured Length)	Leachate / Sediment	Water in System	Condition of Headwall	Condition of Road Surface
Sta. 2137+50L (140')	None, signs of drainage	Dry	Excellent, grass clippings	Corner cracking of panels
Sta. 2140+xxL (100')	Some fine silt, clay	Dry	Excellent, grass clippings	Corner cracking, spalling of panels
Sta. 2160+60L (160')	None, signs of drainage	1-1 1/2" Water in Pipe	Excellent	Corner cracking, spalling of panels
Sta. 2162+50L (180')	None, signs of drainage	1/2" water in pipe, signs of drainage	Excellent	Edge cracking-spalling/ corner cracking (damage where shoulder meets driving lane)

Notes:

- Frequent Corner Cracking
- Spalling of Cracks
- Breaking up of Corners

Base Material: 50 - 50 Blend (50% Crushed PCC - 50% Virgin Material)

Location of Edge Drain (Measured Length)	Leachate / Sediment	Water in System	Condition of Headwall	Condition of Road Surface
Sta. 2004+75L (160')	Dried material on 1/2 of pipe wall	Damp	Excellent	Some corner cracking & spalling
Sta. 2068+50L (160')	Fine soil deposits	Generally damp with standing water	Excellent, grass clippings	No corner cracking. Edge spalls. transverse cracks in shoulder.
Sta. 2073+00L (140')	Dried material on pipe wall	Damp	Excellent, grass covering headwall	Corner cracking, spalling. Transverse cracks in shoulder.

Notes:

- Fewer Corner Cracks in Superelevation Section (MP 178)
- Sta. 2004+75L - Dent in Pipe 90' from Headwall, Pipe crushed 164' from Headwall (crushed top-down, 3/4" gap for moisture / material passage.)

Base Material: 100% Virgin Aggregate

Location of Edge Drain (Measured Length)	Leachate / Sediment	Water in System	Condition of Headwall	Condition of Road Surface
Sta. 1852+45L (160')	Dried material on 1/2 of pipe	Damp	Excellent	Some corner cracking
Sta. 1875+35L (160')	Fine soil deposits	Damp	Headwall Missing, no rodent screen, pipe end open.	Some edge cracking, spalling, and corner cracking
Sta. 1927+80L (140')	Fine sediment in pipe, volume increases near outlet.	Damp	Excellent	Edge cracking, spalling

Notes:

- Sta. 1927+80L, Dents in pipe @ 56' and 145'; fine soils, volume increases near headwall, decreases to none at 150'.
- Sta. 1875+35L - Headwall missing, pipe open to rodents.

**Experimental Project # ND 95-02
Crushed PCC for Drainable Base**

Evaluation Date:
September 11, 2001

Evaluated by:
B. Fuchs
M. Marquart

Base Material: 100% Salvaged Crushed PCC

Location of Edge Drain (Measured Length)	Leachate / Sediment	Water in System	Condition of Headwall	Condition of Road Surface
Sta. 2137+50L (140')	1/2 depth of pipe is waterline	Dry	Excellent, Dirt and grass clippings	Edge spalling and minor corner breaks
Sta. 2140+00L (100')	1/3 depth of pipe is waterline	Dry	Excellent, Dirt in trough	Edge/corner spalling and separation at Shoulder
Sta. 2160+60L (160')	1/3 to 1/2 depth of pipe is waterline	Dry	Excellent, Dirt in trough	Transverse cracking, edge spalling and separation at Shoulder
Sta. 2162+50L (180')	1/3 to 1/2 depth of pipe is waterline	Dry	Excellent, Dirt and grass clippings	Edge cracking-spalling/corner cracking (damage where shoulder meets driving lane)
Notes:				

Base Material: 50 - 50 Blend (50% Crushed PCC - 50% Virgin Material)

Location of Edge Drain (Measured Length)	Leachate / Sediment	Water in System	Condition of Headwall	Condition of Road Surface
Sta. 2004+75L (160')	1/2 depth of pipe is waterline	Dry	Excellent, grass covering headwall	Some corner cracking & spalling. Shoulder separation
Sta. 2068+50L (160')	1/3 depth of pipe is waterline	Dry	Excellent, grass clippings	Edge spalls. transverse cracks in shoulder. Shoulder Separation
Sta. 2073+00L (140')	1/2 depth of pipe is waterline	Dry	Excellent, grass covering headwall	Corner cracking, spalling. Transverse cracks in shoulder. Shoulder Separation.
Notes:				
- Sta. 2004+75L - Dent in Pipe 90' from Headwall, Pipe crushed 164' from Headwall (previous evaluation) (crushed top-down, 3/4" gap for moisture / material passage.)				

Base Material: 100% Virgin Aggregate

Location of Edge Drain (Measured Length)	Leachate / Sediment	Water in System	Condition of Headwall	Condition of Road Surface
Sta. 1852+45L (160')	1/2 depth of pipe is waterline	Dry	Excellent, Dirt in trough	Some edge cracking, spalling, corner cracking, transverse shoulder cracking.
Sta. 1875+35L (160')	1/3 depth of pipe is waterline	Dry	Headwall Missing, no rodent screen, pipe end open.	Some edge cracking, spalling, and corner cracking
Sta. 1927+80L (140')	Fine sediment in pipe, volume increases near outlet.	Dry	Excellent, Dirt and grass clippings	Edge cracking, spalling. Shoulder separation.
Notes:				
- Sta. 1875+35L - Headwall missing, pipe open to rodents.				