

1. Report No. MR 2011-01	2. Report Date February 2020	3. Contract No. N/A	4. Project No. SER-2-003(018)008
5. Title and Subtitle  Evaluation of "Safety Edge" on Asphalt Pavement		6. Report Type  Work Plan <input type="checkbox"/> <b>Construction</b> <input type="checkbox"/> Evaluation <input type="checkbox"/> <u>Final</u> <input checked="" type="checkbox"/>	7. Project No. MER-2-011(029)041 8. Project No. MER-2-011(030)045 9. Project No. MER-2-013(044)249 10. Project No. MER-2-046(041)014
11. Author(s)/Principal Investigator(s) TJ Murphy			
12. Performing Organization Name and Address  NDDOT M+R <input checked="" type="checkbox"/> North Dakota DOT NDDOT OTHER* <input type="checkbox"/> Materials and Research Division NDSU <input type="checkbox"/> 300 Airport Road UND <input type="checkbox"/> Bismarck ND 58504-6005 UGPTI <input type="checkbox"/> OTHER* <input type="checkbox"/> *see supplementary notes		13. Sponsoring Agency Name and Address  North Dakota DOT Materials and Research Division 300 Airport Road Bismarck ND 58504-6005	
14. Supplementary Notes			
15. Abstract <b>Purpose and Need</b> The focus of FHWA's "Every Day Counts (EDC) "initiatives are to identify and deploy innovative techniques targeted at shortening project delivery, enhancing the safety of roadways, and protecting the environment.  Drivers who drift from the roadway need a method to safely transition back onto the paved surface. It is reported that some states construct their asphalt pavements using a vertical edge at the outside edges of the pavement. An errant driver leaving the paved surface may find it difficult to return to the paved surface, and the attempt may result in a serious accident. Soil or granular materials may be brought up to the top of the pavement to create a transition; however, erosion or vehicular damage to this area may re-expose the vertical pavement edge – creating a maintenance and ultimately safety issue.  The construction of a wedge-shaped transition at the pavement edge has been shown to be effective in allowing an errant driver to safely return to the paved surface. FHWA sponsored research has shown the 30-degree angle of the "Safety Edge" to be the optimal angle to allow drivers to return to the roadway safely.  <b>Objective</b> The objective of this project is to evaluate the construction of the <i>Safety Edge</i> using a FHWA provided "safety shoe" device that forms and consolidates the pavement edge.  <b>Scope</b> The NDDOT Design Division has identified five asphalt paving projects scheduled for construction in the Valley City District during the 2011-2012 seasons. Requirements for the construction of the <i>Safety Edge</i> and use of the "safety shoe" were incorporated into the bid and construction documents by plan details and special provision. The "safety shoe" being provided by FHWA is the <i>Ramp Champ</i> manufactured by Advant-Edge Paving Equipment, LLC  <b>Summary</b> Over the 2011-2012 construction seasons NDDOT has constructed five projects totaling 3.795 miles of roadway with the 30° Safety Edge design. The Pavement Ramp Champ device was used on all 5 projects by the same contractor BSP to successfully produce a safe traversable pavement edge. Average Angle produced with the Ramp Champ device on all five projects combined was 26.2° with a standard deviation of 4.0°. The three control projects were emergency grade raises constructed allowing the contractor to install the edge by their own methods. The contractor chose to use a slough box. Average Angle produced with this method was 20.9° with a standard deviation of 4.5°. Both methods of producing the 30° Safety edge had comparable results.			
16. Key Words  Ramp Champ Safety Edge Pavement Edge EDC(Every Day Counts)	17. Distribution Statement No restrictions. This document is available by clicking this link:  North Dakota Department of Transportation Materials and Research Division: 300 Airport Road Bismarck, ND 58504-6005		18. No. of Pages 85  19. File type Pdf

**NORTH DAKOTA DEPARTMENT OF  
TRANSPORTATION**

**MATERIALS AND RESEARCH  
DIVISION**



**Evaluation of the “Safety Edge” on Asphalt Pavement**

MR 2011-01

Final Evaluation

February 2020

**NORTH DAKOTA DEPARTMENT OF TRANSPORTATION**  
BISMARCK, NORTH DAKOTA  
[www.dot.nd.gov](http://www.dot.nd.gov)

**DIRECTOR**  
William Panos

**MATERIALS AND RESEARCH DIVISION**  
Matt Linneman, P.E.



Experimental Study MR 2011-01

# **Evaluation of the “Safety Edge” on Asphalt Pavement**

## **Final Evaluation**

February 2020

Written by  
TJ Murphy, PE



## **Disclaimer**

The contents of this report reflect the views of the author or authors who are responsible for the facts and the accuracy of the data presented herein. The contents do not reflect the official views of the North Dakota Department of Transportation or the Federal Highway Administration. This report does not constitute a standard, Specification, or regulation.



**Table of Contents**

[Purpose and Need](#) ..... [1](#)

[Objective](#) ..... [3](#)

[Scope](#) ..... [4](#)

[Location](#)..... [5](#)

[Design](#) ..... [5](#)

[Evaluation](#) ..... [6](#)

[Construction](#) ..... [6](#)

[1<sup>st</sup> Evaluation](#)..... [12](#)

[2<sup>nd</sup> Evaluation](#)..... [20](#)

[Summary](#)..... [28](#)

[Appendix A: Typical Section with Safety Edge](#)

[Appendix B: Special Provision- SP\(636\)08; with Ramp Champ and Universal Mounting Bracket User Manual.](#)



# Final Evaluation

## Evaluation of the “Safety Edge” on Asphalt Pavement

### MR 2011-01

#### Purpose and Need

##### FHWA Every Day Counts (EDC)

The focus of FHWA’s “Every Day Counts (EDC)” initiatives are to identify and deploy innovative techniques targeted at shortening project delivery, enhancing the safety of roadways, and protecting the environment.

Drivers who drift from the roadway need a method to safely transition back onto the paved surface. It is reported that some states construct their asphalt pavements using a vertical edge at the outside edges of the pavement. An errant driver leaving the paved surface may find it difficult to return to the paved surface, and the attempt may result in a serious accident. Soil or granular materials may be brought up to the top of the pavement to create a transition; however erosion or vehicular damage to this area may re-expose the vertical pavement edge – creating a maintenance and ultimately safety issue.

The construction of a wedge shaped transition at the pavement edge has been shown to be effective in allowing an errant driver to safely return to the paved surface. FHWA sponsored research has shown the 30 degree angle of the “Safety Edge” to be the optimal angle to allow drivers to return to the roadway safely.

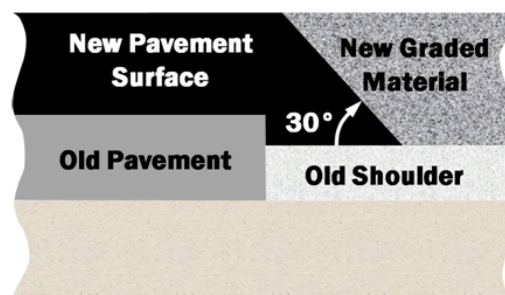

FHWA’s research has shown that asphalt paving equipment can be retrofitted with devices that will create the transition as part of the paving operation. The “safety shoe” is a special edging device that can be used to create the desired 30 degree slough angle. Asphalt paving contractors can install the “safety shoe” on new or existing resurfacing equipment. In addition to

forming the 30 degree wedge, it is reported that the “safety shoe” consolidates the asphalt material; thereby improving safety and contributing to longer pavement life – relative to the pavement edge.

FHWA promotes bringing the soil or granular material up to the top edge of the pavement as a “best practice” to provide for the safest pavement edge. Research by some states has indicated that the wedge shape created by the *Safety Edge*, no longer requires it.

As stated in the FHWA *Safety Edge* brochure (Publication Number: FHWA-SA-10-034), “FHWA’s goal is to accelerate the use of the *Safety Edge* technology, working with States to develop specifications and adopt this pavement edge treatment as a standard practice on all new paving and resurfacing projects.”

#### NDDOT Design and Construction Practices

NDDOT’s current design practice incorporates the option of constructing a 4:1 transition at the pavement edge or a 30 degree transition – (similar to the FHWA proposed *Safety Edge*). Which option is used is dependent on roadway classification, in-slope design, and shoulder material type. These options and the selection criteria are defined in the *NDDOT Design Manual, Section I-06 – Design Philosophy, Investment Strategy, and Guides*.

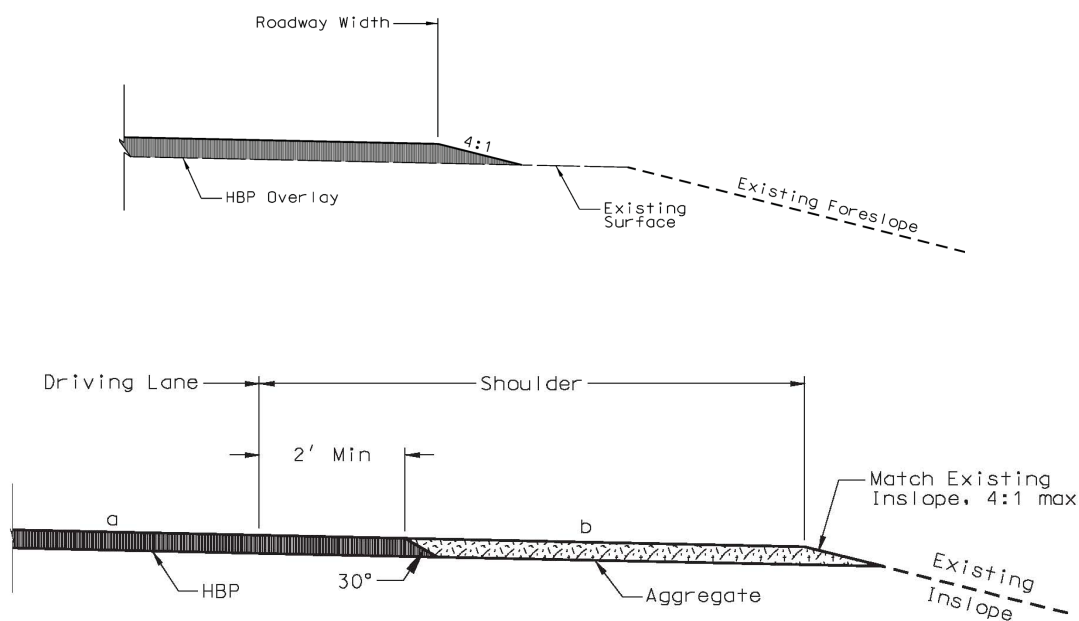

Typical practices by asphalt paving companies have been to construct the transition at the pavement edge using a slough box attached to the paving equipment pictured below. When the 30 degree alternate is used, soil or granular materials are brought up level to the top of the pavement edge.



**Photo 1 : Typical ND contractor slough box paving operation.**

NDDOT Districts prefer the 4:1 transitions from a safety and maintenance perspective. Typical District and Design Division comments are:

- Although the *Safety Edge* is a safety improvement over a paved vertical edge, the vertical edge is not allowed by the NDDOT. The current NDDOT design of 4:1 transitions is more recoverable than the 30 degree slough of the *Safety Edge*.
- Generally speaking, the NDDOT has not experienced deterioration of the pavement edge due to poor consolidation from insufficient compaction of the 4:1 or 30 degree slough.
- The Districts voiced concerns when using the NDDOT 30 degree slough, erosion of the soil or granular material by precipitation events or errant vehicles may be an issue. This may create an increased need for unscheduled maintenance and increased maintenance costs.

#### Field Evaluation

Local FHWA Division personnel have suggested that a comparison of NDDOT's current

practices to the Safety Edge could provide valuable data. Recognizing the importance of a recoverable pavement edge in safe road design, the NDDOT has agreed to participate in a field evaluation of the design and equipment used to construct the FHWA *Safety Edge* as compared to NDDOT's current design and construction practice.

### **Objective**

The objective of this project is to evaluate the construction of the *Safety Edge* using a FHWA provided "safety shoe" device that forms and consolidates the pavement edge.

It is proposed that by constructing NDDOT demonstration projects using the *Safety Edge* design, the NDDOT and paving contractor(s) will have an opportunity to use the "safety shoe". M&R will observe the paving process, and evaluate the performance and future maintenance requirements of pavements constructed with the *Safety Edge*. The project will compare a pavement edge constructed using the safety shoe compared to a pavement edge constructed using current NDDOT practices.

### **Scope**

The NDDOT Design Division has identified five asphalt paving projects scheduled for construction in the Valley City District during the 2011-2012 seasons. The following projects have been designed with the *Safety Edge* as the required pavement edge treatment:

SER-2-003(018)008	PCN 18945
MER-2-011(029)041	PCN 19110
MER-2-011(030)045	PCN 19111
MER-2-013(044)249	PCN 19114
MER-2-046(041)014	PCN 19122

Requirements for the construction of the *Safety Edge* and use of the "safety shoe" were incorporated into the bid and construction documents by plan details and special provision. The "safety shoe" being provided by FHWA is the *Ramp Champ* manufactured by Advant-Edge Paving Equipment, LLC. A copy of the *Ramp Champ User Manual* was provided as part of the bid documents (Appendix A).

**Location**

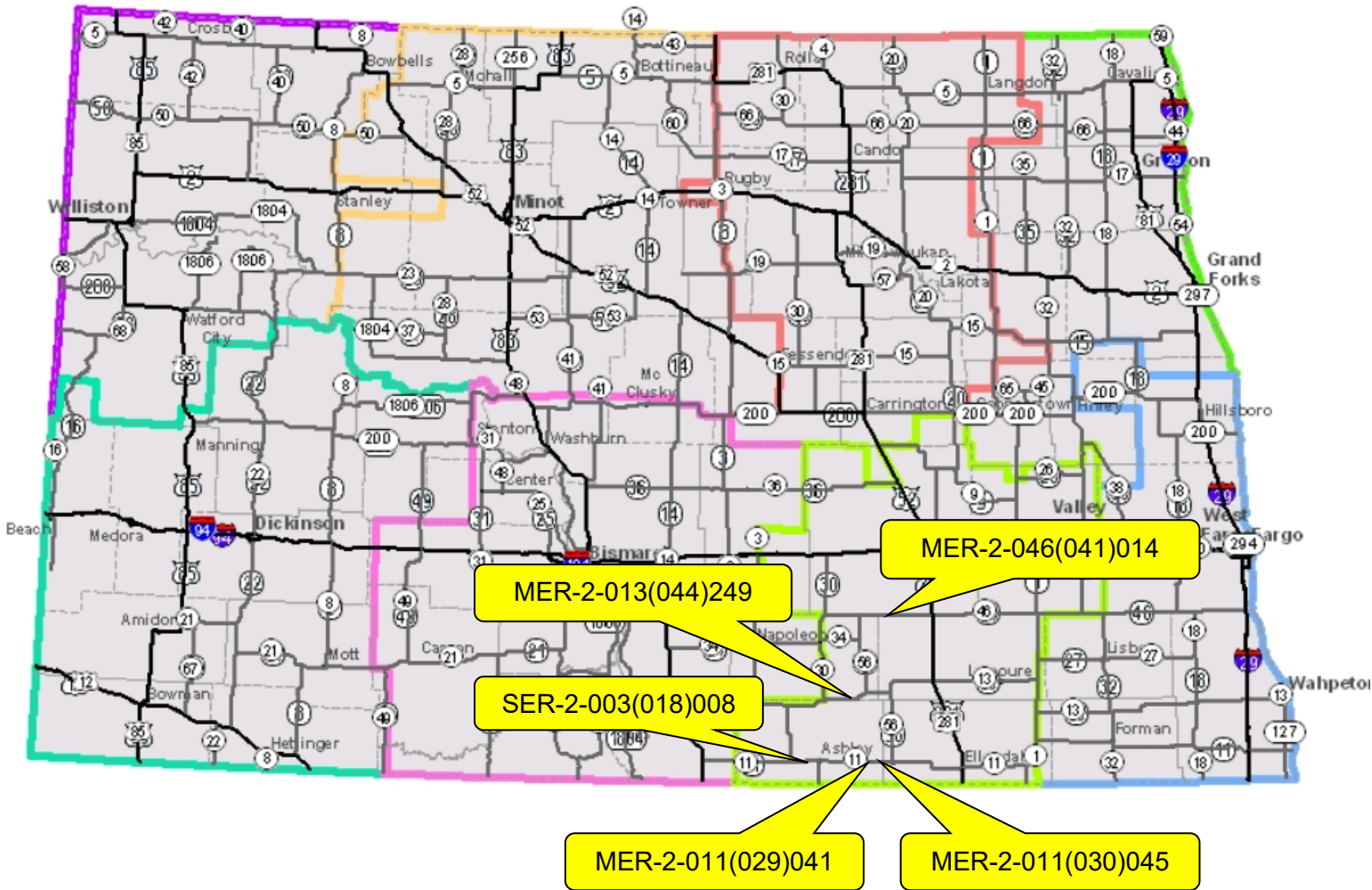

The construction of the *Safety Edge* demonstration projects will be in conjunction with the above mentioned projects in the Valley City District.

**Design**

The projects chosen for this research are emergency grade raises to be constructed over the 2011 and 2012 construction seasons. The roadways will be raised and paved with HBP using the Ramp Champ “Safety Edge” treatment in accordance with the corresponding special provision to see the full special provision please see Appendix A. Along with the above mentioned projects three additional projects will be constructed allowing the contractor to construct the 30° edge using a method to best suit their paving operation and a typical 4:1 edge.

---

## Evaluation

Staff members from the Materials & Research Division will be onsite to observe and document the construction process with photographs and interviews from NDDOT project engineer and contractor personnel.

The *Safety Edge* locations will be observed and evaluated semi-annually over a five year period using the following criteria:

Pavement Condition – Observe and compare the physical condition of the pavement materials used to construct the *Safety Edge* relative to nearby projects constructed using typical NDDOT design and construction practices.

Maintenance Requirements – Observe and compare the physical condition of the soil or granular material that has been brought up to the top of the pavement edge. This will be accomplished by visual site observations and through interviews with District maintenance personnel.

The field evaluation will be conducted during the fall. Annual reports will be produced during the evaluation. A final report documenting the outcome of the evaluation will be written by M&R after the data has been assembled and analyzed.

## Construction

The five emergency grade raise projects selected for this research are in the Valley City District and summarized below. The Ramp Champ “safety shoe” was used to construct these projects.

- **SER-2-003(018)008**

Project SER-2-003(018)008 was an emergency grade raise 0.284 Miles long designed and administered by the Valley City district. The construction of the Safety Edge was performed in July 2011 by Border States Paving, Inc. (BSP).

- **SER-2-011(029)041**

Project SER-2-011(029)041 was an emergency grade raise 0.735 Miles long designed and administered by the Houston Engineering. The construction of the Safety Edge was performed in August 2012 by BSP, Inc.

- **SS-2-011(030)045**

Project SER-2-011(029)041 was an emergency grade raise 0.814 Miles long designed and administered by the Houston Engineering. The construction of the Safety Edge was performed in July 2012 by BSP, Inc.

- **SER-2-013(044)249**

Project SER-2-013(044)249 was an emergency grade raise 0.532 Miles long designed by Apex Engineering Group and administered by the Bartlett & West Engineering. The construction of the Safety Edge was performed in August 2012 by BSP, Inc.

- **SER-2-046(041)014**

Project SER-2-046(041)014 was an emergency grade raise 1.43 Miles long designed by Apex Engineering Group and administered by the Bartlett & West Engineering. The construction of the Safety Edge was performed in August 2012 by BSP, Inc.

The three control sections were emergency grade raises in the Valley City District and are summarized below. The pavement edge on these projects was constructed using “typical” ND contractor method and equipment. The “safety shoe” was not used.

- **SER-2-011(027)047**

Project SER-2-011(027)047 was an emergency grade raise 0.585 miles long designed and administered by NDDOT. The construction of the typical 4:1 edge was performed in August 2010 by BSP, Inc.

- **SER-2-030(013)007**

Project SER-2-030(013)007 was an emergency grade raise 0.767 miles long designed and administered by NDDOT. The construction of the 30° edge was performed in August 2012 by BSP, Inc.

- **SER-2-056(029)007**

Project SER-2-056(029)007 was an emergency grade raise 0.777 miles long designed and administered by NDDOT. The construction of the 30° edge was performed in July 2012 by BSP, Inc.

Construction of the safety edge on the experimental (research) sections was achieved by attaching the ramp champ paving shoe to the screed pictured below.



**Photo 2: Ramp Champ paving shoe attached to paver.**

The angle produced by the Ramp Champ paving shoe was measured before and after the compaction effort for SER-2-003(018)008 & MER-2-011(030)045 the results are summarized in the table below.

**Table 1: Uncompact edge compared to compacted edge.**

Project	Uncompact Edge	Compacted Edge	AVG. Change (+,-)
SER-2-003(018)008	22.3°	23.3°	2.5°
MER-2-011(030)045	27.6°	26.4°	2.5°

Compaction of the edge was achieved with single smooth drum vibratory roller acting as the breakdown roller followed by a double smooth drum vibratory roller. The breakdown roller played a key role in dictating the resulting edge angle. In photo #3 the breakdown roller is compacting a tender safety edge manipulating the initially produced edge.



**Photo 3: Breakdown roller compacting the safety edge.**

Edge measurements were collected for each project post compaction with a digital angle finder. The measurement device is pictured below.



**Photo 4: Measurement device.**

Each project had measurements taken at least every 200' on both sloughs. Project averages and standard deviations are summarized in the table 2.

**Table 2: Safety Edge project averages.**

Project	EB Average	WB Average	STD DEV
SER-2-003(018)008	21.8°	25.1°	4.9°
MER-2-011(029)041	24.4°	28.1°	4.0°
MER-2-011(030)045	26.4°	26.4°	2.6°
MER-2-013(044)249	26.2°	28.3°	3.9°
MER-2-046(041)014	28.2°	27.2°	4.9°

Once paving was complete the adjacent unpaved material was re-graded flush with the top of the new HBP. The final edge is pictured below.



**Photo 5: Finished safety edge on project #SER-2-003(018)008.**

## **1<sup>st</sup> Evaluation**

In the fall of 2013 M&R performed a field evaluation of the five safety edge projects and three control projects. M&R investigated both safety edge projects and the control projects for aggregate loss and durability issues. M&R found the pavement condition of the safety edge and control edge to be performing satisfactory with the exception of project SER-2-003(018)008 which had a localized issue in initial HBP quality that required repair.



**Photo 6: Project SER-2-003(018)008 localized HBP shoulder repair.**

Site photos illustrating the condition of the five safety edge projects along with the three control projects are featured below.



**Photo 7: (ND 3, RP 8) - 30° Safety Edge Fall 2013 North Shoulder Facing East**



**Photo 8: (ND 3, RP 8) - 30° Safety Edge Fall 2013 South Shoulder Facing East**



**Photo 9: (ND 11, RP 41) - 30° Safety Edge South Shoulder Facing East**



**Photo 70: (ND 11, RP 41) - 30° Safety Edge North Shoulder Facing East**



**Photo 81: (ND 11, RP 45) - 30° Safety Edge North Shoulder Facing East**



**Photo 92 :( ND 11, RP 45) - 30° Safety Edge South Shoulder Facing East**



**Photo 103 :( ND 13, RP 249) - 30° Safety Edge North Shoulder Facing West**



**Photo 114: (ND 13, RP 249) - 30° Safety Edge South Shoulder Facing West**



**Photo 125: (ND 46, RP 13) - 30° Safety Edge South Shoulder Facing East**



**Photo 136: (ND 46, RP 13) - 30° Safety Edge South Shoulder Localized Riling on Super-Elevation**



**Photo 147: (ND 11, RP 47) Control, 4:1 NDDOT Standard South Shoulder Facing East**



**Photo 158: (ND 30, RP 7) Control 30° Contractor Constructed East Shoulder Facing North**



**Photo 19: (ND 30, RP 7) Control 30° Contractor Constructed West Shoulder Facing North**



**Photo 160: (ND 56, RP 7) Control 30° Contractor Constructed East Shoulder Facing North**



**Photo 171: (ND 56, RP 7) Control 30° Contractor Constructed West Shoulder Facing North**

## **2<sup>nd</sup> Evaluation**

In the fall of 2014 M&R performed a field evaluation of the five safety edge projects and three control projects. M&R investigated both safety edge projects and the control projects for aggregate loss and durability issues. M&R found the pavement condition of the safety edge and control edge to be performing satisfactory. Over the 2014 construction season chip seals had been performed as a preventative maintenance on most of the safety edge and control segments this resulted in an increase of pea sized aggregate over the shoulder. Residual aggregate from the chip seal operation negated any of shoulder aggregate attrition that had occurred. Site photos are included illustrating the conditions of the five safety edge and three control projects.



Photo 22: (ND 3, RP 8) - 30° Safety Edge Fall 2014 North Shoulder Facing East



Photo 23: (ND 3, RP 8) - 30° Safety Edge Fall 2014 South Shoulder Facing East



**Photo 24: (ND 11, RP 41) - 30° Safety Edge 2014 South Shoulder Facing East**



**Photo 25: (ND 11, RP 41) - 30° Safety Edge 2014 North Shoulder Facing East**



**Photo 26: (ND 11, RP 45) - 30° Safety Edge 2014 North Shoulder Facing East**



**Photo 27 : ( ND 11, RP 45) - 30° Safety Edge 2014 South Shoulder Facing East**



Photo 28 :( ND 13, RP 249) - 30° Safety Edge 2014 North Shoulder Facing West



Photo 29: (ND 13, RP 249) - 30° Safety Edge 2014 South Shoulder Facing West



**Photo 30: (ND 46, RP 13) - 30° Safety Edge 2014 South Shoulder Facing East**



**Photo 31: (ND 46, RP 13) - 30° Safety Edge 2014 North Shoulder Facing East**



**Photo 32: (ND 11, RP 47) 2014 Control, 4:1 NDDOT Standard South Shoulder Facing East**



**Photo 32: (ND 30, RP 7) 2014 Control 30° Contractor Constructed East Shoulder Facing North**



**Photo 33: (ND 30, RP 7) 2014 Control 30° Contractor Constructed West Shoulder Facing North**



**Photo 34: (ND 56, RP 7) 2014 Control 30° Contractor Constructed East Shoulder Facing North**



**Photo 35: (ND 56, RP 7) 2014 Control 30° Contractor Constructed West Shoulder Facing North**

### **Final Evaluation**

In the fall of 2017 M&R performed a field evaluation of the five safety edge projects and three control projects. M&R investigated both safety edge projects and the control projects for aggregate loss and durability issues. M&R found the pavement condition of the safety edge and control edge to be performing satisfactory. Over the 2014 construction season chip seals had been performed as a preventative maintenance on most of the safety edge and control segments this resulted in an increase of pea sized aggregate over the shoulder. Residual aggregate from the chip seal operation negated any of shoulder aggregate attrition that had occurred. Site photos are included illustrating the conditions of the five safety edge and three control projects.



**Photo 36: (ND 3, RP 8) - 30° Safety Edge Fall 2014 North Shoulder Facing East**



**Photo 37: (ND 3, RP 8) - 30° Safety Edge Fall 2014 South Shoulder Facing East**



**Photo 38: (ND 11, RP 41) - 30° Safety Edge 2014 North Shoulder Facing East**



**Photo 39: (ND 11, RP 41) - 30° Safety Edge 2014 South Shoulder Facing East**



**Photo 40: (ND 11, RP 45) - 30° Safety Edge 2014 South Shoulder Facing East**



**Photo 41: (ND 11, RP 45) - 30° Safety Edge 2014 North Shoulder Facing East**



Photo 42 :( ND 13, RP 249) - 30° Safety Edge 2014 North Shoulder Facing West



Photo 43 :( ND 13, RP 249) - 30° Safety Edge 2014 South Shoulder Facing West



**Photo 44: (ND 46, RP 13) - 30° Safety Edge 2014 South Shoulder Facing East**



**Photo 45: (ND 46, RP 13) - 30° Safety Edge 2014 North Shoulder Facing East**



**Photo 46: (ND 11, RP 47) 2014 Control, 4:1 NDDOT Standard South Shoulder Facing East**



**Photo 47: (ND 56, RP 7) 2014 Control 30° Contractor Constructed East Shoulder Facing North**



**Photo 48: (ND 56, RP 7) 2014 Control 30° Contractor Constructed West Shoulder Facing North**



**Photo 49: (ND 30, RP 7) Control 30° Contractor Constructed East Shoulder Facing North**



**Photo 50: (ND 30, RP 7) Control 30° Contractor Constructed West Shoulder Facing North**

### **Summary**

Over the 2011-2012 construction seasons NDDOT constructed five projects totaling 3.795 miles of roadway that implemented the 30° Safety Edge design. The Pavement Ramp Champ device was used on all 5 projects by the same contractor Border States Paving to successfully produce a safe traversable pavement edge. Average angle produced with the Ramp Champ device on all five projects combined was 26.2° with a standard deviation of 4.0°.

The Contractor found the device easy to install and thought it produced a uniform edge while providing additional compaction. The Contractor also noted the device was difficult to adjust in the field compared to other methods. They also noted that a non-uniform grade lines in conjunction with poor compaction at the edges of the base layer; would allow the shoe to cut into the base scraping base material into the HBP. This condition made it difficult to produce a consistent edge.

The Ramp Champ device had signs of wear on the shoe after the five projects and would require maintenance for future use.



**Photo 51: Ramp Champ shoe condition post construction.**

The roller compaction effort affected the final edge depending on the position of breakdown roller; the angle of the edge would be increased or decreased approximately 2.5°.

NDDOT Design Manual, section I-06 also has a 30° shoulder treatment, allowing the contractor to construct the edge as the industries prefers. NDDOT has used this 30° on multiple projects throughout the state. The three control projects were emergency grade raises constructed allowing the contractor to install the edge by their own methods. The contractor chose to use a slough box. Average Angle produced with this method was 20.9° with a standard deviation of 4.5°.

Both methods of producing the 30° safety edge had comparable results during M&R 2<sup>nd</sup> evaluation with neither showing signs of aggregate loss or HBP durability issues. Over the 2014 construction season chip seals had been performed as a preventative maintenance treatment on most of the Safety edge segments this resulted in an increase of pea sized aggregate over the shoulder. This increase in aggregate left over from the chip seal operation negated any minor loss of shoulder aggregate that had occurred. The contractor produced 30° safety edge and Ramp Champ constructed edge had no notable signs of HBP distress or aggregate loss during M&R 2<sup>nd</sup> evaluation.

## **Recommendation**

The objective of this research was to evaluate the construction of the *Safety Edge* using a FHWA provided “safety shoe” device that forms and consolidates the pavement edge. The device functioned properly and constructed the desired safety edge.

The contractor when left the freedom to construction the safety edge as they desired also constructed the specified *Safety Edge*.

Both methods of construction provided a durable *Safety Edge* with no maintenance issues. The recommendation of this research is to allow the contractor to construct the *Safety Edge* with methods that best suit their construction operations.

**Appendix A**

STATE	PROJECT NO.	SECTION NO.	SHEET NO.
ND	SER-2-013(044)249	30	2

Notes

- ① Refer to Section 20 Slope Transition Details for inslope transitions at each end of project limits.

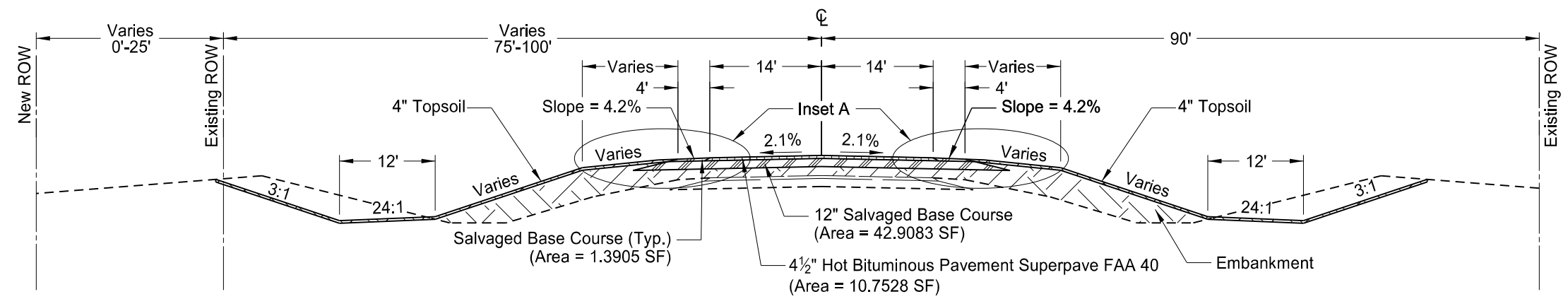

**Proposed Typical Section ①**  
Ditch Section  
(See Section 4 Sheet 1 for Station Ranges)

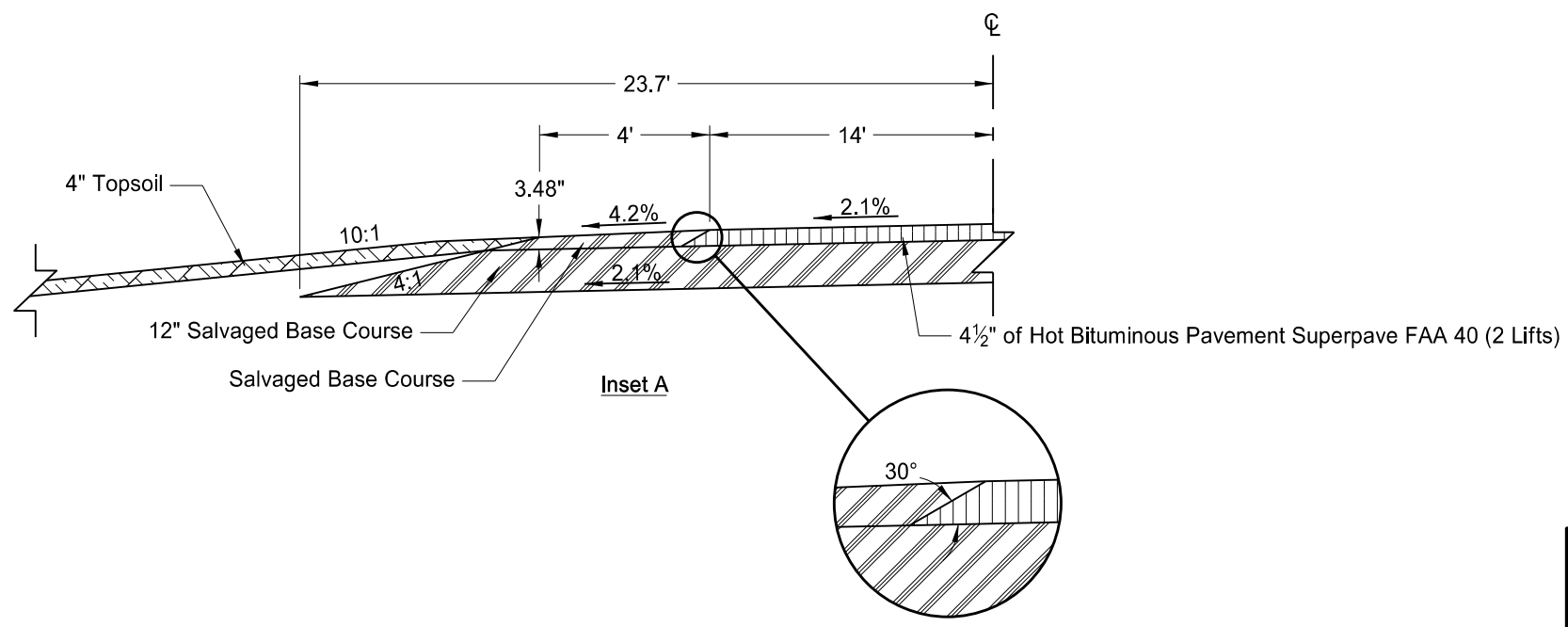

This document was originally issued and sealed by Matthew T. Kinsella Registration Number PE- 5692, on 12/22/11 and the original document is stored at the North Dakota Department of Transportation

Typical Sections  
Proposed Typical Sections  
ND Hwy 13 - Grade Raise

## **Appendix B**

**NORTH DAKOTA DEPARTMENT OF TRANSPORTATION****SPECIAL PROVISION****SAFETY EDGE****MER-2-011(029)041 – PCN 19110****DESCRIPTION**

The Contractor shall be required to construct a Safety Edge on the Hot Bituminous Surfacing. The Department will provide a Pavement Ramp Champ for the Contractor's use in conjunction with this project. The attached Ramp Champ User Manual shall be followed, and the device shall be installed and operated per the manufacturer's recommendations. The device manufacturer's instructions for placement and rolling of Hot Bituminous Surfacing shall be followed.

The Department will not provide any mounting devices. The manufacturer offers a Universal Mounting Bracket. This provides an attachment to shim the mounting plate when the back of the screed is not in a single plane. Attached is the Universal Mounting Bracket user manual. Should shims be needed the contractor may accomplish this by using longer bolts, metal shims or angle iron.

**CONSTRUCTION REQUIREMENTS**

The Contractor shall coordinate the schedule and use of the Ramp Champ with the Valley City District Engineer. The Engineer shall be notified 10 days prior to the start of the paving operation so that representatives from the NDDOT Materials and Research Division can be onsite during the paving operation. If the device is unavailable during the time of the Contractor's paving operation, the Contractor shall construct the 30° HBP Safety Edge as shown in the plans.

Upon completion of the paving operations, the Ramp Champ shall be returned to the NDDOT cleaned and in original condition.

**BASIS OF PAYMENT**

The Safety Edge will not be measured and all costs for the installation, removal, labor, materials, and equipment of the Safety Edge shall be included in the price bid for "Superpave FAA 40".

The Ramp Champ will not be measured and all costs for the installation, use, removal, labor, materials, and equipment of the Ramp Champ shall be included in the price bid for "Superpave FAA 40".

# USER MANUAL

Please review before installation and/or operation.

# Pavement Ramp Champ



## ATTENTION

Read this entire Manual carefully before attempting to install and/or operate. Retain for future reference.



## CAUTION

To avoid injury, use care when lifting, installing, adjusting or operating.

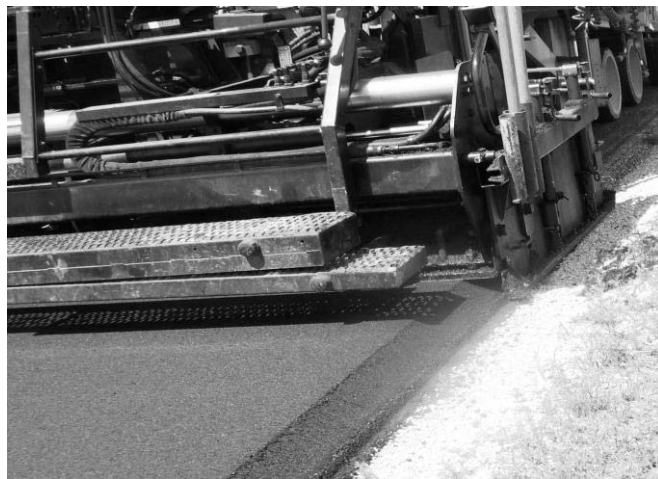

At Advant-Edge Paving Equipment, we are constantly striving to develop products that make our highways safer and last longer. The Ramp Champ is designed to meet both of these objectives. This device has detachable and inter-changeable “shoes” so that the same basic unit can create either a 30° tapered safety edge along the side of the road or a longitudinal center lane joint often referred to as a Michigan Notch Joint to help make a better seam between two lanes. The Ramp Champ has been specifically designed and constructed to meet government guidelines that are being enacted to improve road safety. And, our patent pending reversible design allows the paving contractor to mount the unit on either side of the paver thereby avoiding the need to purchase a left and right side model.

Advant-Edge Paving Equipment, LLC  
33 Old Niskayuna Road  
Loudonville, New York 12211  
Phone: 814.422.3343 (EDGE)  
sales@advantedgepaving.com  
Website: [www.advantedgepaving.com](http://www.advantedgepaving.com)

## TABLE OF CONTENTS

Section 1	Important Safety Precautions.....	page 3
Section 2	Product Overview.....	page 4
Section 3	Description of Key Parts.....	page 7
Section 4	Initial Installation.....	page 10
Section 5	Creating a Safety Edge.....	page 12
Section 6	Creating a Center Lane Joint.....	page 15
Section 7	Reversing the Ramp Champ.....	page 18
Section 8	Important User Information.....	page 20
Section 9	Trouble Shooting.....	page 21
Section 10	Maintenance.....	page 22
Section 11	Warranty.....	page 23

## 1 IMPORTANT SAFETY PRECAUTIONS

- Please read the entire operating manual before installation or operation of this unit.
- Use only according to directions in this user manual or other officially published documents of Advant-Edge Paving Equipment, LLC. This unit is designed to be mounted on the screed or screed extension of paving machines and is intended for asphalt only.
- The Ramp Champ is HEAVY! To avoid injury, use care when lifting, installing or removing. It is recommended that appropriate work gloves be worn when installing, handling and using the Ramp Champ.
- Do not attempt to take apart, repair, modify or otherwise disassemble the Ramp Champ as it will void the warranty and can cause harm to the operator and others if not done correctly. If you are experiencing a problem, call Technical Support at 814-422-3343 (EDGE).
- Always be sure that appropriately trained and qualified personnel are employed to install and operate the product. Also be sure that appropriate tools and procedures are followed at all times.
- During periods when the Ramp Champ is not in use, it is recommended that the holes in the screed (which were created for mounting) be filled (say with a spare bolt or screw) so as to keep them clean.
- **WARNING! DO NOT DRAW THE SCREED EXTENSION TOO CLOSE TO THE MAIN SCREED.** During paving, the Ramp Champ could be exposed to contact with the cross feed auger and auger shaft if the screed extension is drawn in too close to the main screed. Severe damage could occur to both the cross feed auger and the Ramp Champ if they come in contact.
- **WARNING! RAISE THE FORMING BOX TO ITS UPPER MOST POSITION WHEN NOT PAVING AND/OR WHEN MOVING THE PAVER BETWEEN LOCATIONS.** When paving is completed in a given direction and the paver is to be moved to a new location before paving again, the Ramp Champ should be raised to its uppermost position so that its forming edge is at a height above that of the screed.
- **WARNING! IT MAY BE NECESSARY TO UNBOLT THE RAMP CHAMP PRIOR TO TRANSPORTING PAVER.** When transporting the paving machine requires the screed extension to be retracted, it may be necessary on some paving machines to unbolt the Ramp Champ from the screed for transportation. Failure to do so will result in damage to the Ramp Champ and the paving machine.

## 2. PRODUCT OVERVIEW

Technical innovation has led to our new, next generation product: the Ramp Champ. It is capable of producing a variety of road edge profiles that meet the requirements of two different paving challenges:



Paving road with safety edge

1. The tapered 30° safety edge is designed to make our highways safer by reducing the number of "run-off" accidents.
2. The longitudinal center lane joint enables paving crews to create an edge somewhat akin to the "Michigan Notch Wedge Joint" to be used when paving the first of two adjacent highway lanes. This edge will enable the second lane to "bind" with the first lane thereby creating a stronger and longer lasting seam.



Right side oriented Ramp Champ



Left side oriented Ramp Champ

The Ramp Champ is reversible there is no need to purchase a left side and right side model as is the case with our competitors. With Advant-Edge Paving Equipment, it is buy one and it will perform on both sides of the paving machine.

Our units are designed to automatically follow the shoulder elevation. When paving begins, the unit is set to the correct (or lowest) level shoulder height. As the paver moves forward, the Ramp Champ shoe will rotate up (or flatten out the slope of the edge) when it encounters higher shoulder levels (say for driveways). When the shoulder level returns to its normal level, the shoe will automatically rotate back to its original slope and height setting.

As of today, the state and federal specifications being written for safety edges are aimed at creating a 30° slope. In some cases it may be advantageous to create a slightly flatter slope that takes into account a rolling pattern that later tends to increase the slope angle by several degrees. To a large extent creating an edge of 30° after rolling is as much art as science, but the Ramp Champ provides the operator with the flexibility to control the final slope angle. The slope setting of this unit may be changed in the field and set in a range from 5° to 30°.

The Ramp Champ is fitted with shoes that create the desired edge profile. The shoes are detachable by the operator so a Ramp Champ being used as a safety edge maker can be transformed quickly into a longitudinal center lane joint maker.

The safety edge shoe, has two forming surfaces. The leading surface is at an angle to the direction of travel and "funnels" the asphalt to aid compaction. The trailing surface is in line with the direction of travel. It acts as a trowel to smooth the surface and also as the surface which transmits the radial force thereby increasing compaction of the edge. The Safety Edge Shoe is designed to create an edge up to a maximum vertical drop of approximately 5".

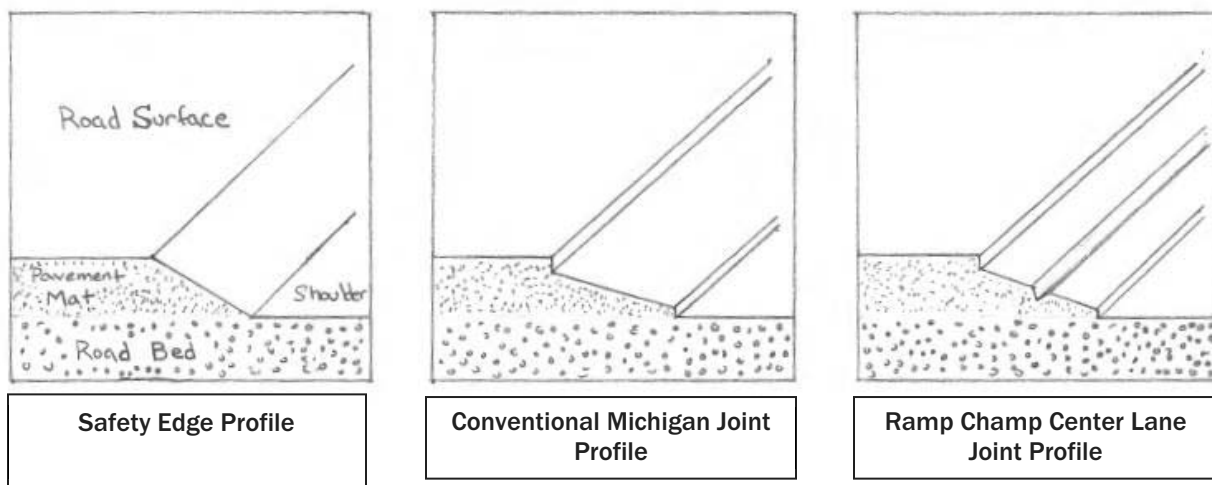

The longitudinal center lane joint shoe is slightly more complex. It creates a profile similar to what is commonly referred to as a "Michigan Notch Wedge Joint." It has an upper

vertical face where the edge meets the pavement mat surface, a tapered face (with an added groove in it to enhance seam binding), and a lower vertical face to provide sufficient material for structural integrity near the road bed. This shoe performs in a similar manner to the safety edge shoe in that they each utilize both compaction surfaces and trowel/radial force surfaces to enhance compaction. The Center Lane Joint Shoe is designed to accommodate pavement surface heights above the adjacent unpaved lane of 1" to 5". A note, although the Ramp Champ is reversible, the Center Lane Joint Shoe is not. The operator must purchase a left and right shoe to create center lane joints on either side of the paving machine.

### **Achieving Desired Results of a 30° Tapered Safety Edge**

The Ramp Champ has been professionally designed and constructed to create a tapered safety edge slope of 5° to 30° (+/-1°) at the road shoulder. The slope can be adjusted in the field and set as desired by the operator. Please note that this slope angle is measured relative to the pavement mat which is normally different from true horizontal. Our company recognizes that no two road paving field conditions are identical and that various factors can create results that differ from the desired 30° target. Thus the value of being able to adjust the slope angle can be of great value in achieving the desired target.

**ACHIEVING THE TARGETED 30° ANGLE MAY BE DEPENDENT UPON A NUMBER OF FACTORS. THE FOLLOWING IMPORTANT OPERATING RULES WILL HELP TO ENSURE THE OPTIMAL ANGLE IS ACHIEVED:**

- Unit is properly mounted and adjusted to the appropriate height (See Sections 4 “Installation” and 5 “Operation”).
- The temperature of the mix and the length of time before the first pass of the roller takes place can alter the slope angle. Softer, hotter mixes will tend to “push the asphalt out” and thereby create a steeper tapered angle. In this event the operator may wish to set the initial formation slope to say 25° as an example so that after rolling the slope will be the targeted 30°.
- Please remember that the 30° edge angle is relative to the slope of the pavement mat and not true horizontal.

### 3. DESCRIPTION OF KEY PARTS

Carefully unpack the shipping container and inspect the contents. You should find a fully assembled Ramp Champ with the Shoe that you ordered. Also in the shipping container is a full set of mounting hardware consisting of: two (2) ½-13 bolts, two (2) lock washers, four (4) regular washers and two (2) ½ -13 nuts.

The Ramp Champ consists of six major components: the Mounting Plate, the Box, the Wedge, the Radial Force Cylinder, a Shoe and a Flap. Our product is built to be used by the road paving construction industry. Nearly all surfaces are made of ¼” steel remaining components such as the springs are made of the stainless steel and/or casted construction grade steel. Our threaded rod is ACME so that it can withstand the stress under paving operations and will withstand dirt and asphalt materials in which it may contact.



The Mounting Plate remains fixed and bolted to the screed thereby providing a foundation for the Ramp Champ to perform its functions. Mounting Slots are used when attaching the Mounting Plate to the screed extension of the paver. ½” bolts, washers, lock washers and nuts are provided to mount the unit. Guide Rails on the Mounting Plate prevent the Box from moving (or swinging) out of position. It is intended to make sure the Box maintains a vertical orientation and thus capable of creating consistent slope angles. The lower part of the Guide Rails are notched out so that the Center Lane Joint Shoe (when used) does not bind on the device. Note: this Mounting Plate has been designed to attach easily to most conventional screeds by simply drilling or tapping two holes in the screed or screed extension.

The Box slides up and down vertically between the guide rails of the Mounting Plate. Its height relative to the Mounting Plate or screed is controlled by turning the Height Adjustment Screw. There is a Cotter Pin on the Height Adjustment Screw. Removal of the Cotter Pin is necessary to detach the Box from the Mounting Plate. The Cover Plate on the

top of the Box protects the inner adjustment elements of the Box from dirt and asphalt. Inside the Box, just under the Cover Plate is a Slope Set Screw which can be used to set the maximum slope angle that the safety edge will create.

The Wedge which is located on the bottom of the Box is designed to rotate (or flatten out) so that 1) different slope angles can be formed and 2) it can follow changes in the elevation of the adjacent road shoulder. On the bottom face of the Wedge are four tapped holes which are used to attach the Shoes.

The Radial Force Cylinder produces downward and inward force (radial) on the Shoe which is one of our products unique features. The orientation of this force creates a more compact and stronger edge/joint. The amount of radial force applied to the Shoe can be controlled by turning the Spring Compression Screw.



Safety Edge Shoe



Longitudinal Center Lane Joint Shoe

The Shoe, depending upon the profile chosen, produces either a tapered safety edge along the side of the road or a longitudinal center lane joint. The Shoe is attached to the bottom of the Wedge with screws and lock washers.

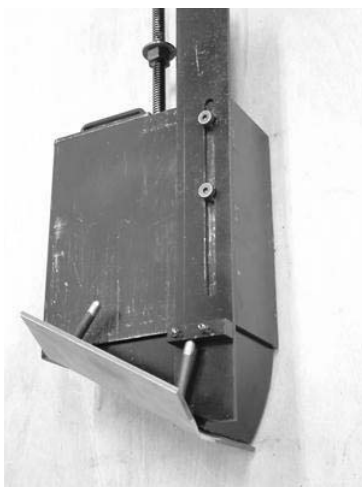

The Flap limits the amount of excess asphalt that may “seep” between the end gate and the Wedge. It is attached to the Box and can slide up and down along an axis defined by the Flap Pins. It is held in place during operation by the Flap Spring. Please Note: The Flap is not required to create a strong quality edge. It only limits the amount of excess asphalt left near the finished edge or joint on the shoulder. The Flap will be most useful when creating safety edges of 20° to 30°. When creating center lane joints (with a vertical drop of 3” or less) or when creating relatively flat safety edge slopes, the amount of excess asphalt seepage will be small either with or without the Flap.

The Flap contains a Flap Bar which makes contact with “push rods” that extend from the Shoe as shown above. These elements of design were included to prevent the Flap from binding when the Shoe pivots up and down.

The Flap also has a series of notches or grooves on its side. These are used to provide the operator with an estimate of the safety edge slope angle being created during the paving operation. Each notch represents a 5 degree change in the tapered slope being created.

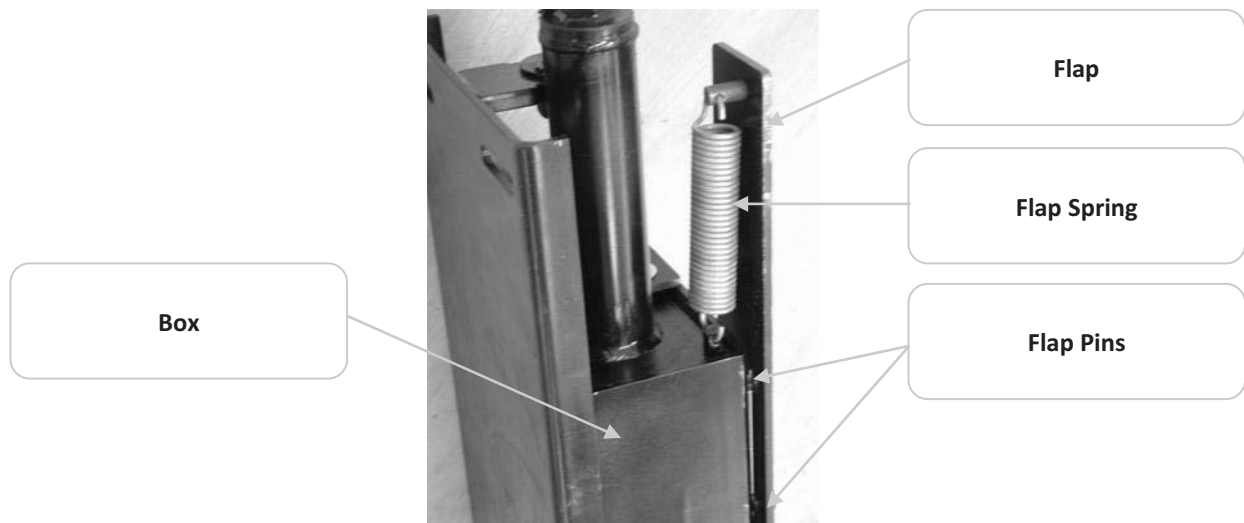

---

## 4. INITIAL INSTALLATION

---

The Ramp Champ is normally shipped with only one end of the Flap Spring attached. As a first step upon unpacking the unit we suggest that you attach the other end. Many times this is easily done by stretching the spring slightly and looping it through the clevis pins at both ends as shown in the picture in the previous section. If this method proves to be difficult, we suggest that you unscrew the Flap Pins, then attach the Flap Spring. Then move the Flap into position and reattach the Flap Pins.

Two holes must be made in the screed extension to mount the Ramp Champ to the Paver. Once these holes are made, the Ramp Champ unit will be easily attachable and detachable from the paving machine as needed. In most cases, the tools required are: a drill, a center tap, a small (metal) tap drill bit,  $\frac{1}{2}$ " (metal) drill bit, and two (2)  $\frac{3}{4}$ " wrenches, one of which should preferably be a socket wrench. In some cases, where it is difficult to access the rear side of the screed, users may find it advantageous to tap holes in the screed extension or weld nuts to the back face of the screed extension that will serve as a secure threaded hole. This method will be explained as well.

**Step 1. Detach Mounting Plate from Box.** Carefully remove the Ramp Champ from the shipping crate and place the assemble unit on the ground or a workbench. Do so carefully as the unit weighs approximately 115lbs. Remove the Cotter Pin at the top of the Height Adjusting Screw and slide the Box off the Mounting Plate.

**Step 2. Position Paver and Screed.** Bring the paving machine to a location where the ground is relatively flat. Note: it need not be true horizontal so long as it is flat. Lower the screed to ground level. Place a 1" shim on the ground in front of the vertical face of the screed extension. With regard to the shim, the important factors are 1) that the bottom edge of the Mounting Plate remains parallel to the edge of the screed trowel surface and 2) the bottom edge of the Mounting Plate is approximately level with the top of the screed compaction edge which tapers up about an inch or so from the trowel level on most screeds.

**Step 3. Position Mounting Plate.** Place the Mounting Plate on the 1" shim with the Mounting Slots at the top of the Mounting Plate. Next, slide the Mounting Plate horizontally along the shim until the outside edge of the Guide Rail is flush against the end gate.

**Important Note:** The Ramp Champ has been designed to easily attach to most paving machines. But, if you find that the entire Mounting Plate surface is not flush against the screed face or if you find that the Mounting Plate is not plumb level or if you find that there is a lower prestrike-off plate that will interfere with the operation of the Ramp Champ when mounted, please STOP the installation process and contact us. Chances are you will need a Universal Mounting Bracket in order to attach the Ramp Champ to your paver.

**Step 4. Mark Holes.** There are two horizontal Mounting Slots on the Mounting Plate. They are symmetrical in size and location. With the unit in position, carefully mark the center line of the two horizontal Mounting Slots then locate your two desired holes on this line and mark with a marker that is easy to see. Each hole will align with the center line of their

respective slot. We have provided slots as opposed to holes so that you may orient the hole you are drilling slightly left or right should there be “obstacles” on the back side of the Screed extension you wish to avoid. It is best staying away from any obstacles as you may be needing to apply a wrench to a nut at the site whenever attaching or removing the Ramp Champ from the paving machine.



**Step 5. Drilling Holes.** It is important that the holes be drilled are very close to where they were marked. Failure to drill in the proper location will result in the Ramp Champ not being perpendicular to the screed forming surface which means that it may not be possible to achieve desired safety edge slope angles. In many cases the paving machine provides the operator easy access to the back side of the vertical screed extension face behind the Mounting Plate. In these cases we suggest simply drilling two holes as described in Step 5(a) below. In cases where the access is limited or difficult, we suggest following the procedure outlined in Step 5 (b).

**Step 5 (a). Easy Access to Back of Screed Extension.** Remove Mounting Plate from shim and set on the side. With a center punch or center tap, mark the center of the two holes to be drilled. Starting with a small pilot drill bit, drill a hole at each location. Next, drill two ½” holes – one for each of the two slots.

**Step 5 (b). Difficult Access to Back of Screed Extension.** Remove Mounting Plate from shim and set on the side. Remove and detach the vertical screed extension face from the paving machine and confirm that there are no “obstacles” immediately behind the marked holes where a nut will be welded on. If there is, move the mark either left or right along the line that will keep it centered in the horizontal Mounting Slots. With a center punch or center tap, mark the center of the two holes to be drilled. Starting with a small pilot drill bit, drill a hole at each location. Next, drill two ½” holes – one for each of the two slots. Two nuts now need to be welded onto the back side of the screed extension. Be sure that each nut is aligned to the hole so that a ½” bolt passing through the hole will be able to

thread into the nut. Reattach the vertical face of the screed extension to the paving machine. Please use only experienced personnel to install these features.

Note: Some operators may wish tap holes directly in the vertical face instead of welding on two nuts. If you choose this method of tapping holes, please first make sure that the vertical face of the screed is sufficiently thick to accept such a tap for a ½” bolt.

**Step 6. Attaching Ramp Champ to Paving Machine.** On the ground or a work bench reattach the Box to the Mounting Plate by sliding the Height Adjusting Screw through the yoke and reinserting the Cotter Pin. Position the unit at the screed extension next to the end gate and insert a ½” bolt and washer into each of the Mounting Slots and through the recently drilled ½” holes. (You may wish to place the unit back on to the 1” shim during the process to make it easier, but it is not necessary). Next slide on a washer and lock washer over the protruding bolt, screw on nut and tighten using appropriate wrenches. The Mounting Plate should be square to the screed and against the end gate. In case where a nut was welded on to the back of the screed extension we recommend sliding a lock washer and regular washer onto the bolt prior to sliding it through the Mounting Slot.

## 5. CREATING A SAFETY EDGE WITH THE RAMP CHAMP

**Setting up the Ramp Champ for Operation.** The Ramp Champ is normally shipped with the Safety Edge Shoe attached to the Wedge and oriented for paving on the right side of the paving machine. This will create a safety edge on the road shoulder when paving in the direction of traffic. If the shoe is not attached, do so by holding the shoe in a vertical position and slipping all four flat head screws through the tapered holes in the shoe. Next, slip a lock washer on each of the protruding screws and then carefully move the shoe into position and thread screws into holes in the Wedge and tighten with an Allen wrench.

If you are interested creating a safety edge with the Ramp Champ on the other side of the paving machine, see section 7 Reversing the Ramp Champ.

If you intend to put down more than one lift or layer of asphalt, we suggest that you use the Ramp Champ only when applying the final lift. Once the paving machine is at the site and ready to begin paving, attach the Ramp Champ to the screed extension as described in Step 6 of Section 4 above. For a 30° slope angle (which is the factory setting of the Maximum Slope Set Screw, proceed as follows:

**Step 1.** Turn the Spring Compression Screw clockwise until the spring begins to exert a force on the Wedge. You will notice that it becomes more difficult to turn the Spring Compression Screw when pressure is being applied. Continue turning the screw so that it travels down approximately ½” to 1”.

**Step 2.** With the screed set at the anticipated paving level and the paver ready to begin paving, lower the Shoe until its bottom edge makes contact with the shoulder. This is done

by turning the Height Adjustment Screw counter clockwise. The entire Box, Wedge and Shoe will move vertically down.

**Corrective Actions.** The Ramp Champ is now set to create a tapered 30° safety edge as measured relative to the pavement surface. Should you find that the edge is less than a 30° slope it is most likely that the shoe needs greater radial compression force to apply against the asphalt or the shoulder elevation has risen relative to the initial height setting. These are easily fixed. If you believe the shoulder elevation has changed, simply turn the Height adjustment screw clockwise. This will raise the shoe vertically up and the radial force will return the shoe's safety edge slope to 30°. If you believe it is not an elevation issue try increasing the radial force by turning the Spring Compression Screw clockwise an additional 1/2" or so.

In some instances you may find that the slope is 30° but there is a "fall-off" at the outer most edge of the safety edge and that the compression of asphalt material does not appear very good at this edge. In this case, the shoe is probably set too high relative to the shoulder and needs to be lowered slightly by turning the Height Adjustment Screw counter clockwise.

At first these adjustments may seem a little tricky but in very short order you should find a setting that is producing a good edge and need very little attention as the paver is laying down asphalt.



Ramp Champ set at 30°



Ramp Champ set at 15°

**Creating Safety Edge Slopes less than 30°.** In some cases, say for example because of rolling patterns that tend to push out the asphalt thereby increasing the slope angle that was initially created by the shoe, the operator may wish to create a slightly flatter angle so that the final result will tie in with a 30° slope.

One way to do this is to take off the Cover Plate and turn the Slope Set Screw clockwise until the desired maximum slope angle is reached. You will see that the wedge and/or shoe will not rotate down as far as the screw is tightened. **For safety reasons, this action should never be done while the paving machine is being operated.** The operator may wish to adjust the Slope Set Screw before the Ramp Champ is mounted on the paving machine because of the limited space involved. Once the maximum slope angle is set, follow steps 1 and 2 above.

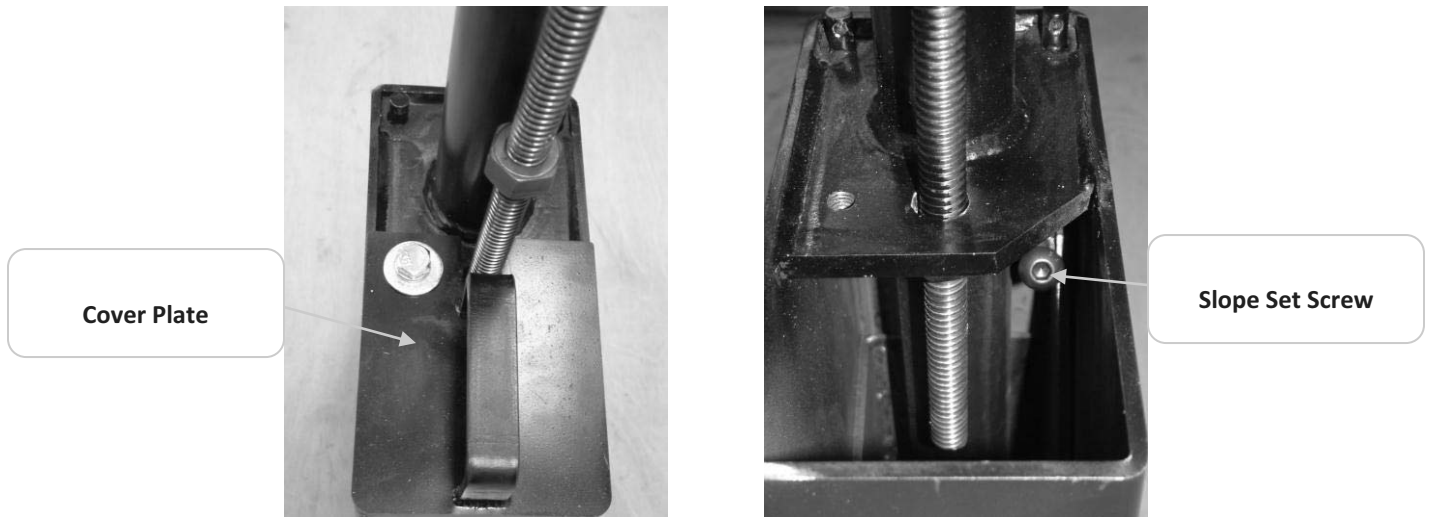

A second way to adjust the slope angle can be easily accomplished in the field while paving. First release the radial pressure on the shoe by turning the Spring Compression Screw counter clockwise. Second, turn the height adjustment screw counter clockwise moving the Box down. This will force the shoe into the shoulder and flatten out the angle. Third, increase the radial pressure on the shoe by turning the Spring Compression Screw clockwise. This final step of increasing pressure will keep the shoe from forming an even flatter slope and help to create a compacted safety edge. Should you experience problems of “holding” the desired angle you want, it may be because the shoulder is not firm enough to support the pressure. In that case you may need to follow the directions of adjusting the Slope Set Screw above.

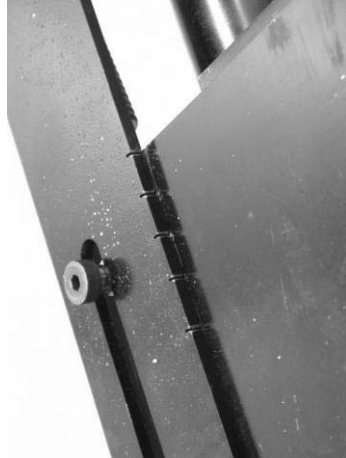

**Measuring the results.** We have calibrated the Flap with a series of notches that will provide a good estimate of the safety edge slope being created without having to constantly take measurements. When the top most edge is even with or just above the top of the Box, the angle is 30°. The second notch is set to correspond with 25°. Each additional notch represents a 5° differential.

## 6. CREATING A CENTER LANE JOINT WITH THE RAMP CHAMP

**Setting up the Ramp Champ for Operation.** If you purchased the Ramp Champ for use with a Center Lane Joint Shoe, it was most likely shipped from the factory with the Shoe attached to the Wedge and oriented for paving on the left side of the paving machine. This will create a joint on the left edge of the road when paving in the direction of traffic. If the shoe is not attached, you must first make sure the Ramp Champ is oriented to be attached to the desired side of the paving machine. The pictures below show a left side and a right side orientation. If your unit is oriented correctly, continue on with this section. If not, go to section 7 Reversing the Ramp Champ. Reverse the orientation and then continue on in this section.



Right side oriented



Left side oriented

Next, attach the Center Lane Joint Shoe by holding the shoe in a vertical position and slipping all four flat head screws through the tapered holes in the shoe. Then slip a lock washer on each of the protruding screws and carefully move the shoe into position and thread screws into holes in the Wedge and tighten with an Allen wrench. For a joint on the left hand side of the paving machine, the assembled Ramp Champ with Center Lane Joint Shoe is pictured below.



**Note that the Center Lane Joint Shoe is not reversible! If you desire to make a center lane joint on the right side of the paving machine you will need to purchase a “right side Center Lane Joint Shoe.” The remainder of the Ramp Champ is fully reversible.**

If you intend to put down more than one lift or layer of asphalt in a timely succession, we suggest that you use the Ramp Champ only when applying the final lift. Once the paving machine is at the site and ready to begin paving, attach the Ramp Champ to the screed extension as described in Step 6 of Section 4 above. Then proceed as follows:

**Step 1.** Turn the Spring Compression Screw counter clockwise raising it until it stops (this is about 6” above the nut it threads in to).

**Step 2.** With the screed set at the anticipated paving level and the paver ready to begin paving, lower the Shoe until its bottom edge makes contact with the adjacent (to be paved later) lane. This is done by turning the Height Adjustment Screw counter clockwise. The entire Box, Wedge and Shoe will move vertically down.

**Step 3.** Continue turning the Height Adjustment Screw counter clockwise this will continue to move the Box down and in the process it will cause the shoe to rotate up or flatten out as it is “pushed” against the adjacent lane surface. Stop turning the Height Adjustment Screw when the Upper Vertical Notch is approximately ½” below the anticipated level of the new pavement surface.



**Step 4.** Next, radial pressure is applied to the shoe so that it will not “float” or rotate up as paving begins. This is done by turning the Spring Compression Screw clockwise until it begins to exert a force on the Wedge. You will notice that it becomes more difficult to turn the Spring Compression Screw at this time. Continue turning the screw so that it travels down an additional  $\frac{1}{2}$ ” to 1”.

**Step 5.** Begin paving. If the joint profile does not look exactly like you want, follow the corrective actions below.

**Corrective Actions.** The Ramp Champ is now set to create a center lane joint that should safely let traffic traverse from the old to new pavement within approximately one to two hours (once the pavement has set). It should also be creating a joint profile as pictured above. Should you find that the Upper Vertical Notch is too deep or too shallow, adjust the joint profile by moving the Box up or down accordingly. This is done by first relieving the pressure on the Shoe by turning the Spring Compression Screw counter clockwise, second, turn the Height Adjustment Screw to raise or lower the unit and third, return the radial pressure to the shoe by turning the Spring Compression Screw clockwise as described in Step 4 above.

Our Center Lane Joint Shoe profile is designed to create a Lower Vertical Notch that is  $\frac{1}{2}$ ” in depth. Should you find that you are creating a joint profile that has a Lower Vertical Notch greater than  $\frac{1}{2}$ ” you may wish to apply more radial pressure by turning the Spring Compression Screw clockwise. This action will also increase the asphalt compression and strength of the joint.

At first these adjustments may seem a little tricky but in very short order you should find a setting that is producing a good joint and needs very little attention as the paver is laying down asphalt.

---

## 7. REVERSING THE RAMP CHAMP

---

At times it will be advantageous to create either the tapered safety edge or the center lane on the opposite side of the paving machine. For safety edges this may occur when the operator is paving in the direction against traffic or when the safety edge is being created on the shoulder of the median of the road. In either case the Ramp Champ is reversible and can be used on either side of the paving machine. In order to switch sides proceed as follows:

**Step 1.** If the unit is currently attached to the paver, raise the Box until it is above the level of the screed trowel surface and unbolt it from the screed. Carefully move it to a safe place.

**Step 2.** Remove the shoe from the Wedge being careful not to lose the lock washers.

**Step 3.** Remove the Flap from the Box by disconnecting the Flap Spring and unscrewing the Flap Pins.

**Step 4.** Remove the Cotter Pin on the Height Adjusting Screw and slide the Box off the Mounting Plate.

**Step 5.** Rotate the Box 180° (i.e. flip it over) and slide it back onto the Mounting Plate and attach the cotter pin.

**Step 6.** Attach the Safety Shoe by rotating it 180°. The shoe is attached by holding it in a vertical position and slipping all four flat head screws through the tapered holes in the shoe. Next, slip a lock washer on each of the protruding screws and then carefully move the shoe into position and thread screws into holes in the Wedge and tighten with an Allen wrench. Note: the same safety Shoe can be used on either side of the paving machine by simply rotating it 180°. This is not the case with the Center Lane Joint Shoe. These shoes have a left and right orientation and the appropriate shoe must be purchased and used on each side.

**Step 7.** Reversing the Flap by first reversing the position of the Flap Bar. This is done by unscrewing the two screws that hold the Flap Bar in place, flipping the Flap over, and then re-attaching the Flap Bar on the opposite side of the Flap.

**Step 8.** Attach the Flap by securing it in place using the two Flap Pins that had been removed. You will see that there are two holes for the Flap Pins facing up (away from the Mounting Plate) on the side of the Box that will now be closest to the end gate. Next, attach the Flap Spring. If this proves to be difficult, we suggest that you unscrew the Flap Pins, then attach the Flap Spring. Then move the Flap into position and reattach the Flap Pins.

**Step 9.** The Ramp Champ is now ready to attach to the other side of the paving machine. If mounting holes are already in place, simply bolt on. If not, follow the mounting and installation instructions in section 3.

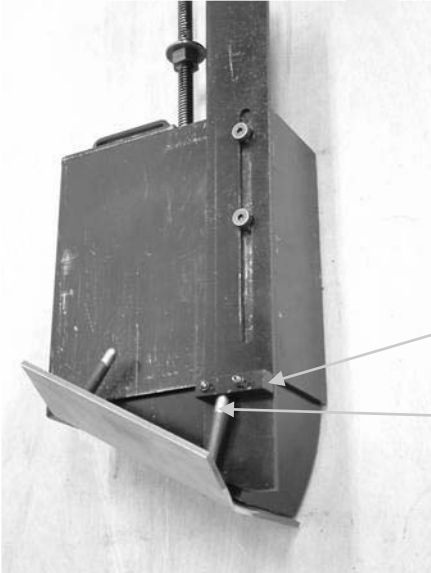

**Flap Bar**

**Push Rod**

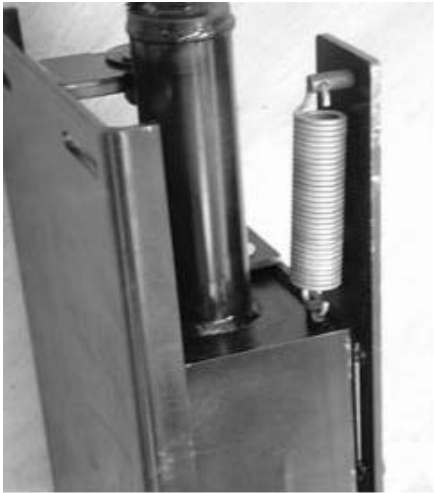

## 8. IMPORTANT USER INFORMATION

**Lane Width.** The width of the tapered safety edge is not to be included in the total measurement of the desired lane width. The end gate needs to be extended beyond the desired lane width by an amount equal to the width of the tapered edge. Fully extended the Ramp Champ creates a 30° tapered edge that is approximately 8” wide.

**Rolling Patterns.** It is recommended that the first rolling pass on the freshly laid road be made with the roller drum 8” to 12” away from the tapered edge of the lane. This will help to ensure that the tapered edge will not “roll up” or push out due to outward pressure from the roller. The roller should be driven straight up to the back of the paver and reversed without turning the roller so as to keep constant distance from the edge.

**Rolling the edge.** Attempting to roll the tapered edge is likely result in damage or distortion of the edge. It is not necessary to roll the edge as the Ramp Champ’s patent pending radial compaction pressure creates a very strong and viable edge.

**WARNING! DO NOT DRAW THE SCREED EXTENSION TOO CLOSE TO THE MAIN SCREED.** During paving, the Ramp Champ could be exposed to contact with the cross feed auger and auger shaft in some models of paving machines when the screed extension is drawn in too close to the main screed. Please check if this is the case with your machine. Severe damage can occur to both the cross feed auger and the Ramp Champ if they come in contact.

**WARNING! RAISE THE BOX TO ITS UPPER MOST POSITION BEFORE MOVING OR TRANSPORTING THE PAVER.** When paving is completed in a given direction and the paver is to be moved to a new position, the Ramp Champ should be raised to its uppermost position.

**Keeping the End Gate in Proper Position.** In order for the Ramp Champ to work properly, the end gate should be riding directly on the surface of the shoulder being paved at all times. Most end gates have a tension rod or compression spring mechanism which can be adjusted to keep enough downward pressure on the end gate so that it does not lift up during paving. If the end gate lifts off the shoulder for any reason, asphalt may flow out the side of the paver and not provide enough asphalt to the Ramp Champ to achieve proper consolidation.

## 9. TROUBLE SHOOTING

### **No visible angle has been produced or the angle doesn't reach the road shoulder**

Check if the Shoe has been lowered to the appropriate position (See Section 5. CREATING A SAFETY EDGE WITH THE RAMP CHAMP) If not, turn the Height Adjusting Screw counterclockwise until the Shoe reaches the shoulder of the road while the screed is resting on the new pavement.

### **The angle of the paved surface is tearing**

This may be due to the temperature of the mix; mixes that are too cool may cause the material to tear. The composition of the mix may be at fault as well; mixes that are too dry may cause tears in the surface.

### **The angle appears to be too steep**

The Ramp Champ is designed to create at most a 30° slope. First make sure the angle is being measured relative to the road's surface, not true horizontal. Be sure that the correct rolling patterns have been used (See Section 5.2, "Rolling Patterns"). Check the unit and make sure it is flush against the end gate and square to the screed forming surface. Check the Box and be sure it is nestled between the Guide Rails.

### **The tapered safety edge seems to lack structural integrity and is breaking up**

The underlying shoulder and ground beneath the safety edge being formed must be firm and compacted prior to paving. Failing to do this may result in an inability to form a quality edge either during the paving process, and/or after the road is completed as the surrounding shoulder "settles."

### **The device is cutting through the shoulder instead of moving with the terrain**

If the shoulder is not too soft, this may occur when the Spring Compression Screw is too tight and creating too much radial force or when the Shoe is too low and the Height Adjustment Screw need to be turned clockwise to raise the Shoe.

### **The Height Adjusting Screw will no longer turn counterclockwise**

Our unit is designed with both upper and lower limit stops. In its highest position, the Shoe will be even with or just above the lower edge of the Mounting Plate. The lower stop allows the top edge of the Shoe to reach a position approximately 2" lower than the bottom edge of the Mounting Plate. The unit is designed in this way in order to maintain its operating performance.

### **The Screws are stuck or seems too difficult to turn**

First clean off all threads using your normal asphalt cleaning process. If the difficulty still exists, the screw may have been damaged or bent and may need to be replaced. We believe this is not likely to happen although, should it occur we will be able to supply you with replacement parts. Replacing the Height Adjusting Screw is not difficult. The Spring Compression Screw will need to be repaired at the factory.

**Asphalt is accumulating on the shoulder next to the edge or joint being created.**

This can be due to the end gate not being sufficiently low enough or the Flap not being adjusted correctly. First check the end gate settings. If this is okay, the Flap may need to be lowered. This can be done by grinding down or cutting off a portion of the “push rod” that extends from the Shoe and makes contact with the Flap Bar.

For assistance during preparation, installation and use of the Ramp Champ

- call Technical Support at 1-814-422-3343 (EDGE) or
- e-mail us at [sales@advantedgepaving.com](mailto:sales@advantedgepaving.com)

## 10. MAINTENANCE

We suggest that you care for your Ramp Champ in a manner similar to all other paving machine accessories. The unit should be cleaned daily after use with your usual asphalt cleaning solutions. We recommend those that are environmentally safe. Additionally, the Ramp Champ should be stored in a dry location. Constant exposure to rain and weather conditions may affect its performance.

## 11. WARRANTY

**EXPRESS LIMITED WARRANTY.** Advant-Edge Paving Equipment, LLC warrants to the original purchaser only (Buyer) and subject to the limitations, terms and conditions and exclusions set forth herein: the Ramp Champ unit(s) are warranted only against failure due to defective material or workmanship for the period of one (1) year from the date of delivery.

**THIS WARRANTY IS IN LIEU OF ALL OTHER WARRANTIES, WHETHER EXPRESS, IMPLIED OR STATUTORY, AND ALL OTHER LIABILITIES (CONTRACT, TORT OR OTHERWISE, INCLUDING NEGLIGENCE) AND ADVANT-EDGE PAVING EQUIPMENT, LLC MAKES NO WARRANTY OF MERCHANTABILITY OR OF FITNESS FOR ANY PARTICULAR PURPOSE. THIS WARRANTY WILL AUTOMATICALLY TERMINATE AND BECOME VOID UPON THE SALE, TRANSFER OR CONVEYANCE OF THE RAMP CHAMP UNIT(S) OR MACHINE, MACHINE ATTACHMENT OR PROPERTY ON WHICH THE RAMP CHAMP UNIT(S) ARE INSTALLED AND OPERATED.**

**ADVANT-EDGE PAVING EQUIPMENT, LLC DOES NOT MAKE ANY WARRANTY OR ASSUME ANY OBLIGATION WITH RESPECT TO THE VALIDITY OF ANY PATENTS, DESIGNS, COPYRIGHTS OR TRADEMARKS WHICH MAY COVER SUCH RAMP CHAMP UNIT. THE CONDITIONING OF LIABILITY, RIGHTS, OBLIGATIONS AND REMEDIES OF THE BUYER RELATING TO CLAIMS ARISING FROM A DEFECTIVE RAMP CHAMP UNIT(S) SHALL BE GOVERNED EXCLUSIVELY BY THE TERMS OF THIS SECTION 11 HEREOF.**

This EXPRESSED LIMITED WARRANTY does NOT apply where there has failure of the Ramp Champ unit(s) due to improper use; breakage not due to defect, including, but not limited to, natural forces and/or acts of God; failure on account of faulty or improper installation or handling; where repairs or modifications have been made or attempted by others; or failure on account of installation in or on a product of faulty design or construction. As an example, this EXPRESS LIMITED WARRANTY will NOT apply if an object of any kind is attached to Ramp Champ unit without the prior written consent of Advant-Edge Paving Equipment, LLC. Sales representatives of Advant-Edge Paving Equipment, LLC are not authorized to make warranties about the Ramp Champ unit. Advant-Edge Paving Equipment, LLC sales representatives' ORAL STATEMENTS DO NOT CONSTITUTE WARRANTIES, shall not be relied upon by Buyer, and are not part of the contract for sale.

If Buyer believes it has purchased a defective Ramp Champ unit(s) as described above, Buyer must notify Advant-Edge Paving Equipment, LLC immediately in writing why Buyer believes the Ramp Champ unit(s) are defective. Advant-Edge Paving Equipment, LLC may then request the Buyer to return the allegedly defective Ramp Champ unit(s) to Advant-Edge Paving Equipment, LLC; have an Advant-Edge Paving Equipment, LLC representative inspect the unit(s) at the job site, as installed, or at Advant-Edge Paving Equipment, LLC's address; and/or rely upon the information Buyer has provided to determine whether the unit(s) are defective as described above. If any unit(s) are proven to be defective as

described above, then Advant-Edge Paving Equipment, LLC will, at Advant-Edge Paving Equipment, LLC's sole discretion, either repair or replace the defective unit(s) or issue to Buyer a credit equal to the price of the defective unit(s) charged by Advant-Edge Paving Equipment, LLC to Buyer. Said repair or replacement of defective unit(s) or issuance of credit shall constitute fulfillment of all liabilities of Advant-Edge Paving Equipment, LLC to Buyer with respect to, or arising out of, the unit(s), whether based on contract, negligence, strict tort or otherwise. Advant-Edge Paving Equipment, LLC reserves the right to change design, color, models and to discontinue the manufacture of any unit(s).

**LIMITATION OF LIABILITY.** Advant-Edge Paving Equipment, LLC shall not under any circumstances be liable for incidental damages or for special or consequential damages. The remedies of Buyer set forth herein are exclusive, and the liability of Advant-Edge Paving Equipment, LLC with respect to any contract or anything done in connection therewith such as the performance or breach thereof, or from the manufacture, sale, delivery, resale, installation or use of any Ramp Champ unit(s) covered by or furnished to Buyer, whether arising out of contract, negligence, strict tort, or under any warranty or otherwise, shall not, except as expressly provided herein, exceed the price of the unit(s) upon which such liability is based. This limitation of liability applies to original and replacement unit(s).

**CONTROLLING LAW.** The sale, delivery and use of Ramp Champ unit(s) shall be governed by, and this warranty shall be construed and enforced in accordance with, the laws of State of New York.

\*\*\*\*\*

Advant-Edge Paving Equipment, LLC  
33 Old Niskayuna Road  
Loudonville, New York 12211  
Phone: 814.422.3343 (EDGE)  
sales@advantedgepaving.com  
Website: [www.advantedgepaving.com](http://www.advantedgepaving.com)

\*\*\*\*\*

# USER MANUAL

Please review before installation and/or operation.

# Universal Mounting Bracket



## ATTENTION

Read this entire Manual carefully before attempting to install and/or operate. Retain for future reference.



## CAUTION

To avoid injury, use care when lifting, installing or adjusting.



Each paving machine manufacturer has their own unique screed and screed extension design. Our road safety edge products and center lane jointing products are designed to attach to most standard paving machines by simply drilling two holes in the screed (or screed extension).

For those paving machines which do not allow our edging and jointing products to attach easily, we have developed a Universal Mounting Bracket. This bracket can be attached to any paving machine and our products can then be attached to it.

This product represents yet another creative effort to make the job of constructing safe and long lasting roads as easy as possible for the operator.

Advant-Edge Paving Equipment, LLC

33 Old Niskayuna Road

Loudonville, New York 12211

Phone: 814.422.3343 (EDGE)

sales@advantedgepaving.com

Website: [www.advantedgepaving.com](http://www.advantedgepaving.com)

Patents Pending

©2010 Advant-Edge Paving Equipment, LLC

## TABLE OF CONTENTS

Section 1.	Important Safety Precautions.....	page 3
Section 2.	Product Background and Overview.....	page 3
Section 3.	Description of Key Parts.....	page 5
Section 4.	Installation and Use.....	page 7
Section 5.	Maintenance.....	page 9
Section 6.	Warranty.....	page 10

## 1. IMPORTANT SAFETY PRECAUTIONS

- Please read the entire operating manual before installation or operation of this unit.
- Use only according to directions in this user manual or other officially published documents of Advant-Edge Paving Equipment, LLC. This unit is designed to be mounted on the screed or screed extension of paving machines and is intended for asphalt only.
- The Universal Mounting Bracket is HEAVY! To avoid injury, use care when lifting, installing or removing. Wear work gloves as appropriate.
- Do not attempt to take apart, repair, modify or otherwise disassemble the Universal Mounting Bracket as it will void the warranty and can cause harm to the operator and others if not done correctly. If you are experiencing a problem, call Technical Support at (814)422-3343.
- During periods when the Universal Mounting Bracket is not in use, it is recommended that the holes in the screed (which were created for mounting) be filled so as to keep them clean.
- **WARNING! DO NOT DRAW THE SCREED EXTENSION TOO CLOSE TO THE MAIN SCREED.** During paving, the Universal Mounting Bracket could be exposed to contact with the cross feed auger and auger shaft if the screed extension is drawn in too close to the main screed. Severe damage could occur to both the cross feed auger and the Universal Mounting Bracket if they come in contact.

**IF YOU HAVE ANY QUESTIONS, PLEASE REFER TO SECTION 6. "TROUBLE SHOOTING" AND/OR CALL TECHNICAL SUPPORT AT (814) 422-3343 (EDGE).**

## 2. PRODUCT BACKGROUND AND OVERVIEW

Each paving machine manufacturer has their own unique screed and screed extension design. Our road safety edging products and center lane jointing products are designed to attach to most standard paving machines by simply drilling two holes in the screed or screed extension ("Screed"). There should never be a need to make major alterations to your equipment such as cutting away strike-off or kick out plates that are in the way.

We have noticed that on some models of the Blaw-Knox, Volvo and Carlson paving machines our edging and jointing products will not easily attach unless our Universal Mounting Bracket is employed. The reasons for the difficulty in attachment arise from Screed designs that have one or more of the following elements:

1. A lower strike-off plate (or kick-out plate) that prevents our product from being mounted plumb and/or prevents our products from moving up and down or rotating as designed.
2. A curved or arched Screed face.
3. An uneven Screed face with bolts and or other items that prevent a device from being attached plumb
4. An angled Screed face that prevents our units from being attached in a plumb position.

Our edging and jointing products are designed to attach to Screeds that have a minimum of 19" of flat, vertical Screed face. As an operator, if you find when attaching our edging or jointing products that they do not sit plumb and flush against the Screed, or if you find that there is a lower or upper kick-out plate on the Screed that interferes with the operation of our product, you will require a Universal Mounting Bracket in order to avoid making permanent alterations to your paving machine.

We make two sizes of the Universal Mounting Bracket. One for our Ramp Champ (11 1/2" wide) and the other for our Advant-Edger (10" wide).

### 3. DESCRIPTION OF KEY PARTS

The Universal Mounting Bracket consists of four major components: the Rear Plate, the Forward Plate, the Leveling Feet, and the Flap. The purpose of the Universal Mounting Bracket is to provide a flat and plumb surface on which our edging and jointing products can attach. Simply put, our Universal Mounting Bracket attaches to the Screed face via two bolts and our edging and/or jointing products attach to the Universal Mounting Bracket via two more bolts. The Universal Mounting Bracket essentially holds the edging or jointing devices plumb and away from any Screed obstacles that might impair its performance. Additionally, the Universal Mounting Bracket has a Flap that prevents excess asphalt from flowing between the edging device and the Screed.

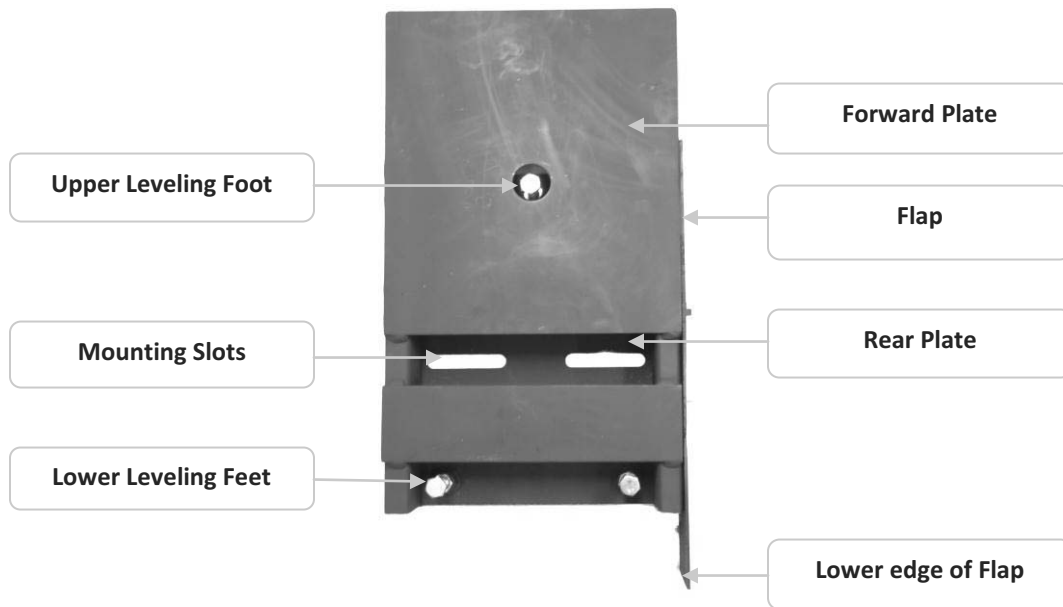

Mounting Slots are used for attaching the Universal Mounting Bracket to the Screed of the paver.  $\frac{1}{2}$ " bolts, washers, lock washers and nuts are provided to mount the unit.

## 4. INSTALLATION and USE

### Unpacking the Universal Mounting Bracket

Carefully unpack the shipping container and inspect the contents. You should find an assembled Universal Mounting Bracket configured in an orientation to be attached to the right hand side of the paver (i.e. for creating a shoulder edge when traveling in the direction of traffic). See section 5 to configure the unit for paving the left hand side of the road.

The assembled unit contains three leveling feet (1/2" bolts with lock nuts) and two bolts with washers and lock washers that hold the Flap in place. Also in the container is a full set of mounting hardware consisting of: two (2) 1/2-13 bolts, two (2) lock washers, four (4) regular washers and two (2) 1/2 -13 nuts.

Two holes must be made in the screed to mount the Universal Mounting Bracket. In most cases, the tools required are: a drill, a pilot drill bit, a 1/2" drill bit, and two (2) 3/4" wrenches, one of which should preferably be a socket wrench. In some cases, where it is difficult to access the rear side of the screed, users may find it advantageous to drill holes in the screed and then weld two nuts onto the back side of the screed behind the holes. This method will be explained as well.

There are two Mounting Slots on the Universal Mounting Bracket. They are symmetrical in size and location and are used to attach the bracket to the Screed. They are not used for attaching the bracket to the edging or jointing device.

### For installation on Screeds with lower strike-off plates or kick out plates.

- **Step 1:** With the paving machine on level ground, lower the screed so that it is resting on the ground.
- **Step 2:** Orient the Universal Mounting Bracket as in shown in the pictures above. The side with the Mounting Slots should be against the Screed and the end with the two leveling screws should be down. The Flap is shipped in an orientation assuming you are attaching the bracket to the right hand side of the paving machine, thus you should find that the flap is on the side away from the end gate. If the Flap is on the side that is abutting the end gate, please unbolt the Flap and re-bolt it to the other side.
- **Step 3:** Assuming the screed face is plumb and flat, make sure the Leveling Feet screws are not extending through the rear of the bracket.
- **Step 4:** Position the Universal Mounting Bracket vertically against the screed. The bottom edge of the bracket should be just above the lower strike-off plate of the Screed. The side of the bracket should lightly abut the end gate. Leaving a small gap of 1/16" or 1/8" to prevent binding is fine.

- **Step 5: Mark the center location of the Mounting Slots on the Screed face.**
- **Step 6: Drill two 1/2" holes – one for each of the two slots. In cases where access to the rear of the screed is difficult users may wish to tap two holes in the screed that will accept the 1/2-13 UNC bolt. If this alternate approach is taken please make sure that the screed is sufficiently thick to accept a tap. If it is not, we recommend that a nut be welded to the back of the screed in order to achieve a secure attachment. In the event that a cutting torch and welding is desired, only an experienced welder shall prepare the paver for mounting the bracket.**
- **Step 7: Position the Universal Mounting Bracket over the recently drilled holes and attach by inserting a 1/2-13 bolt and washer into each of the Mounting Slots and through the 1/2" holes. Next slide on a washer and lock washer over the protruding bolt, screw on nut and tighten using appropriate wrenches. The bracket should be square to the screed and plumb level.**

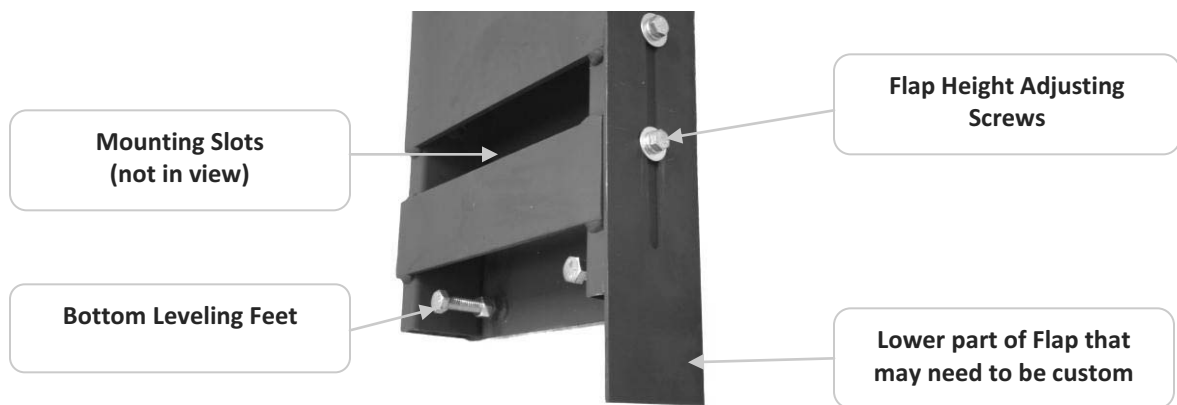

- **Step 8: Adjust and fit the Flap to the profile of your paver's lower strike-off plate. Loosen the Flap bolts and lower the Flap until it is resting on the strike-off plate. Next mark the corner of the Flap that needs to be cut off so that it will fit snugly against the strike-off plate when lowered. Cut off the corner. Note: this is an important step to do so as to prevent excess asphalt from flowing between the Screed and the edging /jointing device and leaving a pile of unwanted asphalt on top of the newly formed edge or joint.**
- **Step 9: Attach the edging or jointing device to the Universal Mounting Bracket according to the user manual(s) for these devices. Note the operator will now need to mark and drill two holes in the bracket when first installing these devices.**

**For installation on Screeds which do not have plumb level faces or have uneven faces which prevent the edging device from being attached in a plumb manner.**

- **Step 1:** With the paving machine on level ground, lower the screed so that it is resting on the ground.
- **Step 2:** Orient the Universal Mounting Bracket as in shown in the pictures above. The side with the Mounting Slots should be against the Screed and the end with the two leveling screws should be down. The Flap is shipped in an orientation assuming you are attaching the bracket to the right hand side of the paving machine, thus you should find that the flap is on the side away from the end gate. If the Flap is on the side that is abutting the end gate, please unbolt the Flap and re-bolt it to the other side.
- **Step 3:** Set the Universal Mounting Bracket on a shim that is 1" to 2" high (2" by 4" works well) and hold the bracket vertically against the face of the Screed.
- **Step 4:** Next, slide the bracket toward the end gate. The side of the bracket should lightly abut the end gate. Leaving a small gap of 1/16" or 1/8" to prevent binding is fine.
- **Step 5:** Adjust the bracket so that it is plumb level using the leveling feet. Be sure to tighten the inside nut so that the setting will not vibrate loose. Should you find that one of the feet is directly on a bolt or other part of the screed which prohibits making a leveling adjustment possible, change the shim height in step 3.
- **Step 6:** Mark the center location of the Mounting Slots on the Screed face.
- **Step 7:** Drill two 1/2" holes – one for each of the two slots. In cases where access to the rear of the screed is difficult users may wish to tap two holes in the screed that will accept the 1/2-13 UNC bolt. If this alternate approach is taken please make sure that the screed is sufficiently thick to accept a tap. If it is not, we recommend that a nut be welded to the back of the screed in order to achieve a secure attachment. In the event that a cutting torch and welding is desired, only an experienced welder shall prepare the paver for mounting the bracket.
- **Step 8:** Position the Universal Mounting Bracket over the recently drilled holes and attach by inserting a 1/2-13 bolt and washer into each of the Mounting Slots and through the 1/2" holes. Next slide on a washer and lock washer over the protruding bolt, screw on nut and tighten using appropriate wrenches. The bracket should be square to the screed and plumb level.
- **Step 9:** Adjust and fit the Flap to the profile of your paver's lower profile if necessary. If there is a gap between the bracket and the Screed face, this can be an important step to do so as to prevent excess asphalt from flowing between the Screed and the edging /jointing device and leaving a pile of unwanted asphalt on

top of the newly formed edge or joint. To “fill” the gap, loosen the Flap bolts and lower the Flap until it is approximately 1” above ground level. Then, tighten Flap bolts.

- **Step 10:** Attach the edging or jointing device to the Universal Mounting Bracket according to the user manual(s) for these devices. Note the operator will now need to mark and drill two holes in the bracket when first installing these devices.

For assistance during preparation, installation and use of the Advant-Edger,

- call Technical Support at 1-814-422-3343 (EDGE) or
- e-mail us at [sales@advantedgepaving.com](mailto:sales@advantedgepaving.com)

## 5. MAINTENANCE

In the past, diesel fuel has been used to clean paving equipment and tools of residue and materials left over. This method of maintenance and cleaning can be dangerous and harsh on the environment. Recently, soy based cleaning agents are being widely accepted to be just as effective on cleaning paving equipment but without the harmful effects on the environment. Similar cleaning techniques used on your other paving equipment may be applied to cleaning our products. We suggest that the Universal Mounting Bracket be cleaned after use on a daily basis.

## 6. WARRANTY

**EXPRESS LIMITED WARRANTY.** Advant-Edge Paving Equipment, LLC warrants to the original purchaser only (Buyer) and subject to the limitations, terms and conditions and exclusions set forth herein: the Universal Mounting Bracket unit(s) are warranted only against failure due to defective material or workmanship for the period of one (1) year from the date of delivery.

**THIS WARRANTY IS IN LIEU OF ALL OTHER WARRANTIES, WHETHER EXPRESS, IMPLIED OR STATUTORY, AND ALL OTHER LIABILITIES (CONTRACT, TORT OR OTHERWISE, INCLUDING NEGLIGENCE) AND ADVANT-EDGE PAVING EQUIPMENT, LLC MAKES NO WARRANTY OF MERCHANTABILITY OR OF FITNESS FOR ANY PARTICULAR PURPOSE. THIS WARRANTY WILL AUTOMATICALLY TERMINATE AND BECOME VOID UPON THE SALE, TRANSFER OR CONVEYANCE OF THE UNIVERSAL MOUNTING BRACKET(S) OR MACHINE, MACHINE ATTACHMENT OR PROPERTY ON WHICH THE UNIVERSAL MOUNTING BRACKET UNIT(S) ARE INSTALLED AND OPERATED.**

**ADVANT-EDGE PAVING EQUIPMENT, LLC DOES NOT MAKE ANY WARRANTY OR ASSUME ANY OBLIGATION WITH RESPECT TO THE VALIDITY OF ANY PATENTS, DESIGNS, COPYRIGHTS OR TRADEMARKS WHICH MAY COVER SUCH UNIVERSAL MOUNTING BRACKET UNIT. THE CONDITIONING OF LIABILITY, RIGHTS, OBLIGATIONS AND REMEDIES OF THE BUYER RELATING TO CLAIMS ARISING FROM A DEFECTIVE UNIVERSAL MOUNTING BRACKET UNIT(S) SHALL BE GOVERNED EXCLUSIVELY BY THE TERMS OF THIS SECTION 6 HEREOF.**

**This EXPRESSED LIMITED WARRANTY does NOT apply where there has failure of the Universal Mounting Bracket unit(s) due to improper use; breakage not due to defect, including, but not limited to, natural forces and/or acts of God; failure on account of faulty or improper installation or handling; where repairs or modifications have been made or attempted by others; or failure on account of installation in or on a product of faulty design or construction. As an example, this EXPRESS LIMITED WARRANTY will NOT apply if an object of any kind is attached to Universal Mounting Bracket unit without the prior written consent of Advant-Edge Paving Equipment, LLC. Sales representatives of Advant-Edge Paving Equipment, LLC are not authorized to make warranties about the Universal Mounting Bracket unit. Advant-Edge Paving Equipment, LLC sales representatives' ORAL STATEMENTS DO NOT CONSTITUTE WARRANTIES, shall not be relied upon by Buyer, and are not part of the contract for sale.**

**If Buyer believes it has purchased a defective Universal Mounting Bracket unit(s) as described above, Buyer must notify Advant-Edge Paving Equipment, LLC immediately in writing why Buyer believes the Universal Mounting Bracket unit(s) are defective. Advant-Edge Paving Equipment, LLC may then request the Buyer to return the allegedly defective Universal Mounting Bracket unit(s) to Advant-Edge Paving Equipment, LLC; have an Advant-Edge Paving Equipment, LLC representative inspect the unit(s) at the job site, as installed,**

or at Advant-Edge Paving Equipment, LLC's address; and/or rely upon the information Buyer has provided to determine whether the unit(s) are defective as described above. If any unit(s) are proven to be defective as described above, then Advant-Edge Paving Equipment, LLC will, at Advant-Edge Paving Equipment, LLC 's sole discretion, either repair or replace the defective unit(s) or issue to Buyer a credit equal to the price of the defective unit(s) charged by Advant-Edge Paving Equipment, LLC to Buyer. Said repair or replacement of defective unit(s) or issuance of credit shall constitute fulfillment of all liabilities of Advant-Edge Paving Equipment, LLC to Buyer with respect to, or arising out of, the unit(s), whether based on contract, negligence, and strict tort or otherwise. Advant-Edge Paving Equipment, LLC reserves the right to change design, color, and models and to discontinue the manufacture of any unit(s).

**LIMITATION OF LIABILITY.** Advant-Edge Paving Equipment, LLC shall not under any circumstances be liable for incidental damages or for special or consequential damages. The remedies of Buyer set forth herein are exclusive, and the liability of Advant-Edge Paving Equipment, LLC with respect to any contract or anything done in connection therewith such as the performance or breach thereof, or from the manufacture, sale, delivery, resale, installation or use of any Universal Mounting Bracket unit(s) covered by or furnished to Buyer, whether arising out of contract, negligence, strict tort, or under any warranty or otherwise, shall not, except as expressly provided herein, exceed the price of the unit(s) upon which such liability is based. This limitation of liability applies to original and replacement unit(s).

**CONTROLLING LAW.** The sale, delivery and use of Universal Mounting Bracket unit(s) shall be governed by, and this warranty shall be construed and enforced in accordance with, the laws of State of New York.

\*\*\*\*\*

**Advant-Edge Paving Equipment, LLC**  
**33 Old Niskayuna Road**  
**Loudonville, New York 12211**  
**Phone: 814.422.3343 (EDGE)**  
**sales@advantedgepaving.com**  
**Website: [www.advantedgepaving.com](http://www.advantedgepaving.com)**

\*\*\*\*\*