

EROSION AND SILTATION CONTROLS  
MEDIAN OR DITCH INLET PROTECTION

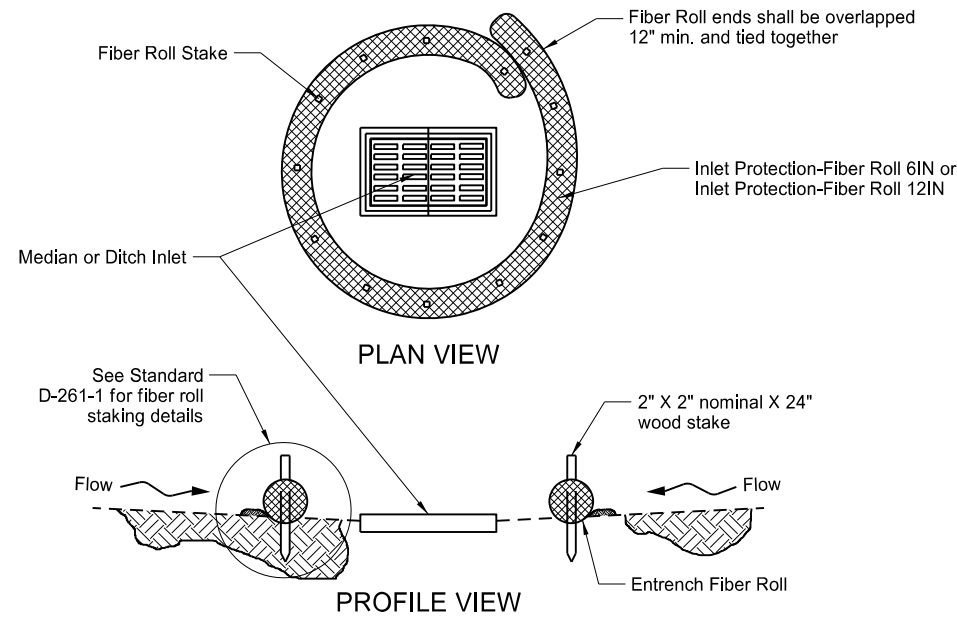

FIBER ROLL PROTECTION (MEDIAN OR DITCH INLET)

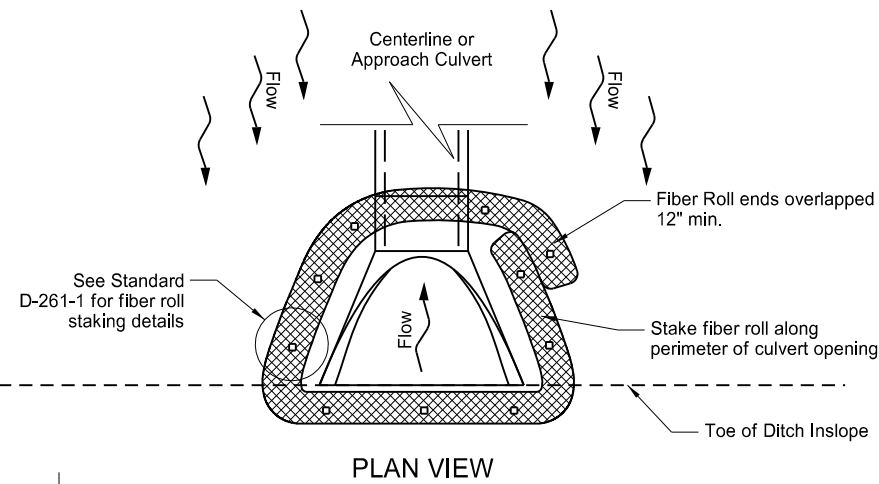

FIBER ROLL PROTECTION (INLET OF CULVERT)

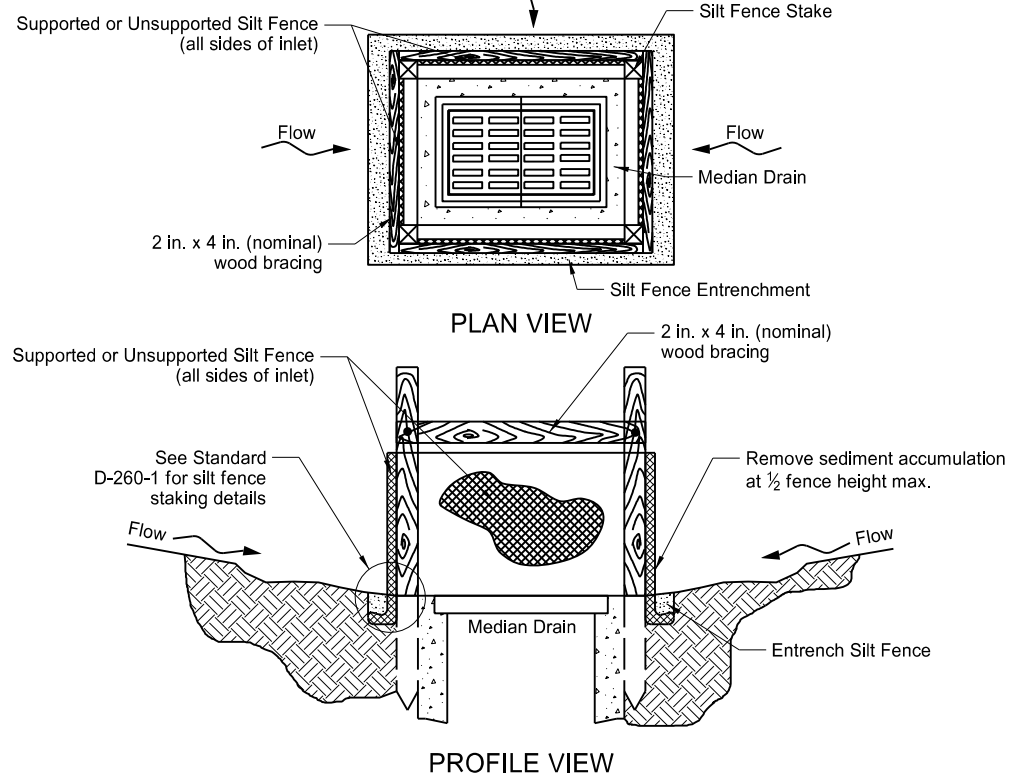

SILT FENCE PROTECTION (MEDIAN OR DITCH INLET)

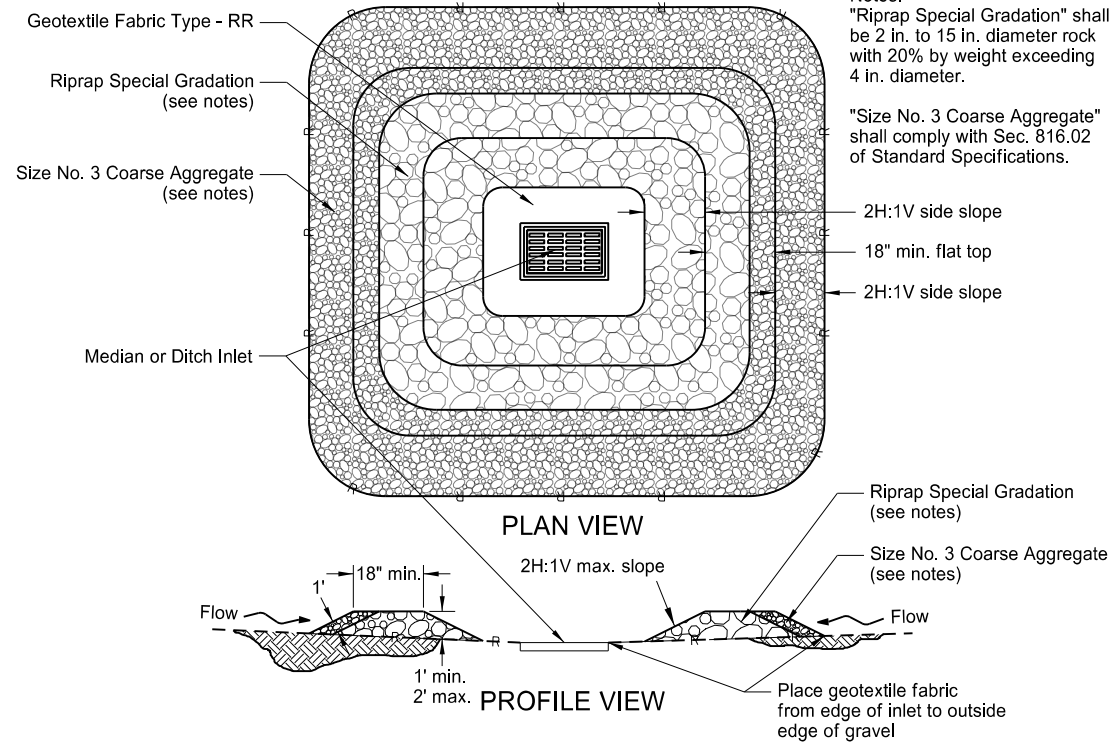

GRAVEL INLET PROTECTION (MEDIAN OR DITCH INLET)

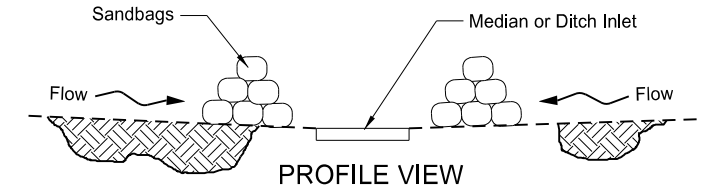
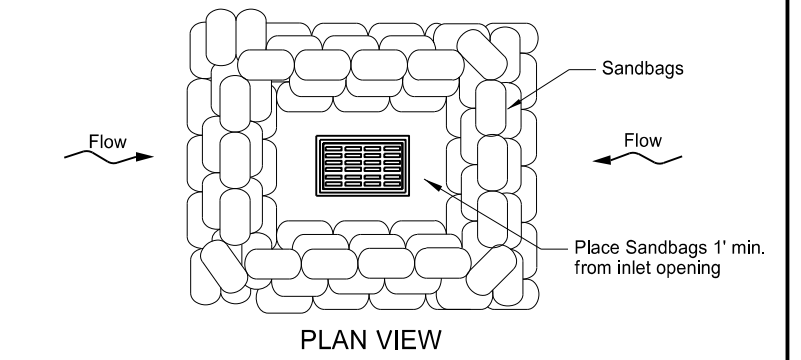

SANDBAG PROTECTION (LOW POINT)

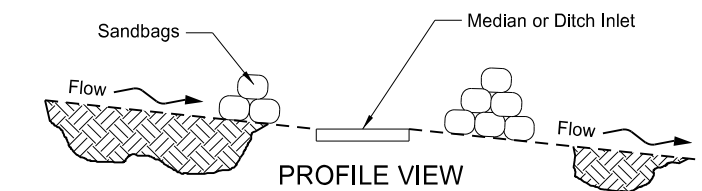
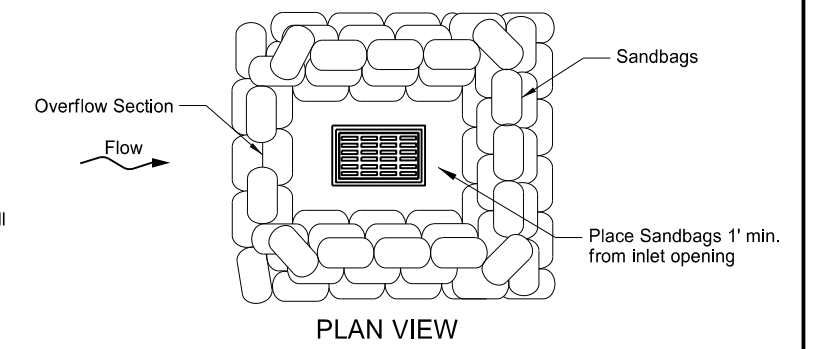

SANDBAG PROTECTION (ON SLOPE)

NORTH DAKOTA DEPARTMENT OF TRANSPORTATION	
10-03-13	
REVISIONS	
DATE	CHANGE
06-26-14	Updated reference to standard drawing number for fiber roll staking details.
10-01-14	Updated reference to standard drawing number for silt fence.

This document was originally issued and sealed by  
**Roger Weigel**  
Registration Number  
**PE-2930**,  
on 10/01/14 and the original document is stored at the North Dakota Department of Transportation