

DESIGN DATA			
Traffic		Average Daily	
Current 2020	Pass: 375	Trucks: 50	Total: 425
Preventive Maintenance			

STATE	PROJECT NO.	PCN	SECTION NO.	SHEET NO.
ND	H-8-127(010)000	23026	1	1

NORTH DAKOTA DEPARTMENT OF TRANSPORTATION

H-8-127(010)000
Richland County
ND 127 From South Dakota Line To ND 11
Chip Seal

GOVERNING SPECIFICATIONS	Date Published and Adopted by the North Dakota Department of Transportation
Standard Specifications	10/1/2020
Supplemental Specifications	NONE

PROJECT NUMBER \ DESCRIPTION	NET MILES	GROSS MILES
H-8-127(010)000	7.980	7.984

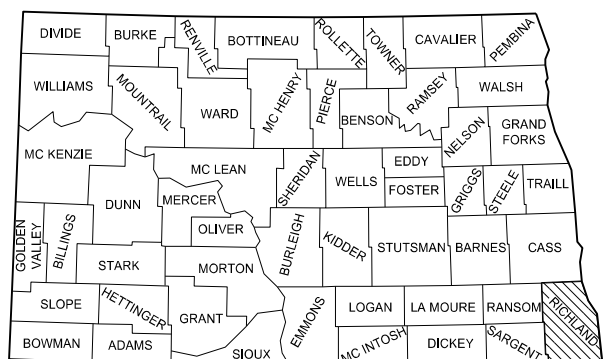

STATE COUNTY MAP

DESIGNER Aaron Kelsch
DESIGNER
DESIGNER

ND DEPARTMENT OF TRANSPORTATION FARGO DISTRICT	10/12/20
Joe Peyer /s/	

NDDOT FARGO DISTRICT

This document was originally issued and sealed by
Duane Carlstrom
Registration Number
PE- 5832 ,
on 10/12/20 and the original document is stored at the
North Dakota Department
of Transportation

TABLE OF CONTENTS

	STATE	PROJECT NO.	SECTION NO.	SHEET NO.
	ND	H-8-127(010)000	2	1

PLAN SECTIONS

Section	Page(s)	Description
1	1	Title Sheet
2	1	Table of Contents
6	1	Notes
8	1	Quantities
10	1	Basis of Estimate
20	1	General Details
30	1	Typical Sections
100	1-2	Work Zone Traffic Control
120	1	Pavement Marking

LIST OF STANDARD DRAWINGS

Number	Description
D-101-1, 2, 3, 4	NDDOT Abbreviations
D-101-10	NDDOT Utility Company and Organization Abbreviations
D-101-20, 21	Line Styles
D-101-30, 31, 32, 33	Symbols
D-704-3	Lane Markers (Spotting Tab For Seal Projects Only)
D-704-7	Breakaway Systems For Construction Zone Signs - Perforated Tube
D-704-8	Breakaway Systems For Construction Zone Signs - U-Channel Post
D-704-9	Construction Sign Details - Terminal And Guide Signs
D-704-10	Construction Sign Details - Regulatory Signs
D-704-11, 11A	Construction Sign Details - Warning Signs
D-704-13	Barricade And Channelizing Device Details
D-704-14	Construction Sign Punching And Mounting Details
D-704-15	Road Closure Layouts
D-704-20	Terminal And Seal Coat Sign Layouts
D-704-22	Construction Truck And Temporary Detour Layouts
D-704-27	Mobile Operation (Pavement Marking)
D-704-50	Portable Sign Support Assembly
D-762-4	Pavement Marking
D-762-5	Pavement Marking for Standard 90 Degree Flared Intersection-(No Center Left Turn Lane on Major Road)
D-762-11	Short-Term Pavement Marking

SPECIAL PROVISIONS

Number	Description
PSP 29(20)	Permits and Environmental Considerations

STATE	PROJECT NO.	SECTION NO.	SHEET NO.
ND	H-8-127(010)000	6	1

NOTES

401-P01 FOG SEAL: Apply a fog seal to the shoulders and sloughs a minimum of 1 day before applying seal oil and chips. Apply the fog seal using an emulsified asphalt at a rate of 0.12 gallons per square yard.

420-P01 BLOTTER MATERIAL CL 44: In addition to preventing bleeding on the roadway etc., apply blotter material to all major intersections for maintenance, bleeding, and protection of the chips/asphalt from turning movements. An estimated 20 ton is provided. A mechanical tailgate spreader will be used and be situated on the project prior to start of the seal.

420-P02 BITUMEN: Apply the bituminous seal coat materials at a rate such that the average aggregate embedment is 70 percent of the residual asphalt binder material.

420-P03 COVER COAT MATERIAL CL 41-M: Within one minute following the application of the bitumen, spread the cover coat material uniformly over the bituminous material with an aggregate spreader. Tightly pack cover coat material so that small voids caused by irregular shapes of the aggregate particles are filled with residual asphalt.

The acceptance of the cover coat material will be as follows:
The Engineer will collect and test three samples for each lot of material. A lot is defined as 96,000 SY. If the final lot is less than 48,000 SY, the Engineer will include it in the previous lot, if greater than 48,000 SY, the Engineer will sample it as a separate lot. If the average of the three samples does not meet the gradation specified, the Engineer will either reduce the contract unit price, as **specified in Section 420.06, "Basis of Payment", or reject the material. Do not** incorporate the additional material if two consecutive lots deviate from the gradation. Restart placement operations after taking corrective actions and passing a gradation test.

420-P04 CHFRS-2P EMULSIFIED ASPHALT: Use an Emulsified Asphalt with a modified minimum penetration of 90 for the test on residue from distillation. Styrene Butadiene Rubber latex polymer shall be added to the water/soap phase by injection prior to the mill manufacture of the asphalt emulsion by emulsion producer. The amount of solid from the latex polymer shall be at least 3% of the asphalt residual content and shall be certified by the emulsion producer on each load of emulsion delivered to the job site.

420-P05 APPROACHES: Unless changes are made in the field, approaches on the project will be counted and the plan quantities identified in Section 20, Sheet 1 for each type of approach will be used for the following bid item:
1. Cover Coat Material CL 41-M (SY)

704-500 PORTABLE RUMBLE STRIPS (PRS): Use PRS made of rubber or engineered polymers.

Install PRS as part of the temporary traffic control when the following signs are also part of the required traffic control set up:

- "Be Prepared to Stop" (W3-4); and

- "Flagger" symbol (W20-7)

Install PRS that meet the following criteria:

- Have no adhesives or fasteners required for placement;
- Have a manufacture's speed rating that meets or exceeds the posted speed limit; and
- Each strip in the array must weigh a minimum of 100 pounds.

Use individual PRS constructed in one of the following manners:

- A single piece;
- Inter locking segments; or
- Two pieces hinged at the midpoint.

An installed array of PRS consists of a minimum of 3 individual strips.

Move rumble strips with the flagging operation. Do not place rumble strips on horizontal curves.

The Engineer will count and measure each array as one unit. Include the cost of providing, installing, maintaining, and relocating PRS in the unit price bid for "Portable Rumble Strips".

704-P01 TRAFFIC CONTROL FOR SEAL COATS: Provide traffic control consisting of a temporary lane closure, flagging, and a pilot car.

Traffic control device quantities are based on a 6 mile limitation and following list:

- Standard D-704-15, layout A, place layout A at both ends of the work zone. Flagging stations located within the work zone require sign W20-7-48 only;
- Standard D-704-20, layout H, signing will be required at: Richland County 22.
- Standard D-704-22, layouts K and L.

Provide additional devices at no cost to the Department.
Place flaggers and traffic control devices as shown on Standard D-704-15, layout A at the following intersections when the lane closure spans across them:

- Richland County 22

704-P02 OBLITERATION OF PAVEMENT MARKINGS: Do not obliterate pavement markings more than one day prior to starting the chip seal.

762-P01 PAVEMENT MARKING: Plan quantity will be used as the **measurement for payment for "Short Term Painted Line-Seal Jobs" and "Pvmt Mk Painted 4IN Line"** unless changes are made in the field.

762-P02 PREFORMED PATTERNED PVMT MK 24IN LINE – GROOVED: Groove and install preformed patterned pavement markings a minimum of 14 days after the application of the seal coat.

This document was originally issued and sealed by Duane Carlstrom, Registration Number PE-5832, on 10/12/20 and the original document is stored at the North Dakota Department of Transportation.

ESTIMATE OF QUANTITIES

STATE	PROJECT NO.	SECTION NO.	SHEET NO.
ND	H-8-127(010)000	8	1

SPEC CODE	ITEM DESCRIPTION	UNIT	MAINLINE	TOTAL
-----	-----	-----	-----	-----
103	0100 CONTRACT BOND	L SUM	1	1
401	0070 FOG SEAL	GAL	1,314	1,314
420	0118 CHFRS-2P EMULSIFIED ASPHALT	GAL	51,997	51,997
420	0128 COVER COAT MATERIAL CL 41-M	SY	126,820	126,820
420	0160 BLOTTER MATERIAL CL 44	TON	20	20
702	0100 MOBILIZATION	L SUM	1	1
704	1000 TRAFFIC CONTROL SIGNS	UNIT	1,834	1,834
704	1048 PORTABLE RUMBLE STRIPS	EA	2	2
704	1500 OBLITERATION OF PAVEMENT MARKING	SF	48	48
762	0460 SHORT TERM PAINTED LINE-SEAL JOBS	LF	18,443	18,443
762	1104 PVMT MK PAINTED 4IN LINE	LF	103,280	103,280
762	1108 PVMT MK PAINTED 8IN LINE	LF	173	173
762	1124 PVMT MK PAINTED 24IN LINE	LF	14	14
762	1325 PREFORMED PATTERNED PVMT MK 24IN LINE-GROOVED	LF	12	12

LOCATION	ROADWAY LENGTHS/WIDTHS			CHIP SEAL					FOG SEAL		
				CHFRS-2P EMULSIFIED ASPHALT @ 0.41 GAL/SY		COVER COAT MATERIAL CL 41-M @ (25 LBS/SY*)			SS-1H, MS-1 or CSS-1H EMULSIFIED ASPHALT @ 0.12 GAL/SY (0.06 GAL/SY UNDILUTED)		
				LF	MILE	WIDTH	GAL/MILE	TOTAL GAL	TON/MILE	TOTAL TONS*	TOTAL SY
RP 0.000 to RP 7.933	41,865	7.929	27'	6,494.4	51,494	198.0*	1,570*	125,595	4'	140.8	1,116

*For Information Only

ADDITIONAL SURFACING QUANTITIES		EACH	SY	CHIP SEAL			FOG SEAL	
				CHFRS-2P @0.41 GAL/SY	COVER COAT MATERIAL CL 41-M		SS-1H, MS-1 or CSS-1H EMULSIFIED ASPHALT @ 0.12 GAL/SY (0.06 GAL/SY UNDILUTED)	
				TOTAL GAL	TOTAL SY	(25 LBS/SY*)	TOTAL SY	TOTAL GAL
(1) Paved Section Line, County Road, or Street Approach	See Section 20 Sheet 1	1	275	113	275	3.4 Ton*		
(2) Gravel Section Line, County Road, or Street Approach	See Section 20 Sheet 1	13	160				2,080	125
(3) Gravel Private Drive or Field Drive Approach	See Section 20 Sheet 1	45	25				1,125	68
(4) Jct. ND 127 & ND 11	See Section 20 Sheet 1	1	950	390	950	11.9 Ton*	90	5
TOTAL								

*For Information Only

PAVEMENT MARKING QUANTITIES	LF/MILE	QUANTITY
Short Term Painted Line-Seal Jobs RP 0.000 to RP 7.984:		
4" Yellow C Skips: 10' Line, 30' Skip	1320	10,539 LF
4" Yellow Barrier Stripe	990	7,904 LF
	Total	18,443 LF
Pvmt Mk Painted 4IN Line RP 0.000 to RP 7.933:		
4" Yellow C Skips: 10' Line, 30' Skip	1320	10,472 LF
4" Yellow Barrier Stripe	990	7,854 LF
4" White Edge Line	10560	83,772 LF
	Total	102,098 LF
RP 7.933 to RP 7.984: See Sec. 120 Sht.1		
Pvmt Mk Painted 24IN Line: (Stop Bar on CR 22 @ Jct. w/ ND 127)	Total	14 LF

This document was originally issued and sealed by Duane Carlstrom Registration Number PE- 5832, on 10/12/20 and the original document is stored at the North Dakota Department of Transportation

Basis of Estimate

STATE	PROJECT NO.	SECTION NO.	SHEET NO.
ND	H-8-127(010)000	20	1

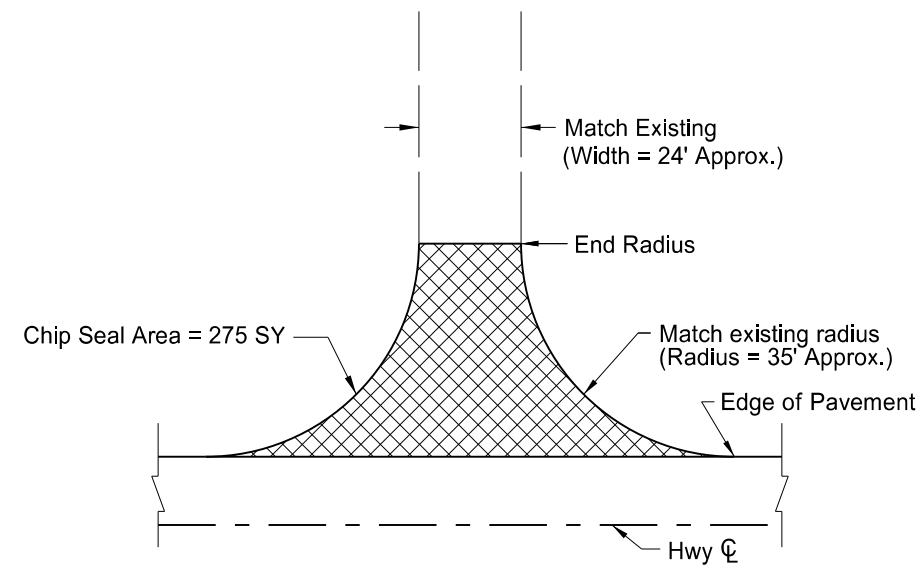

(1) Paved Section Line, County Road, or Street Approach

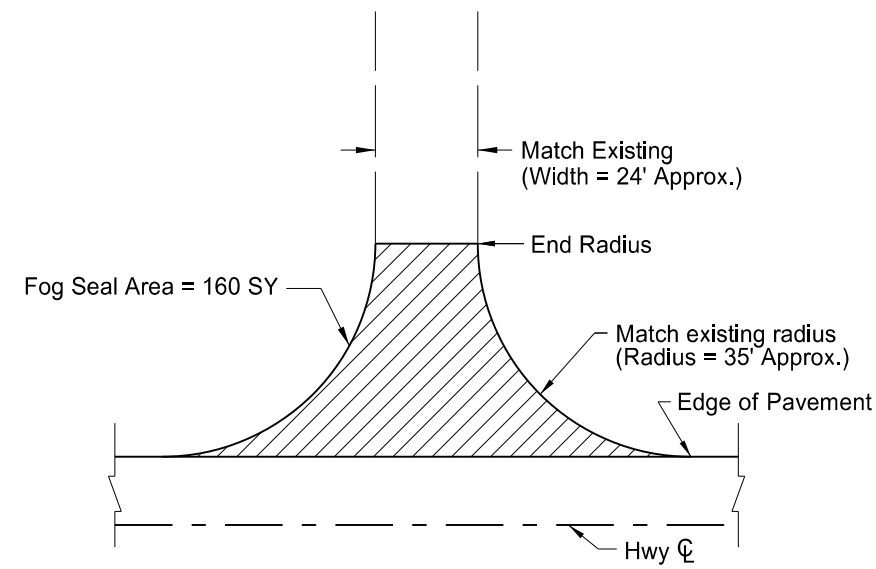

(2) Gravel Section Line, County Road, or Street Approach

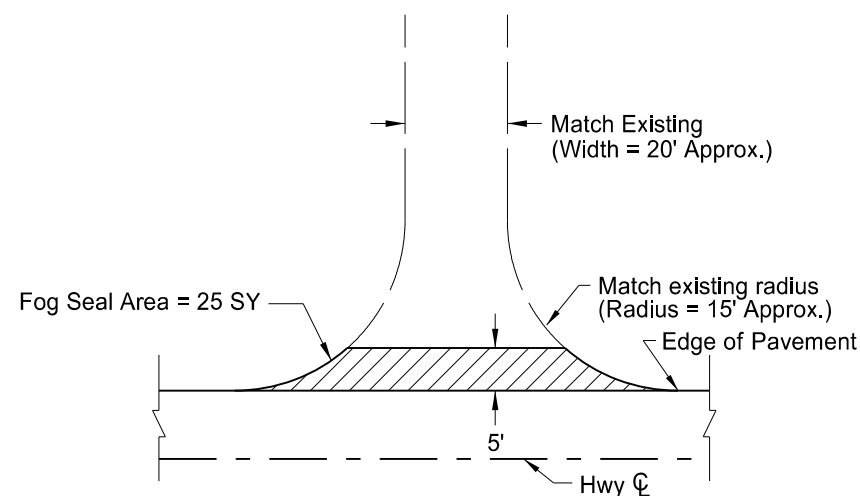
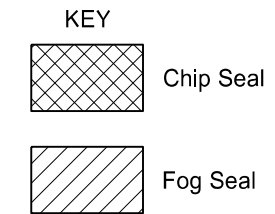

(3) Gravel Private Drive or Field Drive Approach

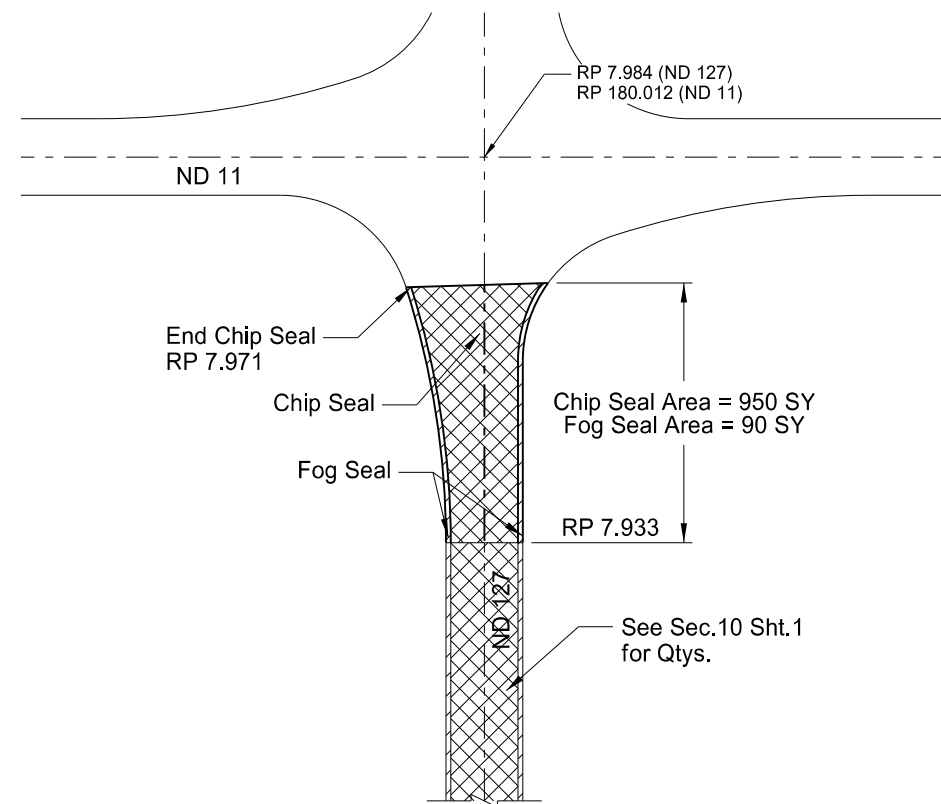

(4) Jct. ND 127 and ND 11

This document was originally issued and sealed by Duane Carlstrom Registration Number PE- 5832, on 10/12/20 and the original document is stored at the North Dakota Department of Transportation

Approach and Intersection Details

DRAWING NOT TO SCALE

	STATE	PROJECT NO.	SECTION NO.	SHEET NO.
	ND	H-8-127(010)000	30	1

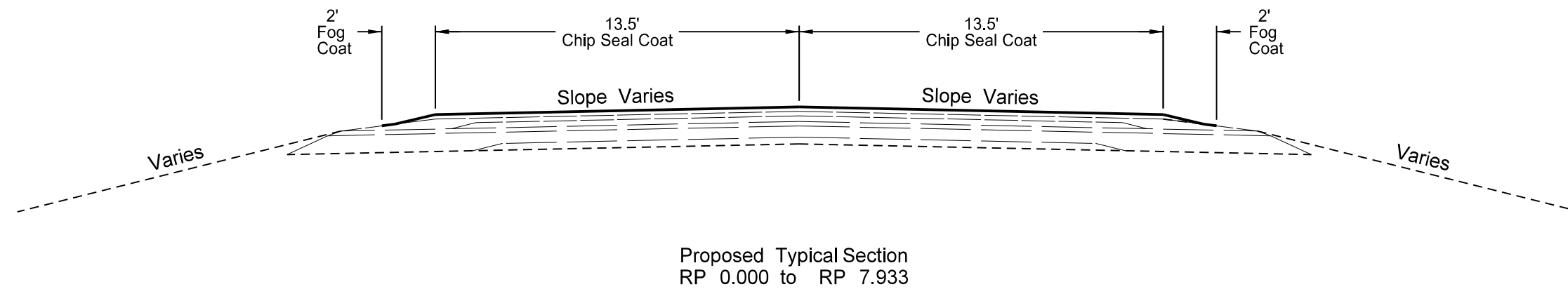
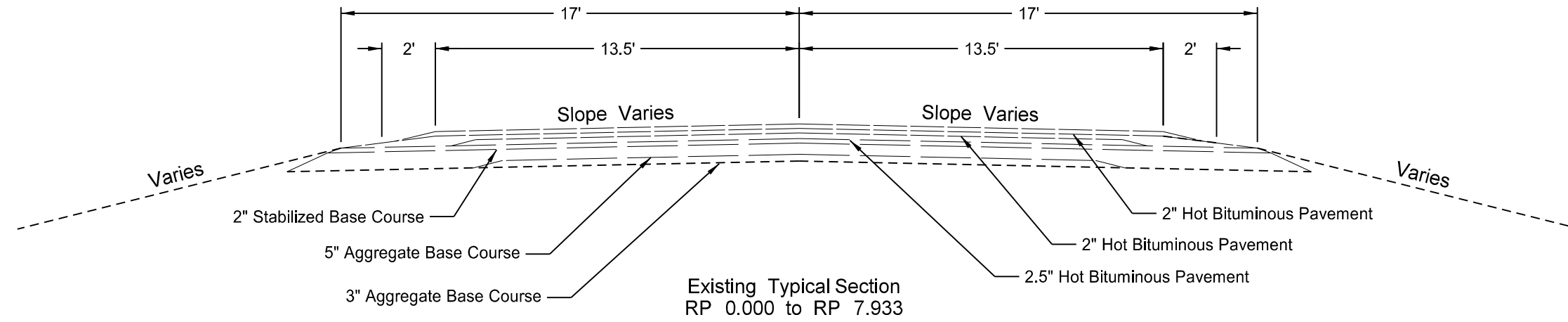

This document was originally issued and sealed by Duane Carlstrom Registration Number PE- 5832 , on 10/12/20 and the original document is stored at the North Dakota Department of Transportation

Typical Sections

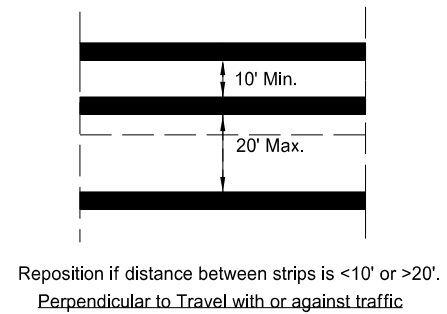
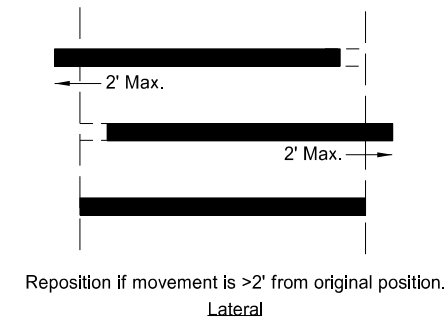
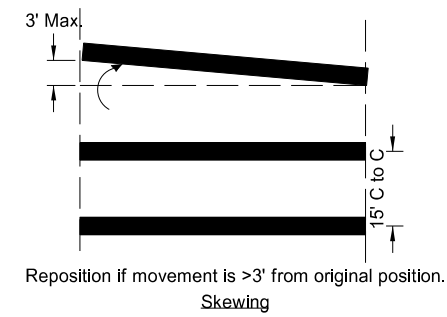

**PORTABLE RUMBLE STRIPS ARRAY
TYPES OF MOVEMENT AND MAXIMUM ALLOWANCES**

Notes:

1. Number of devices were calculated using 40 mph. Speed determined in the field based on location and conditions.
2. Re-establish the speed limit. Determine the exact speed limit in the field, dependent on location and conditions.
3. Sign R2-1aP-24 is not required when pilot car operation is used.
4. Rumble strips are not used on a non paved surface or in a pre-construction speed zone of 25 mph or less.

Road Type	ADVANCE WARNING SIGN SPACING		
	Distance Between Signs Min. (ft)		
	A	B	C
Urban - Low Speed (30 mph or less)	150	150	150
Urban - Low Speed (over 30 to 40 mph)	280	280	280
Urban - High Speed (over 40 mph to 50 mph)	360	360	360
Rural - High Speed (over 50 mph to 65 mph)	720	720	720

This document was originally issued and sealed by
Duane Carlstrom
Registration Number
PE- 5832,
on 10/12/20 and the original document is stored at the
North Dakota Department
of Transportation

TWO-LANE PORTABLE RUMBLE STRIPS

KEY

- Work area
- Flagger
- Sign
- S = Numerical value of speed limit or 85th percentile.

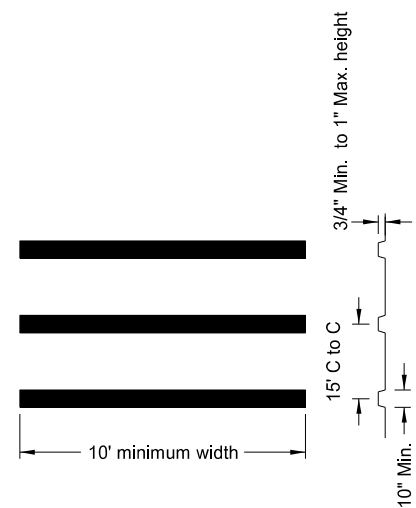
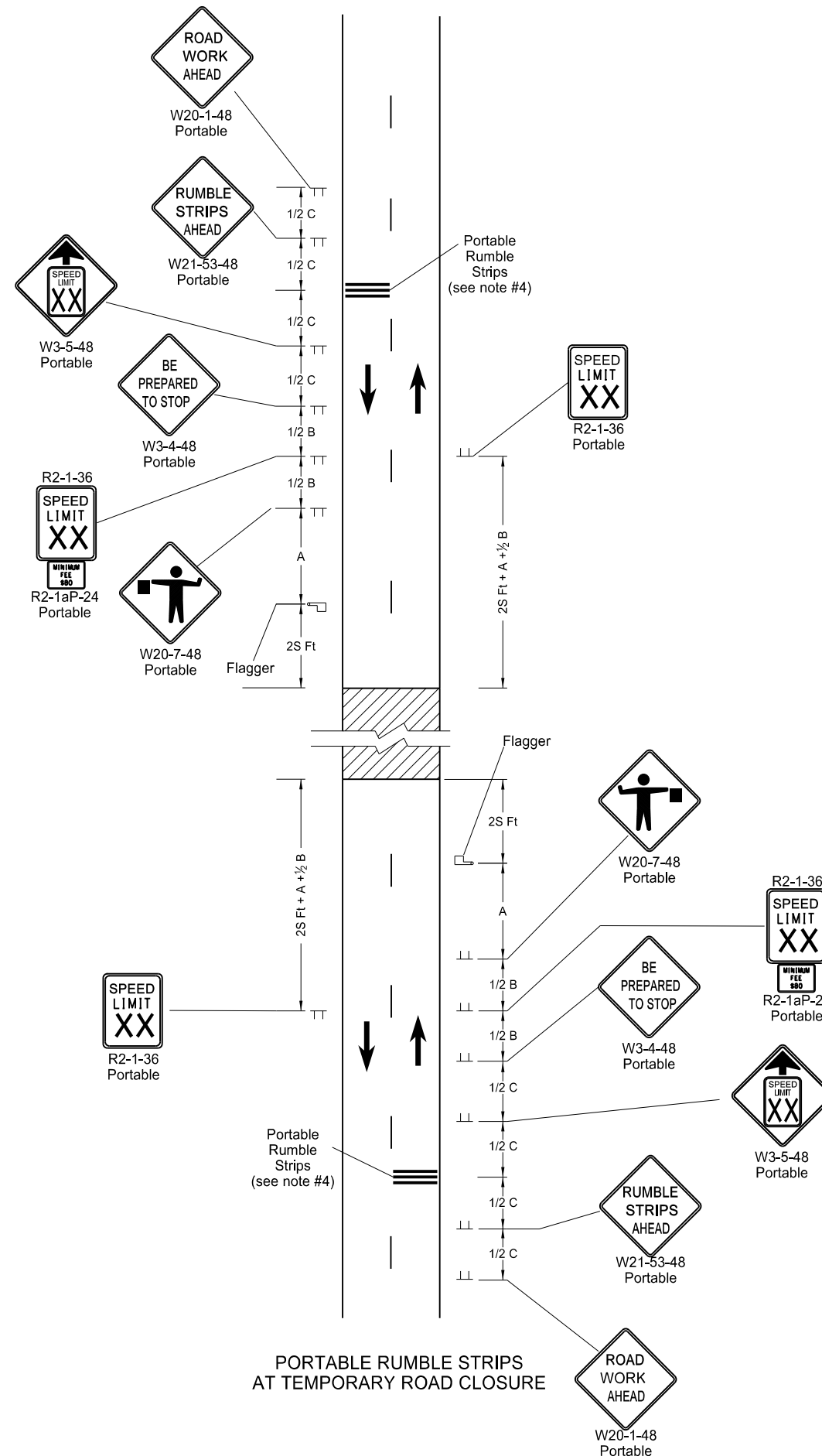

PORTABLE RUMBLE STRIPS ARRAY DETAIL

**PORTABLE RUMBLE STRIPS
AT TEMPORARY ROAD CLOSURE**

STATE	PROJECT NO.	SECTION NO.	SHEET NO.
ND	H-8-127(010)000	120	1



704	1500 OBLITERATION OF PAVEMENT MARKING		
	Existing 24" Stop Bar	48	SF
762	1104 PVMT MK PAINTED 4IN LINE		
	White Edge Line	696	LF
	Double Yellow Barrier	486	LF
	Total =	1182	LF
762	1108 PVMT MK PAINTED 8IN LINE		
	White Chevrons	173	LF
762	1325 PREF PATT PVMT MK 24IN LINE GROOVED		
	White Stop Bar	12	LF

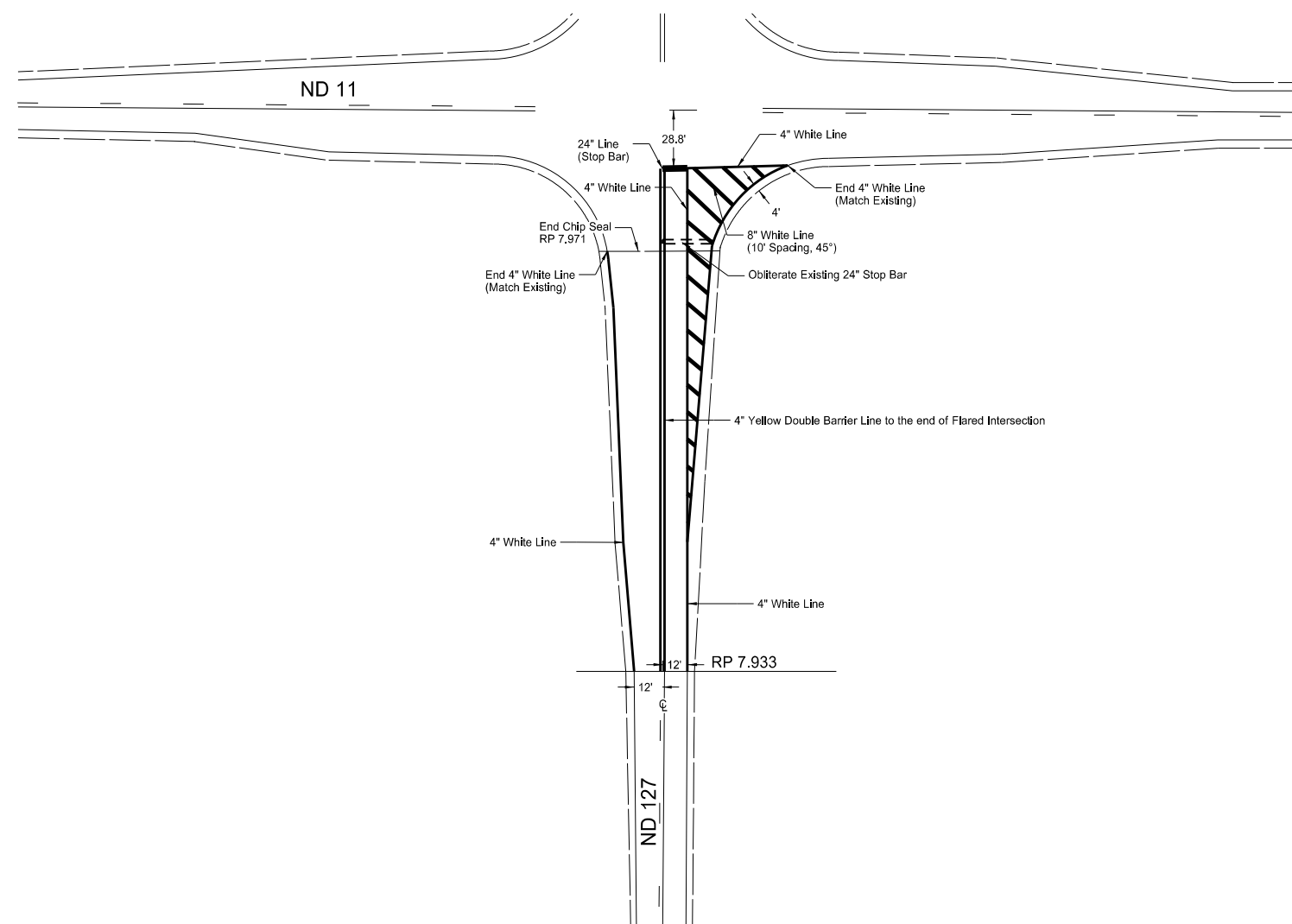

This document was originally issued and sealed by Duane Carlstrom Registration Number PE- 5832 , on 10/12/20 and the original document is stored at the North Dakota Department of Transportation

Pavement Marking Layout
RP 7.933 to Jct ND 11

NDDOT ABBREVIATIONS

? This is a special text character used in the labeling of existing features. It indicates a feature that has an unknown characteristic, potentially based on: lack of description, location accuracy or purpose.

Abn abandoned
 Abut abutment
 Adj adjusted
 Aggr aggregate
 Ahd ahead
 ARV air release valve
 Align alignment
 Al alley
 Alt alternate
 Alum aluminum
 ADA Americans with Disabilities Act
 & and
 Appr approach
 Approx approximate
 ACP asbestos cement pipe
 Asph asphalt
 AC asphalt cement
 Assmd assumed
 @ at
 Atten attenuation
 ATR automatic traffic recorder
 Ave Avenue
 Avg average
 ADT average daily traffic

Bk back
 BF back face
 Balc balcony
 B Wire barbed wire
 Barr barricade
 Btry battery
 BI beehive inlet
 Beg begin
 BG below grade
 BM bench mark
 Bkwy bikeway
 Bit bituminous
 Blk block
 BH bore hole
 Bot bottom
 Blvd Boulevard
 Bndry boundary
 Brkwy breakaway
 Br bridge
 Bldg building
 Bus. business
 BV butterfly valve
 Byp bypass

C Gdrl cable guardrail
 Calc calculate
 CIP cast iron pipe
 CB catch basin
 CRS cationic rapid setting
 C Gd cattle guard
 C To C center to center
 CL or C centerline
 Ch chain
 Chnlk chain-link
 Ch Blk channel block
 Ch Ch channel change
 Chk check
 Chsld chiseled
 Cir circle
 Cl class
 Clnt clean-out
 Clr clear
 Cl&gr clearing & grubbing
 Comb. combination
 Coml commercial
 Compr compression
 CADD computer aided drafting & design
 Conc concrete
 CECB concrete erosion control blanket
 Cond conductor
 Const construction
 Cont continuous
 CSB continuous split barrel sample
 Contr contraction
 Contr contractor
 CP control point
 Coord coordinate
 Cor corner
 Corr corrected
 CAES corrugated aluminum end section
 CAP corrugated aluminum pipe
 CMES corrugated metal end section
 CMP corrugated metal pipe
 CPVCP corrugated poly-vinyl chloride pipe
 CSES corrugated steel end section
 CSFES corrugated steel flared end section
 CSP corrugated steel pipe
 CSTES corrugated steel traversable end section
 Co County
 Crse course
 Ct Court
 Xarm cross arm
 Xbuck cross buck
 Xsec cross sections
 Xing crossing
 Xrd crossroad
 Crn crown

Culv culvert
 C&G curb & gutter
 CI curb inlet
 CR curb ramp
 C cut
 Dd Ld dead load
 Defl deflection
 Defm deformed
 DInt delineate
 DIntr delineator
 Depr depression
 Desc description
 Det detail
 DWP detectable warning panel
 Dtr detour
 Dia or \emptyset diameter
 Dir direction
 Dist distance
 DM disturbed material
 DB ditch block
 DG ditch grade
 Dbl double
 Dn down
 Dwg drawing
 Dr drive
 Drwy driveway
 DI drop inlet
 D dry density
 DSDS dynamic speed display sign

Ea each
 Esmt easement
 E East
 EB Eastbound
 Elast elastomeric
 EL electric locker
 E Mtr electric meter
 Elec electric/al
 EDM electronic distance meter
 Elev or El elevation
 Ellipt elliptical
 Emb embankment
 Emuls emulsion/emulsified
 ES end section
 Engr engineer
 ESS environmental sensor station
 Eq equal
 Evgr evergreen
 Exc excavation
 Exst existing
 Exp expansion
 Expy Expressway
 E external of curve
 Extru extruded

FOS factor of safety
 Fed Federal
 FP feed point
 Fn fence
 Fn P fence post
 FO fiber optic
 FD field drive
 F fill
 FAA fine aggregate angularity
 FH fire hydrant
 Fl flange
 Flrd flared
 FES flared end section
 F Bcn flashing beacon
 FA flight auger sample
 FL flow line
 Ftg footing
 FM force main
 Fnd found
 Fdn foundation
 Frac fractional
 Frwy freeway
 Frt front
 FF front face
 F Disp fuel dispenser
 FFP fuel filler pipes
 FLS fuel leak sensor
 Furn furnish/ed

NORTH DAKOTA DEPARTMENT OF TRANSPORTATION	
07-01-14	
REVISIONS	
DATE	CHANGE
04-23-18	General Revisions
09-20-18	General Revisions
12-18-20	General Revisions



NDDOT ABBREVIATIONS

Galv	galvanized	Ln	lane	Obsc	obscure(d)	Qty	quantity
Gar	garage	Lg	large	Ocpd	occupied	Qtr	quarter
Gs L	gas line	Lat	latitude	Ocpy	occupy		
G Reg	gas line regulator	Lt	left	O/s	offset		
GMV	gas main valve	Lens	lenses	OC	on center	Rad or R	radius
G Mtr	gas meter	Lvl	level	C	one dimensional consolidation	RR	railroad
GSV	gas service valve	LvIng	leveling	OC	organic content	Rlwy	railway
GVP	gas vent pipe	Lht	light	Orig	original	Rsd	raised
GV	gate valve	LP	light pole	O To O	out to out	RC	rapid curing
Ga	gauge	Ltg	lighting	OD	outside diameter	Rec	record
Gov	government	Liq	liquid	OH	overhead	Rcy	recycle
Grd	graded/grade	LL	liquid limit			RAP	recycled asphalt pavement
Gmnd	ground	Loc	location			RPCC	recycled portland cement concrete
GWM	ground water monitor	Long.	longitude	PMT	pad mounted transformer	Ref	reference
Gdrl	guardrail	Lp	loop	Pg	pages	R Mkr	reference marker
Gtr	gutter	LD	loop detector	Pntd	painted	RM	reference monument
		Lum	luminaire	Pr	pair	RP	reference point
				Pnl	panel	Refl	reflectorized
				Pk	park	RCB	reinforced concrete box
H Plg	H piling	Mb	mailbox	PSD	passing sight distance	RCES	reinforced concrete end section
Hdwl	headwall	ML	main line	Pvmt	pavement	RCFES	reinforced concrete flared end section
Ht	height	MH	manhole	Ped	pedestal	RCP	reinforced concrete pipe
Hel	helical	Mkd	marked	Ped	pedestrian	RCPS	reinforced concrete pipe sewer
HDPE	high density polyethylene	Mkr	marker	PPP	pedestrian pushbutton post	RCTES	reinforced concrete traversable end section
HM	high mast	Mkg	marking	Pen.	penetration	Reinf	reinforcement
HP	high pressure	MA	mast arm	Perf	perforated	Res	reservation
HPS	high pressure sodium	Matl	material	Per.	perimeter	Res	residence
Hwy	highway	Max	maximum	Perm	permanent	Ret	retaining
Hor	horizontal	MC	meander corner	PL	pipeline	Rev	reverse
HBP	hot bituminous pavement	Meas	measure	PI	place	Rt	right
HMA	hot mix asphalt	Mdn	median	P&P	plan & profile	R/W	right of way
Hyd	hydrant	MD	median drain	PL	plastic limit	Riv	river
Ph	hydrogen ion content	MC	medium curing	PI or P _L	plate	Rd	road
		MGS	Midwest Guardrail System	Pt	point	Rdbd	road bed
		MM	mile marker	PE	polyethylene	Rdwy	roadway
Id	identification	MP	mile post	PVC	polyvinyl chloride	RWIS	roadway weather information system
Incl	inclinometer tube	Min	minimum	PCC	Portland Cement concrete	Rk	rock
IMH	inlet manhole	Misc	miscellaneous	PP	power pole	Rt	route
ID	inside diameter	Mon	monument	Preempt	preemption		
Inst	instrument	Mnd	mound	Prefab	prefabricated		
Intchg	interchange	Mtd	mountable	Prfmd or Pref	performed		
Intmdt	intermediate	Mtbl	mountable	Prep	preparation		
Intscn	intersection	Mtd	mounted	Press.	pressure		
Inv	invert	Mtg	mounting	PRV	pressure relief valve		
IP	iron pipe	Mk	muck	Prestr	prestressed		
				Pvt	private		
				PD	private drive		
Jt	joint	Neop	neoprene	Prod.	production/produce		
Jct	junction	Ntwk	network	Prog	programmed		
		N	North	Prop.	property		
		NE	North East	Prop Ln	property line		
		NW	North West	Ppsd	proposed		
		NB	Northbound	PB	pull box		
		No. or #	number				

NORTH DAKOTA DEPARTMENT OF TRANSPORTATION	
07-01-14	
REVISIONS	
DATE	CHANGE
08-03-15	General Revisions
04-23-18	General Revisions
12-18-20	General Revisions

KIRK J. HOFF
REGISTERED
PROFESSIONAL
PE-4683
ENGINEER
NORTH DAKOTA
12 18 2020

NDDOT ABBREVIATIONS

D-101-3

Salv	salvage(d)	Tel	telephone
San	sanitary sewer line	Tel B	Telephone Booth
Sec	section	Tel P	telephone pole
SL	section line	Tv	television
Sep	separation	Temp	temperature
Seq	sequence	Temp	temporary
Serv	service	TBM	temporary bench mark
Sht	sheet	T	thinwall tube sample
Shtng	sheeting	Ts	topsoil
Shldr	shoulder	Traf	traffic
Sw or Sdwk	sidewalk	TSCB	traffic signal control box
SD	sight distance	Tr	trail
SN	sign number	Transf	transformer
Sig	signal	Trans	transition
Sgl	single	TT	transmission tower
SRCP	slotted reinforced concrete pipe	TES	traversable end section
SC	slow curing	Trans	transverse
SS	slow setting	Trtd	treated
Sm	small	Trmt	treatment
S	South	Qc	triaxial compression
SE	South East	TERO	tribal employment rights ordinance
SW	South West	Tpl	triple
SB	Southbound	Typ	typical
Sp	spaces		
Spcl	special	Qu	unconfined compressive strength
SA	special assembly	Ugrnd	underground
SP	special provisions	Util	utility
G	specific gravity		
Spk	spike	VG	valley gutter
SB	split barrel sample	Vap	vapor
SH	sprinkler head	Vert	vertical
SV	sprinkler valve	VCP	vitrified clay pipe
Sq	square	Vol	volume
Stk	stake		
Std	standard	Wkwy	walkway
N	standard penetration test	W	water content
Std Specs	standard specifications	WGV	water gate valve
Stm L	steam line	WL	water line
SEC	steel encased concrete	WM	water main
SMA	stone matrix asphalt	WMV	water main valve
SSD	stopping sight distance	W Mtr	water meter
SD	storm drain	WSV	water service valve
St	street	WW	water well
SPP	structural plate pipe	Wrng	wearing
SPPA	structural plate pipe arch	WIM	weigh in motion
Str	structure	W	west
Subd	subdivision	WB	westbound
Sub	subgrade	Wrng	wiring
Sub Prep	subgrade preparation	W/	with
Ss	subsoil	W/o	without
SS	supplement specification	WC	witness corner
Supp	supplemental		
Surf	surfacing		
Surv	survey		
Sym	symmetrical		

NORTH DAKOTA DEPARTMENT OF TRANSPORTATION	
07-01-14	
REVISIONS	
DATE	CHANGE
08-03-15	General Revisions
04-23-18	General Revisions
12-18-20	General Revisions



12 18 2020

MEASUREMENTS

ac acres
 A ampere
 Bd Ft board feet
 Cd candela
 cm centimeter
 C coulomb
 CF cubic feet
 m3 cubic meter
 m3/s cubic meters per second
 CY cubic yard
 CY/mi cubic yards per mile
 D or Deg degree
 F Fahrenheit
 F farad
 ft feet/foot
 Gal gallon
 G giga
 Ha hectare
 H henry
 Hz hertz
 hr hour(s)
 in inch
 J joule
 K kelvin
 kN kilo newton
 kPa kilo pascal
 kg kilogram
 kg/m3 kilogram per cubic meter
 km kilometer
 K Kip(s)
 LF linear foot
 L litre
 Lm lumen
 L sum lump sum
 Lx lux
 M Hr man hour
 M mega
 m meter
 m/s meters per second
 mi mile
 mL milliliter
 mm millimeter
 mm/hr millimeters per hour
 n nano
 N newton
 Pa pascal
 lb pounds
 sec seconds
 S siemens
 SF square feet
 km2 square kilometer
 m2 square meter
 SY square yard
 Sta Yd station yards
 SI Systems International

T tesla
 T/mi tons per mile
 V volt
 W watt
 Wb weber

SURVEY DESCRIPTIONS

Az azimuth
 Bs backsight
 Brg bearing
 BP Cap blue plastic cap
 BS both sides
 BC brass cap
 CS curve to spiral
 Eq equation
 E external of curve
 FS far side
 FB field book
 Fs foresight
 Geod geodetic
 GIS Geographical Information System
 GPS Global Positioning System
 HI height of instrument
 IM iron monument
 I Pn iron pin
 LS Land Surveyor (licensed)
 LSIT Land Surveyor In Training
 L length of curve
 LC long chord
 LB level book
 Mer meridian
 M mid ordinate of curve
 NGS National Geodetic Survey
 NS near side
 Obsn observation
 Off Loc office location
 OP Cap orange plastic cap
 PK Parker-Kalon nail
 P Cap plastic cap
 PP Cap pink plastic cap
 PCC point of compound curve
 PC point of curve
 PI point of intersection
 PRC point of reverse curvature
 PT point of tangent
 POC point on curve
 POT point on tangent
 RTP random traverse point
 Rge range
 RP Cap red plastic cap
 SC spiral to curve
 ST spiral to tangent
 Sta station
 SE superelevation
 Tan tangent
 T tangent (semi)
 TS tangent to spiral
 Twp township
 TB transit book
 TP traverse point
 TP turning point
 USC&G US Coast & Geodetic Survey
 USGS US Geologic Survey
 VC vertical curve
 WGS World Geodetic System
 YP Cap yellow plastic cap
 Z zenith

SOIL TYPES

Cl clay
 Cl F clay fill
 Cl Hvy clay heavy
 Cl Lm clay loam
 Co S coal slack
 C Gr coarse gravel
 CS coarse sand
 FS fine sand
 Gr gravel
 Lig Co lignite coal
 Lig Sl lignite slack
 Lm loam
 Rk rock
 Sd sand
 Sdy Cl sandy clay
 Sdy Cl Lm sandy clay loam
 Sdy Fl sandy fill
 Sdy Lm sandy loam
 Sc scoria
 Sh shale
 Si Cl silt clay
 Si Cl Lm silty clay loam
 Si Lm silty loam

NORTH DAKOTA DEPARTMENT OF TRANSPORTATION	
07-01-14	
REVISIONS	
DATE	CHANGE
12-18-20	Sheet Added - Continued from D-101-3



NDDOT UTILITY COMPANY AND ORGANIZATION ABBREVIATIONS

D-101-10

702COM 702 Communications
 ACCENT Accent Communications
 AGASSIZ WU Agassiz Water Users Incorporated
 AGC Associated General Contractors of America
 ALL PL Alliance Pipeline
 ALL SEAS WU All Seasons Water Users Association
 AMOCO PI Amoco Pipeline Company
 AMRDA HESS Amerada Hess Corporation
 AT&T AT&T Corporation
 B PAW Bear Paw Energy Incorporated
 BAKER ELEC Baker Electric
 BASIN ELEC Basin Electric Cooperative Incorporated
 BEK TEL Bek Communications Cooperative
 BELLE PL Belle Fourche Pipeline Company
 BLM Bureau of Land Management
 BNSF Burlington Northern Santa Fe Railway
 BOEING Boeing
 BRNS RWD Barnes Rural Water District
 BURK-DIV ELEC Burke-Divide Electric Cooperative
 BURL WU Burleigh Water Users
 CABLE ONE Cable One
 CABLE SERV Cable Services
 CAP ELEC Capital Electric Cooperative Incorporated
 CASS CO ELEC Cass County Electric Cooperative
 CASS RWU Cass Rural Water Users Incorporated
 CAV ELEC Cavalier Rural Electric Cooperative
 CBLCOM Cablecom Of Fargo
 CENEX PL Cenex Pipeline
 CENT PL WATER DIST Central Pipe Line Water District
 CENT PWR ELEC Central Power Electric Cooperative
 CENTURYLINK CenturyLink
 COE Corps of Engineers
 CONS TEL Consolidated Telephone
 CONT RES Continental Resource Inc
 CPR Canadian Pacific Railway
 D O E Department Of Energy
 DAK CARR Dakota Carrier Network
 DAK CENT TEL Dakota Central Telephone
 DAK RWD Dakota Rural Water District
 DGC Dakota Gasification Company
 DICKEY R NET Dickey Rural Networks
 DICKEY RWU Dickey Rural Water Users Association
 DICKEY TEL Dickey Telephone
 DNRR Dakota Northern Railroad
 DOME PL Dome Pipeline Company
 DVELEC Dakota Valley Electric Cooperative
 DVMW Dakota, Missouri Valley & Western
 ENBRDG Enbridge Pipelines Incorporated
 ENVENTIS Enventis Telephone
 FALK MNG Falkirk Mining Company
 FHWA Federal Highway Administration
 G FKS-TRL WD Grand Forks-traill Water District
 GETTY TRD & TRAN Getty Trading & Transportation
 GLDN W ELEC Golden West Electric Cooperative
 GRGS CO TEL Griggs County Telephone
 GTR RAMSEY WD Greater Ramsey Water District

GT PLNS NAT GAS Great Plains Natural Gas Company
 HALS TEL Halstad Telephone Company
 IDEA1 Idea1
 INT-COMM TEL Inter-Community Telephone Company
 KANEB PL Kaneb Pipeline Company
 KEM ELEC Kem Electric Cooperative Incorporated
 KOCH GATH SYS Koch Gathering Systems Incorporated
 LKHD PL Lakehead Pipeline Company
 LNGDN RWU Langdon Rural Water Users Incorporated
 LWR YELL R ELEC Lower Yellowstone Rural Electric
 MCKNZ CON McKenzie Consolidated Telcom
 MCKNZ ELEC McKenzie Electric Cooperative
 MCKNZ WRD McKenzie County Water Resource District
 MCLEOD McLeod USA
 MCLN ELEC McLean Electric Cooperative
 MCLN-SHRDN R WAT McLean-Sheridan Rural Water
 MDU Montana-dakota Utilities
 MIDCO MidContinent Communications
 MIDSTATE TEL Midstate Telephone Company
 MINOT CABLE Minot Cable Television
 MINOT TEL Minot Telephone Company
 MISS VALL COMM Missouri Valley Communications
 MISS W W S Missouri West Water System
 MNKOTA PWR Minnkota Power
 MOR-GRAN-SOU ELEC Mor-gran-sou Electric Cooperative
 MOUNT-WILLI ELEC Mountrail-williams Electric Cooperative
 MRE LBTY TEL Moore & Liberty Telephone
 MUNICIPAL City Water And Sewer
 MUNICIPAL City Of '.....'
 N CENT ELEC North Central Electric Cooperative
 N VALL W DIST North Valley Water District
 ND PKS & REC North Dakota Parks And Recreation
 ND TEL North Dakota Telephone Company
 NDDOT North Dakota Department of Transportation
 NDSU SOIL SCI DEPT NDSU Soil Science Department
 NEMONT TEL Nemont Telephone
 NODAK R ELEC Nodak Rural Electric Cooperative
 NOON FRMS TEL Noonan Farmers Telephone Company
 NPR Northern Plains Railroad
 NSP Northern States Power
 NTH PRAIR RW Northern Prairie Rural Water Association
 NTHN BRDR PL Northern Border Pipeline
 NTHN PLNS ELEC Northern Plains Electric Cooperative Incorporated
 NTHWSTRN REF Northwestern Refinery Company
 NW COMM Northwest Communication Cooperation
 NWRWD Northwest Rural Water District
 ONEOK Oneok gas
 OSHA Occupational Safety and Health Administration
 OTTR TL PWR Otter Tail Power Company
 P L E M Prairielands Energy Marketing
 POLAR COM Polar Communications
 PVT ELEC Private Electric
 QWEST Qwest Communications
 R&T W SUPPLY R & T Water Supply Association

RED RIV COMM Red River Rural Communications
 RESVTN TEL Reservation Telephone
 ROBRTS TEL Roberts Company Telephone
 R-RIDER ELEC Roughrider Electric Cooperative
 RRVW Red River Valley & Western Railroad
 S CENT REG WD South Central Regional Water District
 S E W U South East Water Users Incorporated
 SCOTT CABLE Scott Cable Television Dickinson
 SHERDN ELEC Sheridan Electric Cooperative
 SHEYN VLY ELEC Sheyenne Valley Electric Cooperative
 SKYTECH Skyland Technologies Incorporated
 SLOPE ELEC Slope Electric Cooperative Incorporated
 SOURIS RIV TELCOM Souris River Telecommunications
 ST WAT COMM State Water Commission
 STATE LN WATER State Line Water Cooperative
 STER ENG Sterling Energy
 STUT RWU Stutsman Rural Water Users
 SW PL PRJ Southwest Pipeline Project
 T M C Turtle Mountain Communications
 TCI TCI of North Dakota
 TESORO GHG PLNS PL Tesoro High Plains Pipeline
 TRI-CNTY WU Tri-County Water Users Incorporated
 TRL CO RWU Traill County Rural Water Users
 UNTD TEL United Telephone
 UPPR SOUR WUA Upper Souris Water Users Association
 US SPRINT U.S. Sprint
 USAF MSL CABLE U.S.A.F. Missile Cable
 USFWS US Fish and Wildlife Service
 USW COMM U.S. West Communications
 VRNDRY ELEC Verendrye Electric Cooperative
 W RIV TEL West River Telephone Incorporated
 WAPA Western Area Power Administration
 WEB W. E. B. Water Development Association
 WILLI RWA Williams Rural Water Association
 WILSTN BAS PL Williston Basin Interstate Pipeline Company
 WLSH RWD Walsh Water Rural Water District
 WOLVRTN TEL Wolverton Telephone
 XLENER Xcel Energy
 YSVR Yellowstone Valley Railroad

NORTH DAKOTA DEPARTMENT OF TRANSPORTATION	
07-01-14	
REVISIONS	
DATE	CHANGE
04-23-18	General Revisions
09-20-18	General Revisions
12-18-20	General Revisions



12 18 2020

LINE STYLES

D-101-20

Existing Topography

- Void — Void — Void — V Existing Ground Void
- + — + — Existing Cemetary Boundary
- - - - - Existing Box Culvert Bridge
- - - - - Existing Concrete Surface
- - - - - Existing Drainage Structure
- — — — — Existing Gravel Surface
- — — — — Existing Riprap
- — — — — Existing Dirt Surface
- — — — — Existing Asphalt Surface
- — — — — Existing Tie Point Line
- - - - - Existing Railroad Centerline
- . - . - . Existing Guardrail Cable
- • — • — • Existing Guardrail Metal
- . — . — . Existing Edge of Water
- - - - -x- - - - -x- Existing Fence
- | | | | | Existing Railroad
- Existing Field Line
- ~ ~ ~ ~ ~ Exst Flow
- ===== Existing Curb
- - - - - Existing Valley Gutter
- - - - - Existing Driveway Gutter
- ===== Existing Curb and Gutter
- ===== Existing Mountable Curb and Gutter

Proposed Topography

- - - - - Existing 3-Cable w Posts
- - - - - Site Boundary
- Existing Berm, Dike, Pit, or Earth Dam
- Existing Ditch Block
- ~ ~ ~ ~ ~ Existing Tree Boundary
- ===== Existing Brush or Shrub Boundary
- Existing Retaining Wall
- ===== Existing Planter or Wall
- ~ ~ ~ ~ ~ Existing W-Beam Guardrail with Posts
- — — — — Existing Railroad Switch
- ~ ~ ~ ~ ~ Gravel Pit - Borrow Area
- - - - - Existing Wet Area-Vegetation Break
- - - - - Existing High Tension Cable Guardrail
- • - • - • Existing High Tension Cable Guardrail with Posts
- — — — — 3-Cable w Posts
- ~ ~ ~ ~ ~ Flow
- x- - - -x- - - -x- Fence
- REMOVE — REMOVE — Remove Line
- ===== Wall
- ~ ~ ~ ~ ~ Retaining Wall (Plan View)
- ~ ~ ~ ~ ~ W-Beam w Posts
- — • — • High Tension Cable Guardrail with Posts

Existing Utilities

- — — — — E — Existing Electrical
- — — — — FO — Existing Fiber Optic Line
- — — — — FO — Existing TV Fiber Optic
- — — — — G — Existing Gas Pipe
- — — — — OH — Existing Overhead Utility Line
- — — — — P — Existing Power
- — — — — PL — Existing Fuel Pipeline
- — — — — PL — Existing Undefined Above Ground Pipe Line
- - - - - SAN - - - - - Existing Sanitary Sewer
- - - - - SAN FM - - - - - Existing Sanitary Force Main
- - - - - SD - - - - - Existing Storm Drain
- - - - - SD FM - - - - - Existing Storm Drain Force Main
- - - - - Existing Culvert
- — — — — T — Existing Telephone Line
- — — — — TV — Existing TV Line
- — — — — W — Existing Water or Steam Line
- ===== Existing Under Drain
- ===== Existing Slotted Drain
- — — — — Existing Conduit
- - - - - Existing Conductor
- — — — — Existing Down Guy Wire Down Guy
- — — — — Existing Underground Vault or Lift Station

Proposed Utilities

- ===== 24 Inch Pipe
- ===== Reinforced Concrete Pipe
- ===== Under Drain
- - - - - Edge Drain

Traffic Utilities

- - - - - Conductor
- - - - - Fiber Optic
- - - - - Existing Loop Detector
- — — — — Existing Double Micro Loop Detector
- — — — — Micro Loop Detector Double
- — — — — Existing Micro Loop Detector
- — — — — Micro Loop Detector
- ↓ — — — — Signal Head with Mast Arm
- ↓ — — — — Existing Signal Head with Mast Arm

Sign Structures

- — — — — Existing Overhead Sign Structure
- — — — — Existing Overhead Sign Structure Cantilever
- — — — — Overhead Sign Structure Cantilever

NORTH DAKOTA DEPARTMENT OF TRANSPORTATION	
07-01-14	
REVISIONS	
DATE	CHANGE
09-23-16	Added and Revised Items, Organized by Functional Groups
12-18-20	General Revisions

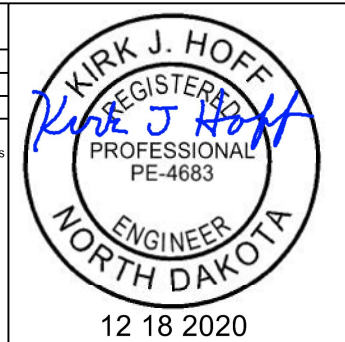

LINE STYLES

D-101-21

Right Of Way

- Easement
- Existing Easement
- Right of Way
- Existing Right of Way
- Existing Right of Way Railroad
- Existing Right of Way Not State Owned
- Existing Government Lot Line
- Existing Adjacent Block Lines
- Existing Adjacent Lot Lines
- Existing Adjacent Property Line
- Existing Adjacent Subdivision Lines
- Sight Distance Triangle Line
- Dimension Leader

Boundary Control

- ////// Existing City Corporate Limits or Reservation Boundary
- Existing State or International Line
- Existing Township
- Existing County
- Existing Section Line
- Existing Quarter Section Line
- Existing Sixteenth Section Line
- Existing Centerline
- Tangent Line

Cross Sections and Typical

- Existing Ground
- Existing Topsoil (Cross Section View)
- void - void - void - v Existing Ground Void (Not Surveyed)
- Existing Concrete
- Existing Aggregate (Cross Section View)
- Existing Curb and Gutter (Cross Section View)
- Existing Asphalt (Cross Section View)
- Existing Reinforcement Rebar

Geotechnical

- D ----- D ----- Geotextile Fabric Type D
- **Geo** ----- **Geo** ----- Geogrid
- R ----- R ----- Geotextile Fabric Type R
- R ----- R ----- Geotextile Fabric Type R1
- RR ----- RR ----- Geotextile Fabric Type RR
- S ----- S ----- Geotextile Fabric Type S

Countours

- Depression Contours
- Supplemental Contour

Profile

- Subgrade, Subcut or Ditch Grade
- Topsoil Profile

Striping

- Centerline Pavement Marking
- ===== Barrier with Centerline Pavement Marking
- ===== Barrier Pavement Marking
- - - - - Stripe 4 IN Dotted Extension White
- - - - - Stripe 8 IN Dotted Extension White
- - - - - Stripe 8 IN Lane Drop

Pavement Joints

- ===== Doweled Joint
- +++++ Tie Bar 30 Inch 4 Foot Center to Center
- +++++ Tie Bar 18 Inch 3 Foot Center to Center
- +++++ Tie Bar at Random Spacing

Bridge Details

- Small Hidden Object
- Large Hidden Object
- Phantom Object
- Existing Conditions Object
- Centerline Main
- Centerline Secondary
- Excavation Limits
- Proposed Ground
- Sheet Piling

Erosion Control

- Limits of Const Transition Line
- Bale Check
- Rock Check
- s ----- s ----- Floating Silt Curtain
- SF ----- SF ----- Silt Fence
- Excavation Limits
- Fiber Rolls







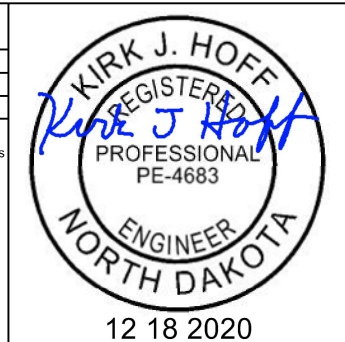



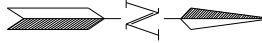





























Environmental

- Wetland Mitigation
- Existing Wetland Easement USFWS
- Existing Wetland Jurisdictional
- Existing Wetland
- Tree Row

NORTH DAKOTA DEPARTMENT OF TRANSPORTATION	
07-01-14	
REVISIONS	
DATE	CHANGE
09-23-16	Added and Revised Items, Organized by Functional Groups General Revisions
12-18-20	



SYMBOLS

















































































	North Arrow (Half Scale)		Existing Bush or Shrub		Continuous Split Barrel Sample
	Alignment Data Point		Existing Large Evergreen Tree		Flight Auger Sample
	Alignment Monument		Existing Small Evergreen Tree		Split Barrel Sample
	Spot Elevation		Existing Large Tree		Thinwall Tube Sample
	Existing Miscellaneous Spot		Existing Small Tree		Standard Penetration Test
	Existing Access Control Arrow		Existing Tree Trunk		Inclinometer Tube
	Existing Benchmark		Cairn or Stone Circle		Excavation Unit
	Reset USGS Marker		Existing Artifact		Existing Ground Water Well Bore Hole
	Iron Monument Found		Existing Satellite Dish		
	Iron Pin R/W Monument		Existing Weather Station		
	Property Corner		Existing Windmill or Tower		
	Iron Pin Reference Monument		Reinforced Pavement		
	Right of Way Marker (Exst, Ppsd, Reset)				
	Existing Federal Reference Corner				
	Existing Section Corner (Full, Quarter, Sixteenth, Meander)				
	Existing Section Corner (Full, Quarter, Sixteenth, Meander)				
	Existing Section Corner (Full, Quarter, Sixteenth, Meander)				
	Existing Section Corner (Full, Quarter, Sixteenth, Meander)				
	Existing Witness Corner				
	Existing Control Point (CP, GPS-RTK, TRI)				
	Existing Control Point (CP, GPS-RTK, TRI)				
	Existing Control Point (CP, GPS-RTK, TRI)				
	Existing Traverse PI Aerial Panel				
	Existing Reference Marker Point NGS				
	Existing EFB Misc				

NORTH DAKOTA DEPARTMENT OF TRANSPORTATION	
07-01-14	
REVISIONS	
DATE	CHANGE
12-18-20	General Revisions

 12 18 2020

SYMBOLS

D-101-32

 Existing Luminaire  Luminaire LED  Existing Light Standard Luminaire  Relocate Light Standard  Light Standard Light LED Luminaire  Light Standard 35 Watt High Pressure Sodium Vapor Luminaire  Light Standard 50 Watt High Pressure Sodium Vapor Luminaire  Light Standard 70 Watt High Pressure Sodium Vapor Luminaire  Light Standard 100 Watt High Pressure Sodium Vapor Luminaire  Light Standard 150 Watt High Pressure Sodium Vapor Luminaire  Light Standard 200 Watt High Pressure Sodium Vapor Luminaire  Light Standard 250 Watt High Pressure Sodium Vapor Luminaire  Light Standard 310 Watt High Pressure Sodium Vapor Luminaire  Light Standard 400 Watt High Pressure Sodium Vapor Luminaire  Light Standard 700 Watt High Pressure Sodium Vapor Luminaire  Light Standard 1000 Watt High Pressure Sodium Vapor Luminaire  Emergency Vehicle Detector  Video Detection Camera	  High Mast Light Standard 3 Luminaire (Exst, Ppsd)   High Mast Light Standard 4 Luminaire (Exst, Ppsd)   High Mast Light Standard 5 Luminaire (Exst, Ppsd)   High Mast Light Standard 6 Luminaire (Exst, Ppsd)   High Mast Light Standard 7 Luminaire (Exst, Ppsd)   High Mast Light Standard 8 Luminaire (Exst, Ppsd)   High Mast Light Standard 9 Luminaire (Exst, Ppsd)   High Mast Light Standard 10 Luminaire (Exst, Ppsd)   Overhead Sign Structure Load Center (Exst, Ppsd)   Traffic Signal Controller (Exst, Ppsd)   Pad Mounted Traffic Signal Controller (Exst, Ppsd)   Flashing Beacon (Exst, Ppsd)   Concrete Foundation (Exst, Ppsd)   Pipe Mounted Flasher (Exst, Ppsd)   Pad Mounted Feed Point (Exst, Ppsd)   Pipe Mounted Feed Point with Pad (Exst, Ppsd)   Pole Mounted Feed Point (Exst, Ppsd)   Junction Box (Exst, Ppsd)  Existing Pedestrian Head with Number  Existing Signal Head  Pole Mounted Head  Existing Lighting Standard Pole	 Existing Traffic Signal Standard    Pull Box (Exst-Ppsd-Undefined)   Intelligent Transportation Pull Box (Exst, Ppsd)   Transformer (Exst, Ppsd)    Power Pole (Exst-Ppsd-with Transformer)   Wood Pole (Exst, Ppsd)   Pedestrian Push Button Post (Exst, Ppsd)  Existing Pole  Existing Telephone Pole  Existing Post     Connection Conductor (Ground, Neutral, Phase 1, Phase 2)
---	---	--

NORTH DAKOTA DEPARTMENT OF TRANSPORTATION	
07-01-14	
REVISIONS	
DATE	CHANGE
12-18-20	General Revisions



12 18 2020

LANE MARKERS
(Spotting Tab for Seal Projects only)

Notes:

1. Install lane line markers as shown, prior to beginning the seal coat.
2. Attach cover to vertical part of marker so traffic does not cause it to detach, but it can be easily removed manually.
3. Remove protective covers immediately after seal coat is applied.
4. Remove markers after permanent pavement marking is installed.
5. Use marker body and cover manufactured from polyurethane material.
6. Marker types:
 Type Y - Yellow body and cover with yellow reflective tape on both sides.
 Type W - White body and cover with white reflective tape on one side.
7. Use retroreflective tape with a minimum reflectance of 1200 candle power per foot-candle per square foot, using a .1 degree observation angle and 0 degree entrance angle.
8. Use adhesive conforming to AASHTO M 237.

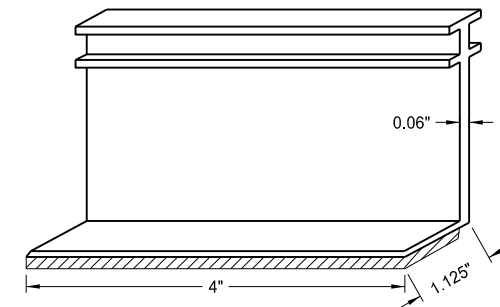
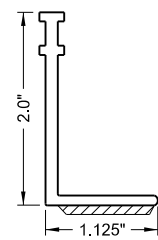

Marker Body

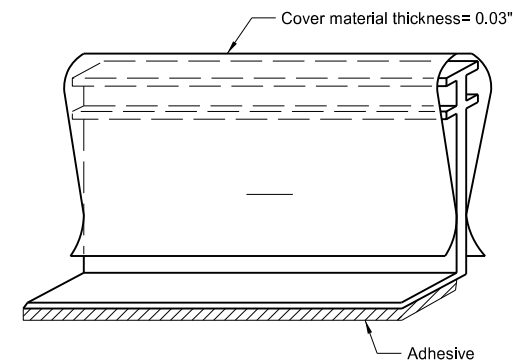
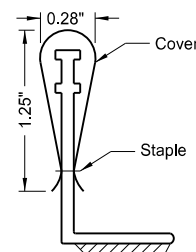

Marker Body with Protective Cover

NORTH DAKOTA DEPARTMENT OF TRANSPORTATION	
10-3-13	
REVISIONS	
DATE	CHANGE
9-27-17	Updated to active voice
10-03-19	New Design Engr PE Stamp

This document was originally issued and sealed by
 Kirk J Hoff,
 Registration Number
 PE- 4683,
 on 10/03/19 and the original document is stored at the
 North Dakota Department
 of Transportation

BREAKAWAY SYSTEMS FOR CONSTRUCTION ZONE SIGNS

Perforated Tube

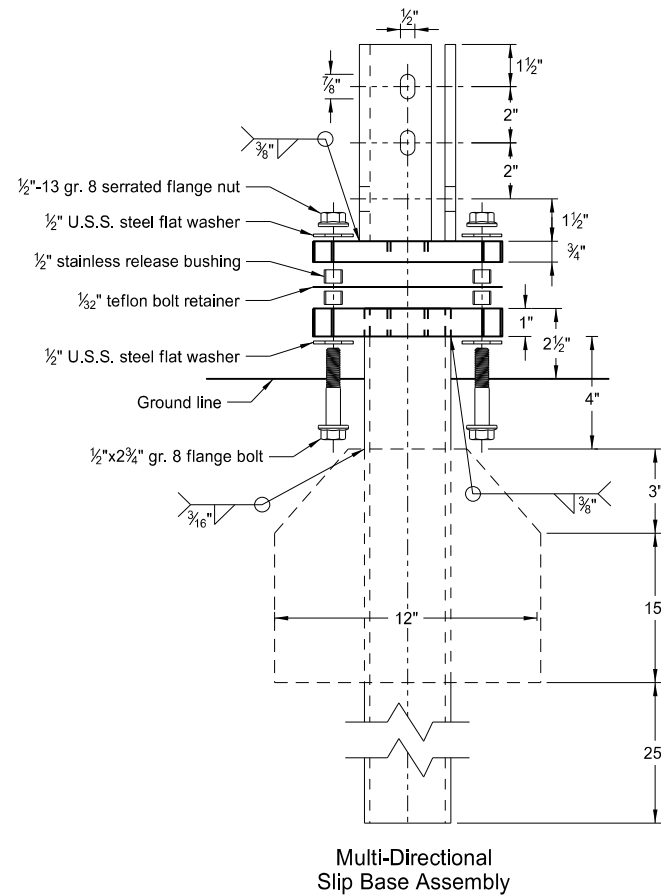

Multi-Directional Slip Base Assembly

Traffic Flow

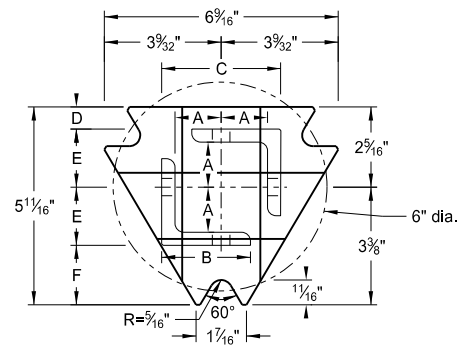

Top Post Receiver
Plate - ASTM A572 grade 50
Angle Receiver - 2 1/2" x 2 1/2" x 3/8" ASTM A36 structural angle

Traffic Flow

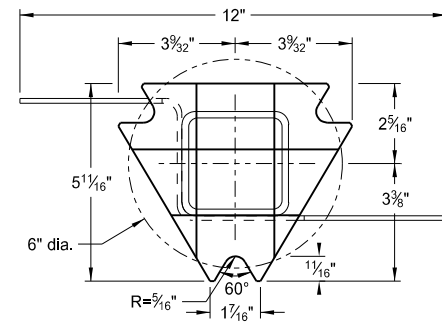

Bottom Soil Stub
Tube - 3"x3"x7 gauge ASTM A500 grade B tube
Stabilizing Wing - 7 gauge H.R.P.O. ASTM A1011
Plate - ASTM A572 grade 50

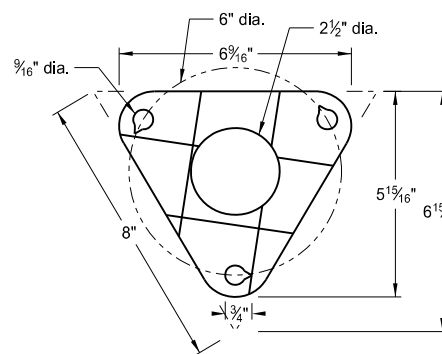

Bolt Retainer for Base Connection
Bolt Retainer- 1/2" Reprocessed Teflon

Notes:

1. Torque slip base bolts as specified by manufacturer.
2. Use anchor with 43.9 KSI yield strength and 59.3 KSI tensile strength.
3. Provide 4" vertical clearance for anchor or breakaway base. Measure the 4"x60" measurement above and below post location and back and ahead of post.
4. In concrete sidewalk, use same anchor without wings.
5. Provide more than 7' between the first and fourth posts of a four post sign.

Telescoping Perforated Tube

Number of Posts	Post Size in.	Wall Thickness Gauge	Sleeve Size in.	Wall Thickness Gauge	Slip Base	Anchor Size without Slip Base in.
1	2	12			No	2 1/4
1	2 1/4	12			No	2 1/2
1	2 1/2	12			(A)	3
1	2 1/2	10			Yes	
1	2 1/2	12	2	12	Yes	
1	2 1/2	12	2 1/4	12	Yes	
2	2	12			No	2 1/4
2	2 1/4	12			No	2 1/2
2	2 1/2	12			Yes	
2	2 1/2	12			Yes	
2	2 1/4	10	2	12	Yes	
2	2 1/2	12	2 1/4	12	Yes	
3 & 4	2 1/2	12			Yes	
3 & 4	2 1/2	10			Yes	
3 & 4	2 1/2	12	2 1/4	12	Yes	
3 & 4	2 1/4	12	2	12	Yes	
3 & 4	2 1/2	10	2 3/16	10	Yes	

Properties of Telescoping Perforated Tube

Tube Size in.	Wall Thickness in.	U.S. Standard Gauge	Weight per Foot lbs.	Moment of Inertia in. ⁴	Cross Sec. Area in. ²	Section Modulus in. ³
1 1/2 x 1 1/2	0.105	12	1.702	0.129	0.380	0.172
2 x 2	0.105	12	2.416	0.372	0.590	0.372
2 1/4 x 2 1/4	0.105	12	2.773	0.561	0.695	0.499
2 3/16 x 2 3/16	0.135	10	3.432	0.605	0.841	0.590
2 1/2 x 2 1/2	0.105	12	3.141	0.804	0.803	0.643
2 1/2 x 2 1/2	0.135	10	4.006	0.979	1.010	0.785

Top Post Receiver Data Table

Square Post Sizes (B)	A	B	C	D	E	F
2 3/16" x 10 ga.	1 5/16"	2 1/2"	3 1/2"	2 5/32"	1 33/64"	1 7/8"
2 1/2" x 10 ga.	1 3/32"	2 1/2"	3 5/16"	5/8"	1 21/32"	1 3/4"

(A) Use breakaway base when support is placed in weak soils. Engineer determines if soils are weak.

(B) For additional wind load, insert the 2 3/16" x 10 ga. into 2 1/2" x 10 ga.

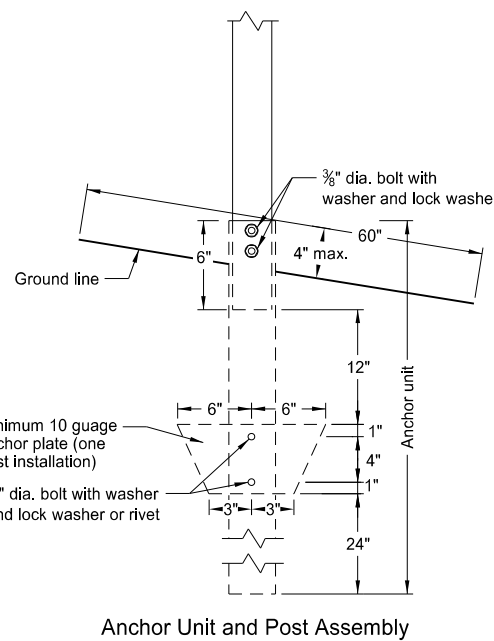

Anchor Unit and Post Assembly

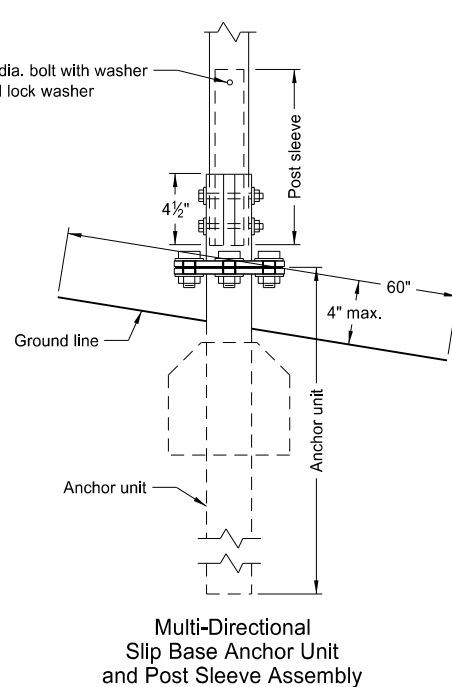

Multi-Directional Slip Base Anchor Unit and Post Sleeve Assembly

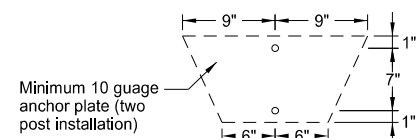

Minimum 10 gauge anchor plate (two post installation)

NORTH DAKOTA DEPARTMENT OF TRANSPORTATION	
2-28-14	
REVISIONS	
DATE	CHANGE
9-27-17	Updated to active voice
10-03-19	New Design Engr PE Stamp

This document was originally issued and sealed by
Kirk J Hoff,
Registration Number
PE-4683,
on 10/03/19 and the original document is stored at the North Dakota Department of Transportation

U-Channel Post

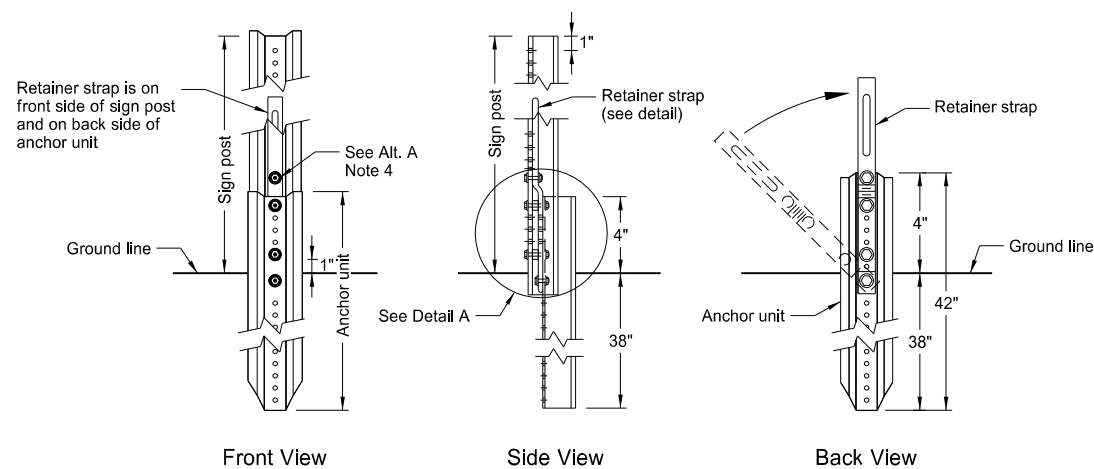
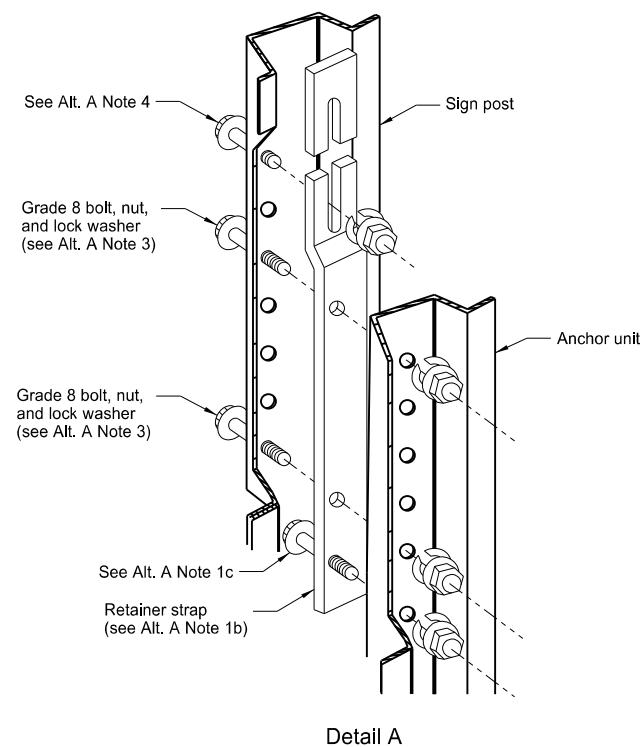

Breakaway U-Channel Detail Alternate A
Install a maximum of 2 posts within 7'.

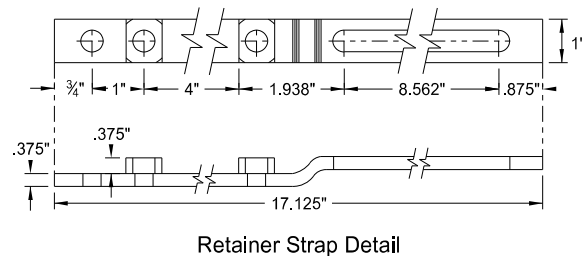

Retainer Strap Detail

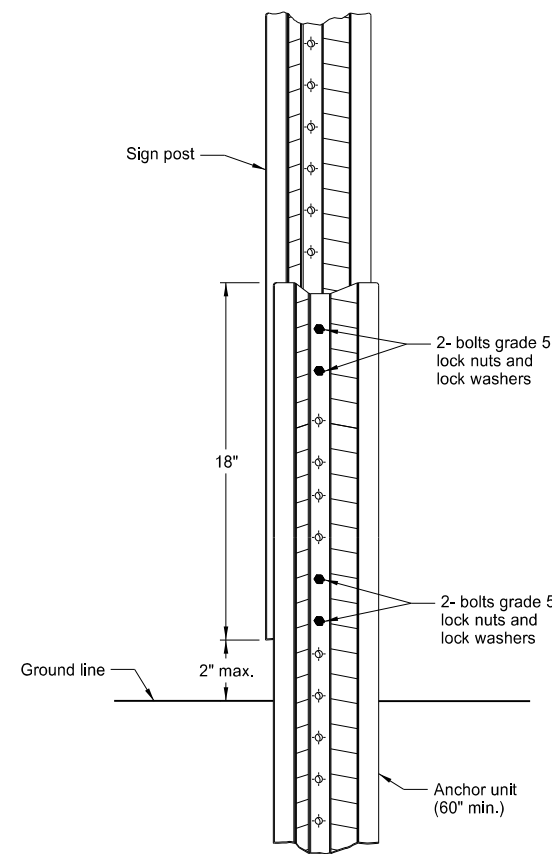

Breakaway U-Channel Splice Detail Alternate B
(2.5 and 3 lb/ft)
Install a maximum of 3 posts within 7'.

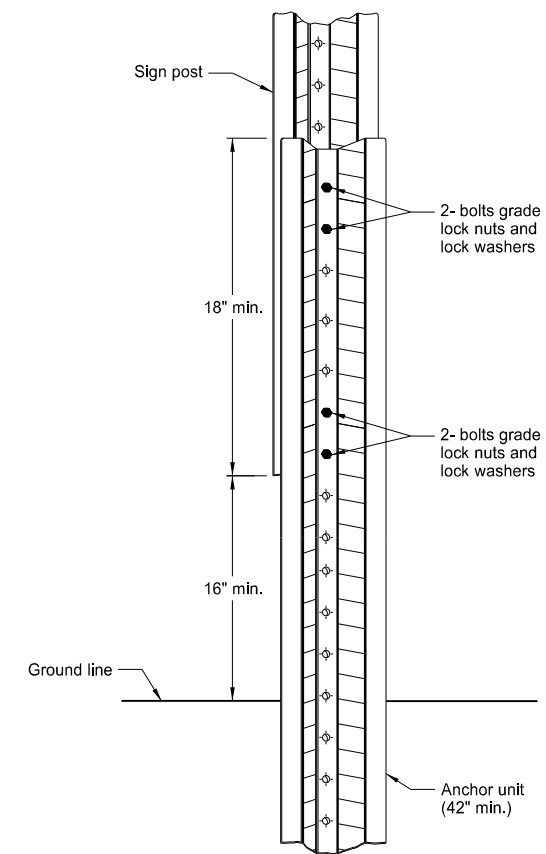

Breakaway U-Channel Splice Detail Alternate C
(2.5 and 3 lb/ft)
Install a maximum of 3 posts within 7'.

Alternate A Steps of Installation:

1. a) Drive anchor unit to within 12" of ground level.
b) Establish proper assembly by lining up bottom hole of retainer strap with 6th hole from the top of the anchor unit.
c) Assemble strap to back of anchor unit using 5/16"x2" bolt, lock washer and nut.
d) Rotate strap 90° to left.
2. a) Drive anchor unit to 4" above ground.
b) Rotate strap to vertical position.
3. a) Place 5/16"x2" bolt, lock washer and nut in bottom of sign post to facilitate alignment of sign post with proper hole in anchor unit.
b) Alternately tighten two connector bolts.
4. Complete assembly by tightening 5/16"x2" bolt (this fastens sign post to retainer strap).
5. Properly nest base post, strap, and sign post. Proper nesting occurs when all flat surfaces of the base post, strap, and sign post at the bolts have full contact across the entire width.

NORTH DAKOTA DEPARTMENT OF TRANSPORTATION	
2-28-14	
REVISIONS	
DATE	CHANGE
9-27-17 10-03-19	Updated to active voice New Design Engr PE Stamp

This document was originally issued and sealed by
Kirk J Hoff,
Registration Number
PE- 4683,
on 10/03/19 and the original document is stored at the North Dakota Department of Transportation

CONSTRUCTION SIGN DETAILS
 TERMINAL AND GUIDE SIGNS

D-704-9

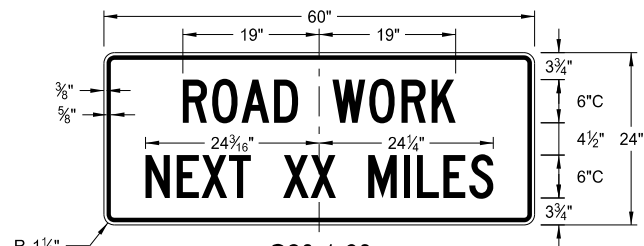

G20-1-60
 Legend: black (non-refl)
 Background: orange

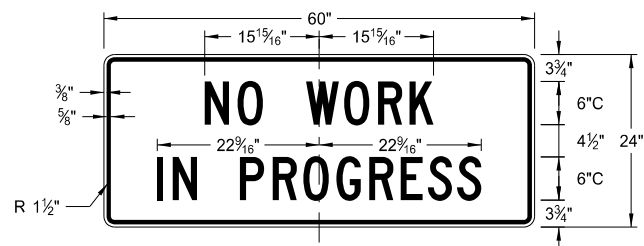

G20-1b-60
 Legend: black (non-refl)
 Background: orange

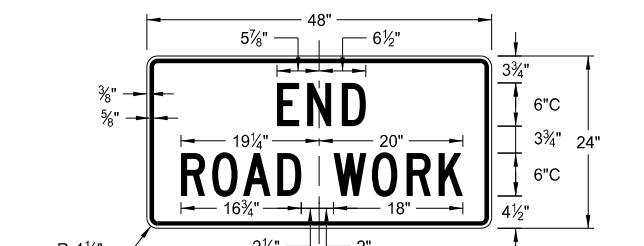

G20-2-48
 Legend: black (non-refl)
 Background: orange



G20-4b-36
 Legend: black (non-refl)
 Background: orange

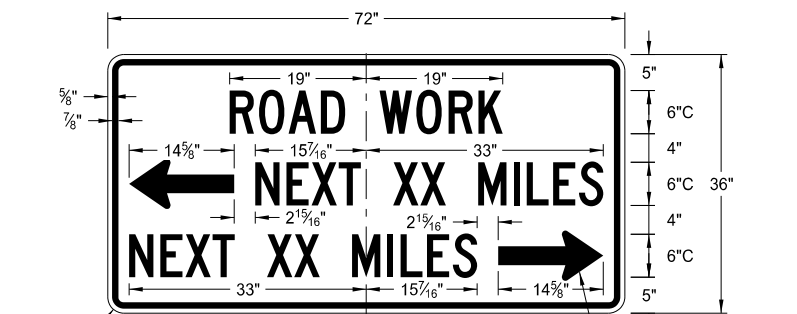

G20-50a-72
 Legend: black (non-refl)
 Background: orange

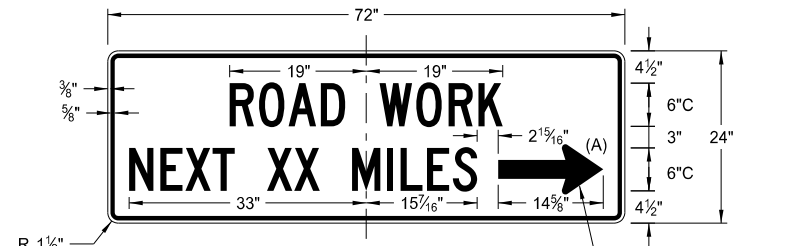

G20-52a-72
 Legend: black (non-refl)
 Background: orange

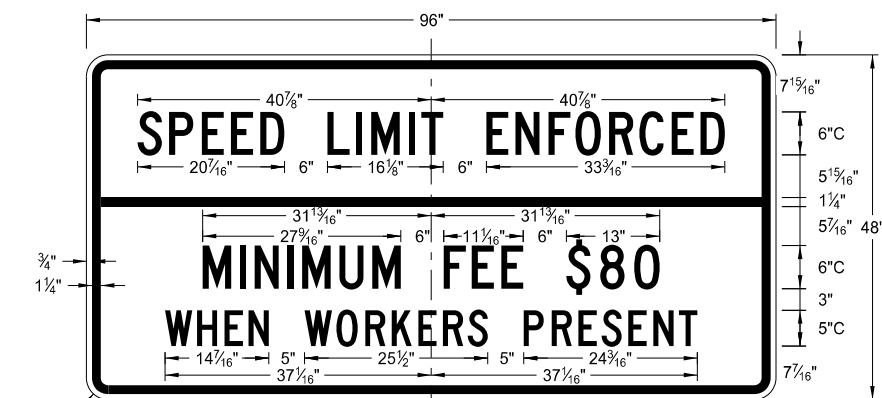

G20-55-96
 Legend: black (non-refl)
 Background: orange

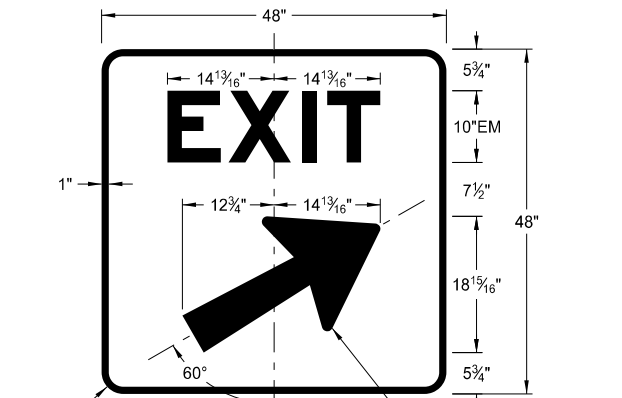

E5-1(L or R)-48
 Legend: white
 Background: green (orange optional)

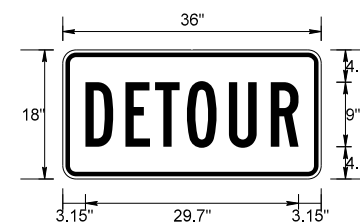

M4-8-36
 Legend: black (non-refl)
 Background: orange

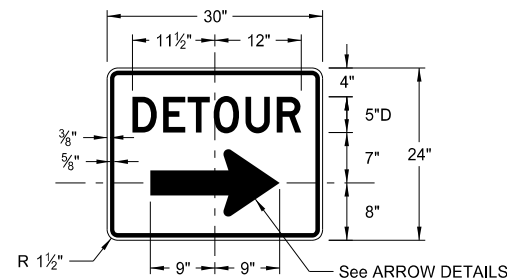

M4-9(L or R)-30 &
 M4-9-30
 Legend: black (non-refl)
 Background: orange

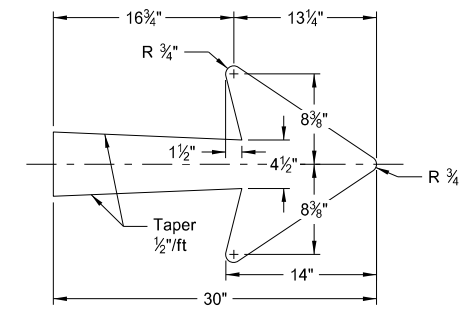

E5-1-48

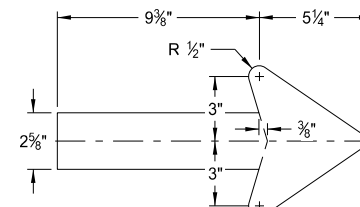

G20-50a-72
 G20-52a-72

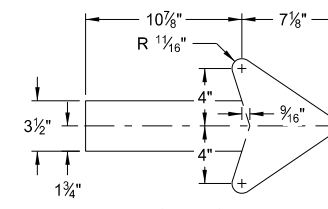

M4-9(L or R)-30
 Right or Left

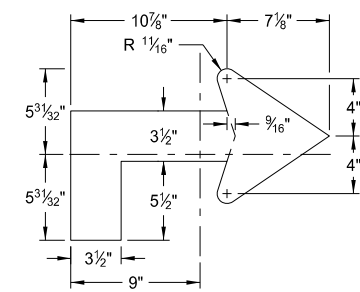

M4-9(L or R)-30
 Advanced Right or Left

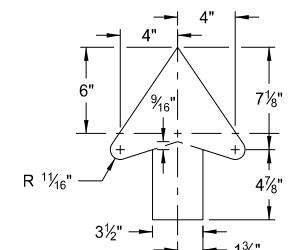

M4-9-30
 Straight

ARROW DETAILS

NOTES:

(A) Arrow may be right or left of the legend to indicate construction to the right or left.

NORTH DAKOTA DEPARTMENT OF TRANSPORTATION	
8-13-13	
REVISIONS	
DATE	CHANGE
8-17-17 10-03-19	Added sign & background color New Design Engineer PE Stamp

This document was originally issued and sealed by
 Kirk J Hoff,
 Registration Number
 PE- 4683,
 on 10/03/19 and the original document is stored at the
 North Dakota Department
 of Transportation

CONSTRUCTION SIGN DETAILS
REGULATORY SIGNS

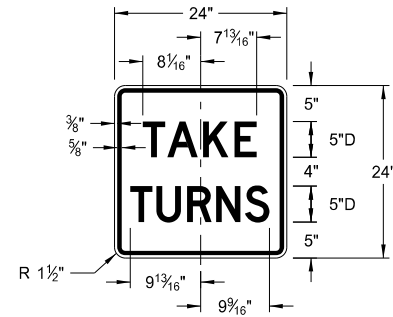

R1-50P-24
Legend: black (non-refl)
Background: white

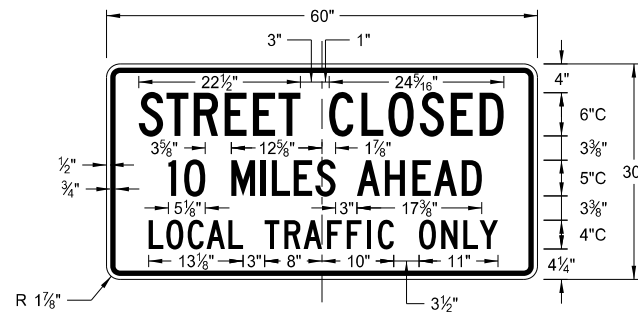

R11-3c-60
Legend: black (non-refl)
Background: white

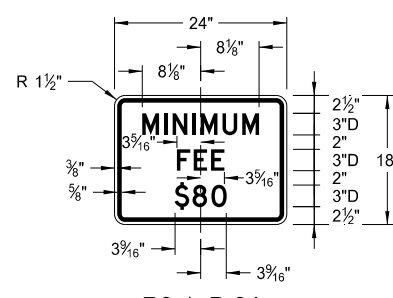

R2-1aP-24
Legend: black (non-refl)
Background: white

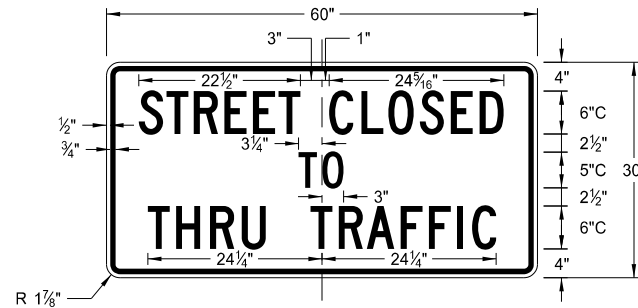

R11-4a-60
Legend: black (non-refl)
Background: white

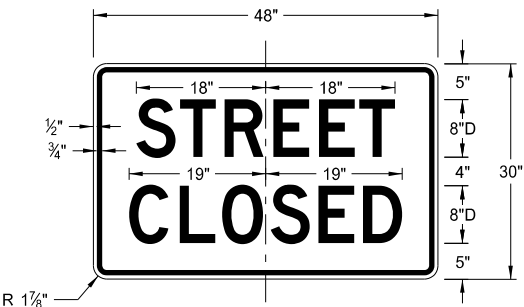

R11-2a-48
Legend: black (non-refl)
Background: white

NORTH DAKOTA DEPARTMENT OF TRANSPORTATION	
8-13-13	
REVISIONS	
DATE	CHANGE
8-17-17	Revised sign number
10-03-19	New Design Engineer PE Stamp

This document was originally issued and sealed by
Kirk J Hoff,
Registration Number
PE- 4683,
on 10/03/19 and the original document is stored at the
North Dakota Department
of Transportation

CONSTRUCTION SIGN DETAILS
WARNING SIGNS

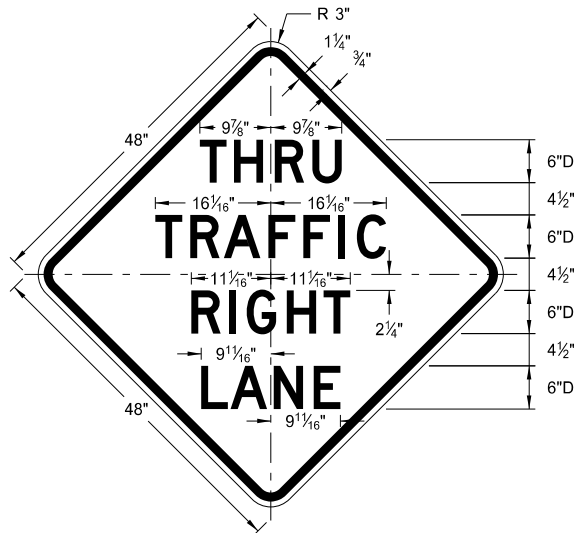

W5-8-48

Legend: black (non-refl)
Background: orange

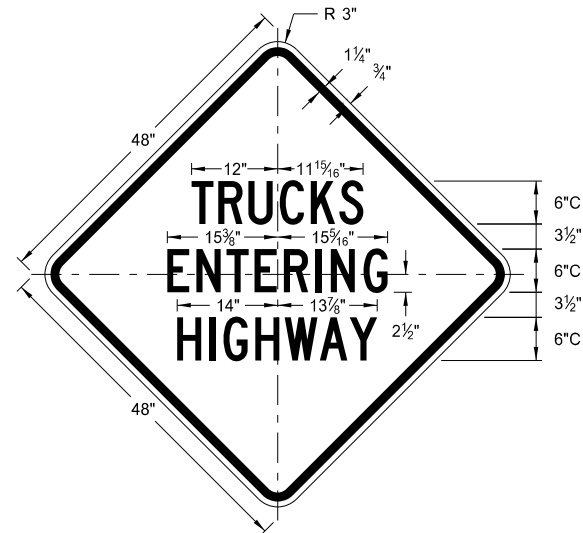

W8-53-48

Legend: black (non-refl)
Background: orange

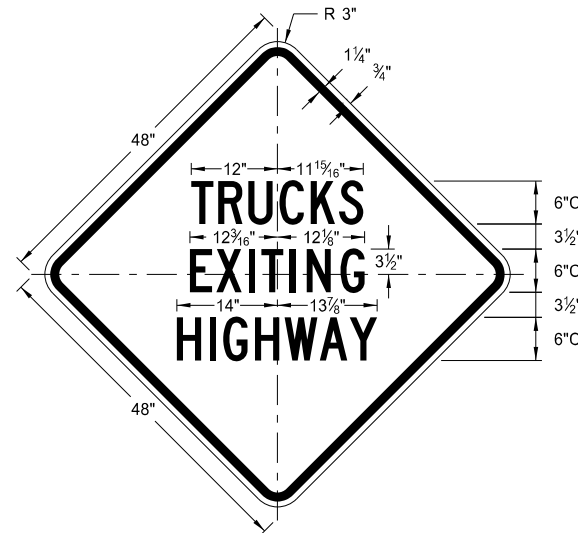

W8-56-48

Legend: black (non-refl)
Background: orange

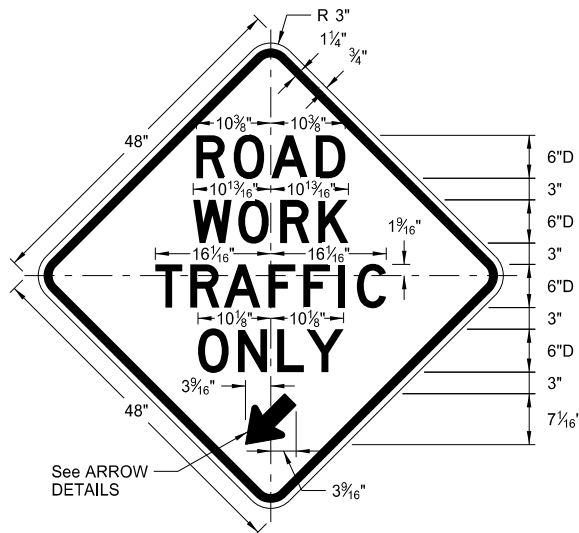

W5-9-48

Legend: black (non-refl)
Background: orange

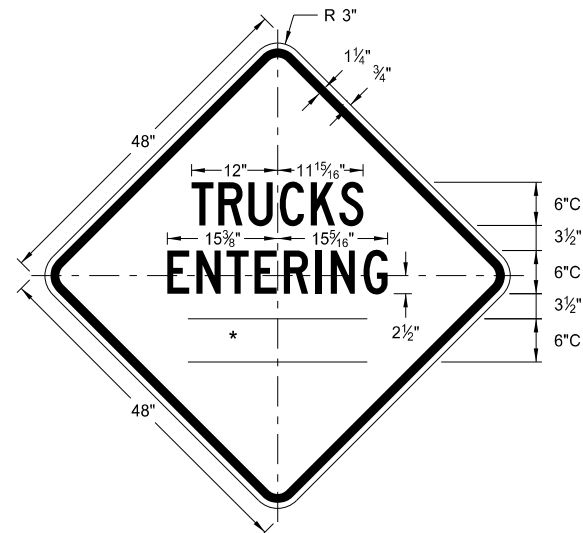

W8-54-48

Legend: black (non-refl)
Background: orange

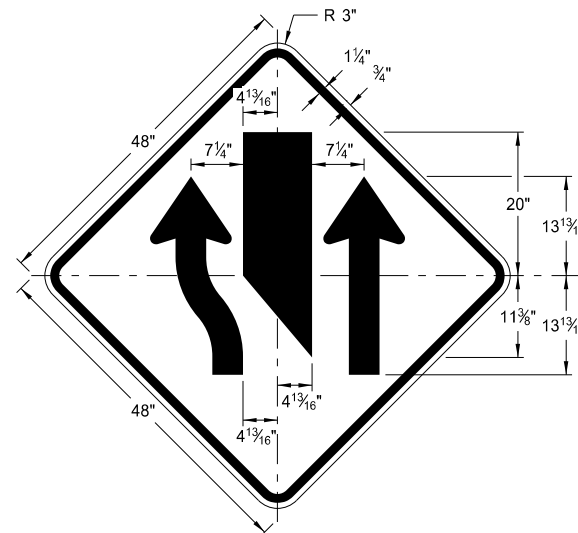

W9-3a-48

Legend: black (non-refl)
Background: orange

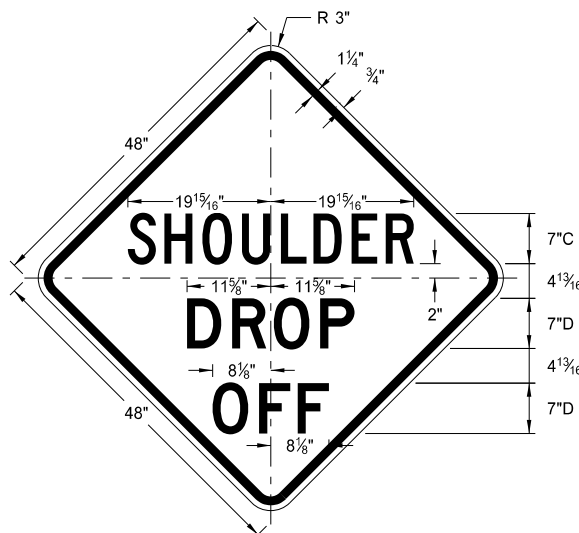

W8-9a-48

Legend: black (non-refl)
Background: orange

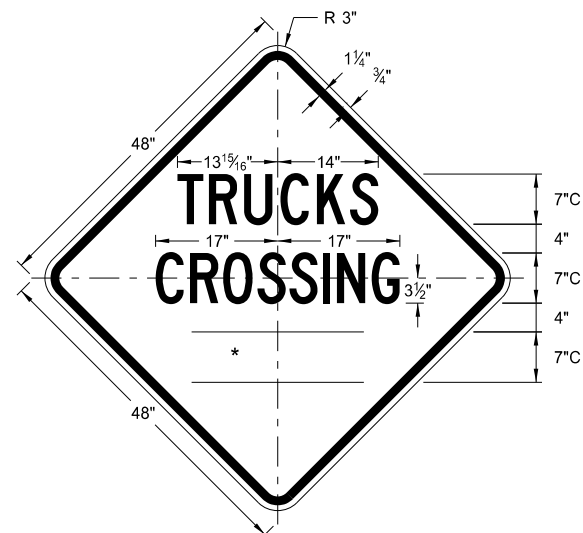

W8-55-48

Legend: black (non-refl)
Background: orange

WORD	LETTER SPACING
AHEAD	Standard
200 FT	Standard
350 FT	Standard
500 FT	Standard
1000 FT	Reduce 40%
1500 FT	Reduce 40%
½ MILE	Reduce 50%
1 MILE	Standard

* DISTANCE MESSAGES

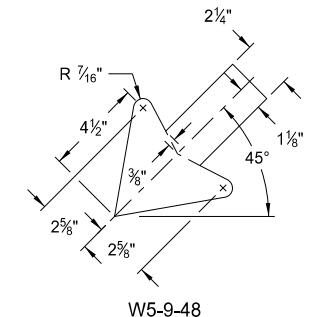

W5-9-48

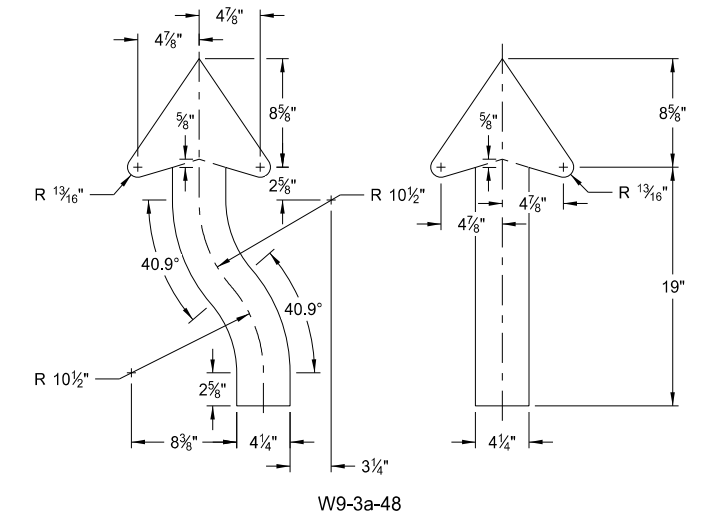

W9-3a-48

ARROW DETAILS

NORTH DAKOTA DEPARTMENT OF TRANSPORTATION	
8-13-13	
REVISIONS	
DATE	CHANGE
8-17-17	Updated sign number
5-31-18	Revised sign and arrow details
10-03-19	New Design Engineer PE Stamp

This document was originally issued and sealed by
Kirk J Hoff,
Registration Number
PE- 4683,
on 10/03/19 and the original document is stored at the North Dakota Department of Transportation

CONSTRUCTION SIGN DETAILS
WARNING SIGNS

WORD	LETTER SPACING
AHEAD	Standard
200 FT	Standard
350 FT	Standard
500 FT	Standard
1000 FT	Reduce 40%
1500 FT	Reduce 40%
½ MILE	Reduce 50%
1 MILE	Standard

* DISTANCE MESSAGES

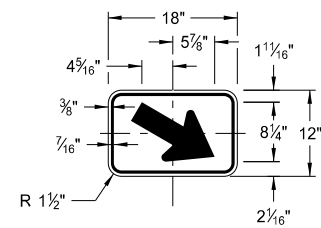

W16-7aP-18

Legend: black (non-refl)
Background: orange

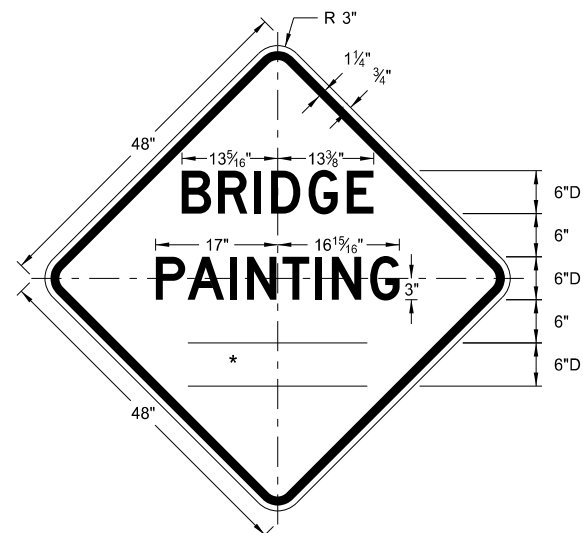

W21-50-48

Legend: black (non-refl)
Background: orange

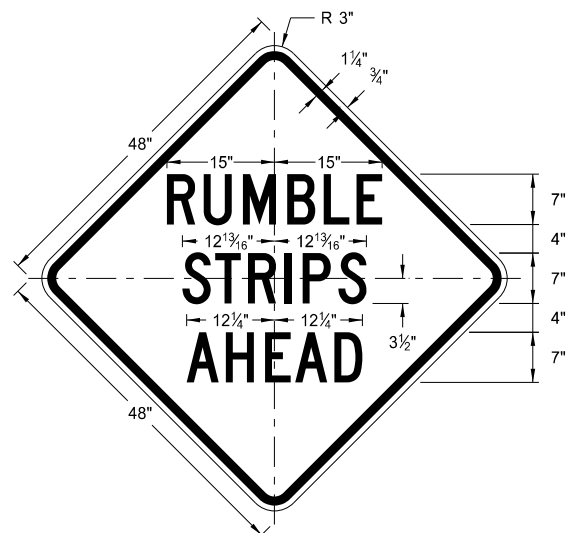

W21-53-48

Legend: black (non-refl)
Background: orange

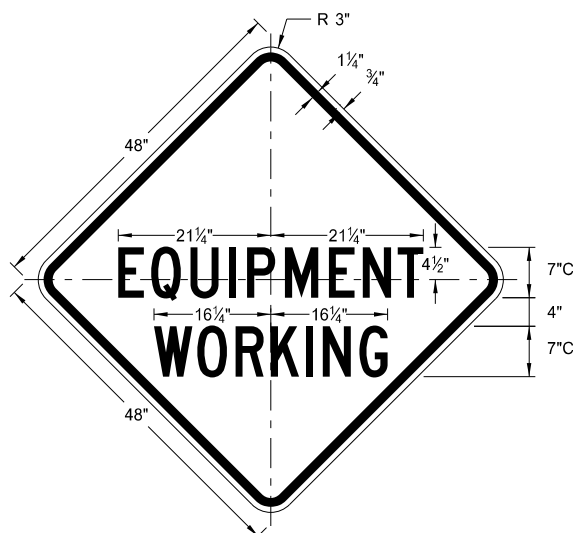

W20-51-48

Legend: black (non-refl)
Background: orange

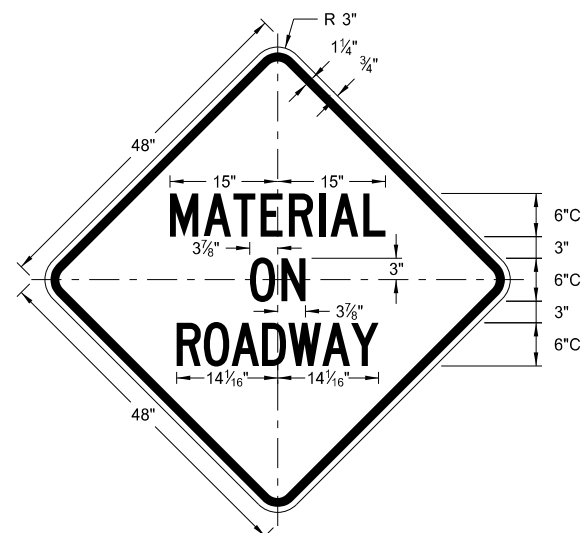

W21-51-48

Legend: black (non-refl)
Background: orange

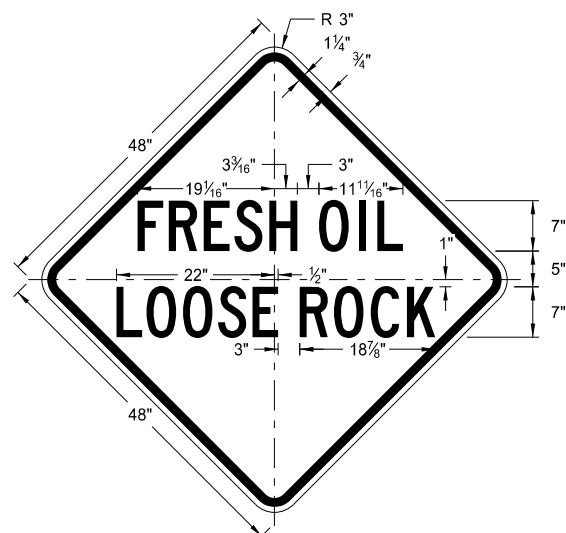

W22-8-48

Legend: black (non-refl)
Background: orange

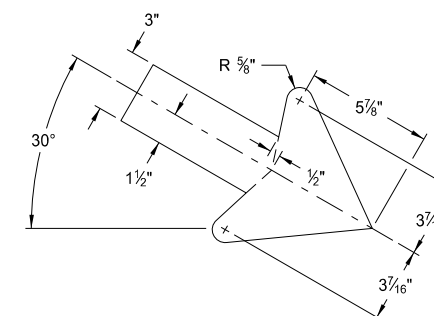

W16-7aP-18

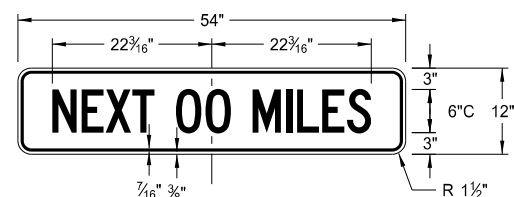

W20-52P-54

Legend: black (non-refl)
Background: orange

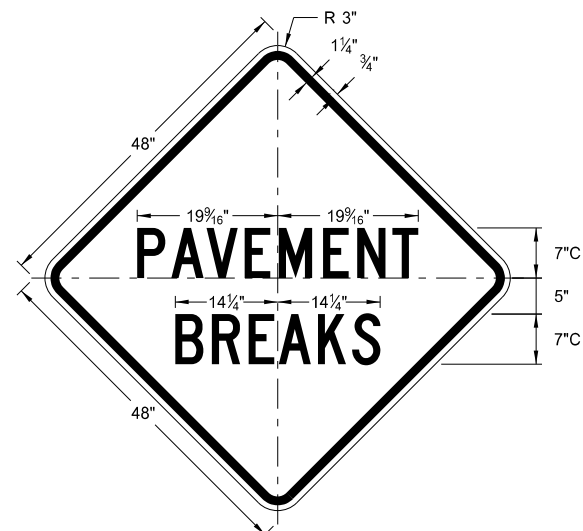

W21-52-48

Legend: black (non-refl)
Background: orange

NORTH DAKOTA DEPARTMENT OF TRANSPORTATION	
5-31-18	
REVISIONS	
DATE	CHANGE
11-01-19	Added details for sign W16-7aP-18.

This document was originally issued and sealed by
Kirk J Hoff,
Registration Number
PE- 4683,
on 11/1/19 and the original document is stored at the North Dakota Department of Transportation

BARRICADE AND CHANNELIZING DEVICE DETAILS

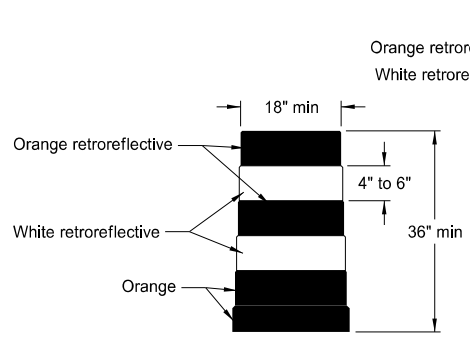

DELINEATOR DRUM

Provide horizontal, circumferential, alternating orange and white retroreflective stripes 4" to 6" wide for drum markings. Use a minimum of two orange and two white stripes with the top stripe being orange for each drum. Do not exceed 3" nonretroreflectorized spaces between the horizontal orange and white stripes. Avoid placement of stripes on drum ribs or indentations. Use closed top drums that will not allow collection of debris. Do not place ballast on the top of drum.

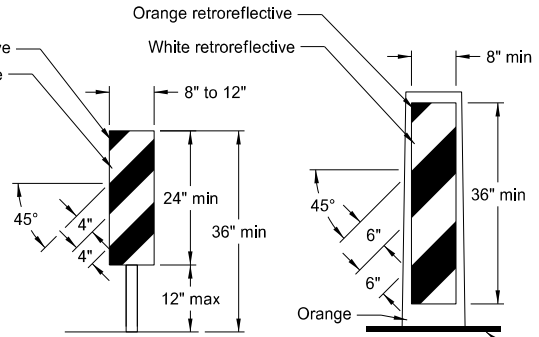

BACK TO BACK VERTICAL PANEL STACKABLE

Provide alternating orange and white retroreflective stripes, sloping downward in direction vehicular traffic is to pass. Place retroreflective sheeting on both sides of panel with a minimum of 270 square inches of retroreflective area facing vehicular traffic. Where the height of the retroreflective material on the vertical panel is 36 inches or more, use a stripe width of 6 inches.

Molded rubber base (min weight 30 lbs)

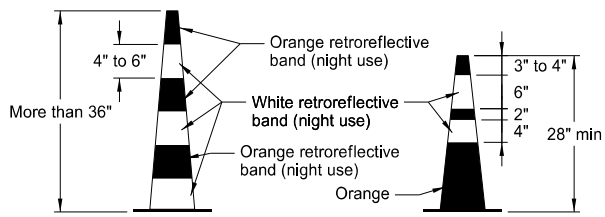

TRAFFIC CONE

Provide retroreflectorization of cones more than 36" in height by alternating orange and white retroreflective stripes. Use a minimum of two orange and two white stripes for each cone with the top stripe being orange. Use maximum 3" nonretroreflectorized space between the orange and white stripes.

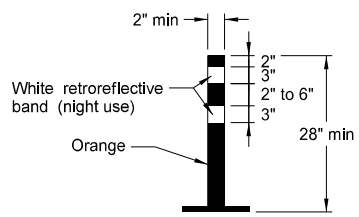

TUBULAR MARKER

Provide retroreflectorization of tubular markers more than 42" in height by alternating four 4" to 6" wide orange and white stripes with the top stripe being orange.

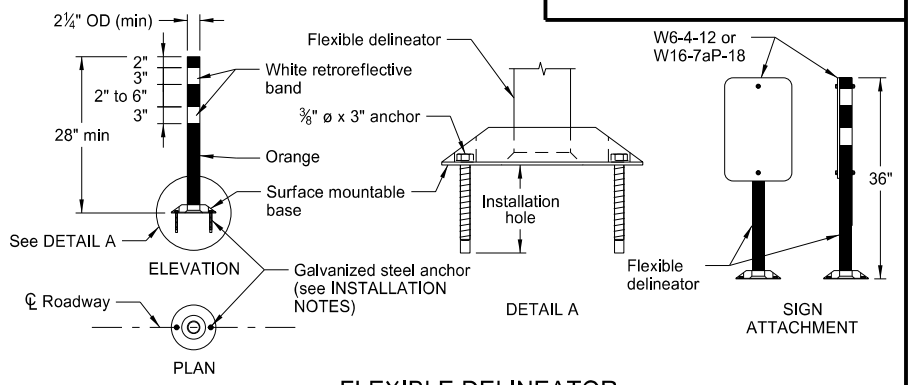

FLEXIBLE DELINEATOR

INSTALLATION NOTES:

1. Drill installation holes to diameter and depth required by manufacturer's specifications.
2. For removal, remove anchors and fill installation hole with an epoxy designed to bond to pavement surface.
3. In lieu of bolted down base, use an 8" x 8" butyl pad or hot melt butyl. Remove butyl as close as possible to pavement surface.

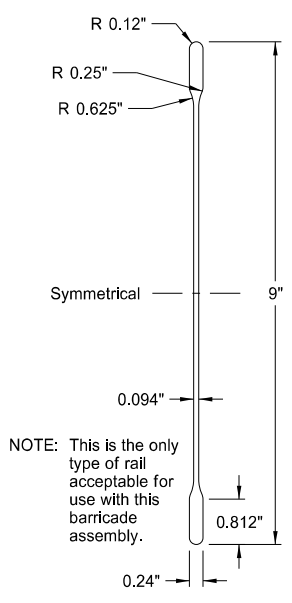

BARRICADE BLADE DETAIL

NOTE: This is the only type of rail acceptable for use with this barricade assembly.

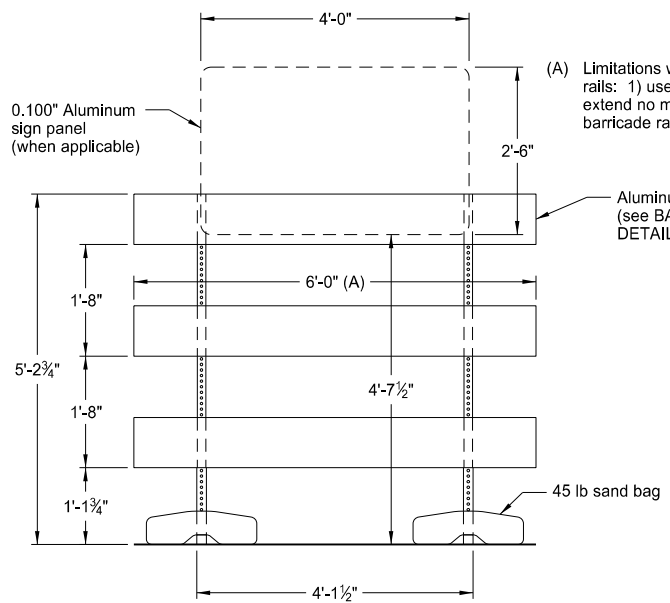

ELEVATION VIEW BARRICADE ASSEMBLY DETAIL (Aluminum Barricade Rails)

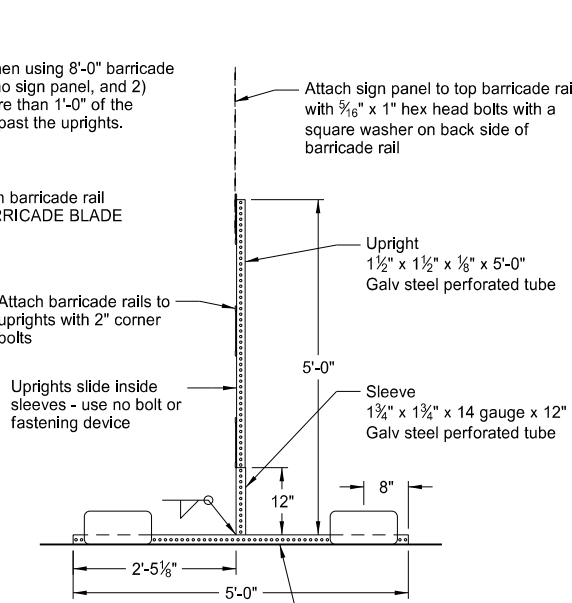

SIDE VIEW

(A) Limitations when using 8'-0" barricade rails: 1) use no sign panel, and 2) extend no more than 1'-0" of the barricade rail past the uprights.

Attach sign panel to top barricade rail with 3/16" x 1" hex head bolts with a square washer on back side of barricade rail

Attach barricade rails to uprights with 2" corner bolts

Uprights slide inside sleeves - use no bolt or fastening device

Upright 1 1/2" x 1 1/2" x 1/8" x 5'-0" Galv steel perforated tube

Sleeve 1 3/4" x 1 3/4" x 14 gauge x 12" Galv steel perforated tube

Skid 1 3/4" x 1 3/4" x 14 gauge x 5'-0" Galv steel perforated tube

Aluminum barricade rail (see BARRICADE BLADE DETAIL)

0.100" Aluminum sign panel (when applicable)

45 lb sand bag

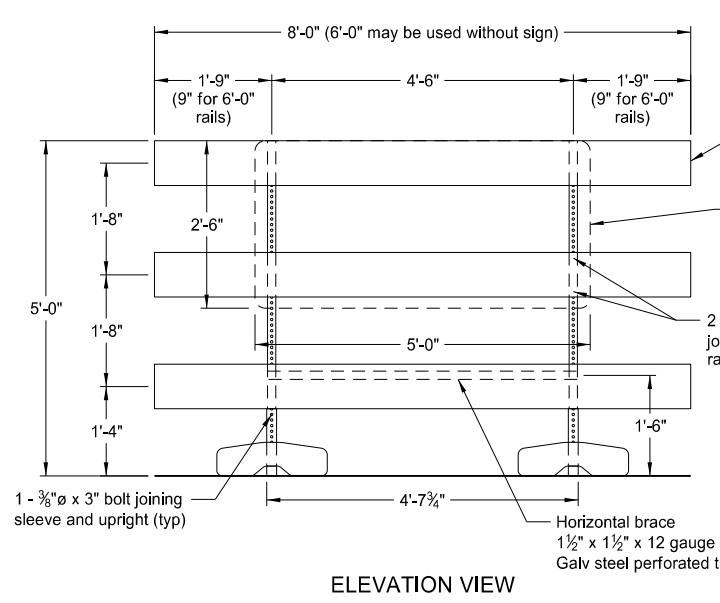

ELEVATION VIEW

BARRICADE ASSEMBLY DETAIL (Wood or Plastic Rails)

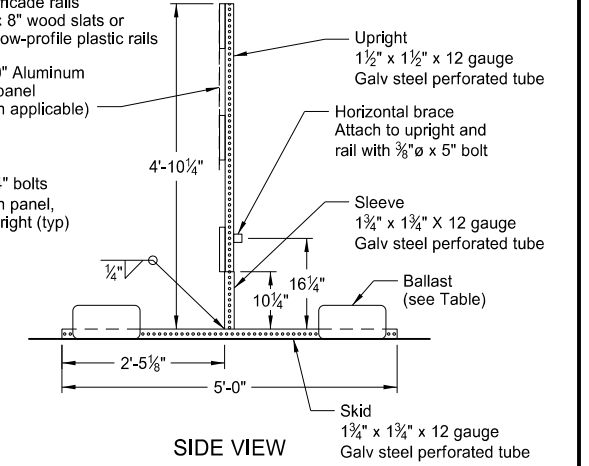

SIDE VIEW

Barricade rails 1" x 8" wood slats or hollow-profile plastic rails

0.080" Aluminum sign panel (when applicable)

Upright 1 1/2" x 1 1/2" x 12 gauge Galv steel perforated tube

Horizontal brace Attach to upright and rail with 3/8" x 5" bolt

Sleeve 1 3/4" x 1 3/4" X 12 gauge Galv steel perforated tube

Ballast (see Table)

Skid 1 3/4" x 1 3/4" x 12 gauge Galv steel perforated tube

2 - 3/8" x 4" bolts joining sign panel, rail and upright (typ)

Horizontal brace 1 1/2" x 1 1/2" x 12 gauge Galv steel perforated tube

1 - 3/8" x 3" bolt joining sleeve and upright (typ)

NOTE: For barricade markings use alternating orange and white retroreflective stripes, sloping downward in the direction traffic is to pass. Place retroreflective sheeting on both sides of the rails with a minimum of 270 square inches of visible retroreflective area facing vehicular traffic. When the barricade length is less than 36", use a rail stripe width of 4".

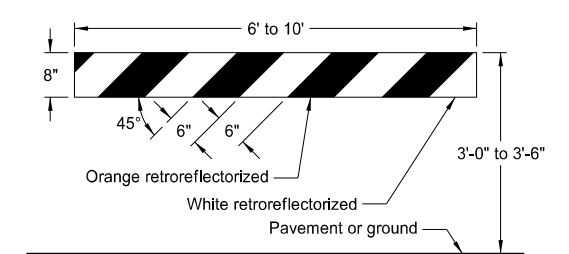

TYPE I BARRICADE

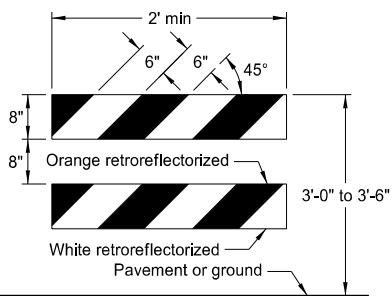

TYPE II BARRICADE

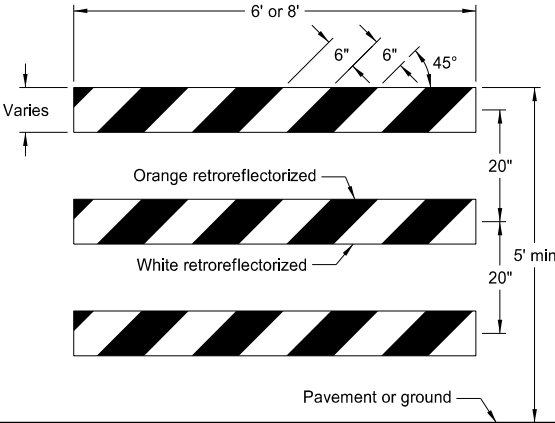

TYPE III BARRICADE

BARRICADE RAIL DETAILS

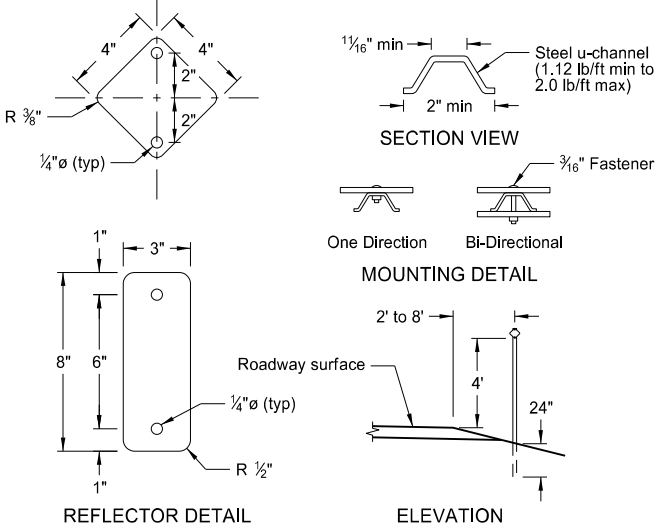

REFLECTOR DETAIL

ELEVATION

DELINEATORS

MINIMUM BALLAST (For each side of barricade support)

Without Sign	4 - 25 lb sandbags
With Sign	6 - 25 lb sandbags

Note: Number of sandbags based on a wind speed of 55 MPH. Sandbags assumed to be placed at or near the ends of the skids.

NORTH DAKOTA DEPARTMENT OF TRANSPORTATION	
10-3-13	
REVISIONS	
DATE	CHANGE
9-27-17 11-01-19	Updated to active voice Revised details for Flexible Delineator

This document was originally issued and sealed by Kirk J Hoff, Registration Number PE-4683, on 11/1/19 and the original document is stored at the North Dakota Department of Transportation

CONSTRUCTION SIGN PUNCHING AND MOUNTING DETAILS

Note: In curb sections, place signs a minimum horizontal distance of 2' from face of the curb to near edge of the sign.

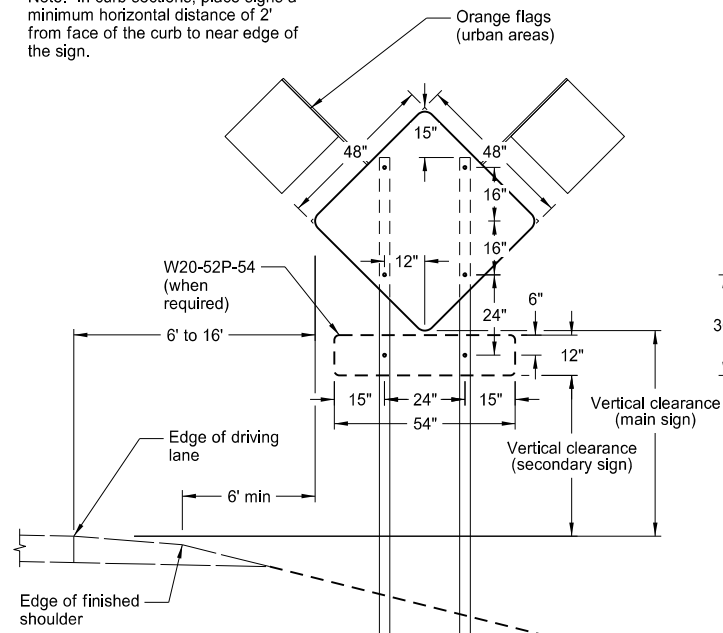

TYPICAL SECTION
(48" x 48" diamond warning sign shown)

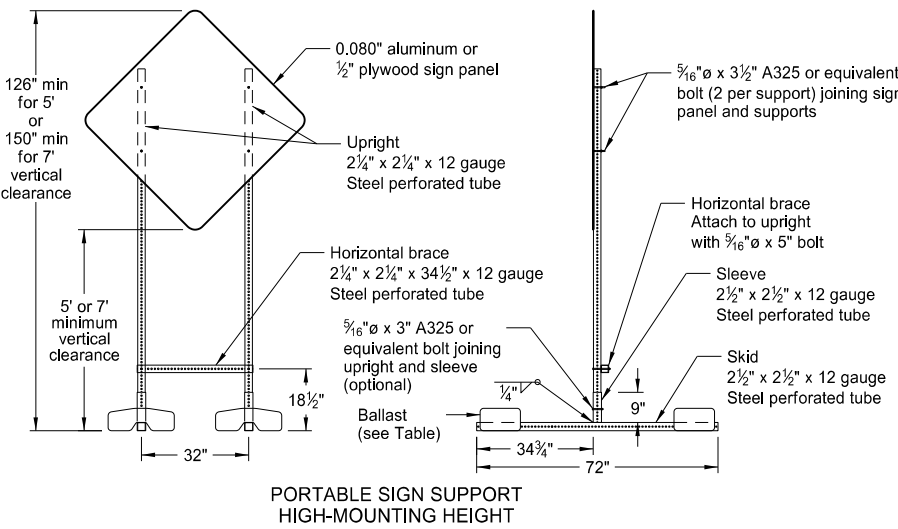
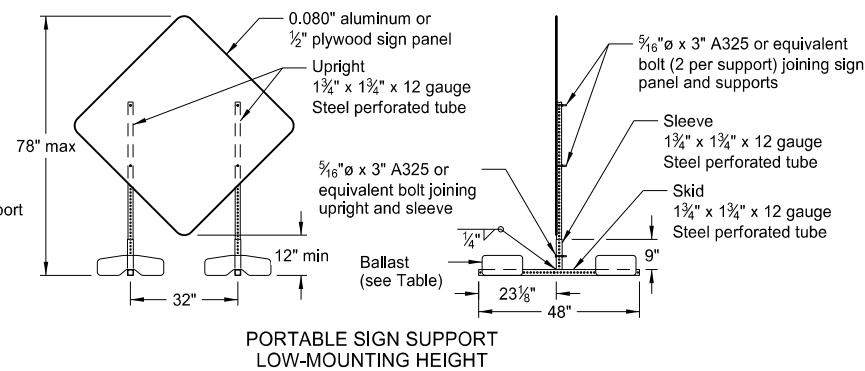
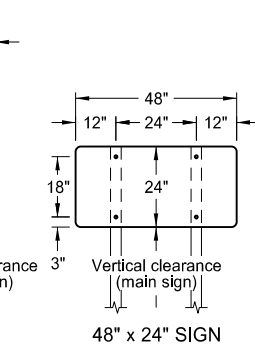
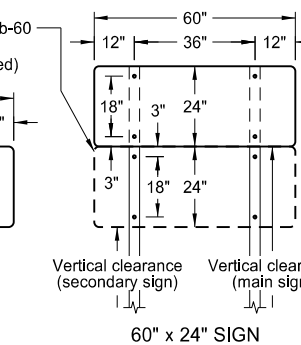
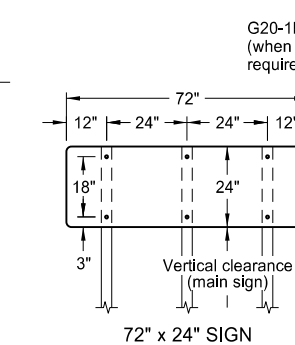
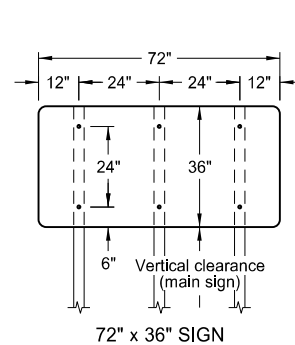
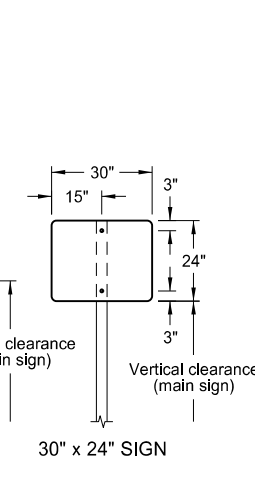
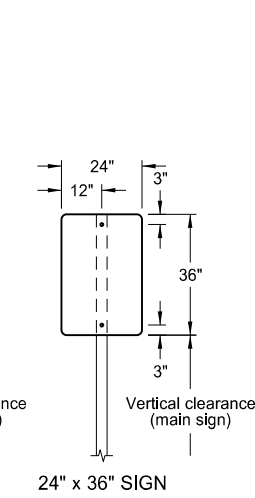
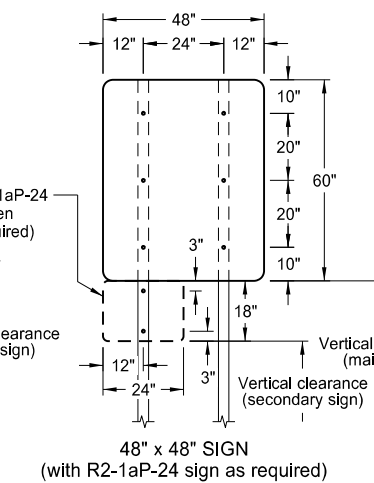
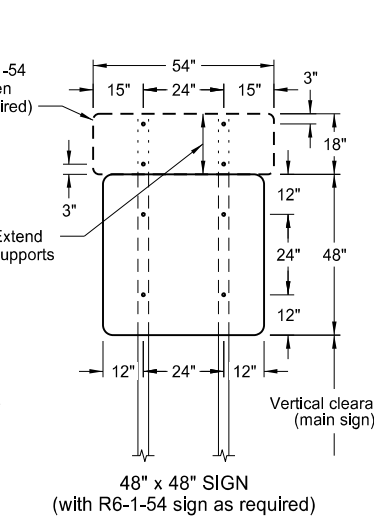
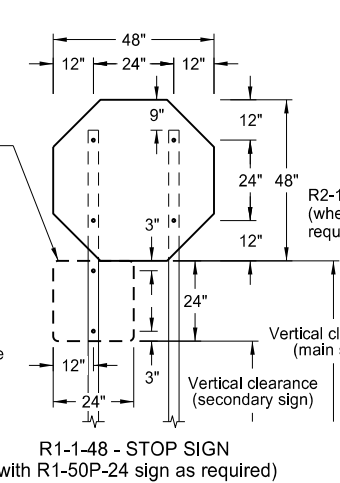
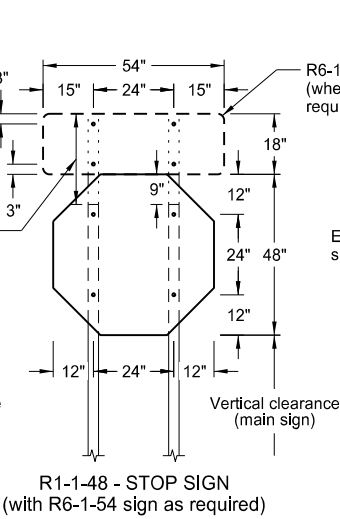
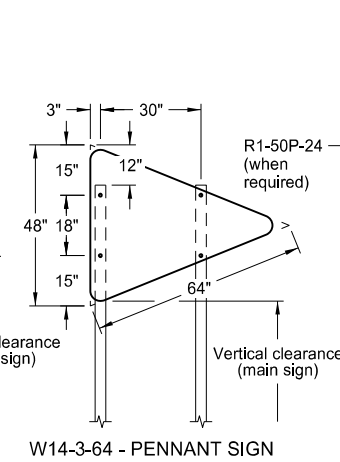
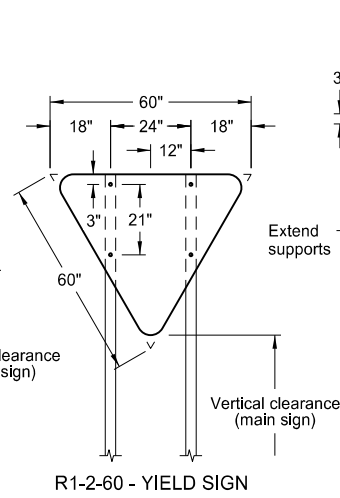
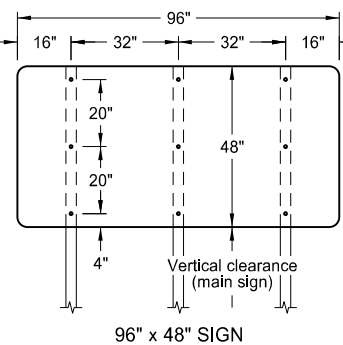
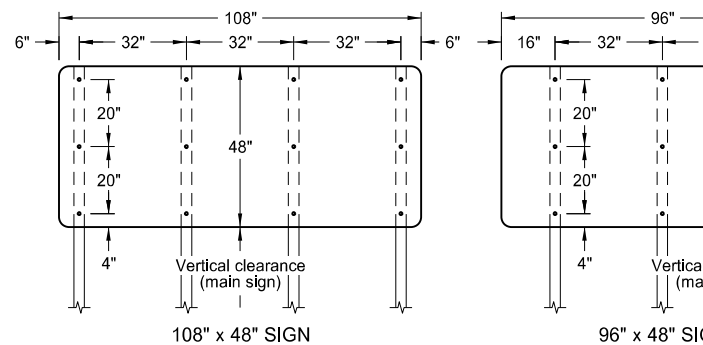
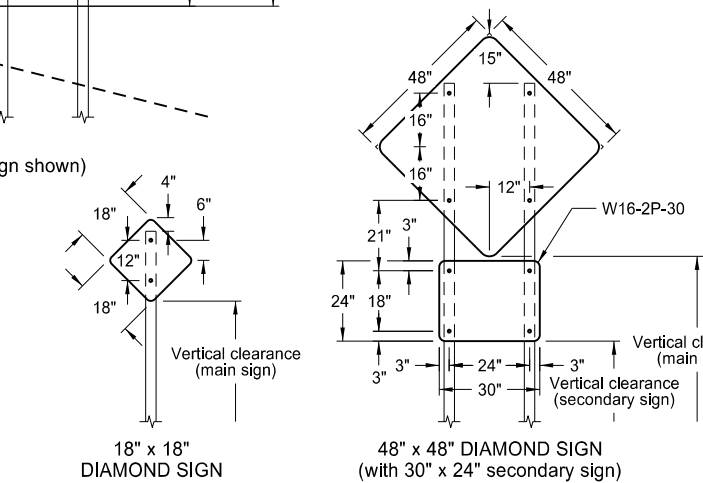
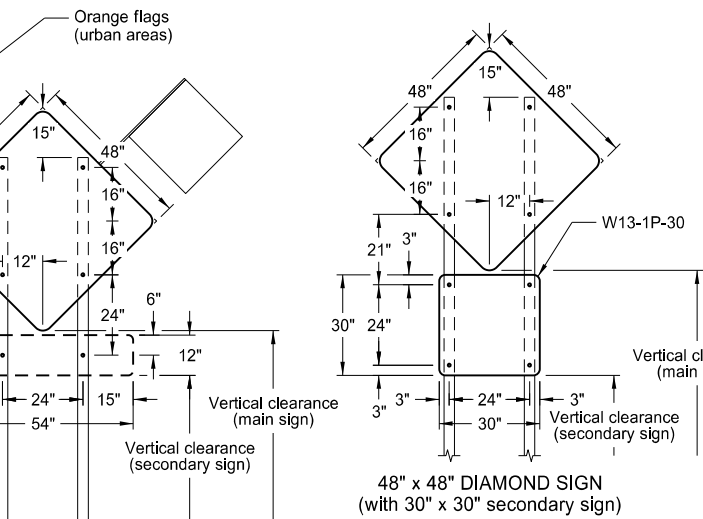
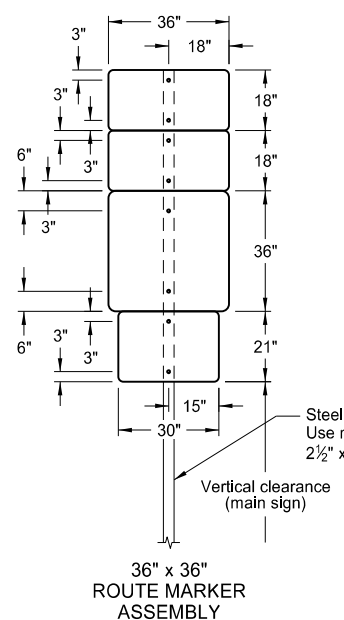
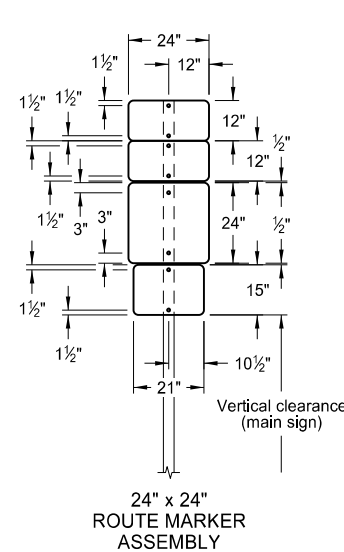

NOTES:

- Sign Supports: Galvanize or paint supports. Minimum post sizes are 2.5 lb/ft u-channel or 2" x 2" x 12 gauge steel perforated tube, except where noted. When installing signs on u-channel, minimum post size for assemblies containing a secondary sign is 3.0 lb/ft. Post sizes based on a wind speed of 55 MPH.

Place signs over 50 square feet on 2 1/2" x 2 1/2" perforated tube supports as a minimum.

Do not attach guy wires to sign supports. Attach wind beams behind sign panels when used with u-posts.
- Sign Panels: Provide sign panels made of 0.100" aluminum, 1/2" plywood, or other approved material, except where noted. Punch all holes round for 5/16" bolts.
- Alternate Messages: Install and remove alternate message signs on reflectorized plate (without borders) as required. (i.e. "Left" and "Right" message on lane closure sign)
- Route Marker Auxiliary Signs: Provide route marker auxiliary signs, such as the cardinal direction and directional arrows, with a background and legend that match the route marker they are used with:

Interstate - white legend on blue background
Interstate Business Loop - white legend on green background
US and State - black legend on white background
County - yellow legend on blue background

- Vertical Clearance: Install signs with a vertical clearance of 5'-0" (see TYPICAL SECTION). In areas where parking or pedestrian movements are likely or the view of the sign may be obstructed, install signs with a vertical clearance of 7'-0" from the top of the curb or from the near edge of the driving lane in absence of a curb.

The vertical clearance to secondary signs is 1'-0" less than the vertical clearance stated above.

Provide a minimum clearance of 7'-0" from the ground at the post for signs with an area exceeding 50 square feet.

- Portable Signs: Provide portable signs that meet the vertical clearance stated above when it is necessary to place signs within the pavement surface.

Use of low-mounting height (minimum 12" vertical clearance) portable signs for 5 days or less, is allowed as long as the view of the sign is not obstructed. Time delays caused by unforeseen circumstances, such as equipment breakdowns, rain, subgrade failures, etc., will not accrue towards the 5 day period. Use of R9-8 through R9-11a series, W1-6 through W1-8 series, M4-10, and E5-1 is allowed for longer than 5 days.

Restrict signs mounted on portable sign supports shown in the LOW-MOUNTING HEIGHT and HIGH-MOUNTING HEIGHT details to a maximum surface area of 16 square feet.

MINIMUM BALLAST
(For each side of sign support base)

Sign Panel Mounting Height (ft)	Number of 25 lb sandbags for 4' x 4' sign panel
1'	6
5'	8
7'	10

Note: The number of sandbags are based on a wind speed of 55 MPH. Place sandbags at or near the ends of skids.

NORTH DAKOTA DEPARTMENT OF TRANSPORTATION	
10-4-13	
REVISIONS	
DATE	CHANGE
11-14-13	Revised Note 6
9-27-17	Updated to active voice
11-01-19	Revised 60"x24" sign detail

This document was originally issued and sealed by
Kirk J Hoff,
Registration Number
PE-4683,
on 11/1/19 and the original document is stored at the North Dakota Department of Transportation

ROAD CLOSURE LAYOUTS

Notes:
1. Variables

- S = Numerical value of speed limit or 85th percentile.
- W = The width of taper in feet.
- L = Minimum length of taper, S x W for freeways, expressways, and other roads with speeds of 45 mph or greater, or W x S²/60 for urban, residential, and other streets with speeds of 40 mph or less.
- 2. Place barricades on moveable assemblies and signs on portable assemblies when located on roadway.
- 3. Place delineator drums, barricades or cones for tapering traffic at dimension "S" and for tangents space at 2 times dimension "S".
- 4. Place Sequencing Arrow Panels at the beginning of the taper when possible. Where shoulder width does not provide sufficient room, move the panel closer to the work area and place on roadway surface. See Shoulder Closure Standard Drawing. Use Type A on roadways with slow moving traffic speeds and low volume (25 mph or less and 750 ADT or less). Use Type B on roadways with moderate traffic speeds and volumes (40 mph or less and 5000 ADT or less). Use Type C on roadways with high traffic speeds and volumes (over 40 mph or over 5000 ADT).
- 5. Re-establish speed. Determine exact speed limit in the field, dependent on location and conditions.
- 6. Determine the reduced speed limit based on the in-place speed limit before construction. Where speed reductions exceed 30 mph, install a second speed limit sign with the desired speed reduction (not to exceed 30 mph.) Place the second speed limit sign at 1/2 B.
- 7. Install flags on warning signs in urban areas when signs are not portable. Mount 24 inch square flags perpendicular to the edges of the sign, and at such a distance above the edge that the flag does not touch the sign when limp.
- 8. Cover existing speed limit signs within reduced speed zones.
- 9. Where necessary, engineer will determine safe speed.
- 10. As an option, use portable sign supports in lieu of post mounted signs in accordance with NDDOT Standard Drawing D-704-14.
- 11. Sign G20-55-96 is not required if this layout is part of other traffic control that contains this sign, or the work is less than 15 days.
- 12. Recommend using 40 mph speed limit in vicinity of workers, unless location and conditions dictate otherwise.
- 13. Sign I2-5-96 is not required if this layout is part of other traffic control that contains this sign.

Road Type	Distance Between Signs Min. (ft)		
	A	B	C
Urban - Low Speed (30 mph or less)	150	150	150
Urban - Low Speed (over 30 to 40 mph)	280	280	280
Urban - High Speed (over 40 mph to 50 mph)	360	360	360
Rural - High Speed (over 50 mph to 65 mph)	720	720	720
Urban Expressway and Freeway (55 mph to 60 mph)	850	1350	2200
Rural Expressway and Freeway (70 mph to 75 mph)	1000	1500	2640
Interstate/4-Lane Divided (Maintenance and Surveying)	750	1000	1500

KEY

	Type III barricade		Work area
	Sign		Flagger
	Delineator drum		Sequencing arrow panel
	Tubular markers		Vertical panels back to back

Speed (mph)	Length Min (feet)
20	115
25	155
30	200
35	250
40	305
45	360
50	425
55	495
60	570
65	645
70	730
75	820

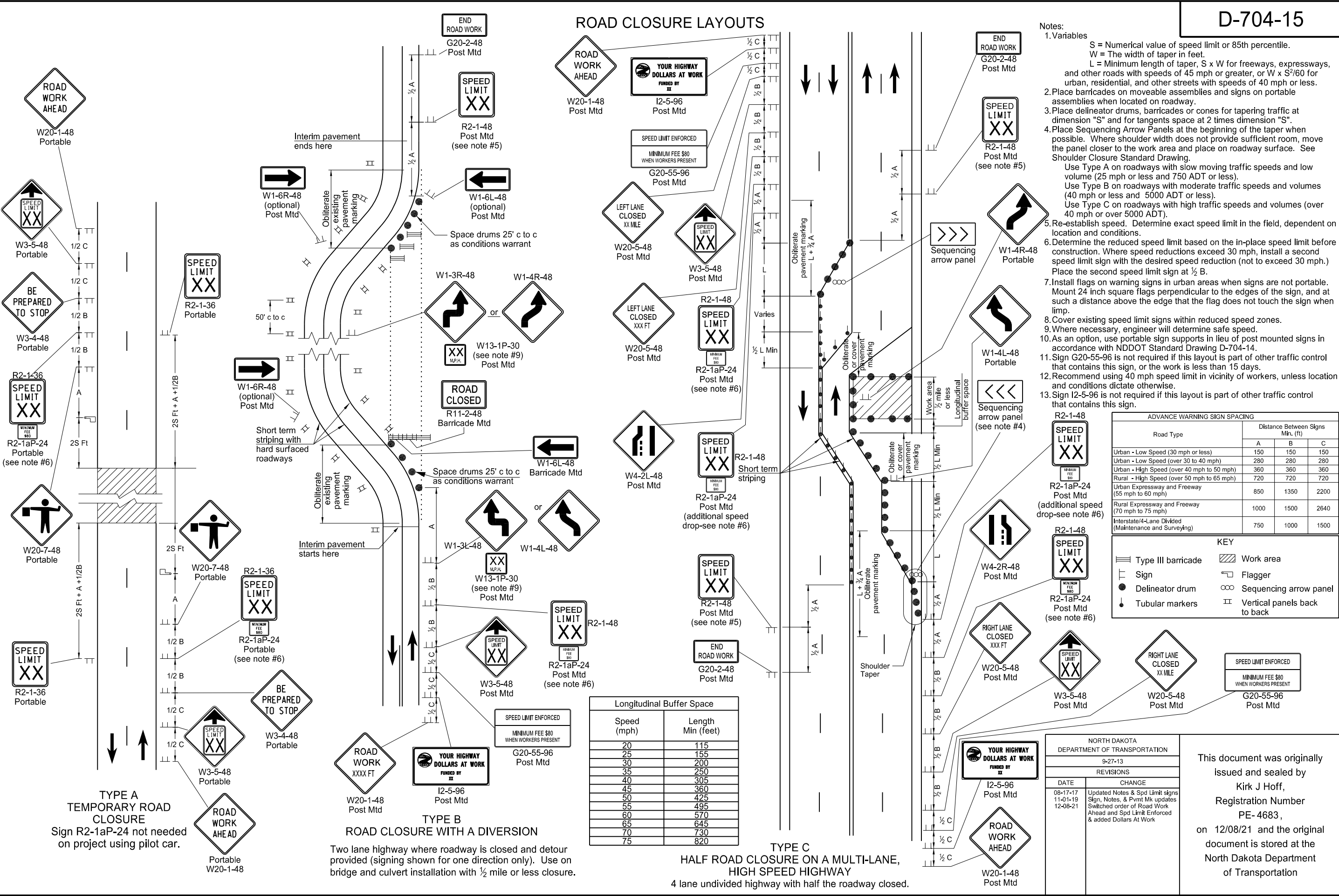

NORTH DAKOTA DEPARTMENT OF TRANSPORTATION	
9-27-13	
REVISIONS	
DATE	CHANGE
08-17-17	Updated Notes & Spd Limit signs
11-01-19	Sign, Notes, & Pmt Mt updates
12-08-21	Switched order of Road Work Ahead and Spd Limit Enforced & added Dollars At Work

This document was originally issued and sealed by Kirk J Hoff, Registration Number PE-4683, on 12/08/21 and the original document is stored at the North Dakota Department of Transportation

TYPE A TEMPORARY ROAD CLOSURE
Sign R2-1aP-24 not needed on project using pilot car.

TYPE B ROAD CLOSURE WITH A DIVERSION
Two lane highway where roadway is closed and detour provided (signing shown for one direction only). Use on bridge and culvert installation with 1/2 mile or less closure.

TYPE C HALF ROAD CLOSURE ON A MULTI-LANE, HIGH SPEED HIGHWAY
4 lane undivided highway with half the roadway closed.

TERMINAL AND SEAL COAT SIGN LAYOUTS

D-704-20

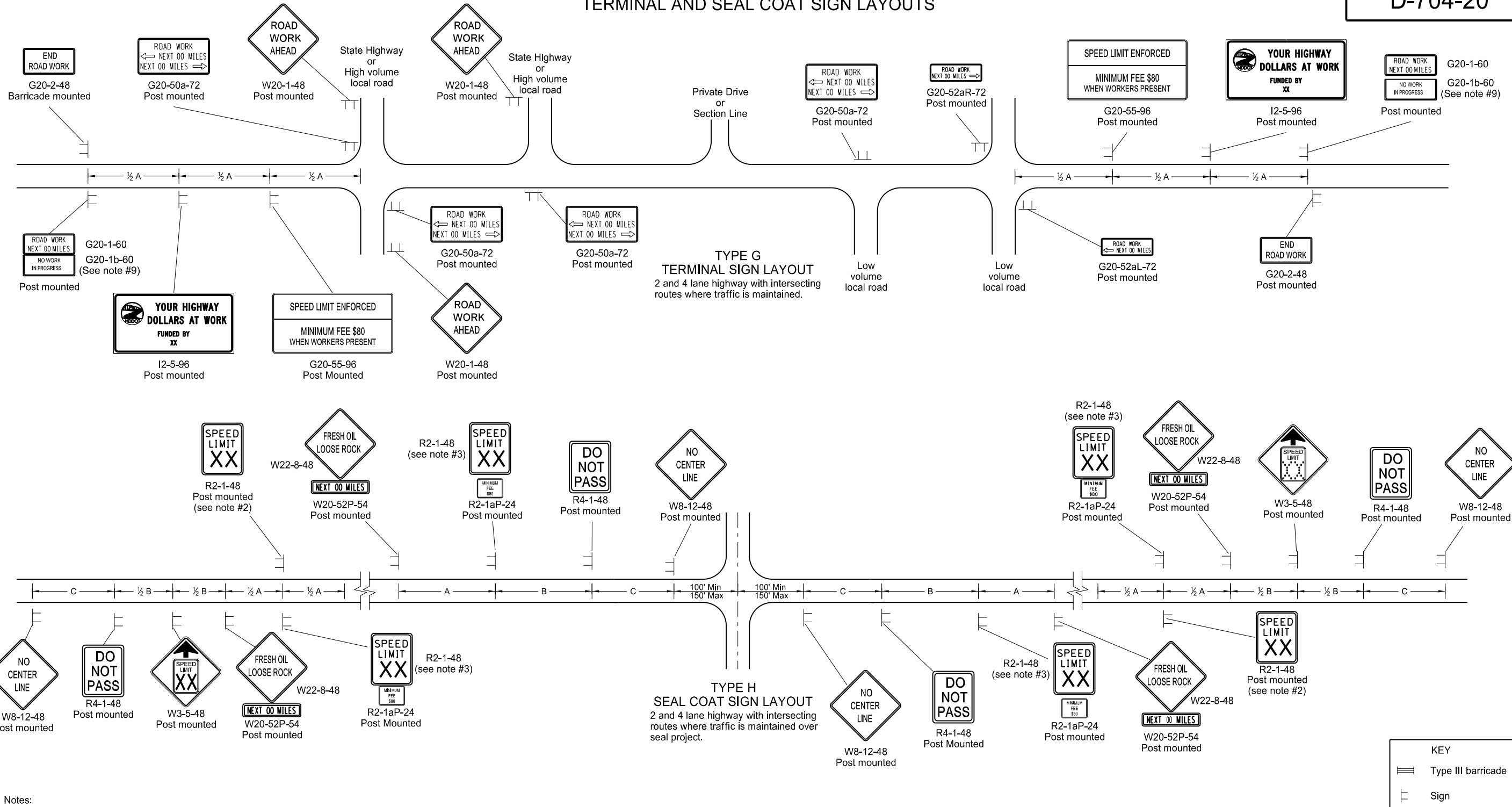

- Notes:
- Place barricades on moveable assemblies and signs on portable assemblies when located on roadway.
 - Determine the exact speed limit in the field, based on location and conditions.
 - Determine the reduced speed limit based on the in place speed limit before construction. Where speed limit reductions exceed 30 MPH, install a second speed limit sign with the desired speed reduction (not to exceed 30 MPH.) Place the second speed limit sign at 1/2 B.
 - Install flags on warning signs in urban areas when signs are not portable. Mount 24 inch square flags perpendicular to the edges of the sign, and at such a distance above the edge that the flag does not touch the sign when limp.
 - Cover existing speed limit signs within a reduced speed zone.
 - On seal coat projects, place signs R2-1-48, R2-1aP-24, R4-1-48, W22-8-48 and W20-52P-54 after all important intersections and at five mile intervals. Place sign W8-12-48 after all important intersections and at 2 mile intervals until short term center line pavement marking is placed.
 - As an option, use portable sign supports in lieu of post mounted signs in accordance with the NDDOT Standard Drawing D-704-14.
 - Cover or remove speed limit signs from layout Type H when loose aggregate is removed.
 - Install sign G20-1b-60 when work is suspended for winter.
 - Use other traffic control layouts in immediate work areas. Place sign R2-1aP-24 below speed limit signs in reduced speed limit work areas.
 - Sign G20-55-96 is not required if this layout is part of other traffic control that contains this sign, or the work is less than 15 days.
 - Recommend using 40 mph speed limit in vicinity of workers, unless location and conditions dictate otherwise.
 - Sign I2-5-96 is not required if this layout is a part of other traffic control that contains this sign.

ADVANCE WARNING SIGN SPACING			
Road Type	Distance Between Signs Min. (ft)		
	A	B	C
Urban - Low Speed (30 mph or less)	150	150	150
Urban - Low Speed (over 30 to 40 mph)	280	280	280
Urban - High Speed (over 40 mph to 50 mph)	360	360	360
Rural - High Speed (over 50 mph to 65 mph)	720	720	720
Urban Expressway and Freeway (55 mph to 60 mph)	850	1350	2200
Rural Expressway and Freeway (70 mph to 75 mph)	1000	1500	2640
Interstate/4-Lane Divided (Maintenance and Surveying)	750	1000	1500

NORTH DAKOTA DEPARTMENT OF TRANSPORTATION	
9-27-13	
REVISIONS	
DATE	CHANGE
08-17-17	Updated notes & sign numbers
11-01-19	Updated note & sign
12-08-21	Switched order of Road Work and Spd Limit Enforced & added Dollars At Work

This document was originally issued and sealed by Kirk J Hoff, Registration Number PE-4683, on 12/08/21 and the original document is stored at the North Dakota Department of Transportation

CONSTRUCTION TRUCK AND TEMPORARY DETOUR LAYOUTS

D-704-22

KEY	
	Type III barricade
	Sign
	Work area
	Flagger

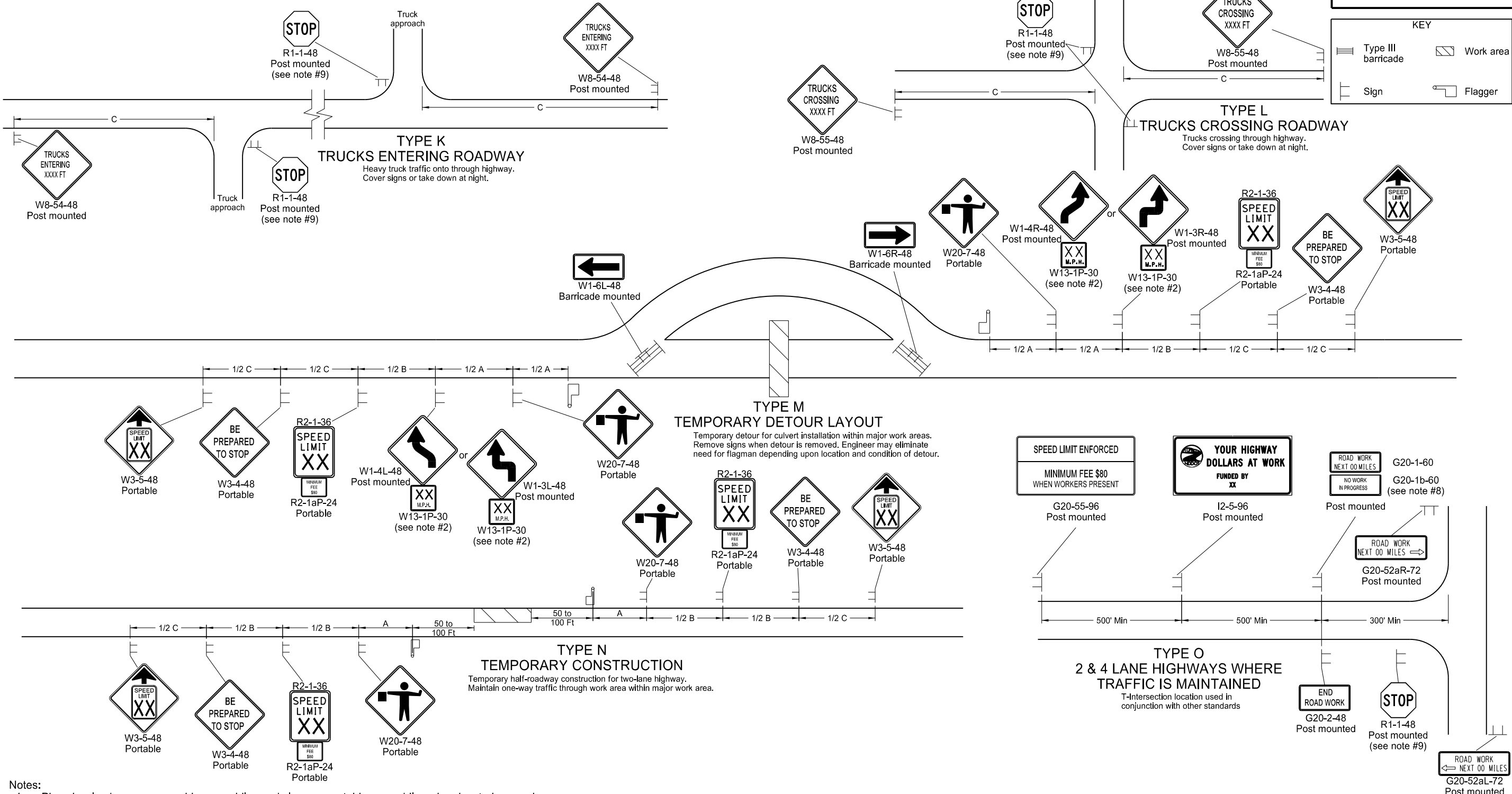

- Notes:
- Place barricades on a moveable assemblies and signs on portable assemblies when located on roadway.
 - Where necessary, safe speed to be determined by the Engineer.
 - Determine the reduced speed limit based on the in-place speed limit before construction. Where speed reductions exceed 30 mph, install a second speed limit sign with the desired speed reduction (not to exceed 30 mph.) Place the second speed limit sign at 1/2 B.
 - Install flags on warning signs in urban areas when signs are not portable. Mount 24 inch square flags perpendicular to the edges of the sign, and at such a distance above the edge that the flag does not touch the sign when limp.
 - Cover existing speed limit signs within a reduced speed zone.
 - Covered (when approved by engineer) or obliterated pavement marking measured as Obliteration of Pavement Marking.
 - As an option, use portable sign supports in lieu of post mounted signs in accordance with NDDOT Standard Drawing D-704-14.
 - Install sign G20-1b-60 when work is suspended for winter.
 - If existing stop sign is in place, a 48" stop sign is not required.
 - Sign G20-55-96 is not required if layout is part of other traffic control that contains this sign, or if work is less than 15 days.
 - Recommend using 40 mph speed limit in vicinity of workers, unless location and conditions dictate otherwise.
 - Sign I2-5-96 is not required if layout is part of other traffic control that contains this sign.

Road Type	Distance Between Signs Min. (ft)		
	A	B	C
Urban - Low Speed (30 mph or less)	150	150	150
Urban - Low Speed (over 30 to 40mph)	280	280	280
Urban - High Speed (over 40 mph to 50 mph)	360	360	360
Rural - High Speed (over 50 mph to 65 mph)	720	720	720
Urban Expressway and Freeway (55 mph to 60 mph)	850	1350	2200
Rural Expressway and Freeway (70 mph to 75 mph)	1000	1500	2640
Interstate/4-Lane Divided (Maintenance and Surveying)	750	1000	1500

NORTH DAKOTA
DEPARTMENT OF TRANSPORTATION
9-27-13

REVISIONS	
DATE	CHANGE
08-17-17	Update notes & sign numbers
11-01-19	Revised sign numbers & note 7
12-09-21	Added Speed Limit Enforced and Dollars At Work signs

This document was originally issued and sealed by
Kirk J Hoff,
Registration Number
PE-4683,
on 12/09/21 and the original document is stored at the North Dakota Department of Transportation

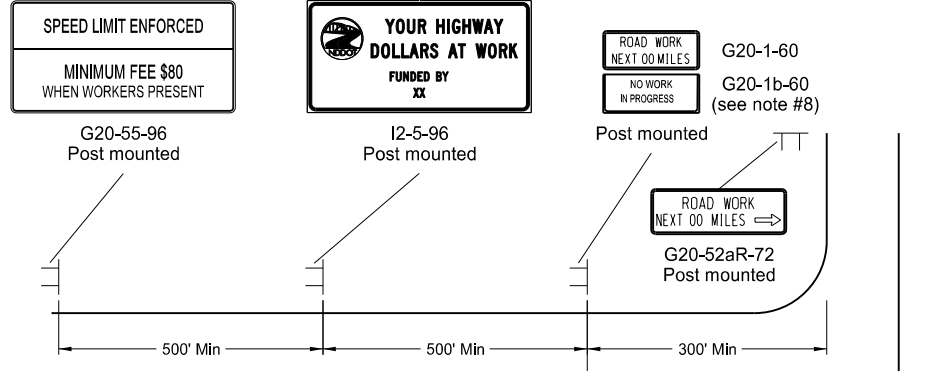

MOBILE OPERATION
(PAVEMENT MARKING)

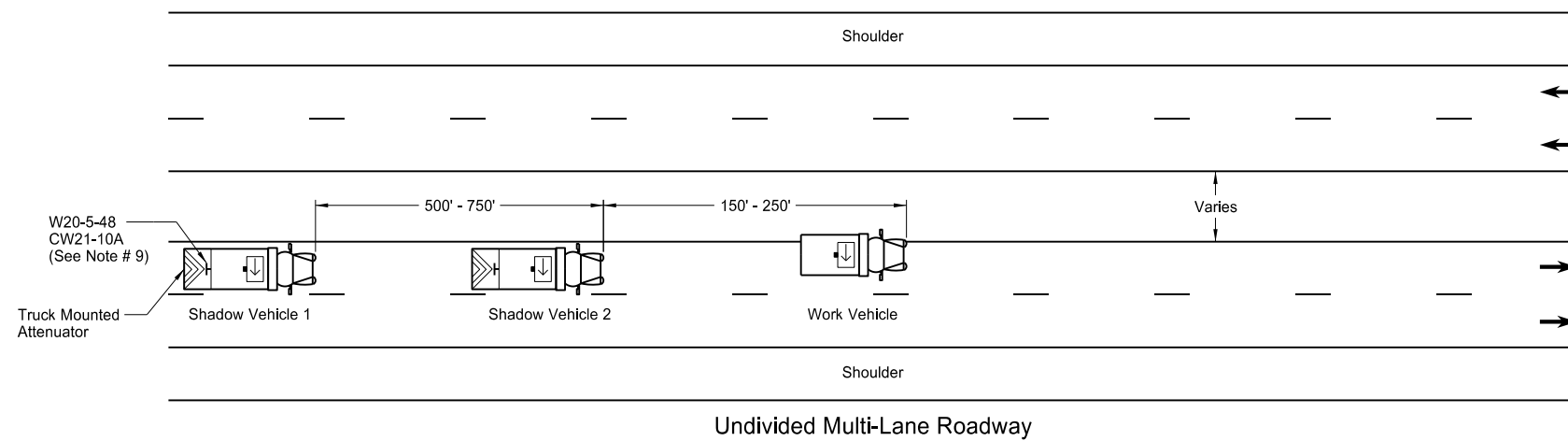
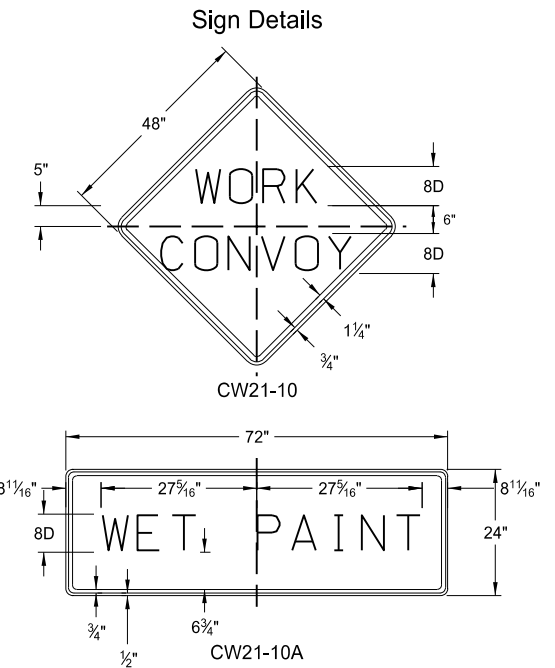
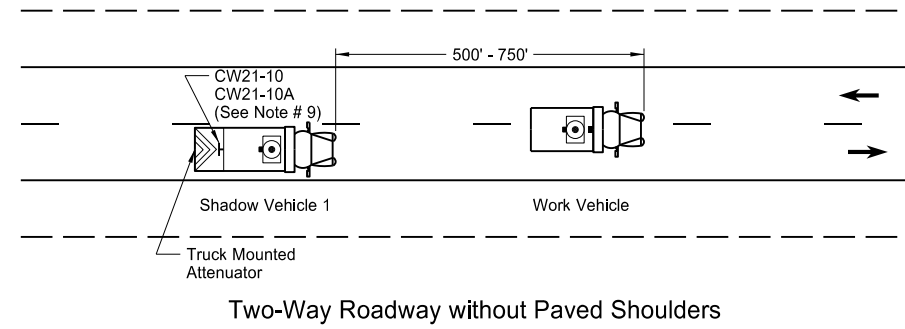
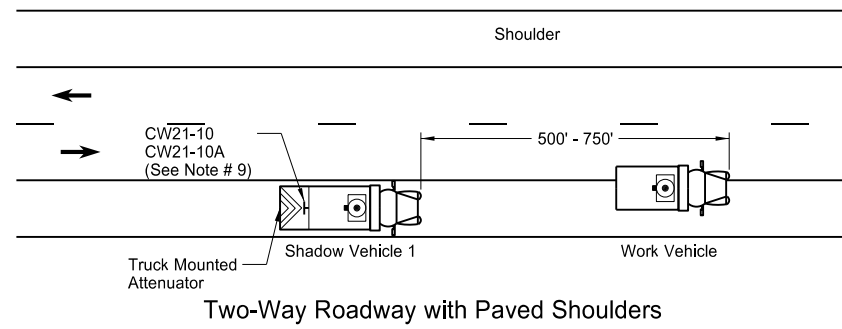
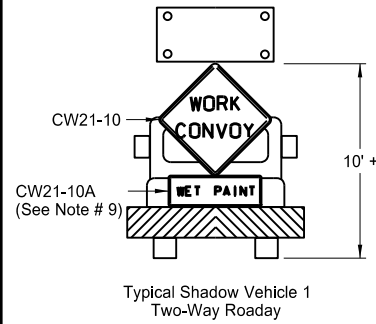

- Notes
- Use additional vehicles you choose to be in the convoy with truck mounted attenuators, at your own expense.
 - Display yellow rotating beacons or strobe lights on shadow and work vehicles, unless otherwise stated in the plans.
 - Use Type B or Type C flashing arrow panels controlled from inside the vehicle.
 - Provide each vehicle with two-way electronic communication capability.
 - Move shadow vehicle 1 first to shadow other convoy vehicles when convoy changes lane.
 - Vary vehicle spacing between shadow vehicle 1 and shadow vehicle 2 based on sight distance restrictions. Motorists approaching the work convoy need to see trail vehicle in time to slow down and/or change lanes as they approach shadow vehicle.
 - Sign Colors
Letters = Black
Border = Black
Background = Orange
 - As an option, use shadow vehicle 2 the paint tender vehicle.
 - Use sign CW21-10A only during painting operation.
 - Pull over work and shadow vehicles periodically to allow motor vehicle traffic to pass on two lane - two way roadways.

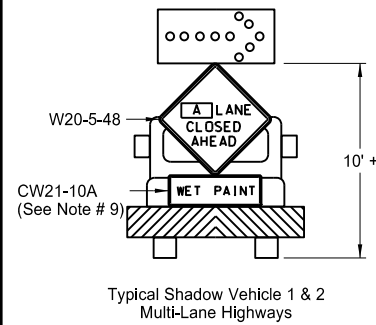

A = Left Right Center

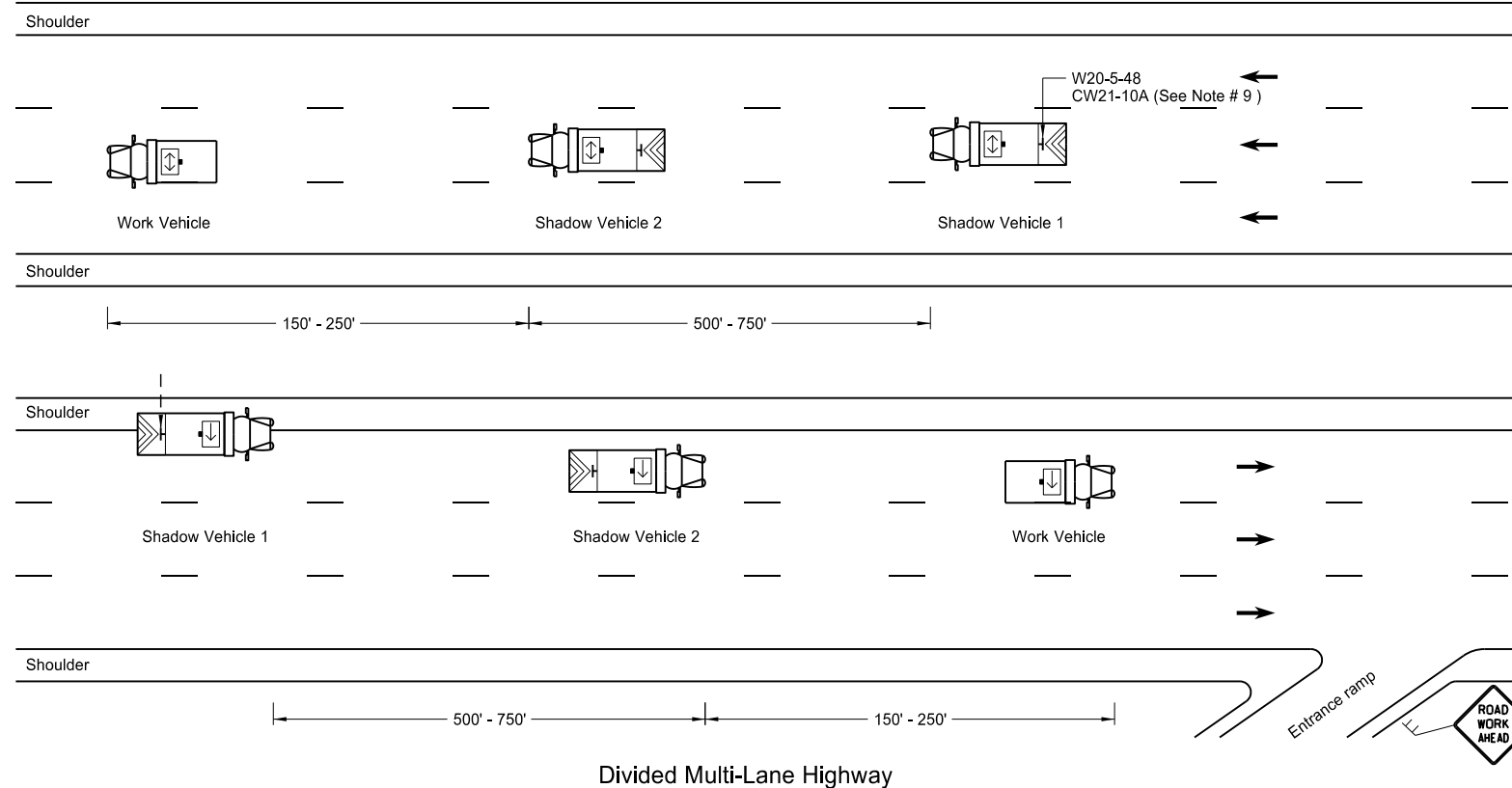

KEY	
	Sign
	Truck mounted attenuator
	Flashing arrow panels:
	Right directional
	Left directional
	Double arrow directional
	Caution Mode

NORTH DAKOTA DEPARTMENT OF TRANSPORTATION	
9-27-13	
REVISIONS	
DATE	CHANGE
6-18-14	Removed shadow vehicle 2 on two lane roadways
9-27-17	Updated to active voice
11-08-19	Changed Standard Heading

This document was originally issued and sealed by
Kirk J Hoff,
Registration Number
PE- 4683,
on 11/08/19 and the original document is stored at the North Dakota Department of Transportation

PORTABLE SIGN SUPPORT ASSEMBLY

D-704-50

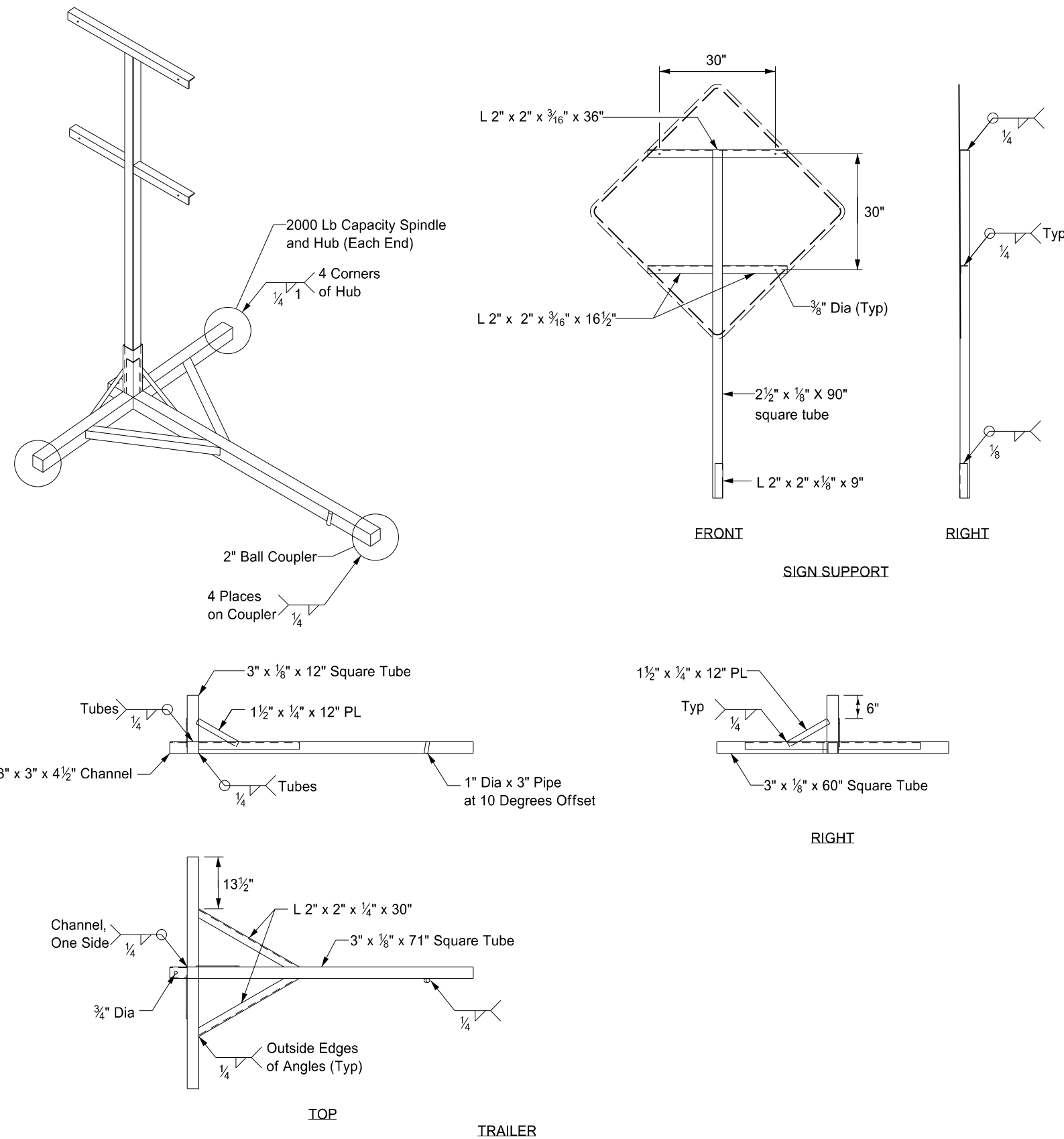

Notes:

- ① Maximum 250 pound weight of assembly.
- ② Use a 14" wheel and tire.
- ③ Use no automotive and equipment axle assemblies for trailer-mounted sign supports.
- ④ Other NCHRP 350 or MASH crash tested assemblies are acceptable.

NORTH DAKOTA DEPARTMENT OF TRANSPORTATION	
11-23-10	
REVISIONS	
DATE	CHANGE
12/02/2020	Updated Note to active voice.

KIRK J. HOFF
REGISTERED
Kirk J Hoff
PROFESSIONAL
PE-4683
ENGINEER
NORTH DAKOTA
12 02 2020

PAVEMENT MARKING

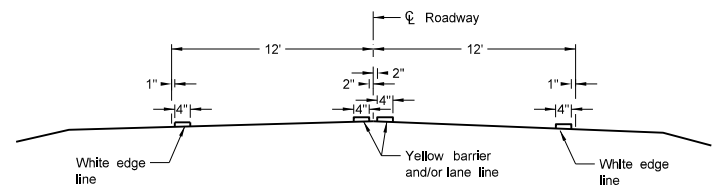

Two Lane Two Way
RURAL ROADWAY

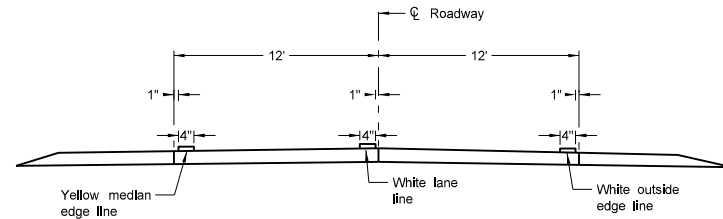

Two Lane Roadway
INTERSTATE HIGHWAY
Concrete Section

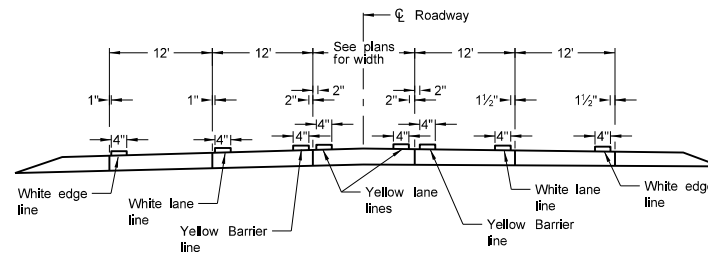

RURAL FIVE LANE ROADWAY
Concrete Section

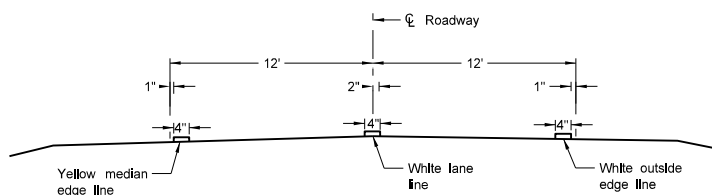

Two Lane Divided
Rural Roadway
PRIMARY HIGHWAY
Asphalt Section

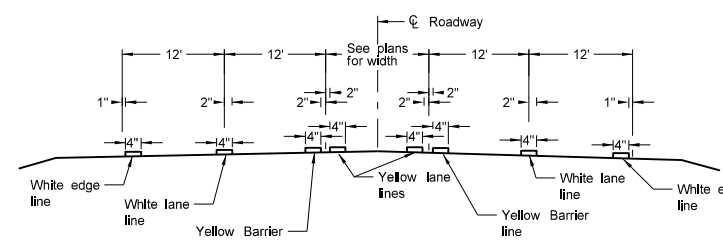

RURAL FIVE LANE ROADWAY
Asphalt Section

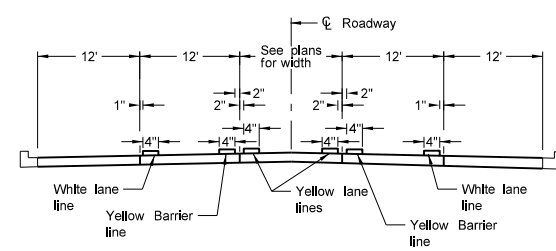

URBAN FIVE LANE SECTION
Concrete Section

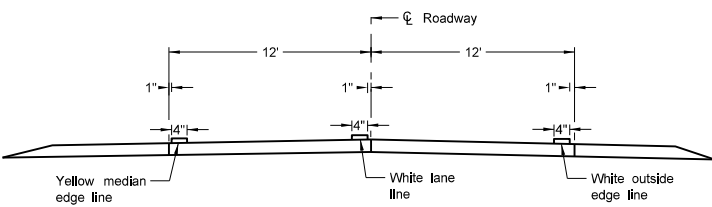

Two Lane Roadway
PRIMARY HIGHWAY
Concrete Section

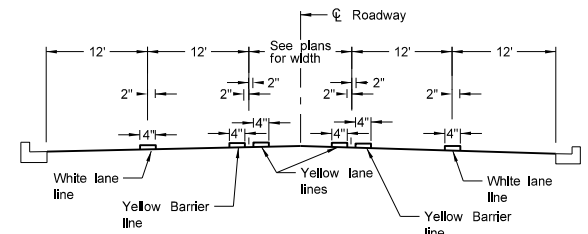

URBAN FIVE LANE SECTION
Asphalt Section

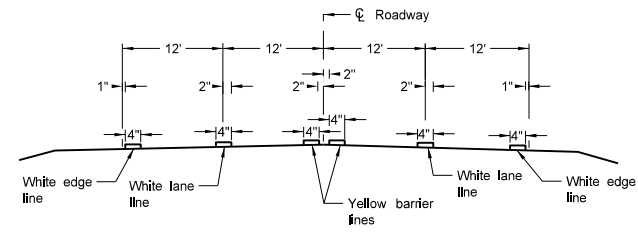

RURAL FOUR LANE ROADWAY
Asphalt Section

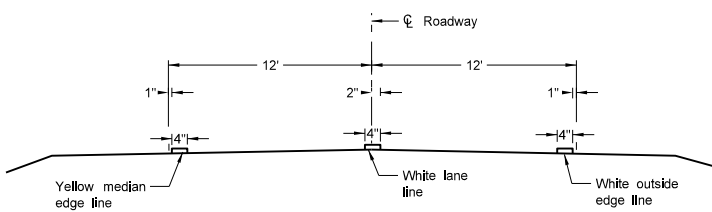

Two Lane Roadway
INTERSTATE HIGHWAY
Asphalt Section

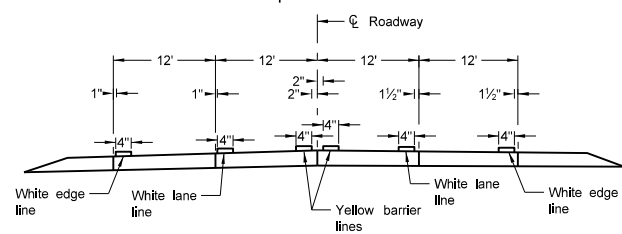

RURAL FOUR LANE ROADWAY
Concrete Section

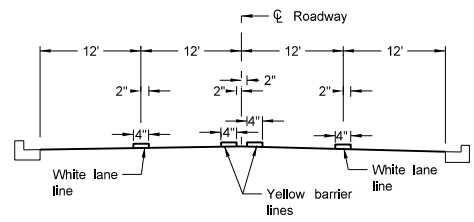

URBAN FOUR LANE SECTION
Asphalt Section

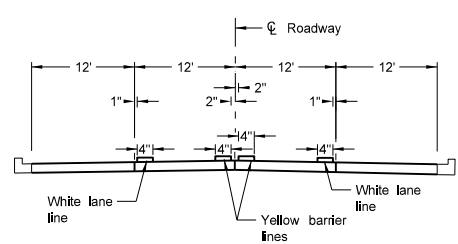

URBAN FOUR LANE SECTION
Concrete Section

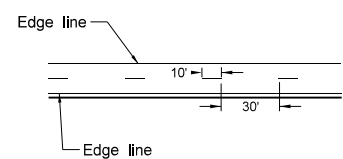

CENTERLINE PAVEMENT MARKING SKIP SPACING DETAIL

NOTES:
1. Continue edge lines through private drives and field drives. Break edge lines for intersections.

NORTH DAKOTA DEPARTMENT OF TRANSPORTATION	
12-1-10	
REVISIONS	
DATE	CHANGE
10-17-17	Updated to active voice.
08-27-19	New Design Engineer PE Stamp.

This document was originally issued and sealed by Kirk J Hoff, Registration Number PE-4683, on 8/27/19 and the original document is stored at the North Dakota Department of Transportation

SHORT-TERM PAVEMENT MARKING

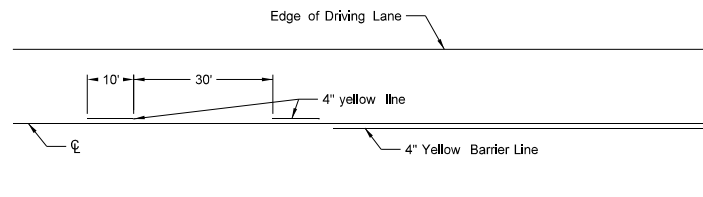

Painted or Tape Lines

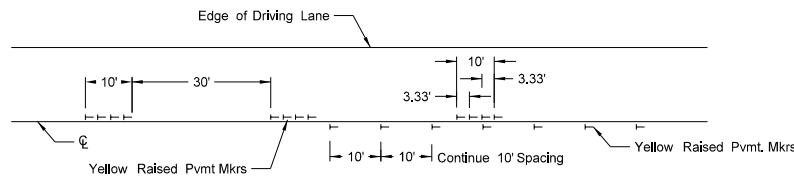

Raised Pavement Markers

TWO-LANE TWO-WAY ROADWAY

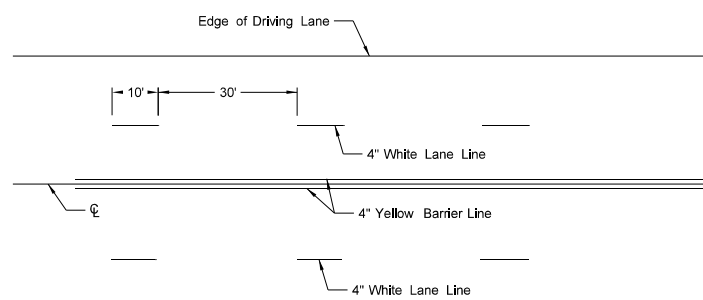

Painted or Tape Lines

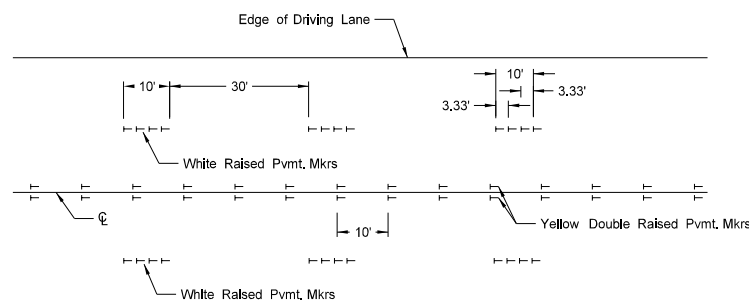

Raised Pavement Markers

FOUR LANE ROADWAY



Painted or Tape Lines

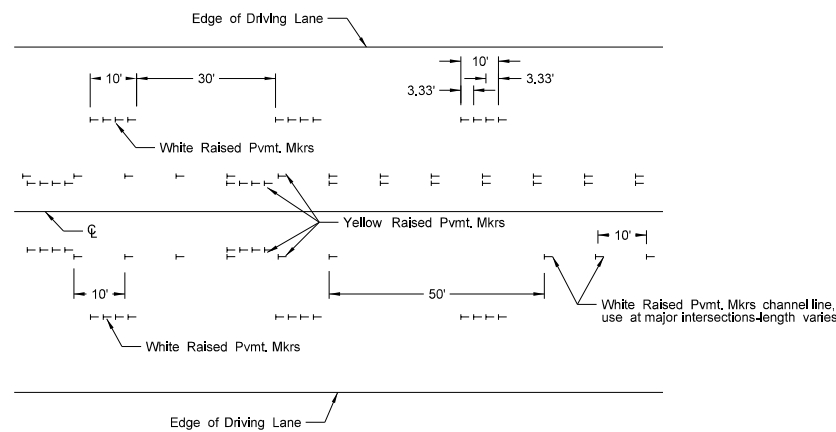

Raised Pavement Markers

FIVE LANE ROADWAY TWO WAY LEFT TURN

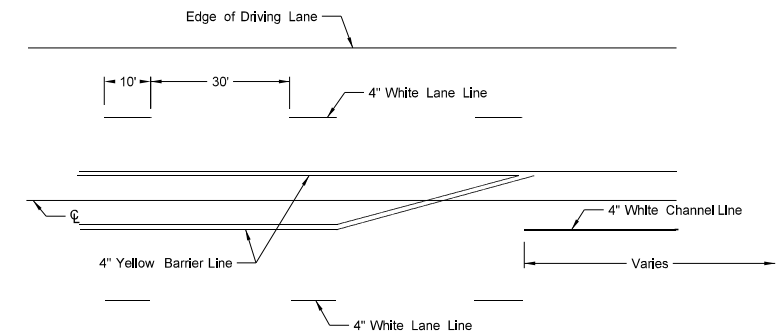

Painted or Tape Lines

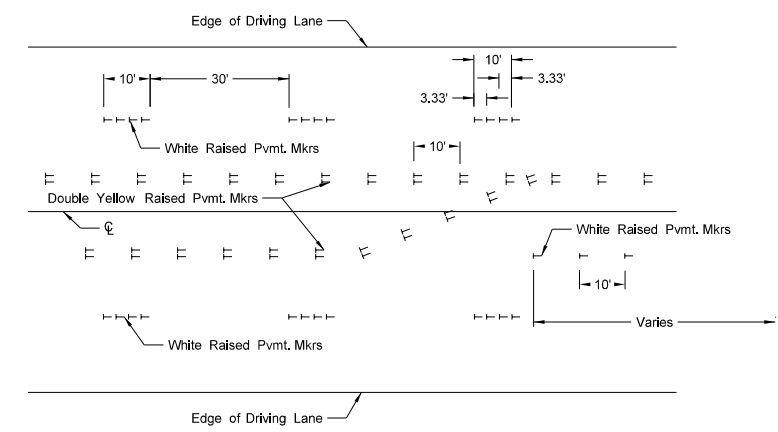

Raised Pavement Markers

FIVE LANE ROADWAY WITH MARKED ISLANDS

NOTES:

1. Place no passing zones on two-lane two-way roadways as shown. In lieu of short term no passing zone pavement markings, place no passing zone signs. Replace no passing zone signs with short term no passing zone pavement marking within three days.
2. Place short term center line stripe (paint) on top lift to match exact placement of permanent stripe.
3. Remove raised markers and tape markings after permanent pavement marking is installed.

NORTH DAKOTA DEPARTMENT OF TRANSPORTATION	
12-1-10	
REVISIONS	
DATE	CHANGE
3-29-16	Re-numbered to be D-762-11 (previously was D-762-6)
10-17-17	Updated to active voice.
8-27-19	New Design Engineer PE Stamp.

This document was originally issued and sealed by
 Kirk J Hoff,
 Registration Number
 PE-4683,
 on 8/27/19 and the original document is stored at the North Dakota Department of Transportation