

DESIGN DATA			
Traffic	Average Daily		
Current	Pass: 246	Trucks: 72	Total: 318
Preventive Maintenance			

JOB # 28 NORTH DAKOTA DEPARTMENT OF TRANSPORTATION

STATE	PROJECT NO.	PCN	SECTION NO.	SHEET NO.
ND	SS-1-014(008)021	22365	1	1

SS-1-014(008)021
Burleigh & Sheridan Counties
Jct ND 36 N to Jct ND 200
Chip Seal

GOVERNING SPECIFICATIONS:
2014 Standard Specifications adopted by the North Dakota Department of Transportation and the Supplemental Specifications effective on the date the project is advertised.

PROJECT NUMBER \ DESCRIPTION	NET MILES	GROSS MILES
SS-1-014(008)021	24.471	24.471

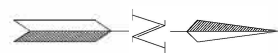

Begin Project SS-1-014(008)021
RP 21.291
Sec. 3, T142N, R76W

End Project SS-1-014(008)021
RP 45.762
Sec. 8, T146N, R75W

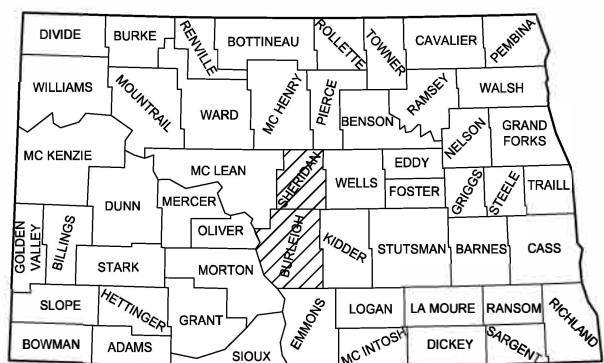

STATE COUNTY MAP

DESIGNER Grant Zinke
DESIGNER Jordan M. Nehls, P.E.
DESIGNER

ND DEPARTMENT OF TRANSPORTATION
BISMARCK DISTRICT
Larry J. Gangl 11/22/19

NDDOT BISMARCK DISTRICT

This document was originally issued and sealed by Tyler W. Wollmuth, Registration Number PE- 6080, on 11/22/19 and the original document is stored at the North Dakota Department of Transportation

TABLE OF CONTENTS

	STATE	PROJECT NO.	SECTION NO.	SHEET NO.
	ND	SS-1-014(008)021	2	1

PLAN SECTIONS

Section	Page(s)	Description
1	1	Title Sheet
2	1	Table of Contents
6	1	Notes
8	1	Quantities
10	1	Basis of Estimate
20	1	General Details
30	2	Typical Sections
100	3	Work Zone Traffic Control

LIST OF STANDARD DRAWINGS

Number	Description
D-101-1, 2,3	NDDOT Abbreviations
D-101-10	NDDOT Utility Company and Organization Abbreviations
D-101-20, 21	Line Styles
D-101-30, 31,32	Symbols
D-704-7	Breakaway Systems For Construction Zone Signs - Perforated Tube
D-704-8	Breakaway Systems For Construction Zone Signs - U-Channel Post
D-704-9, 10,11	Construction Sign Details - Terminal And Guide Signs
D-704-14	Construction Sign Punching And Mounting Details
D-704-15	Road Closure Layouts
D-704-20	Terminal And Seal Coat Sign Layouts
D-704-22	Construction Truck And Temporary Detour Layouts
D-704-26	Miscellaneous Sign Layouts
D-704-27	Traffic Control Plan For Moving Operations
D-704-50	Portable Sign Support Assembly
D-762-4	Pavement Marking
D-762-11	Short-Term Pavement Marking

SPECIAL PROVISIONS

Number	Description
SP 5299(14)	Permits and Environmental Considerations

NOTES

STATE	PROJECT NO.	SECTION NO.	SHEET NO.
ND	SS-1-014(008)021	6	1

401-P01 FOG SEAL: Apply the fog seal with the following requirements:

1. Apply the fog seal after the final sweeping of the chip seal.
2. The dilution of the fog seal is 50% water and 50% CSS-1H.

704-P02 TRAFFIC CONTROL FOR SEAL COAT: Install and maintain a 55 MPH speed limit during and after the chip seal application. Re-establish the speed limit to pre-construction condition after the fog seal.

420-P01 COVER COAT MATERIAL: Cover coat will be paid at actual quantity used up to plan quantity unless otherwise directed by the Engineer.

704-500 PORTABLE RUMBLE STRIPS (PRS): Use PRS made of rubber or engineered polymers.

Install PRS that meet the following criteria:

- Have no adhesives or fasteners required for placement;
- Have a manufacture's speed rating that meets or exceeds the posted speed limit; and
- Each strip in the array must weigh a minimum of 100 pounds.

Use individual PRS constructed in one of the following manners:

- A single piece;
- Inter locking segments; or
- Two pieces hinged at the midpoint.

An installed array of PRS consists of a minimum of 3 individual strips.

Move rumble strips with the flagging operation. Do not place rumble strips on horizontal curves.

The Engineer will count and measure each array as one unit. Include the cost of providing, installing, maintaining, and relocating PRS in the unit price bid for "Portable Rumble Strips".

704-P01 TRAFFIC CONTROL FOR SEAL COATS: Provide traffic control consisting of a temporary lane closure, flagging, and a pilot car.

Traffic control device quantities are based on a 6 mile limitation and following list:

1. Standard D-704-15, layout A, place layout A at both ends of the work zone. Flagging stations located within the work zone require sign W20-7-48 only;
2. Standard D-704-20, layout H, see sheet 100-2 for locations; and
3. Standard D-704-22, layouts K and L.

This document was originally issued and sealed by Jordan M. Nehls, Registration Number PE-8782, on 11/22/2019 and the original document is stored at the North Dakota Department of Transportation.

ESTIMATE OF QUANTITIES

STATE	PROJECT NO.	SECTION NO.	SHEET NO.
ND	SS-1-014(008)021	8	1

SPEC CODE	ITEM DESCRIPTION	UNIT	MAINLINE	TOTAL
-----	-----	-----	-----	-----
103	0100 CONTRACT BOND	L SUM	1	1
401	0070 FOG SEAL	GAL	23,625	23,625
420	0111 CRS2P EMULSIFIED ASPHALT	GAL	170,069	170,069
420	0125 COVER COAT MATERIAL CL 41	TON	4,898	4,898
702	0100 MOBILIZATION	L SUM	1	1
704	1000 TRAFFIC CONTROL SIGNS	UNIT	2,846	2,846
704	1048 PORTABLE RUMBLE STRIPS	EA	4	4
762	0430 SHORT TERM 4IN LINE-TYPE NR	LF	181,664	181,664
762	1104 PVMT MK PAINTED 4IN LINE	LF	349,425	349,425

BASIS OF ESTIMATE

STATE	PROJECT NO.	SECTION NO.	SHEET NO.
ND	SS-1-014(008)021	10	1

Mainline					
Material	Basis	Unit	Width (ft)	Unit/Mile	Total
CRS2P Emulsified Asphalt (Typical Section 1)	0.40 Gal/SY	GAL	29	6,805	164,408
CRS2P Emulsified Asphalt (Typical Section 2)	0.40 Gal/SY	GAL	40.5	9,504	2,956
Cover Coat Material CI 41 (Typical Section 1)	23 LB/SY	TON	29	196	4,735
Cover Coat Material CI 41 (Typical Section 2)	23 LB/SY	TON	40.5	273	85
Fog Seal (Typical Section 1)	0.05 Gal/SY	GAL	32	939	22,686
Fog Seal (Typical Section 2)	0.05 Gal/SY	GAL	43.5	1,276	397

Short Term Pavement Marking			
Mainline (2 applications)	Basis	Unit	Total LF / App
Centerline Skips – Short Term 4 IN Line – Type NR Yellow	Measured	LF	31,221
Centerline Barrier – Short Term 4 IN Line – Type NR Yellow	Measured	LF	59,611
1 st Application After Chip Seal	Total / App		90,832
2 nd Application After Fog Seal	Total		181,664

Permanent Pavement Marking		
Mainline	Basis	Total
Centerline Skips – Pvmt MK Painted 4 IN Line Yellow	Measured	31,221 LF
Centerline Barrier – Pvmt MK Painted 4 IN Line Yellow	Measured	59,611 LF
Edge Lines – Pvmt MK Painted 4 IN Line White	Measured	258,593 LF

This document was originally issued and sealed by Jordan M. Nehls, Registration Number PE-8782, on 11/22/19 and the original document is stored at the North Dakota Department of Transportation.

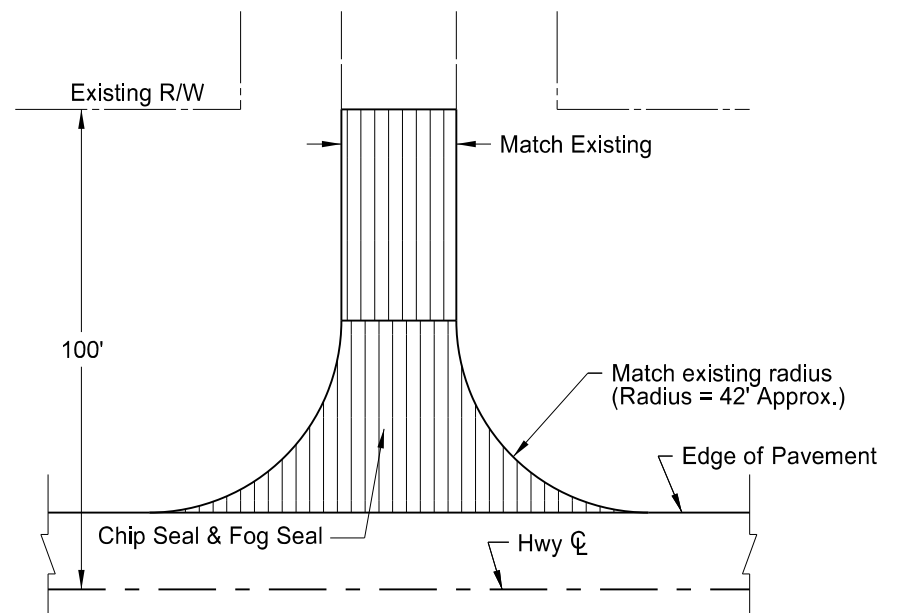

(1) Paved Section Line, County Road, or Street Approach

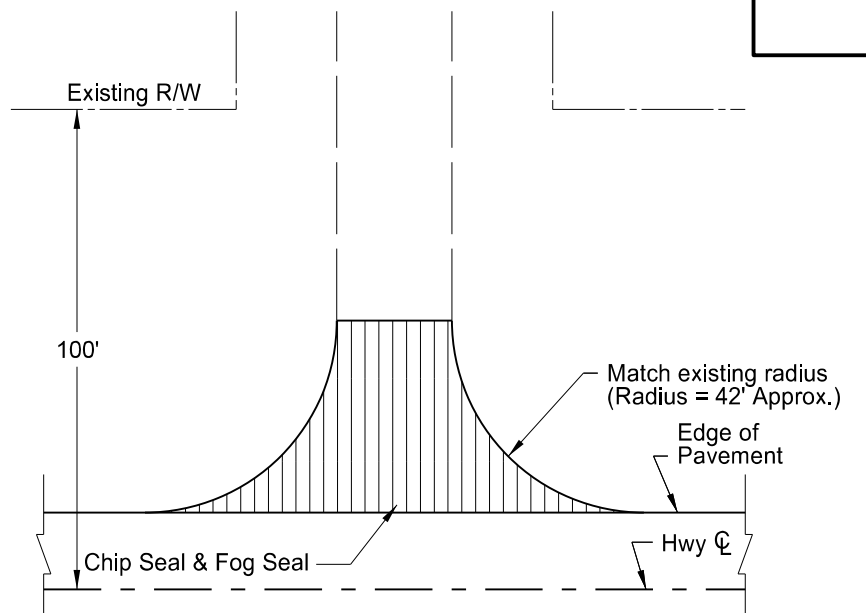

(2) Gravel Section Line, County Road, or Street Approach

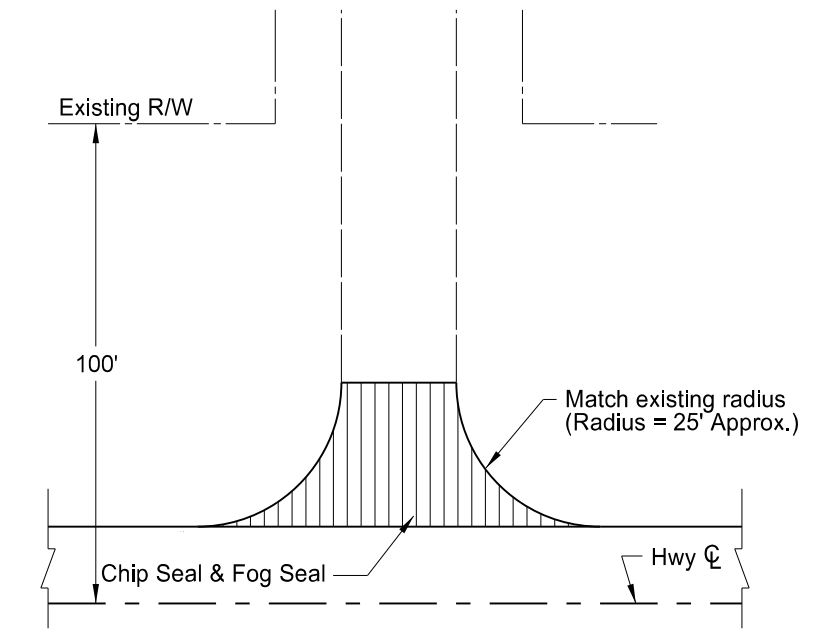

(3) Paved Private Drive Approach

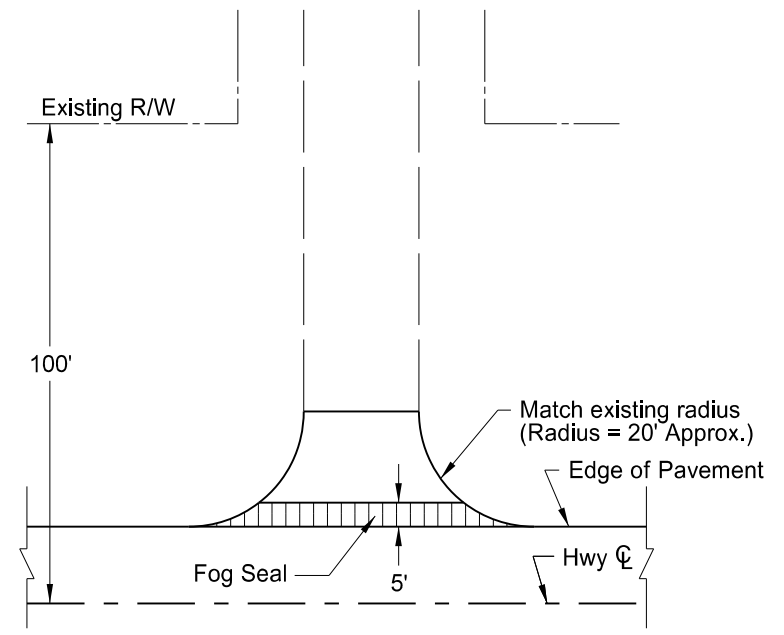

(4) Gravel Private or Field Drive Approach

Notes:

- Actual chip seal and fog seal locations may vary in the field, as approved by the Engineer.
- Quantity totals have been included in the bid items of the "Estimate of Quantities" of the plans.

BASIS OF ESTIMATE		(1)	(2)	(3)	(4)	TOTALS
ITEM	UNIT	Paved Section Line	Gravel Section Line	Paved Private Drive	Gravel Field/Private Drive	
Number of Locations	#	13	13	4	103	133
CRS2P Emulsified Asphalt @ 0.40 Gal/SY	GAL	120	73	49	N/A	2705
Cover Coat Material CL 41 @ 23 lb/SY	TON	3.5	2.1	1.4	N/A	78
Fog Seal @ 0.05 Gal/SY	GAL	15	9	6	2	542

This document was originally issued and sealed by Jordan M. Nehls, Registration Number PE- 8782, on 11/22/19 and the original document is stored at the North Dakota Department of Transportation

Approach Details

Chip Seal
ND Highway 14, From Wing N to Hwy 200

	STATE	PROJECT NO.	SECTION NO.	SHEET NO.
	ND	SS-1-014(008)021	30	1

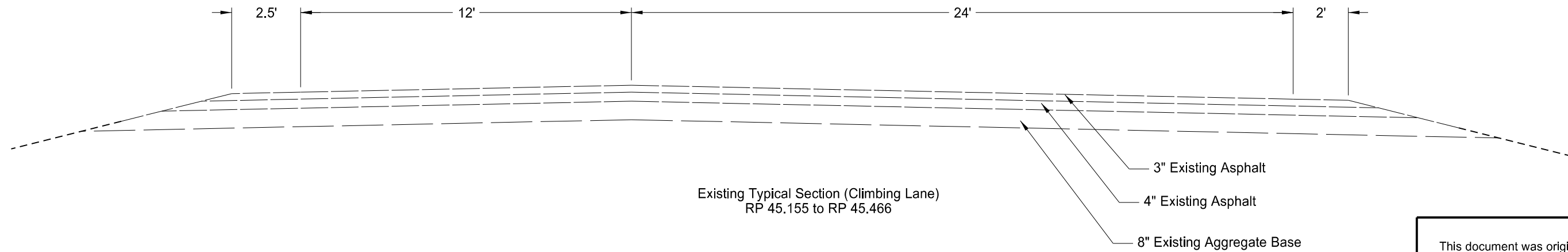
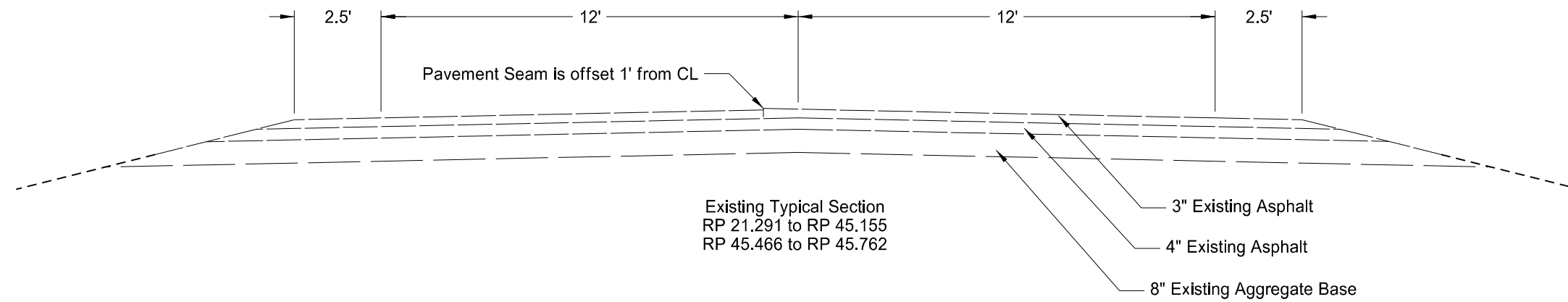

This document was originally issued and sealed by Jordan M. Nehls, Registration Number PE- 8782, on 11/22/19 and the original document is stored at the North Dakota Department of Transportation

Existing Typical Sections

Chip Seal
ND Highway 14, From Wing N to Hwy 200

	STATE	PROJECT NO.	SECTION NO.	SHEET NO.
	ND	SS-1-014(008)021	30	2

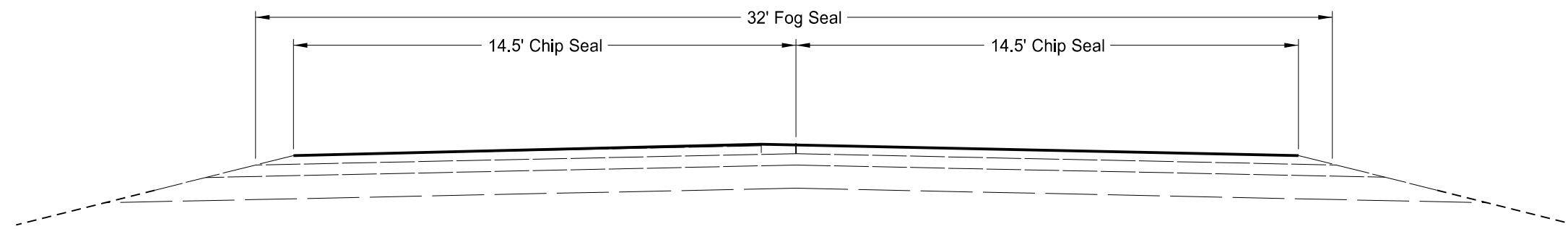

Proposed Typical Section
 RP 21.291 to RP 45.155
 RP 45.466 to RP 45.762

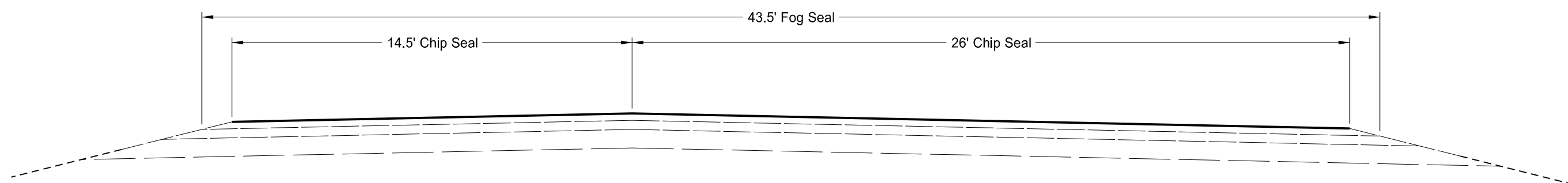

Proposed Typical Section (Climbing Lane)
 RP 45.155 to RP 45.466

This document was originally issued and sealed by Jordan M. Nehls, Registration Number PE- 8782, on 11/22/19 and the original document is stored at the North Dakota Department of Transportation

Proposed Typical Sections
 Chip Seal
 ND Highway 14, From Wing N to Hwy 200

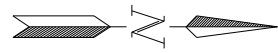

STATE	PROJECT NO.	SECTION NO.	SHEET NO.
ND	SS-1-014(008)021	100	2

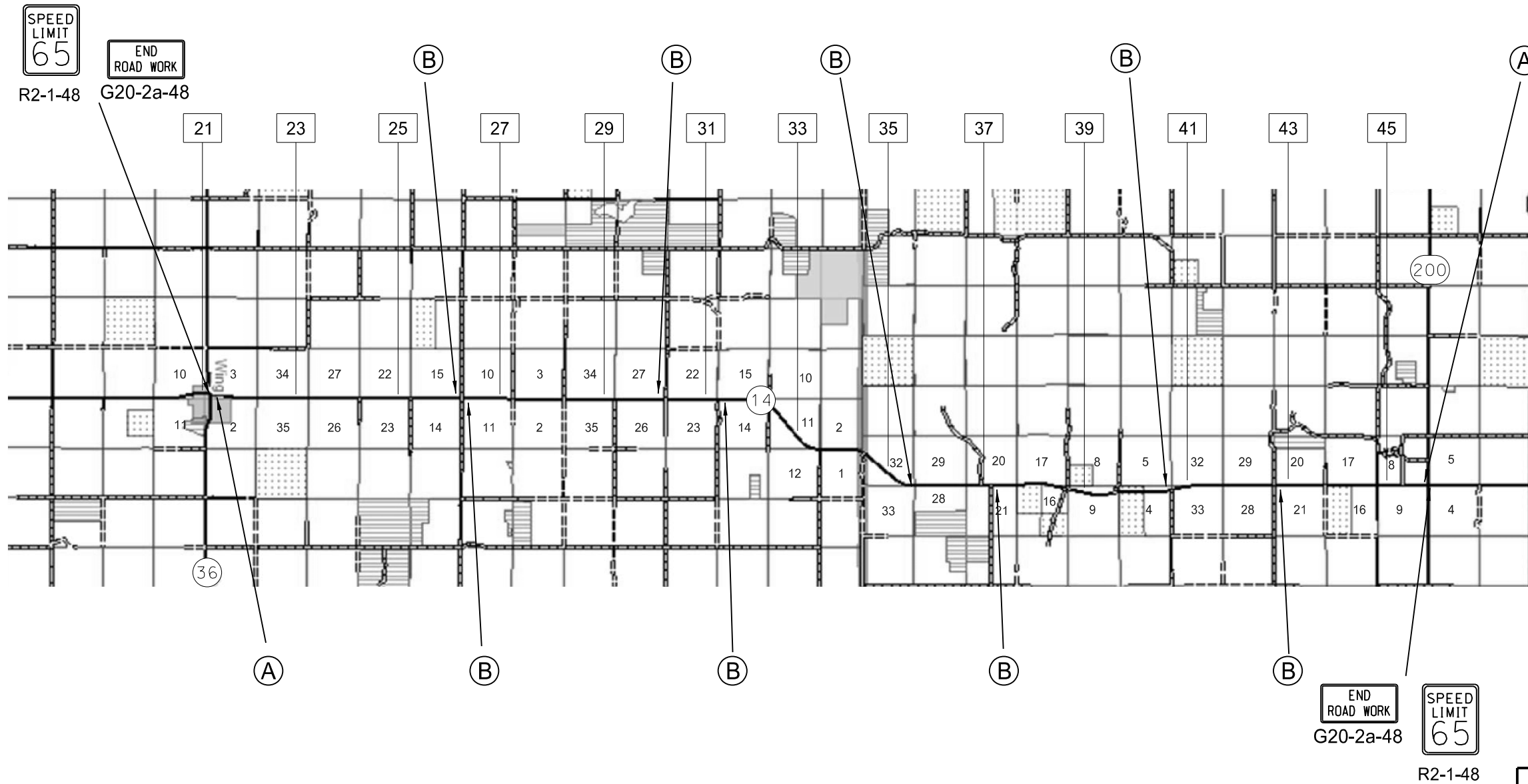

Sign Group A
 2 Locations

Sign Group B
 8 Locations

Place according to D-704-20 Note #6
 Skid Mount Sign

This document was originally issued and sealed by Jordan M. Nehls, Registration Number PE- 8782 , on 11/22/19 and the original document is stored at the North Dakota Department of Transportation

Work Zone Traffic Control

 Chip Seal
 Highway 14, From Wing N to Hwy 200

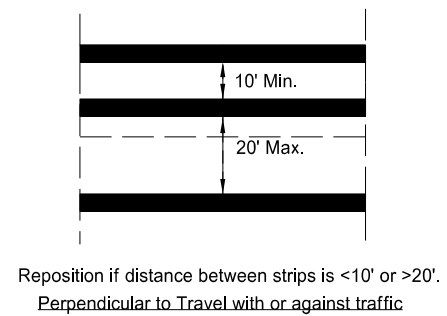
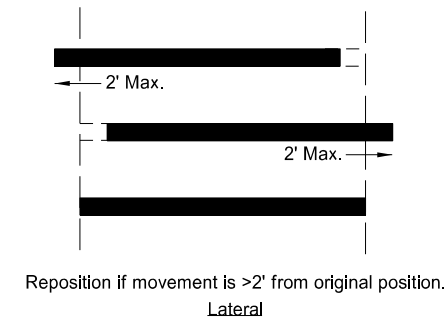
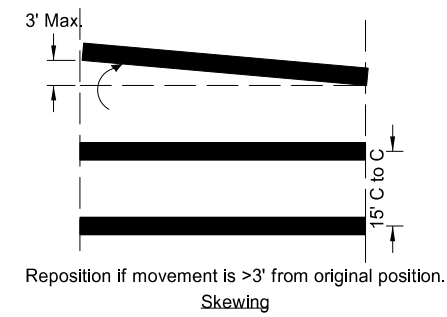
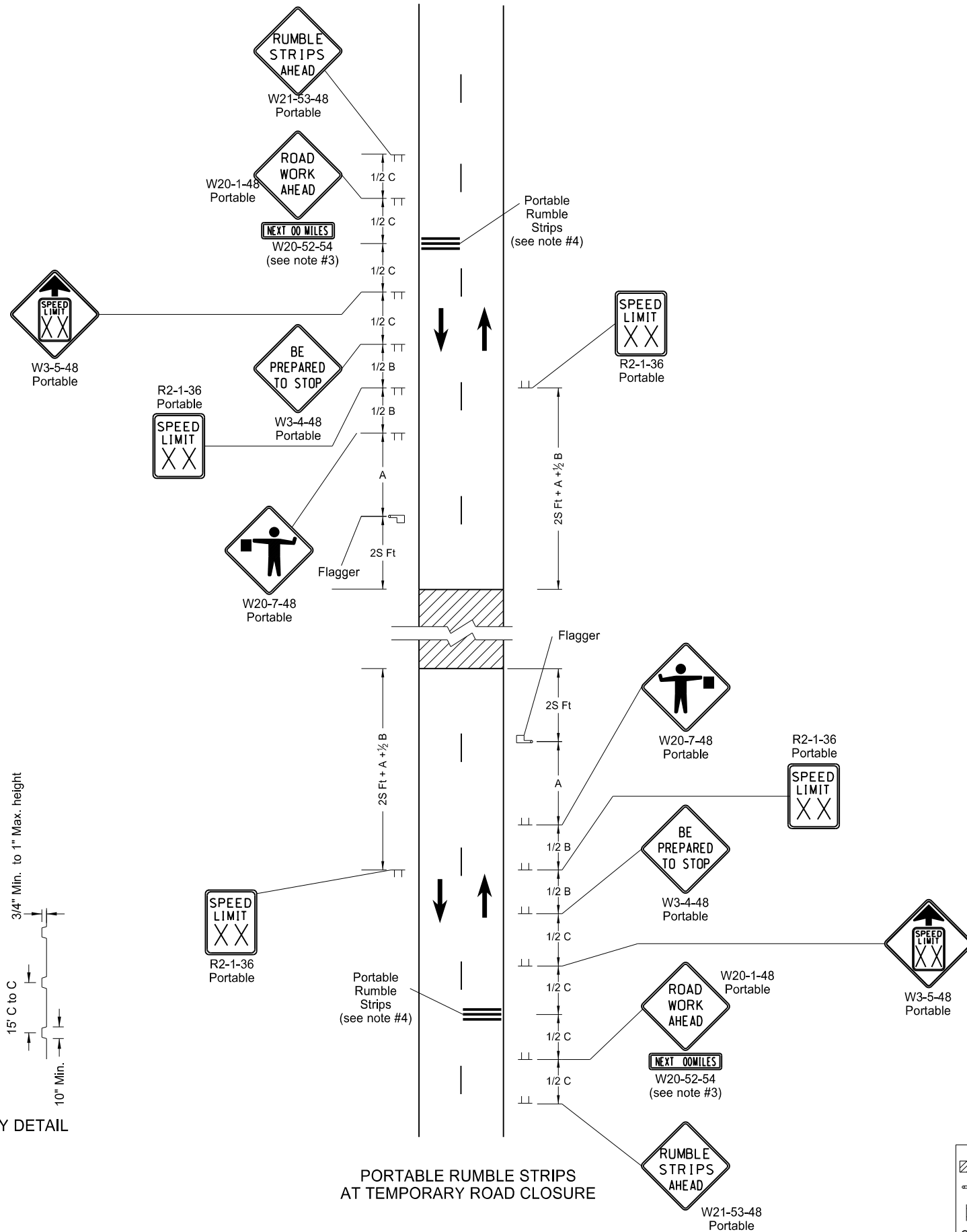

**PORTABLE RUMBLE STRIPS ARRAY
TYPES OF MOVEMENT AND MAXIMUM ALLOWANCES**

- Notes:
1. Number of devices were calculated using 40 mph. Speed determined in the field based on location and conditions.
 2. Re-establish the speed limit. Determine the exact speed limit in the field, dependent on location and conditions.
 3. Use sign W20-52-54 when work area is 1 mile or longer.
 4. Rumble strips are not used on a non paved surface or in a pre-construction speed zone of 25 mph or less.

Road Type	Distance Between Signs Min. (ft)		
	A	B	C
Urban - Low Speed (30 mph or less)	150	150	150
Urban - Low Speed (over 30 to 40 mph)	280	280	280
Urban - High Speed (over 40 mph to 50 mph)	360	360	360
Rural - High Speed (over 50 mph to 65 mph)	720	720	720

This document was originally issued and sealed by
Jordan M. Nehls,
 Registration Number
PE- 8782,
 on 11/22/19 and the original document is stored at the
 North Dakota Department
 of Transportation

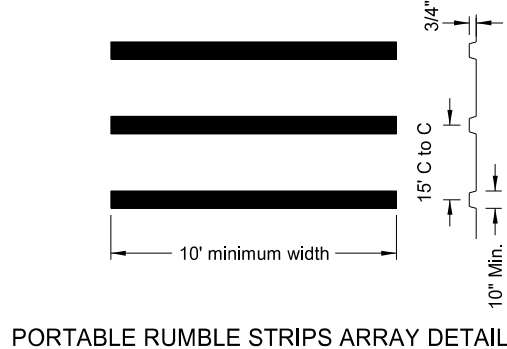

KEY

- Work area
- Flagger
- Sign
- S = Numerical value of speed limit or 85th percentile.

TWO-LANE PORTABLE RUMBLE STRIPS

Chip Seal
 Highway 14, From Wing N to Hwy 200

NDDOT ABBREVIATIONS

D-101-1

? This is a special text character used in the labeling of existing features. It indicates a feature that has an unknown characteristic, potentially based on: lack of description, location accuracy or purpose.

Abn abandoned
 Abut abutment
 Ac acres
 Adj adjusted
 Aggr aggregate
 Ahd ahead
 ARV air release valve
 Align alignment
 Al alley
 Alt alternate
 Alum aluminum
 ADA Americans with Disabilities Act
 A ampere
 & and
 Appr approach
 Approx approximate
 ACP asbestos cement pipe
 Asph asphalt
 AC asphalt cement
 Assmd assumed
 @ at
 Atten attenuation
 ATR automatic traffic recorder
 Ave Avenue
 Avg average
 ADT average daily traffic
 Az azimuth
 Bk back
 BF back face
 Bs backsight
 Balc balcony
 B Wire barbed wire
 Barr barricade
 Btry battery
 Brg bearing
 BI beehive inlet
 Beg begin
 BG below grade
 BM bench mark
 Bkwy bikeway
 Bit bituminous
 Blk block
 Bd Ft board feet
 BH bore hole
 BS both sides
 Bot bottom
 Blvd Boulevard
 Bndry boundary
 BC brass cap
 Brkwy breakaway
 Br bridge

Bldg building
 BV butterfly valve
 Byp bypass
 C Gdrl cable guardrail
 Calc calculate
 Cd candela
 CIP cast iron pipe
 CB catch basin
 CRS cationic rapid setting
 C Gd cattle guard
 C To C center to center
 Cl or C centerline
 Cm centimeter
 Ch chain
 Chnlk chain-link
 Ch Blk channel block
 Ch Ch channel change
 Chk check
 Chsld chiseled
 Cir circle
 Cl class
 Cl clay
 Cl F clay fill
 Cl Hvy clay heavy
 Cl Lm clay loam
 Clnt clean-out
 Clr clear
 Cl&gr clearing & grubbing
 Co S coal slack
 C Gr coarse gravel
 CS coarse sand
 Comb. combination
 Coml commercial
 Compr compression
 CADD computer aided drafting & design
 Conc concrete
 CECB concrete erosion control blanket
 Cond conductor
 Const construction
 Cont continuous
 CSB continuous split barrel sample
 Contr contraction
 Contr contractor
 CP control point
 Coord coordinate
 Cor corner
 Corr corrected
 CAES corrugated aluminum end section
 CAP corrugated aluminum pipe
 CMES corrugated metal end section
 CMP corrugated metal pipe
 CPVCP corrugated poly-vinyl chloride pipe
 CSES corrugated steel end section
 CSFES corrugated steel flared end section

CSP corrugated steel pipe
 CSTES corrugated steel traversable end section
 C coulomb
 Co County
 Crse course
 Ct Court
 Xarm cross arm
 Xbuck cross buck
 Xsec cross sections
 Xing crossing
 Xrd Crossroad
 Crn crown
 CF cubic feet
 M3 cubic meter
 M3/s cubic meters per second
 CY cubic yard
 Cy/mi cubic yards per mile
 Culv culvert
 C&G curb & gutter
 CI curb inlet
 CR curb ramp
 CS curve to spiral
 C cut
 Dd Ld dead load
 Defl deflection
 Defm deformed
 Deg or D degree
 DInt delineate
 DIntr delineator
 Depr depression
 Desc description
 Det detail
 DWP detectable warning panel
 Dtr detour
 Dia or \emptyset diameter
 Dir direction
 Dist distance
 DM disturbed material
 DB ditch block
 DG ditch grade
 Dbl double
 Dn down
 Dwg drawing
 Dr drive
 Drwy driveway
 DI drop inlet
 D dry density
 DSDS dynamic speed display sign
 Ea each
 Esmt easement
 E East
 EB Eastbound
 Elast elastomeric
 EL electric locker
 E Mtr electric meter
 Elec electric/al

EDM electronic distance meter
 Elev or El elevation
 Ellipt elliptical
 Emb embankment
 Emuls emulsion/emulsified
 ES end section
 Engr engineer
 ESS environmental sensor station
 Eq equal
 Eq equation
 Evgr evergreen
 Exc excavation
 Exst existing
 Exp expansion
 Expy Expressway
 E external of curve
 Extru extruded
 FOS factor of safety
 F Fahrenheit
 FS far side
 F farad
 Fed Federal
 FP feed point
 Ft feet/foot
 Fn fence
 Fn P fence post
 FO fiber optic
 FB field book
 FD field drive
 F fill
 FAA fine aggregate angularity
 FS fine sand
 FH fire hydrant
 Fl flange
 Flrd flared
 FES flared end section
 F Bcn flashing beacon
 FA flight auger sample
 FL flow line
 Ftg footing
 FM force main
 Fs foresight

NORTH DAKOTA DEPARTMENT OF TRANSPORTATION	
07-01-14	
REVISIONS	
DATE	CHANGE
04-23-18 09-20-18	General Revisions General Revisions

This document was originally issued and sealed by Roger Weigel, Registration Number PE-2930, on 09/20/18 and the original document is stored at the North Dakota Department of Transportation

NDDOT ABBREVIATIONS

D-101-2

Fnd	found	ID	inside diameter	Mkg	marking	PMT	pad mounted transformer
Fdn	foundation	Inst	instrument	MA	mast arm	Pg	pages
Frac	fractional	Intchg	interchange	Matl	material	Pntd	painted
Frwy	freeway	Intmdt	intermediate	Max	maximum	Pr	pair
Frt	front	Intscn	intersection	MC	meander corner	Pnl	panel
FF	front face	Inv	invert	Meas	measure	Pk	park
F Disp	fuel dispenser	IM	iron monument	Mdn	median	PK	Parker-Kalon nail
FFP	fuel filler pipes	I Pn	Iron Pin	MD	median drain	Pa	pascal
FLS	fuel leak sensor	IP	iron Pipe	MC	medium curing	PSD	passing sight distance
Furn	furnish/ed	Jt	joint	M	mega	Pvmt	pavement
Gal	gallon	J	joule	Mer	meridian	Ped	pedestal
Galv	galvanized	Jct	junction	M	meter	Ped	pedestrian
Gar	garage	K	kelvin	M/s	meters per second	PPP	pedestrian pushbutton post
Gs L	gas line	Kn	kilo newton	M	mid ordinate of curve	Pen.	penetration
G Reg	gas line regulator	Kpa	kilo pascal	MGS	Midwest Guardrail System	Perf	perforated
GMV	gas main valve	Kg	kilogram	Mi	mile	Per.	perimeter
G Mtr	gas meter	Kg/m3	kilogram per cubic meter	MM	mile marker	PL	pipeline
GSV	gas service valve	Km	kilometer	MP	mile post	PI	place
GVP	gas vent pipe	K	Kip(s)	MI	milliliter	P&P	plan & profile
GV	gate valve	LS	Land Surveyor (licensed)	Mm	millimeter	PL	plastic limit
Ga	gauge	LSIT	Land Surveyor In Training	Mm/hr	millimeters per hour	P Cap	plastic cap
Geod	geodetic	Ln	lane	Min	minimum	PI or P _L	plate
GIS	Geographical Information System	Lg	large	Misc	miscellaneous	Pt	point
G	giga	Lat	latitude	Mon	monument	PCC	point of compound curve
GPS	Global Positioning System	Lt	left	Mnd	mound	PC	point of curve
Gov	government	L	length of curve	Mtbl	mountable	PI	point of intersection
Grd	graded/grade	Lens	lenses	Mtd	mounted	PRC	point of reverse curvature
Gr	gravel	Lvl	level	Mtg	mounting	PT	point of tangent
Grnd	ground	LB	level book	Mk	muck	POC	point on curve
GWM	ground water monitor	Lving	leveling	Mun	municipal	POT	point on tangent
Gdrl	guardrail	Lht	light	N	nano	PE	polyethylene
Gtr	gutter	LP	light pole	NGS	National Geodetic Survey	PVC	polyvinyl chloride
H Plg	H piling	Ltg	lighting	NS	near side	PCC	Portland Cement concrete
Hdwl	headwall	Lig Co	lignite coal	Neop	neoprene	Lb or #	pounds
Ha	hectare	Lig Sl	lignite slack	Ntwk	network	PP	power pole
Ht	height	LF	linear foot	N	newton	Preempt	preemption
HI	height of instrument	Liq	liquid	N	North	Prefab	prefabricated
Hel	helical	LL	liquid limit	NE	North East	Prfmd or Pref	performed
H	henry	L	litre	NW	North West	Prep	preparation
Hz	hertz	Lm	loam	NB	Northbound	Press.	pressure
HDPE	high density polyethylene	Loc	location	No. or #	number		
HM	high mast	LC	long chord	Obsc	obscure(d)		
HP	high pressure	Long.	longitude	Obsn	observation		
HPS	high pressure sodium	Lp	loop	Ocpd	occupied		
Hwy	highway	LD	loop detector	Ocpy	occupy		
Hor	horizontal	Lm	lumen	Off Loc	office location		
HBP	hot bituminous pavement	Lum	luminaire	O/s	offset		
HMA	hot mix asphalt	L Sum	lump sum	OC	on center		
Hr	hour(s)	Lx	lux	C	one dimensional consolidation		
Hyd	hydrant	Mb	mailbox	OC	organic content		
Ph	hydrogen ion content	ML	main line	Orig	original		
Id	identification	M Hr	man hour	O To O	out to out		
In or "	inch	MH	manhole	OD	outside diameter		
Incl	inclinometer tube	Mkd	marked	OH	overhead		
IMH	inlet manhole	Mkr	marker				

NORTH DAKOTA DEPARTMENT OF TRANSPORTATION	
07-01-14	
REVISIONS	
DATE	CHANGE
08-03-15 04-23-18	General Revisions General Revisions

This document was originally issued and sealed by Roger Weigel, Registration Number PE-2930, on 04/23/18 and the original document is stored at the North Dakota Department of Transportation

NDDOT ABBREVIATIONS

PRV	pressure relief valve	Sc	scoria	St	street	Vert	vertical
Prestr	prestressed	Sec	seconds	SPP	structural plate pipe	VC	vertical curve
Pvt	private	Sec	section	SPPA	structural plate pipe arch	VCP	vitrified clay pipe
PD	private drive	SL	section line	Str	structure	V	volt
Prod.	production/produce	Sep	separation	Subd	subdivision	Vol	volume
Prog	programmed	Seq	sequence	Sub	subgrade	Wkwy	walkway
Prop.	property	Serv	service	Sub Prep	subgrade preparation	W	water content
Prop Ln	property line	Sh	shale	Ss	subsoil	WGV	water gate valve
Ppsd	proposed	Sht	sheet	SE	superelevation	WL	water line
PB	pull box	Shtng	sheeting	SS	supplement specification	WM	water main
Qty	quantity	Shldr	shoulder	Supp	supplemental	WMV	water main valve
Qtr	quarter	Sw or Sdwk	sidewalk	Surf	surfacing	W Mtr	water meter
Rad or R	radius	S	siemens	Surv	survey	WSV	water service valve
RR	railroad	SD	sight distance	Sym	symmetrical	WW	water well
Rlwy	railway	SN	sign number	SI	systems international	W	watt
Rsd	raised	Sig	signal	Tan	tangent	Wrng	wearing
RTP	random traverse point	Si Cl	silt clay	T	tangent (semi)	Wb	weber
Rge or R	range	Si Cl Lm	silty clay loam	TS	tangent to spiral	WIM	weigh in motion
RC	rapid curing	Si Lm	silty loam	Tel	telephone	W	west
Rec	record	Sgl	single	Tel B	Telephone Booth	WB	westbound
Rcy	recycle	SRCP	slotted reinforced concrete pipe	Tel P	telephone pole	Wrng	wiring
RAP	recycled asphalt pavement	SC	slow curing	Tv	television	W/	with
RPCC	recycled portland cement concrete	SS	slow setting	Temp	temperature	W/o	without
Ref	reference	Sm	small	Temp	temporary	WC	witness corner
R Mkr	reference marker	S	South	TBM	temporary bench mark	WGS	world geodetic system
RM	reference monument	SE	South East	T	tesla	Z	zenith
RP	reference point	SW	South West	T	thinwall tube sample		
Refl	reflectorized	SB	Southbound	T/mi	tons per mile		
RCB	reinforced concrete box	Sp	spaces	Ts	topsoil		
RCES	reinforced concrete end section	Spcl	special	Twp or T	township		
RCFES	reinforced concrete flared end section	SA	special assembly	Traf	traffic		
RCTES	reinforced concrete traversable end section	SP	special provisions	TSCB	traffic signal control box		
RCP	reinforced concrete pipe	G	specific gravity	Tr	trail		
RCPS	reinforced concrete pipe sewer	Spk	spike	Transf	transformer		
Reinf	reinforcement	SC	spiral to curve	TB	transit book		
Res	reservation	ST	spiral to tangent	Trans	transition		
Rs	residence	SB	split barrel sample	TT	transmission tower		
Ret	retaining	SH	sprinkler head	TES	traversable end section		
Rev	reverse	SV	sprinkler valve	Trans	transverse		
Rt	right	Sq	square	Trav	traverse		
R/W	right of way	SF	square feet	TP	traverse point		
Riv	river	Km2	square kilometer	Trtd	treated		
Rd	road	M2	square meter	Trmt	treatment		
Rdbd	road bed	SY	square yard	Qc	triaxial compression		
Rdwy	roadway	Stk	stake	TERO	tribal employment rights ordinance		
RWIS	roadway weather information system	Std	standard	Tpl	triple		
Rk	rock	N	standard penetration test	TP	turning point		
Rt	route	Std Specs	standard specifications	Typ	typical		
Salv	salvage(d)	Sta	station	Qu	unconfined compressive strength		
Sd	sand	Sta Yd	station yards	Ugrnd	underground		
Sdy Cl	sandy clay	Stm L	steam line	USC&G	US Coast & Geodetic Survey		
Sdy Cl Lm	sandy clay loam	SEC	steel encased concrete	USGS	US Geologic Survey		
Sdy Fl	sandy fill	SMA	stone matrix asphalt	Util	utility		
Sdy Lm	sandy loam	SSD	stopping sight distance	VG	valley gutter		
San	sanitary sewer line	SD	storm drain	Vap	vapor		

NORTH DAKOTA DEPARTMENT OF TRANSPORTATION	
07-01-14	
REVISIONS	
DATE	CHANGE
08-03-15 04-23-18	General Revisions General Revisions

This document was originally issued and sealed by Roger Weigel, Registration Number PE- 2930 , on 04/23/18 and the original document is stored at the North Dakota Department of Transportation

NDDOT UTILITY COMPANY AND ORGANIZATION ABBREVIATIONS

D-101-10

702COM 702 Communications
 ACCENT Accent Communications
 AGASSIZ WU Agassiz Water Users Incorporated
 AGC Associated General Contractors of America
 All PI Alliance Pipeline
 ALL SEAS WU All Seasons Water Users Association
 AMOCO PI Amoco Pipeline Company
 AMRDA HESS Amerada Hess Corporation
 AT&T AT&T Corporation
 B PAW Bear Paw Energy Incorporated
 BAKER ELEC Baker Electric
 BASIN ELEC Basin Electric Cooperative Incorporated
 BEK TEL Bek Communications Cooperative
 BELLE PL Belle Fourche Pipeline Company
 BLM Bureau of Land Management
 BNSF Burlington Northern Santa Fe Railway
 BOEING Boeing
 BRNS RWD Barnes Rural Water District
 BURK-DIV ELEC Burke-Divide Electric Cooperative
 BURL WU Burleigh Water Users
 Cable One Cable One
 CABLE SERV Cable Services
 CAP ELEC Capital Electric Cooperative Incorporat
 CASS CO ELEC Cass County Electric Cooperative
 CASS RWU Cass Rural Water Users Incorporated
 CAV ELEC Cavalier Rural Electric Cooperative
 CBLCOM Cablecom Of Fargo
 CENEX PL Cenex Pipeline
 CENT PL WATER DIST Central Pipe Line Water District
 CENT PWR ELEC Central Power Electric Cooperative
 COE Corps of Engineers
 CONS TEL Consolidated Telephone
 CONT RES Continental Resource Inc
 CPR Canadian Pacific Railway
 D O E Department Of Energy
 DAK CARR Dakota Carrier Network
 DAK CENT TEL Dakota Central Telephone
 DAK RWD Dakota Rural Water District
 DGC Dakota Gasification Company
 DICKEY R NET Dickey Rural Networks
 DICKEY RWU Dickey Rural Water Users Association
 DICKEY TEL Dickey Telephone
 DNRR Dakota Northern Railroad
 DOME PL Dome Pipeline Company
 DVELEC Dakota Valley Electric Cooperative
 DVMW Dakota, Missouri Valley & Western
 ENBRDG Enbridge Pipelines Incorporated
 ENVENTIS Enventis Telephone
 FALK MNG Falkirk Mining Company
 FHWA Federal Highway Administration
 G FKS-TRL WD Grand Forks-traill Water District
 GETTY TRD & TRAN Getty Trading & Transportation
 GLDN W ELEC Golden West Electric Cooperative
 GRGS CO TEL Griggs County Telephone
 GTR RAMSEY WD Greater Ramsey Water District

GT PLNS NAT GAS Great Plains Natural Gas Company
 HALS TEL Halstad Telephone Company
 IDEA1 Idea1
 INT-COMM TEL Inter-Community Telephone Company
 KANEB PL Kaneb Pipeline Company
 KEM ELEC Kem Electric Cooperative Incorporated
 KOCH GATH SYS Koch Gathering Systems Incorporated
 LKHD PL Lakehead Pipeline Company
 LNGDN RWU Langdon Rural Water Users Incorporated
 LWR YELL R ELEC Lower Yellowstone Rural Electric
 MCKNZ CON McKenzie Consolidated Telcom
 MCKENZIE ELEC McKenzie Electric Cooperative
 MCKNZ WRD McKenzie County Water Resource District
 MCLEOD McLeod USA
 MCLN ELEC McLean Electric Cooperative
 MCLN-SHRDN R WAT McLean-Sheridan Rural Water
 MDU Montana-dakota Utilities
 MID-CONT CABLE Mid-Continent Cable
 MIDSTATE TEL Midstate Telephone Company
 MINOT CABLE Minot Cable Television
 MINOT TEL Minot Telephone Company
 MISS VALL COMM Missouri Valley Communications
 MISS W W S Missouri West Water System
 MNKOTA PWR Minnkota Power
 MOR-GRAN-SOU ELEC Mor-gran-sou Electric Cooperative
 MOUNT-WILLI ELEC Mountrail-williams Electric Cooperative
 MRE LBTY TEL Moore & Liberty Telephone
 MUNICIPAL City Water And Sewer
 MUNICIPAL City Of '.....'
 N CENT ELEC North Central Electric Cooperative
 N VALL W DIST North Valley Water District
 ND PKS & REC North Dakota Parks And Recreation
 ND TEL North Dakota Telephone Company
 NDDOT North Dakota Department of Transportation
 NDSU SOIL SCI DEPT NDSU Soil Science Department
 NEMONT TEL Nemont Telephone
 NODAK R ELEC Nodak Rural Electric Cooperative
 NOON FRMS TEL Noonan Farmers Telephone Company
 NPR Northern Plains Railroad
 NSP Northern States Power
 NTH PRAIR RW Northern Prairie Rural Water Association
 NTHN BRDR PL Northern Border Pipeline
 NTHN PLNS ELEC Northern Plains Electric Cooperative Incorporated
 NTHWSTRN REF Northwestern Refinery Company
 NW COMM Northwest Communication Cooperation
 NWRWD Northwest Rural Water District
 ONEOK Oneok gas
 OSHA Occupational Safety and Health Administration
 OTTR TL PWR Otter Tail Power Company
 P L E M Prairielands Energy Marketing
 POLAR COM Polar Communications
 PVT ELEC Private Electric
 QWEST Qwest Communications
 R&T W SUPPLY R & T Water Supply Association

RED RIV TEL Red River Rural Telephone
 RESVTN TEL Reservation Telephone
 ROBRTS TEL Roberts Company Telephone
 R-RIDER ELEC Roughrider Electric Cooperative
 RRVW Red River Valley & Western Railroad
 S CENT REG WD South Central Regional Water District
 S E W U South East Water Users Incorporated
 SCOTT CABLE Scott Cable Television Dickinson
 SHERDN ELEC Sheridan Electric Cooperative
 SHEYN VLY ELEC Sheyenne Valley Electric Cooperative
 SKYTECH Skyland Technologies Incorporated
 SLOPE ELEC Slope Electric Cooperative Incorporated
 SOURIS RIV TELCOM Souris River Telecommunications
 ST WAT COMM State Water Commission
 STATE LN WATER State Line Water Cooperative
 STER ENG Sterling Energy
 STUT RWU Stutsman Rural Water Users
 SW PL PRJ Southwest Pipeline Project
 T M C Turtle Mountain Communications
 TCI TCI of North Dakota
 TESORO GHG PLNS PL Tesoro High Plains Pipeline
 TRI-CNTY WU Tri-County Water Users Incorporated
 TRL CO RWU Traill County Rural Water Users
 UNTD TEL United Telephone
 UPPR SOUR WUA Upper Souris Water Users Association
 US SPRINT U.S. Sprint
 USAF MSL CABLE U.S.A.F. Missile Cable
 USFWS US Fish and Wildlife Service
 USW COMM U.S. West Communications
 VRNDRY ELEC Verendrye Electric Cooperative
 W RIV TEL West River Telephone Incorporated
 WEB W. E. B. Water Development Association
 WILLI RWA Williams Rural Water Association
 WILSTN BAS PL Williston Basin Interstate Pipeline Company
 WLSH RWD Walsh Water Rural Water District
 WOLVRTN TEL Wolverton Telephone
 XLENER Xcel Energy
 YSVR Yellowstone Valley Railroad

NORTH DAKOTA DEPARTMENT OF TRANSPORTATION	
07-01-14	
REVISIONS	
DATE	CHANGE
04-23-18 09-20-18	General Revisions General Revisions

This document was originally issued and sealed by Roger Weigel, Registration Number PE-2930, on 09/20/18 and the original document is stored at the North Dakota Department of Transportation

Line Styles

Existing Topography

- Existing Ground Void
- Existing Cemetary Boundary
- Existing Box Culvert Bridge
- Existing Concrete Surface
- Existing Drainage Structure
- Existing Gravel Surface
- Existing Riprap
- Existing Dirt Surface
- Existing Asphalt Surface
- Existing Tie Point Line
- Existing Railroad Centerline
- Existing Guardrail Cable
- Existing Guardrail Metal
- Existing Edge of Water
- Existing Fence
- Existing Railroad
- Existing Field Line
- Exst Flow
- Existing Curb
- Existing Valley Gutter
- Existing Driveway Gutter
- Existing Curb and Gutter
- Existing Mountable Curb and Gutter

Proposed Topography

- Existing 3-Cable w Posts
- Site Boundary
- Existing Berm, Dike, Pit, or Earth Dam
- Existing Ditch Block
- Existing Tree Boundary
- Existing Brush or Shrub Boundary
- Existing Retaining Wall
- Existing Planter or Wall
- Existing W-Beam Guardrail with Posts
- Existing Railroad Switch
- Gravel Pit - Borrow Area
- Existing Wet Area-Vegetation Break
- 3-Cable w Posts
- Flow
- Fence
- Remove Line
- Wall
- Retaining Wall (Plan View)
- W-Beam w Posts

Existing Utilities

- Existing Electrical
- Existing Fiber Optic Line
- Existing TV Fiber Optic
- Existing Gas Pipe
- Existing Overhead Utility Line
- Existing Power
- Existing Fuel Pipeline
- Existing Undefined Above Ground Pipe Line
- Existing Sanitary Sewer
- Existing Sanitary Force Main
- Existing Storm Drain
- Existing Storm Drain Force Main
- Existing Culvert
- Existing Telephone Line
- Existing TV Line
- Existing Water or Steam Line
- Existing Under Drain
- Existing Slotted Drain
- Existing Conduit
- Existing Conductor
- Existing Down Guy Wire Down Guy
- Existing Underground Vault or Lift Station

Proposed Utilities

- 24 Inch Pipe
- Reinforced Concrete Pipe
- Under Drain
- Edge Drain

Traffic Utilities

- Conductor
- Fiber Optic
- Existing Loop Detector
- Existing Double Micro Loop Detector
- Micro Loop Detector Double
- Existing Micro Loop Detector
- Micro Loop Detector
- Signal Head with Mast Arm
- Existing Signal Head with Mast Arm

Sign Structures

- Existing Overhead Sign Structure
- Existing Overhead Sign Structure Cantilever
- Overhead Sign Structure Cantilever

NORTH DAKOTA DEPARTMENT OF TRANSPORTATION	
07-01-14	
REVISIONS	
DATE	CHANGE
09-23-16	Added and Revised Items, Organized by Functional Groups

This document was originally issued and sealed by Roger Weigel, Registration Number PE-2930, on 09/23/16 and the original document is stored at the North Dakota Department of Transportation

Line Styles

Right Of Way

- Easement
- Existing Easement
- Right of Way
- Existing Right of Way
- Existing Right of Way Railroad
- Existing Right of Way Not State Owned
- Existing Government Lot Line
- Existing Adjacent Block Lines
- Existing Adjacent Lot Lines
- Existing Adjacent Property Line
- Existing Adjacent Subdivision Lines
- Sight Distance Triangle Line
- Dimension Leader

Boundary Control

- Existing City Corporate Limits or Reservation Boundary
- Existing State or International Line
- Existing Township
- Existing County
- Existing Section Line
- Existing Quarter Section Line
- Existing Sixteenth Section Line
- Existing Centerline
- Tangent Line

Cross Sections and Typical

- Existing Ground
- Existing Topsoil (Cross Section View)
- Existing Ground Void (Not Surveyed)
- Existing Concrete
- Existing Aggregate (Cross Section View)
- Existing Curb and Gutter (Cross Section View)
- Existing Asphalt (Cross Section View)
- Existing Reinforcement Rebar

Geotechnical

- Geotextile Fabric Type D
- Geogrid
- Geotextile Fabric Type R
- Geotextile Fabric Type R1
- Geotextile Fabric Type RR
- Geotextile Fabric Type S
- Subgrade Reinforcement

Countours

- Depression Contours
- Supplemental Contour

Profile

- Subgrade, Subcut or Ditch Grade
- Topsoil Profile

Striping

- Centerline Pavement Marking
- Barrier with Centerline Pavement Marking
- Barrier Pavement Marking
- Stripe 4 IN Dotted Extension White
- Stripe 8 IN Dotted Extension White
- Stripe 8 IN Lane Drop

Pavement Joints

- Doweled Joint
- Tie Bar 30 Inch 4 Foot Center to Center
- Tie Bar 18 Inch 3 Foot Center to Center
- Tie Bar at Random Spacing

Bridge Details

- Hidden Object
- Small Hidden Object
- Large Hidden Object
- Phantom Object
- Centerline Main
- Centerline
- Existing Ground (Details)
- Existing Conditions
- Sheet Piling

Erosion Control

- Limits of Const Transition Line
- Bale Check
- Rock Check
- Floating Silt Curtain
- Silt Fence
- Excavation Limits
- Fiber Rolls

Environmental

- Wetland Mitigation
- Existing Wetland Easement USFWS
- Existing Wetland Jurisdictional
- Existing Wetland
- Tree Row

NORTH DAKOTA DEPARTMENT OF TRANSPORTATION	
07-01-14	
REVISIONS	
DATE	CHANGE
09-23-16	Added and Revised Items, Organized by Functional Groups

This document was originally issued and sealed by
Roger Weigel,
 Registration Number
PE-2930,
 on **09/23/16** and the original document is stored at the
 North Dakota Department
 of Transportation































Symbols

	North Arrow (Half Scale)		Attenuation Device		Existing Railroad Battery Box		Existing Delineator Type E
	Truck Mounted Attenuator		Diamond Grade Delineator Type A		Existing Bush or Shrub		Existing EFB Misc
	Type I Barricade		Diamond Grade Delineator Type B		Existing Gas Cap or Stub		Existing Flashing Beacon
	Type II Barricade		Diamond Grade Delineator Type C		Existing Sanitary Cap or Stub		Existing Pipe Mounted Flasher
	Type III Barricade		Diamond Grade Delineator Type D		Existing Storm Drain Cap or Stub		Existing Pad Mounted Feed Point
	Catch Basin		Diamond Grade Delineator Type E		Existing Water Cap or Stub		Existing Pipe Mounted Feed Point with Pad
	Cairn or Stone Circle		Flexible Delineator		Existing Sanitary Cleanout		Existing Pole Mounted Feed Point
	Video Detection Camera		Flexible Delineator Type A		Existing Concrete Foundation		Existing Railroad Frog
	Storm Drain Cap or Stub		Flexible Delineator Type B		Existing Traffic Signal Controller		Existing Snow Gate 18
	Corrugated Metal End Section 18 Inch		Flexible Delineator Type C		Existing Pad Mounted Signal Controller		Existing Snow Gate 28
	Corrugated Metal End Section 24 Inch		Flexible Delineator Type D		Existing Sixteenth Section Corner		Existing Snow Gate 40
	Corrugated Metal End Section 30 Inch		Flexible Delineator Type E		Existing Quarter Section Corner		Existing Headwall
	Corrugated Metal End Section 36 Inch		Delineator Type A		Existing Section Corner		Existing Pedestrian Head with Number
	Corrugated Metal End Section 42 Inch		Delineator Type A Reset		Existing Railroad Crossbuck		Existing Signal Head
	Corrugated Metal End Section 48 Inch		Delineator Type B		Existing Satellite Dish		Existing Sprinkler Head
	Concrete Foundation		Delineator Type B Reset		Existing Fuel Dispensers		Existing Fire Hydrant
	Ground Connection Conductor		Delineator Type C		Existing Flexible Delineator Type A		Existing Catch Basin Drop Inlet
	Neutral Connection Conductor		Delineator Type D		Existing Flexible Delineator Type B		Existing Curb Inlet
	Phase 1 Connection Conductor		Delineator Type E		Existing Flexible Delineator Type C		Existing Manhole Inlet
	Phase 2 Connection Conductor		Delineator Drums		Existing Flexible Delineator Type D		Existing Junction Box
	Traffic Cone		Spot Elevation		Existing Flexible Delineator Type E		
	Signal Controller		Existing Access Control Arrow		Existing Delineator Type A		
	Pad Mounted Signal Controller		Existing Artifact		Existing Delineator Type B		
	Alignment Data Point		Existing Flashing Beacon		Existing Delineator Type C		
	Emergency Vehicle Detector		Existing Benchmark		Existing Delineator Type D		

NORTH DAKOTA DEPARTMENT OF TRANSPORTATION	
07-01-14	
REVISIONS	
DATE	CHANGE

This document was originally issued and sealed by Roger Weigel, Registration Number PE-2930, on 07/01/14 and the original document is stored at the North Dakota Department of Transportation

Symbols





























































































	Existing Light Standard		Existing Manhole with Valve Water		Existing Telephone Pole		Existing Undefined Manhole
	Existing High Mast Light Standard 10 Luminaire		Existing Water Manhole		Existing Wood Pole		Existing Undefined Pull Box
	Existing High Mast Light Standard 3 Luminaire		Existing Mile Post Type A		Existing Post		Existing Undefined Pedestal
	Existing High Mast Light Standard 4 Luminaire		Existing Mile Post Type B		Existing Pedestrian Push Button Post		Existing Undefined Valve
	Existing High Mast Light Standard 5 Luminaire		Existing Mile Post Type C		Existing Control Point CP		Existing Undefined Pipe Vent
	Existing High Mast Light Standard 6 Luminaire		Existing Reference Marker		Existing Control Point GPS-RTK		Existing Gas Valve
	Existing High Mast Light Standard 7 Luminaire		Existing RW Marker		Existing Control Point TRI		Existing Water Valve
	Existing High Mast Light Standard 8 Luminaire		Existing Utility Marker		Existing Reference Marker Point NGS		Existing Fuel Pipe Vent
	Existing High Mast Light Standard 9 Luminaire		Iron Monument Found		Existing Pull Box		Existing Gas Pipe Vent
	Existing Overhead Sign Structure Load Center		Iron Pin R/W Monument		Existing Intelligent Transportation Pull Box		Existing Sanitary Pipe Vent
	Existing Luminaire		Existing Object Marker Type I		Existing Water Pump		Existing Storm Drain Pipe Vent
	Existing Light Standard Luminaire		Existing Object Marker Type II		Existing Slotted Reinforced Concrete Pipe		Existing Water Pipe Vent
	Existing Federal Mailbox		Existing Object Marker Type III		Existing RR Profile Spot		Existing Weather Station
	Existing Private Mailbox		Existing Electrical Pedestal		Existing Fuel Leak Sensors		Existing Ground Water Well Bore Hole
	Existing Meander Section Corner		Existing Telephone Pedestal		Existing Highway Sign		Existing Windmill or Tower
	Existing Meter		Existing Fiber Optic Telephone Pedestal		Existing Miscellaneous Spot		Existing Witness Corner
	Existing Electrical Manhole		Existing TV Pedestal		Existing Lighting Standard Pole		Flashing Beacon
	Existing Gas Manhole		Existing Fiber Optic TV Pedestal		Existing Traffic Signal Standard		Flagger
	Existing Sanitary Manhole		Existing Fuel Filler Pipes		Existing Transformer		Pipe Mounted Flasher
	Existing Sanitary Force Main Manhole		Existing Traverse PI Aerial Panel		Existing Large Evergreen Tree		Sanitary Force Main with Valve
	Existing Sanitary Manhole with Valve		Existing Pole		Existing Small Evergreen Tree		
	Existing Storm Drain Manhole		Existing Power Pole		Existing Large Tree		
	Existing Force Main Storm Drain Manhole		Existing Power Pole with Transformer		Existing Small Tree		
	Existing Force Main Storm Drain Manhole with Valve				Existing Tree Trunk		
	Existing Telephone Manhole				Existing Pad Mounted Traffic Signal Control Box		

NORTH DAKOTA DEPARTMENT OF TRANSPORTATION	
07-01-14	
REVISIONS	
DATE	CHANGE

This document was originally issued and sealed by Roger Weigel, Registration Number PE-2930, on 07/01/14 and the original document is stored at the North Dakota Department of Transportation

Symbols

D-101-32

 Pad Mounted Feed Point  Pipe Mounted Feed Point with Pad  Pole Mounted Feed Point  Headwall  Double Headwall with Vegetation Barrier  Single Headwall with Vegetation Barrier  Pole Mounted Head  Sprinkler Head  Fire Hydrant  Inlet Type 1  Inlet Type 2  Double Inlet Type 2  Inlet Grate Type 2  Junction Box  High Mast Light Standard 10 Luminaire  High Mast Light Standard 3 Luminaire  High Mast Light Standard 4 Luminaire  High Mast Light Standard 5 Luminaire  High Mast Light Standard 6 Luminaire  High Mast Light Standard 7 Luminaire  High Mast Light Standard 8 Luminaire  High Mast Light Standard 9 Luminaire  Relocate Light Standard  Overhead Sign Structure Load Center  Light Standard 100 Watt High Pressure Sodium Vapor Luminaire	 Light Standard 1000 Watt High Pressure Sodium Vapor Luminaire  Light Standard 150 Watt High Pressure Sodium Vapor Luminaire  Light Standard 175 Watt High Pressure Sodium Vapor Luminaire  Light Standard 200 Watt High Pressure Sodium Vapor Luminaire  Light Standard 250 Watt High Pressure Sodium Vapor Luminaire  Light Standard 310 Watt High Pressure Sodium Vapor Luminaire  Light Standard 35 Watt High Pressure Sodium Vapor Luminaire  Light Standard 400 Watt High Pressure Sodium Vapor Luminaire  Light Standard 50 Watt High Pressure Sodium Vapor Luminaire  Light Standard 70 Watt High Pressure Sodium Vapor Luminaire  Light Standard 700 Watt High Pressure Sodium Vapor Luminaire  Manhole  Manhole 48 Inch  Sanitary Force Main Manhole  Sanitary Sewer Manhole  Storm Drain Manhole  Storm Drain Manhole with Inlet  Reset Mile Post  Mile Post Type A  Mile Post Type B  Mile Post Type C  Right of Way Marker  Tubular Marker  Alignment Monument  Iron Pin Reference Monument	 Object Marker Type I  Object Marker Type II  Object Marker Type III  Caution Mode Arrow Panel  Back to Back Vertical Panel Sign  Double Direction Arrow Panel  Left Directional Arrow Panel  Right Directional Arrow Panel  Sequencing Arrow Panel  Truck Mounted Arrow Panel  Power Pole  Wood Pole  Pedestrian Push Button Post  Property Corner  Pull Box  Intelligent Transportation Pull Box  Sanitary Pump  Storm Drain Pump  Reinforced Pavement  Reinforced Concrete End Section 15 Inch  Reinforced Concrete End Section 18 Inch  Reinforced Concrete End Section 24 Inch  Reinforced Concrete End Section 30 Inch  Reinforced Concrete End Section 36 Inch  Reinforced Concrete End Section 42 Inch	 Reinforced Concrete End Section 48 Inch  Reinforced Concrete End Section 54 Inch  Reset Right of Way Marker  Reset USGS Marker  Right of Way Markers  Riser 30 Inch  Continuous Split Barrel Sample  Flight Auger Sample  Split Barrel Sample  Thinwall Tube Sample  Highway Sign  SNOW GATE 18 FT  SNOW GATE 28 FT  SNOW GATE 40 FT  Standard Penetration Test  Transformer  Inclinometer Tube  Underdrain Cleanout  Excavation Unit  Water Valve
--	--	---	--

NORTH DAKOTA DEPARTMENT OF TRANSPORTATION	
07-01-14	
REVISIONS	
DATE	CHANGE

This document was originally issued and sealed by
Roger Weigel,
 Registration Number
PE-2930,
 on 07/01/14 and the original document is stored at the
 North Dakota Department
 of Transportation

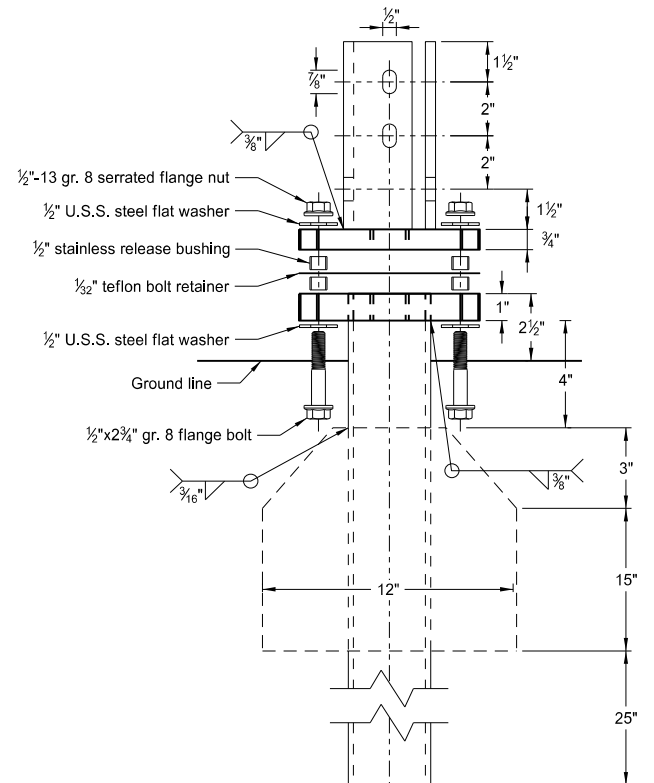

Multi-Directional Slip Base Assembly

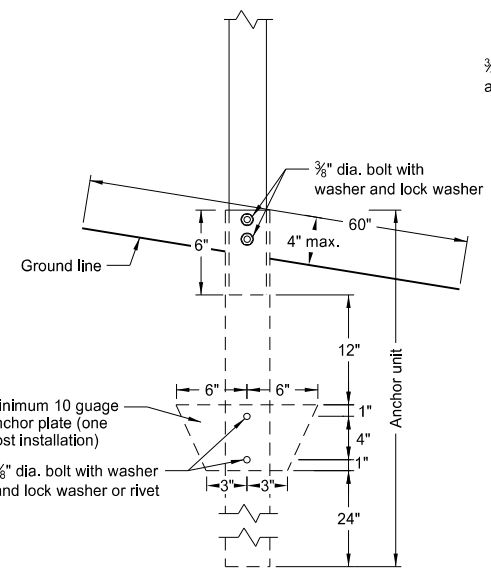

Anchor Unit and Post Assembly

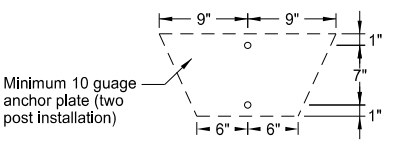

Minimum 10 gauge anchor plate (two post installation)

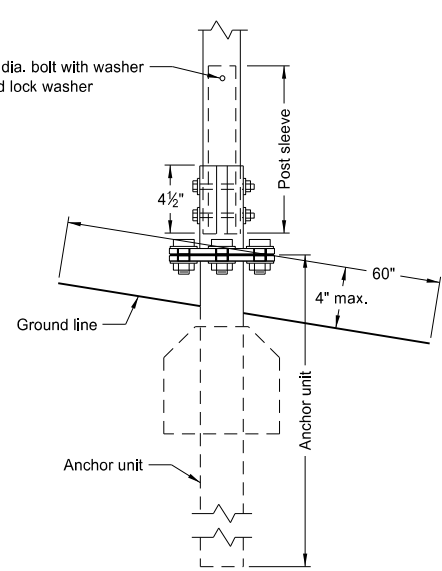

Multi-Directional Slip Base Anchor Unit and Post Sleeve Assembly

Perforated Tube

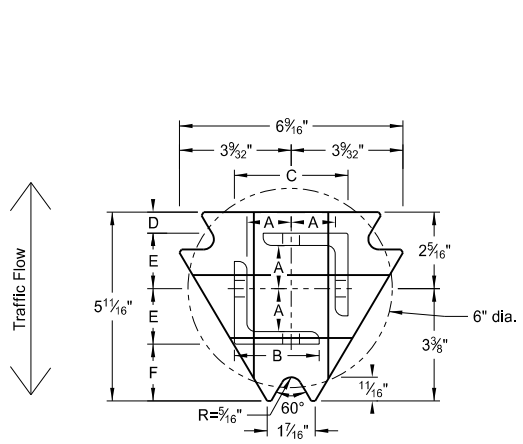

Top Post Receiver
Plate - ASTM A572 grade 50
Angle Receiver - 2 1/2" x 2 1/2" x 3/8" ASTM A36 structural angle

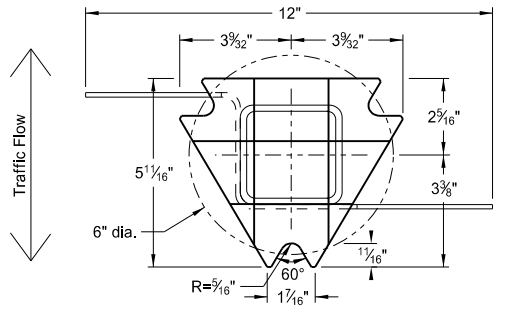

Bottom Soil Stub
Tube - 3"x3"x7 gauge ASTM A500 grade B tube
Stabilizing Wing - 7 gauge H.R.P.O. ASTM A1011
Plate - ASTM A572 grade 50

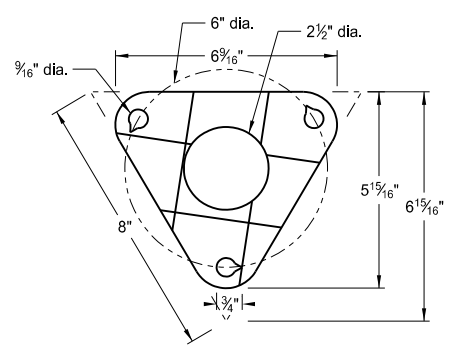

Bolt Retainer for Base Connection
Bolt Retainer - 1/2" Reprocessed Teflon

Notes:

1. Torque slip base bolts as specified by manufacturer.
2. Use anchor with 43.9 KSI yield strength and 59.3 KSI tensile strength.
3. Provide 4" vertical clearance for anchor or breakaway base. Measure the 4"x60" measurement above and below post location and back and ahead of post.
4. In concrete sidewalk, use same anchor without wings.
5. Provide more than 7" between the first and fourth posts of a four post sign.

Telescoping Perforated Tube						
Number of Posts	Post Size in.	Wall Thickness Gauge	Sleeve Size in.	Wall Thickness Gauge	Slip Base	Anchor Size without Slip Base in.
1	2	12			No	2 1/4
1	2 1/4	12			No	2 1/2
1	2 1/2	12			(A)	3
1	2 1/2	10			Yes	
1	2 1/4	12	2	12	Yes	
1	2 1/2	12	2 1/4	12	Yes	
2	2	12			No	2 1/4
2	2 1/4	12			No	2 1/2
2	2 1/2	12			Yes	
2	2 1/2	12			Yes	
2	2 1/4	10	2	12	Yes	
2	2 1/2	12	2 1/4	12	Yes	
3 & 4	2 1/2	12			Yes	
3 & 4	2 1/2	10			Yes	
3 & 4	2 1/2	12	2 1/4	12	Yes	
3 & 4	2 1/4	12	2	12	Yes	
3 & 4	2 1/2	10	2 3/16	10	Yes	

Properties of Telescoping Perforated Tube						
Tube Size in.	Wall Thickness in.	U.S. Standard Gauge	Weight per Foot lbs.	Moment of Inertia in. ⁴	Cross Sec. Area in. ²	Section Modulus in. ³
1 1/2 x 1 1/2	0.105	12	1.702	0.129	0.380	0.172
2 x 2	0.105	12	2.416	0.372	0.590	0.372
2 1/4 x 2 1/4	0.105	12	2.773	0.561	0.695	0.499
2 3/16 x 2 3/16	0.135	10	3.432	0.605	0.841	0.590
2 1/2 x 2 1/2	0.105	12	3.141	0.804	0.803	0.643
2 1/2 x 2 1/2	0.135	10	4.006	0.979	1.010	0.785

Top Post Receiver Data Table						
Square Post Sizes (B)	A	B	C	D	E	F
2 3/16" x 10 ga.	1 9/64"	2 1/2"	3 1/32"	2 5/32"	1 33/64"	1 1/8"
2 1/2" x 10 ga.	1 9/32"	2 1/2"	3 5/16"	5/8"	1 21/32"	1 3/4"

- (A) Use breakaway base when support is placed in weak soils. Engineer determines if soils are weak.
 (B) For additional wind load, insert the 2 3/16" x 10 ga. into 2 1/2" x 10 ga.

NORTH DAKOTA DEPARTMENT OF TRANSPORTATION	
2-28-14	
REVISIONS	
DATE	CHANGE
9-27-17	Updated to active voice
10-03-19	New Design Engr PE Stamp

This document was originally issued and sealed by
 Kirk J Hoff,
 Registration Number
 PE-4683,
 on 10/03/19 and the original document is stored at the
 North Dakota Department
 of Transportation

U-Channel Post

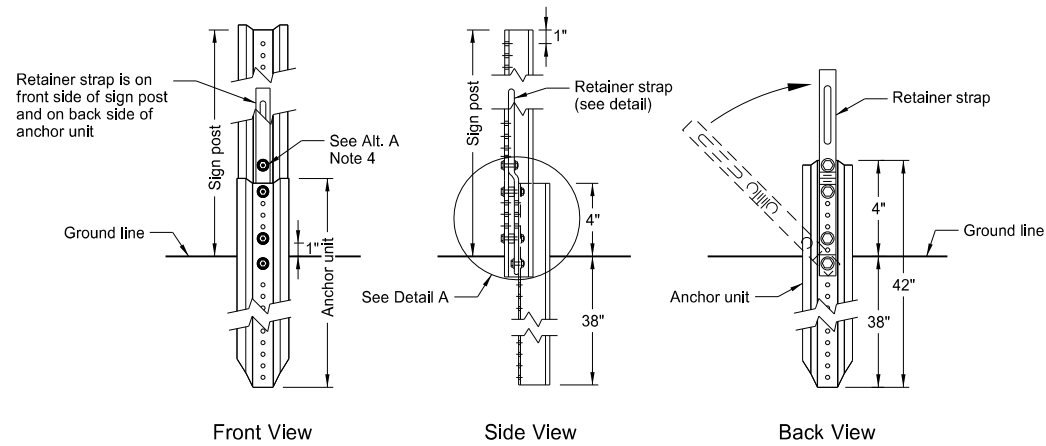
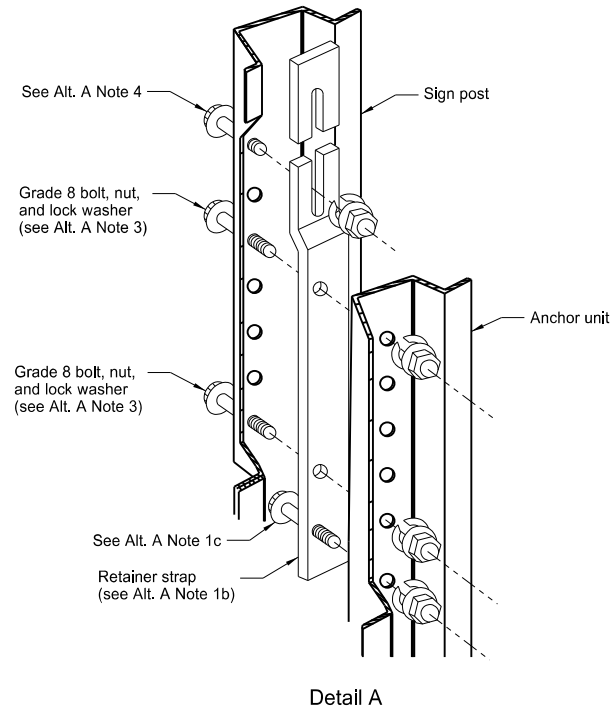

Breakaway U-Channel Detail Alternate A

Install a maximum of 2 posts within 7'.

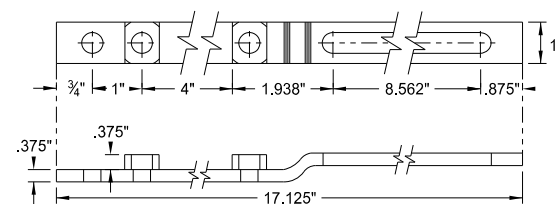

Retainer Strap Detail

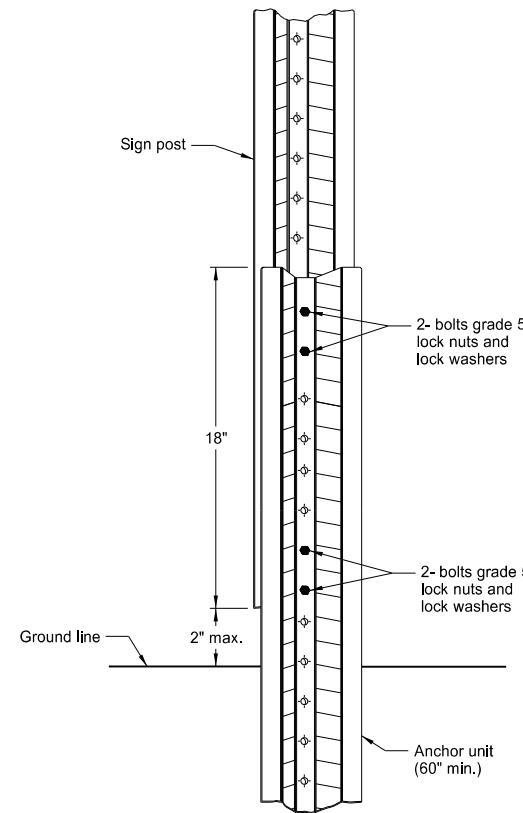

Breakaway U-Channel Splice Detail Alternate B (2.5 and 3 lb/ft)

Install a maximum of 3 posts within 7'.

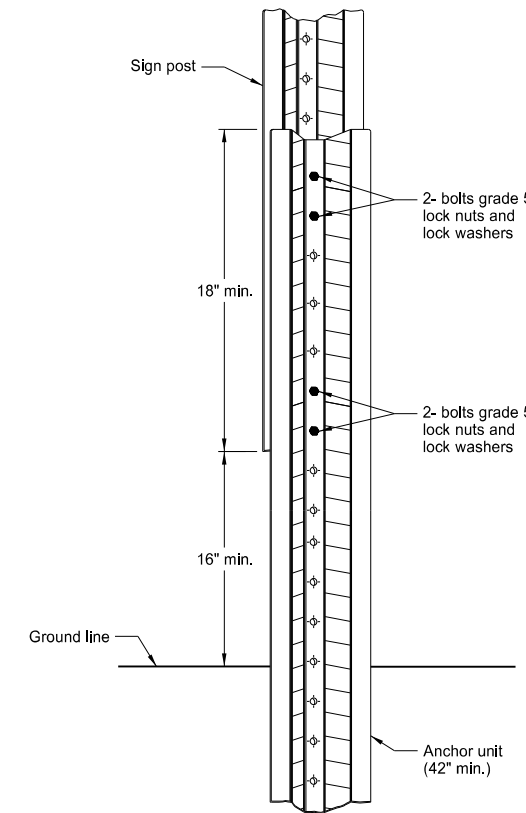

Breakaway U-Channel Splice Detail Alternate C (2.5 and 3 lb/ft)

Install a maximum of 3 posts within 7'.

Alternate A Steps of Installation:

1. a) Drive anchor unit to within 12" of ground level.
b) Establish proper assembly by lining up bottom hole of retainer strap with 6th hole from the top of the anchor unit.
c) Assemble strap to back of anchor unit using 5/16"x2" bolt, lock washer and nut.
d) Rotate strap 90° to left.
2. a) Drive anchor unit to 4" above ground.
b) Rotate strap to vertical position.
3. a) Place 5/16"x2" bolt, lock washer and nut in bottom of sign post to facilitate alignment of sign post with proper hole in anchor unit.
b) Alternately tighten two connector bolts.
4. Complete assembly by tightening 5/16"x2" bolt (this fastens sign post to retainer strap).
5. Properly nest base post, strap, and sign post. Proper nesting occurs when all flat surfaces of the base post, strap, and sign post at the bolts have full contact across the entire width.

NORTH DAKOTA DEPARTMENT OF TRANSPORTATION	
2-28-14	
REVISIONS	
DATE	CHANGE
9-27-17	Updated to active voice
10-03-19	New Design Engr PE Stamp

This document was originally issued and sealed by
 Kirk J Hoff,
 Registration Number
 PE-4683,
 on 10/03/19 and the original document is stored at the North Dakota Department of Transportation

CONSTRUCTION SIGN DETAILS
TERMINAL AND GUIDE SIGNS

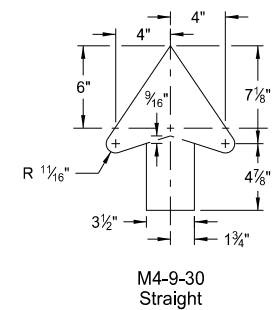
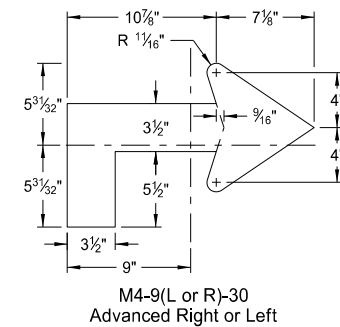
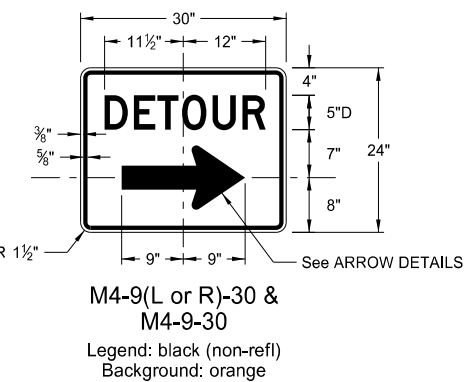
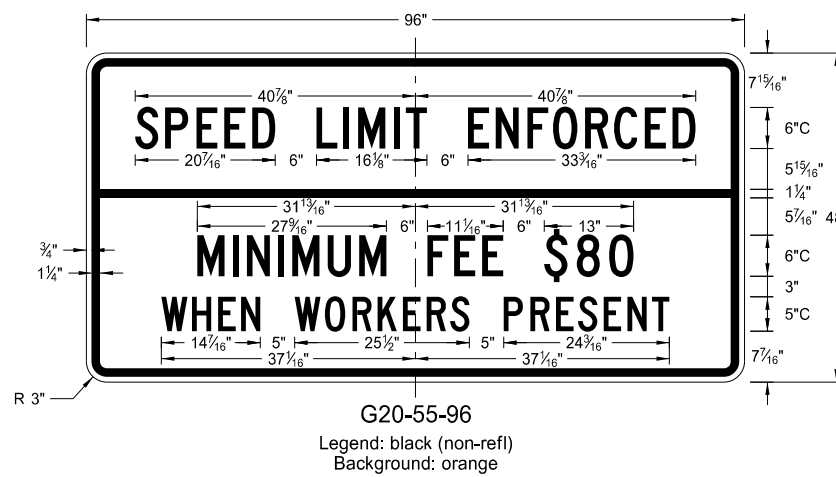
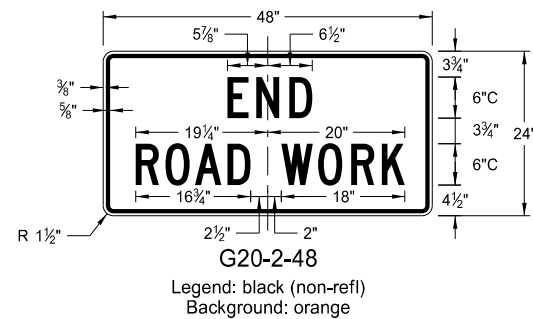
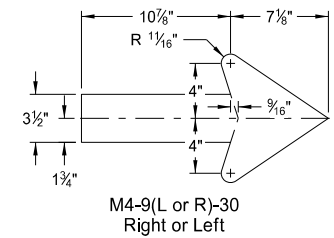
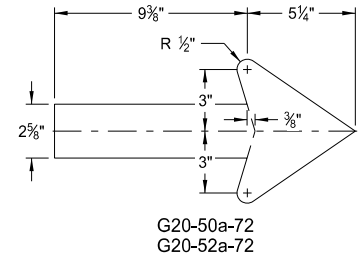
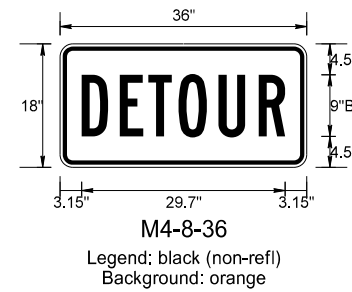
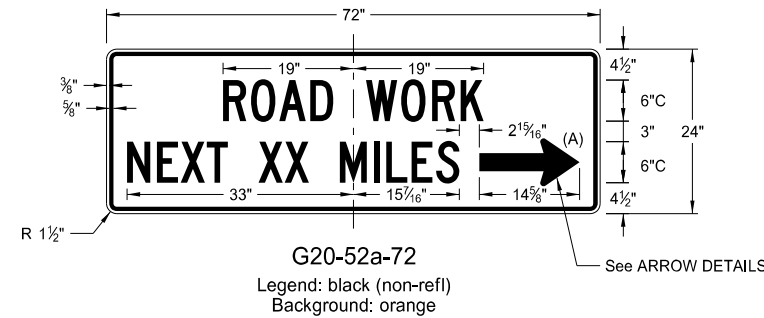
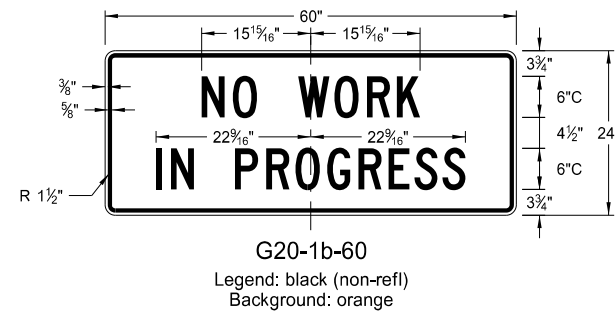
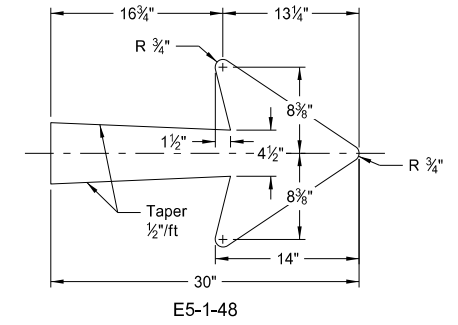
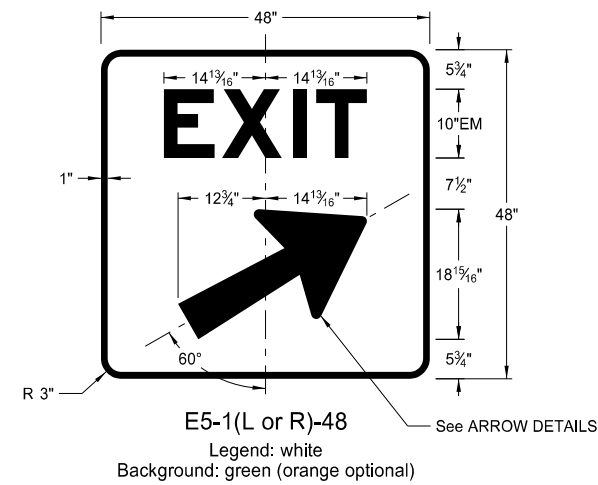
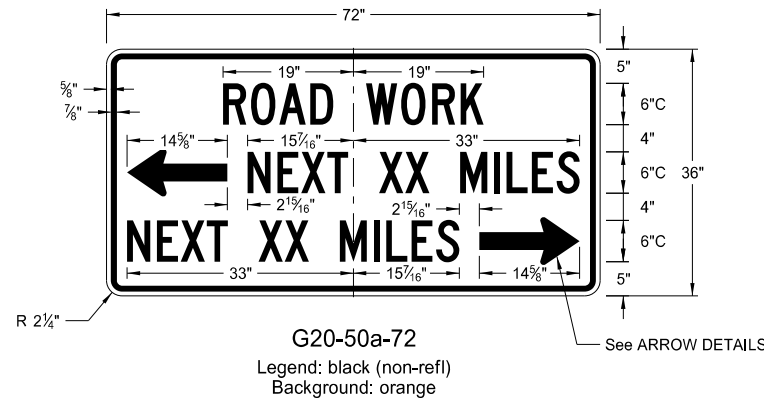
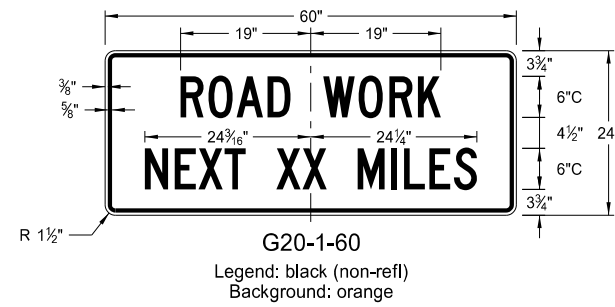

ARROW DETAILS

NOTES:

(A) Arrow may be right or left of the legend to indicate construction to the right or left.

NORTH DAKOTA DEPARTMENT OF TRANSPORTATION 8-13-13	
REVISIONS	
DATE	CHANGE
8-17-17 10-03-19	Added sign & background color New Design Engineer PE Stamp

This document was originally issued and sealed by
Kirk J Hoff,
Registration Number
PE-4683,
on 10/03/19 and the original document is stored at the North Dakota Department of Transportation

CONSTRUCTION SIGN DETAILS
REGULATORY SIGNS

D-704-10

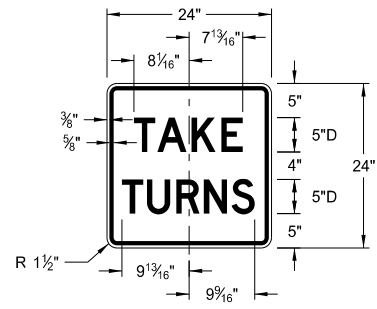

R1-50P-24
Legend: black (non-refl)
Background: white

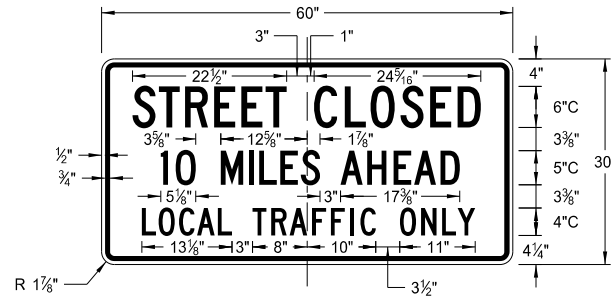

R11-3c-60
Legend: black (non-refl)
Background: white

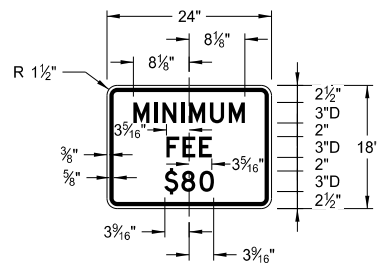

R2-1aP-24
Legend: black (non-refl)
Background: white

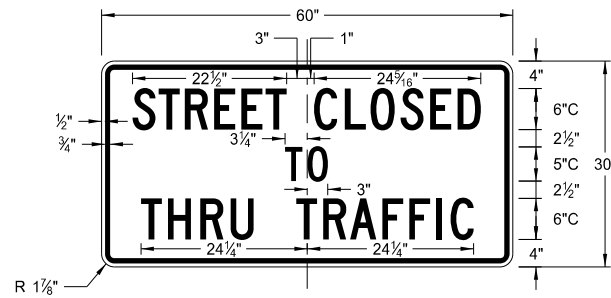

R11-4a-60
Legend: black (non-refl)
Background: white

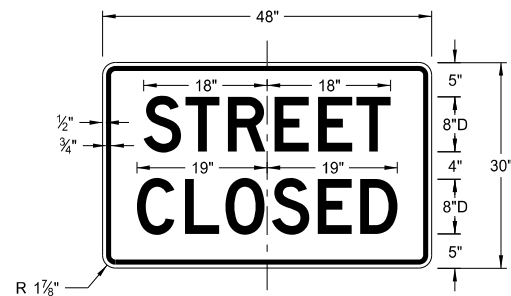

R11-2a-48
Legend: black (non-refl)
Background: white

NORTH DAKOTA DEPARTMENT OF TRANSPORTATION	
8-13-13	
REVISIONS	
DATE	CHANGE
8-17-17	Revised sign number
10-03-19	New Design Engineer PE Stamp

This document was originally issued and sealed by
Kirk J Hoff,
Registration Number
PE-4683,
on 10/03/19 and the original document is stored at the North Dakota Department of Transportation

CONSTRUCTION SIGN DETAILS
WARNING SIGNS

WORD	LETTER SPACING
AHEAD	Standard
200 FT	Standard
350 FT	Standard
500 FT	Standard
1000 FT	Reduce 40%
1500 FT	Reduce 40%
½ MILE	Reduce 50%
1 MILE	Standard

* DISTANCE MESSAGES

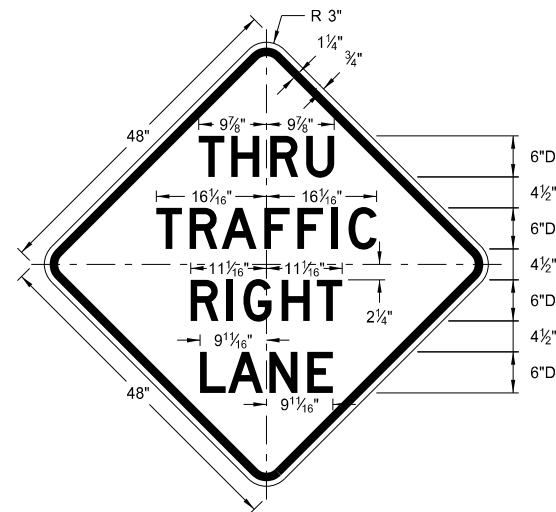

W5-8-48
Legend: black (non-refl)
Background: orange

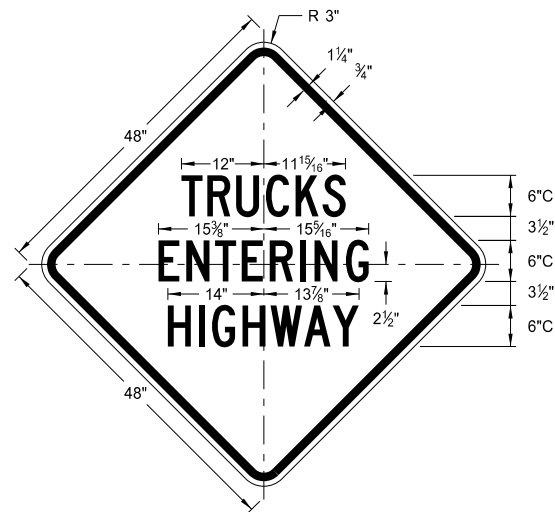

W8-53-48
Legend: black (non-refl)
Background: orange

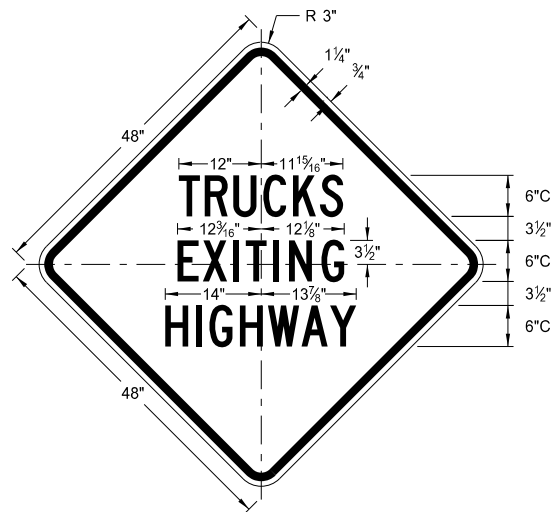

W8-56-48
Legend: black (non-refl)
Background: orange

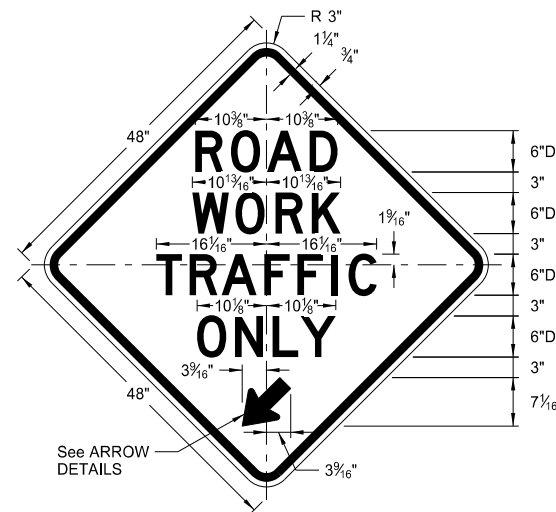

W5-9-48
Legend: black (non-refl)
Background: orange

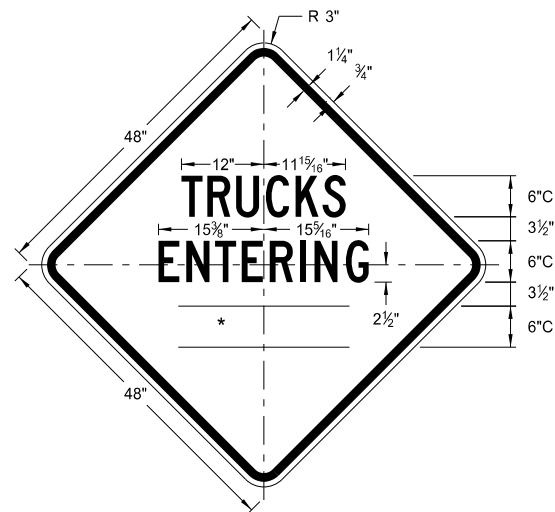

W8-54-48
Legend: black (non-refl)
Background: orange

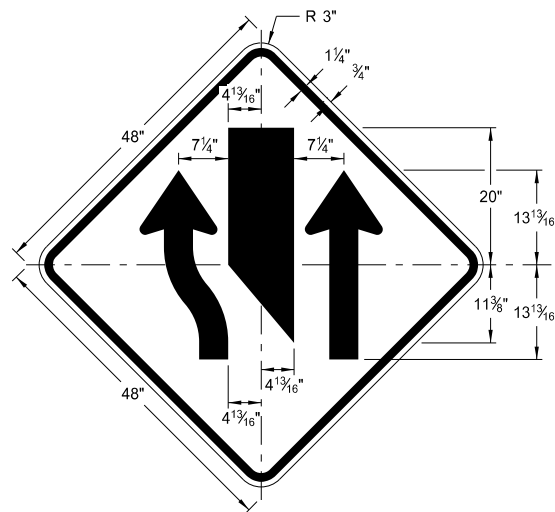

W9-3a-48
Legend: black (non-refl)
Background: orange

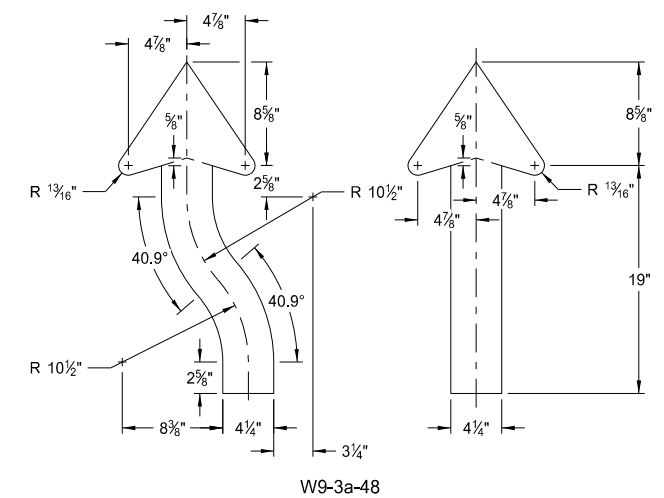
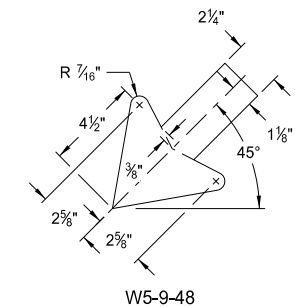

ARROW DETAILS

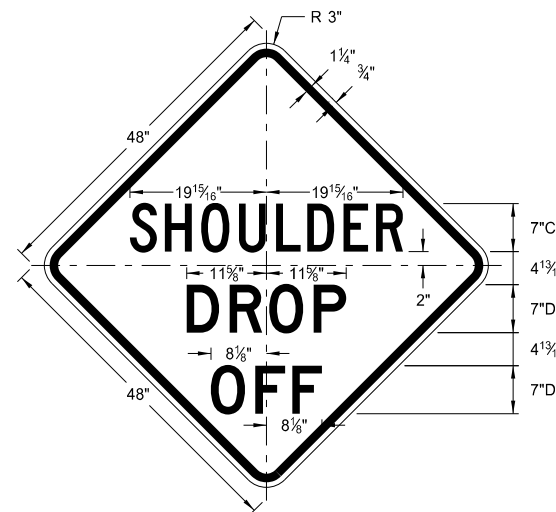

W8-9a-48
Legend: black (non-refl)
Background: orange

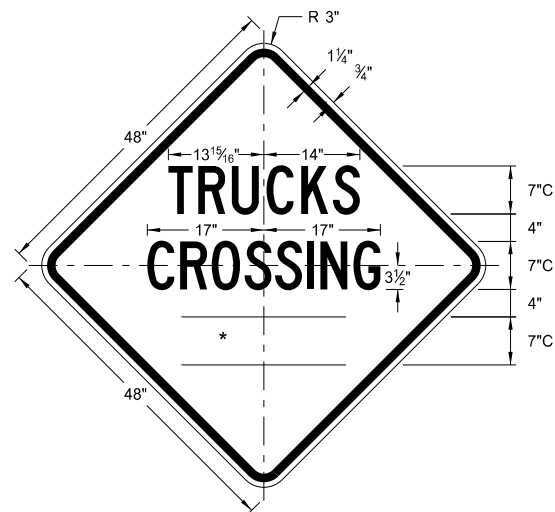

W8-55-48
Legend: black (non-refl)
Background: orange

NORTH DAKOTA DEPARTMENT OF TRANSPORTATION	
8-13-13	
REVISIONS	
DATE	CHANGE
8-17-17	Updated sign number
5-31-18	Revised sign and arrow details
10-03-19	New Design Engineer PE Stamp

This document was originally issued and sealed by
Kirk J Hoff,
Registration Number
PE- 4683,
on 10/03/19 and the original document is stored at the North Dakota Department of Transportation

CONSTRUCTION SIGN PUNCHING AND MOUNTING DETAILS

Note: In curb sections, place signs a minimum horizontal distance of 2' from face of the curb to near edge of the sign.

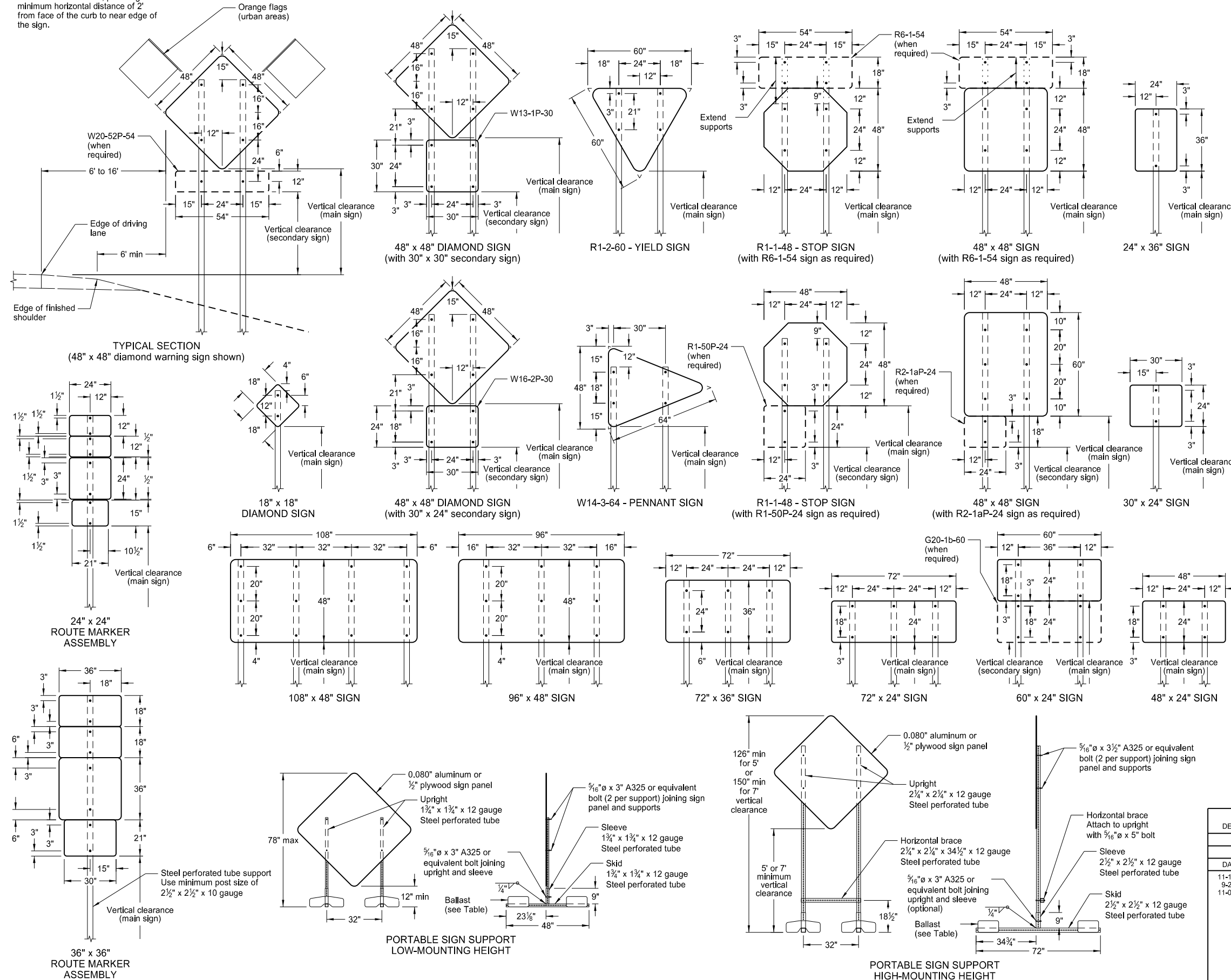

- NOTES:
1. Sign Supports: Galvanize or paint supports. Minimum post sizes are 2.5 lb/ft u-channel or 2" x 2" x 12 gauge steel perforated tube, except where noted. When installing signs on u-channel, minimum post size for assemblies containing a secondary sign is 3.0 lb/ft. Post sizes based on a wind speed of 55 MPH.
Place signs over 50 square feet on 2 1/2" x 2 1/2" perforated tube supports as a minimum.
Do not attach guy wires to sign supports. Attach wind beams behind sign panels when used with u-posts.
 2. Sign Panels: Provide sign panels made of 0.100" aluminum, 1/2" plywood, or other approved material, except where noted. Punch all holes round for 3/8" bolts.
 3. Alternate Messages: Install and remove alternate message signs on reflectorized plate (without borders) as required. (i.e. "Left" and "Right" message on lane closure sign)
 4. Route Marker Auxiliary Signs: Provide route marker auxiliary signs, such as the cardinal direction and directional arrows, with a background and legend that match the route marker they are used with:

Interstate - white legend on blue background
 Interstate Business Loop - white legend on green background
 US and State - black legend on white background
 County - yellow legend on blue background

5. Vertical Clearance: Install signs with a vertical clearance of 5'-0" (see TYPICAL SECTION.) In areas where parking or pedestrian movements are likely or the view of the sign may be obstructed, install signs with a vertical clearance of 7'-0" from the top of the curb or from the near edge of the driving lane in absence of a curb.

The vertical clearance to secondary signs is 1'-0" less than the vertical clearance stated above.

Provide a minimum clearance of 7'-0" from the ground at the post for signs with an area exceeding 50 square feet.

6. Portable Signs: Provide portable signs that meet the vertical clearance stated above when it is necessary to place signs within the pavement surface.

Use of low-mounting height (minimum 12" vertical clearance) portable signs for 5 days or less, is allowed as long as the view of the sign is not obstructed. Time delays caused by unforeseen circumstances, such as equipment breakdown, rain, subgrade failures, etc., will not accrue towards the 5 day period. Use of R9-8 through R9-11a series, W1-6 through W1-8 series, M4-10, and E5-1 is allowed for longer than 5 days.

Restrict signs mounted on portable sign supports shown in the LOW-MOUNTING HEIGHT and HIGH-MOUNTING HEIGHT details to a maximum surface area of 16 square feet.

MINIMUM BALLAST
(For each side of sign support base)

Sign Panel Mounting Height (ft)	Number of 25 lb sandbags for 4' x 4' sign panel
1'	6
5'	8
7'	10

Note: The number of sandbags are based on a wind speed of 55 MPH. Place sandbags at or near the ends of skids.

NORTH DAKOTA DEPARTMENT OF TRANSPORTATION	
10-4-13	
REVISIONS	
DATE	CHANGE

11-14-13	Revised Note 6
9-27-17	Updated to active voice
11-01-19	Revised 60"x24" sign detail

This document was originally issued and sealed by
 Kirk J Hoff,
 Registration Number
 PE-4683,
 on 11/1/19 and the original document is stored at the
 North Dakota Department
 of Transportation

ROAD CLOSURE LAYOUTS

Notes

1. Variables

S = Numerical value of speed limit or 85th percentile.
 W = The width of taper in feet.
 L = Minimum length of taper, S x W for freeways, expressways, and other roads with speeds of 45 mph or greater, or W x S²/60 for urban, residential, and other streets with speeds of 40 mph or less.

- Place barricades on moveable assemblies and signs on portable assemblies when located on roadway.
- Place delineator drums, barricades or cones for tapering traffic at dimension "S" and for tangents space at 2 times dimension "S".
- Place Sequencing Arrow Panels at the beginning of the taper when possible. Where shoulder width does not provide sufficient room, move the panel closer to the work area and place on roadway surface. See Shoulder Closure Standard Drawing. Use Type A on roadways with slow moving traffic speeds and low volume (25 mph or less and 750 ADT or less). Use Type B on roadways with moderate traffic speeds and volumes (40 mph or less and 5000 ADT or less). Use Type C on roadways with high traffic speeds and volumes (over 40 mph or over 5000 ADT).
- Re-establish speed. Determine exact speed limit in the field, dependent on location and conditions. Where speed reductions exceed 30 mph, install a second speed limit sign with the desired speed reduction (not to exceed 30 mph.) Place the second speed limit sign at 1/2 B.
- Install flags on warning signs in urban areas when signs are not portable. Mount 24 inch square flags perpendicular to the edges of the sign, and at such a distance above the edge that the flag does not touch the sign when limp.
- Cover existing speed limit signs within reduced speed zones.
- Where necessary, engineer will determine safe speed.
- As an option, use portable sign supports in lieu of post mounted signs in accordance with NDDOT Standard Drawing D-704-14.
- Sign G20-55-96 is not required if this standard is part of other traffic control, or the work is less than 15 days.
- Recommend using 40 mph speed limit in vicinity of workers, unless location and conditions dictate otherwise.

Road Type	Distance Between Signs Min. (ft)		
	A	B	C
Urban - Low Speed (30 mph or less)	150	150	150
Urban - Low Speed (over 30 to 40 mph)	280	280	280
Urban - High Speed (over 40 mph to 50 mph)	360	360	360
Rural - High Speed (over 50 mph to 65 mph)	720	720	720
Urban Expressway and Freeway (55 mph to 60 mph)	850	1350	2200
Rural Expressway and Freeway (70 mph to 75 mph)	1000	1500	2640
Interstate/4-Lane Divided (Maintenance and Surveying)	750	1000	1500

KEY

	Type III barricade		Work area
	Sign		Flagger
	Delineator drum		Sequencing arrow panel
	Tubular markers		Vertical panels back to back

Speed (mph)	Length Min (feet)
20	115
25	155
30	200
35	250
40	305
45	360
50	425
55	495
60	570
65	645
70	730
75	820

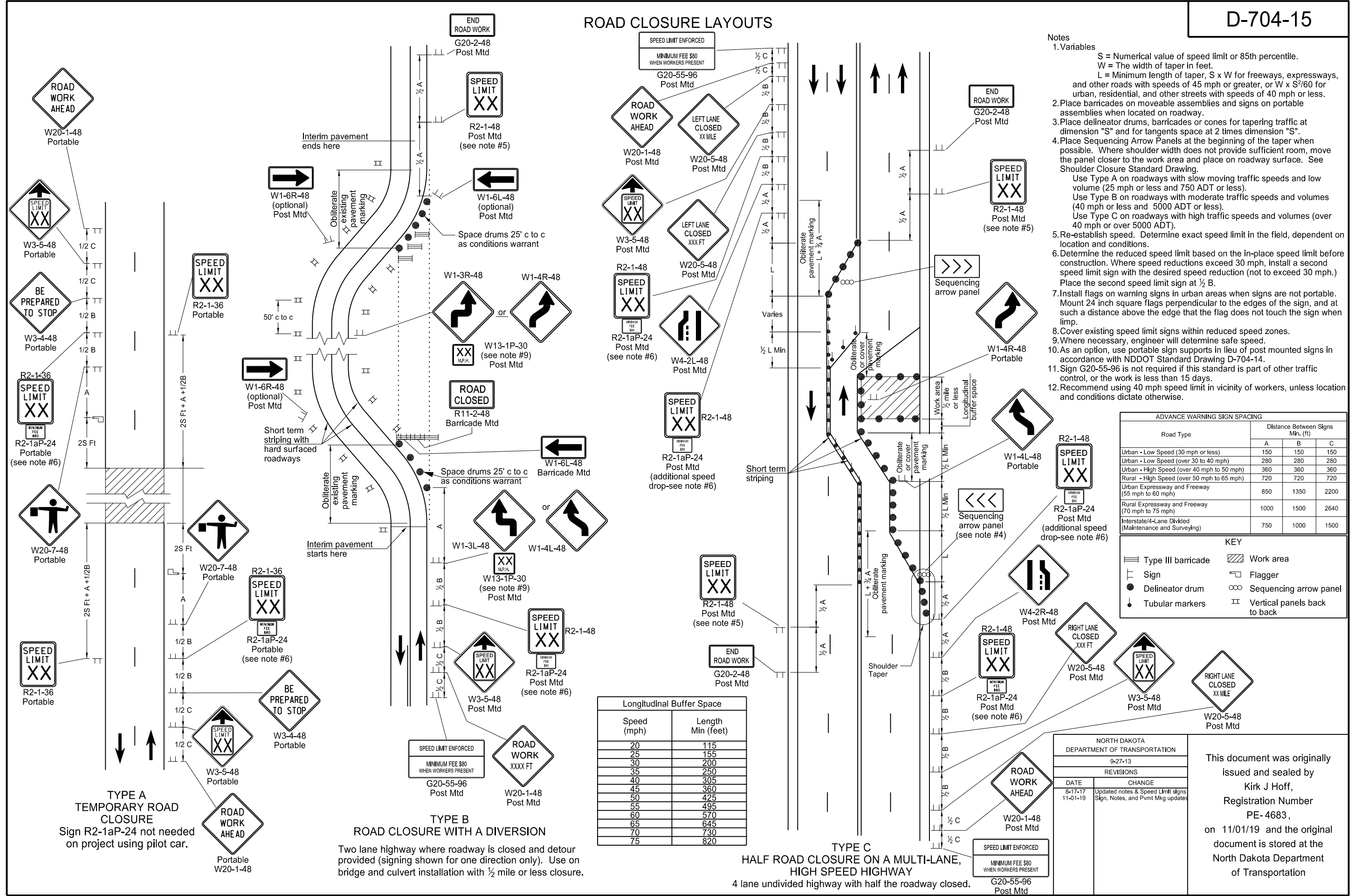

TYPE A
TEMPORARY ROAD CLOSURE
 Sign R2-1aP-24 not needed on project using pilot car.

TYPE B
ROAD CLOSURE WITH A DIVERSION
 Two lane highway where roadway is closed and detour provided (signing shown for one direction only). Use on bridge and culvert installation with 1/2 mile or less closure.

TYPE C
HALF ROAD CLOSURE ON A MULTI-LANE, HIGH SPEED HIGHWAY
 4 lane undivided highway with half the roadway closed.

NORTH DAKOTA DEPARTMENT OF TRANSPORTATION	
9-27-13	
REVISIONS	
DATE	CHANGE
8-17-17	Updated notes & Speed Limit signs
11-01-19	Sign, Notes, and Pvmnt Mtg updated

This document was originally issued and sealed by
 Kirk J Hoff,
 Registration Number
 PE-4683,
 on 11/01/19 and the original document is stored at the
 North Dakota Department
 of Transportation

TERMINAL AND SEAL COAT SIGN LAYOUTS

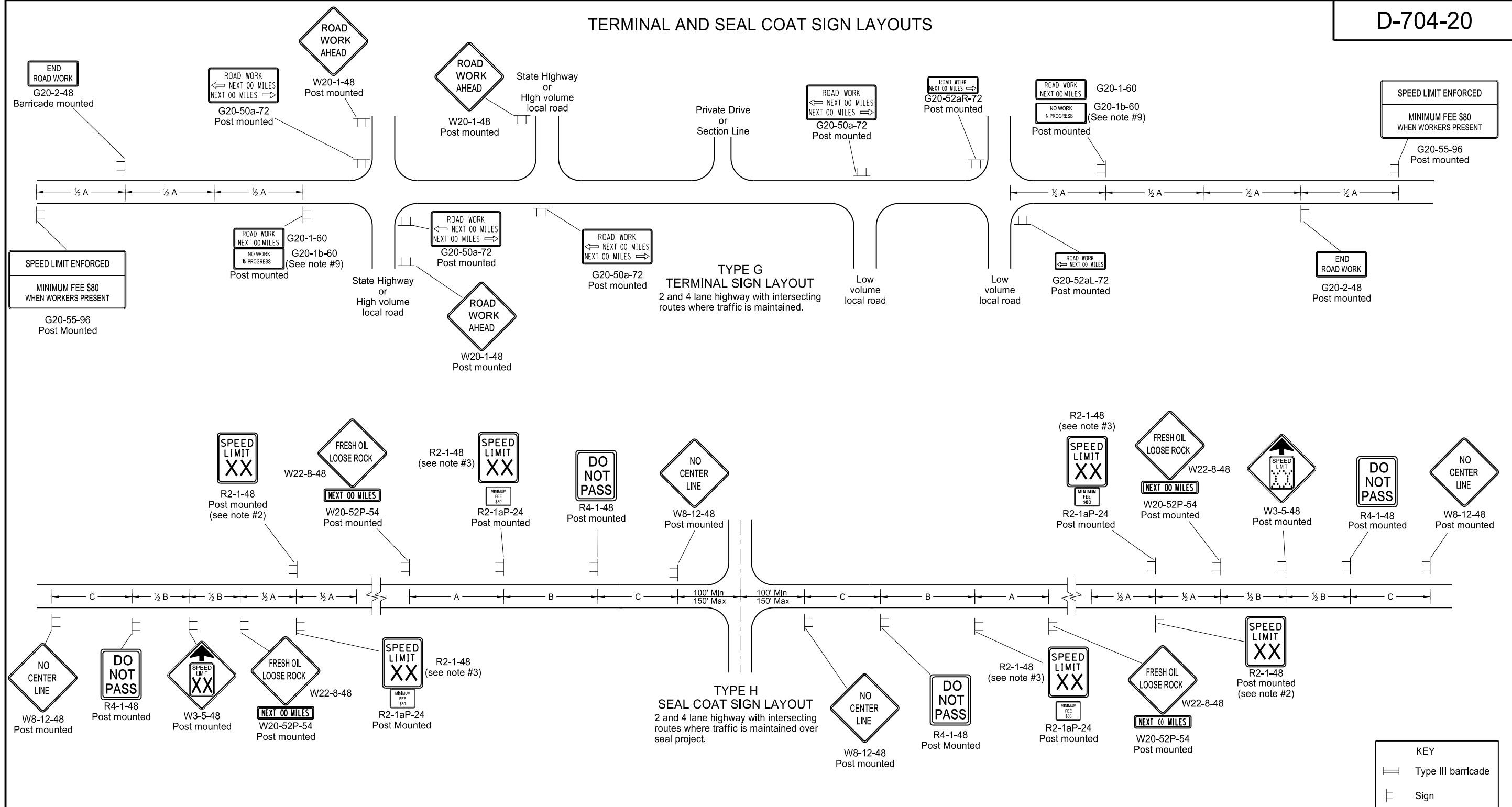

- Place barricades on moveable assemblies and signs on portable assemblies when located on roadway.
- Determine the exact speed limit in the field, based on location and conditions.
- Determine the reduced speed limit based on the in place speed limit before construction. Where speed limit reductions exceed 30 MPH, install a second speed limit sign with the desired speed reduction (not to exceed 30 MPH.) Place the second speed limit sign at 1/2 B.
- Install flags on warning signs in urban areas when signs are not portable. Mount 24 inch square flags perpendicular to the edges of the sign, and at such a distance above the edge that the flag does not touch the sign when limp.
- Cover existing speed limit signs within a reduced speed zone.
- On seal coat projects, place signs R2-1-48, R2-1aP-24, R4-1-48, W22-8-48 and W20-52P-54 after all important intersections and at five mile intervals. Place sign W8-12-48 after all important intersections and at 2 mile intervals until short term center line pavement marking is placed.
- As an option, use portable sign supports in lieu of post mounted signs in accordance with the NDDOT Standard Drawing D-704-14.
- Cover or remove speed limit signs from layout Type H when loose aggregate is removed.
- Install sign G20-1b-60 when work is suspended for winter.
- Use other traffic control layouts in immediate work areas. Place sign R2-1aP-24 below speed limit signs in reduced speed limit work areas.
- Sign G20-55-96 is not required if work is less than 15 days.
- Recommend using 40 mph speed limit in vicinity of workers, unless location and conditions dictate otherwise.

Road Type	Distance Between Signs Min. (ft)		
	A	B	C
Urban - Low Speed (30 mph or less)	150	150	150
Urban - Low Speed (over 30 to 40 mph)	280	280	280
Urban - High Speed (over 40 mph to 50 mph)	360	360	360
Rural - High Speed (over 50 mph to 65 mph)	720	720	720
Urban Expressway and Freeway (55 mph to 60 mph)	850	1350	2200
Rural Expressway and Freeway (70 mph to 75 mph)	1000	1500	2640
Interstate/4-Lane Divided (Maintenance and Surveying)	750	1000	1500

NORTH DAKOTA DEPARTMENT OF TRANSPORTATION	
9-27-13	
REVISIONS	
DATE	CHANGE
8-17-17	Updated notes & sign numbers.
11-01-19	Note & sign updates.

This document was originally issued and sealed by
 Kirk J Hoff,
 Registration Number
 PE- 4683,
 on 11/1/19 and the original document is stored at the
 North Dakota Department
 of Transportation

MISCELLANEOUS SIGN LAYOUTS

D-704-26

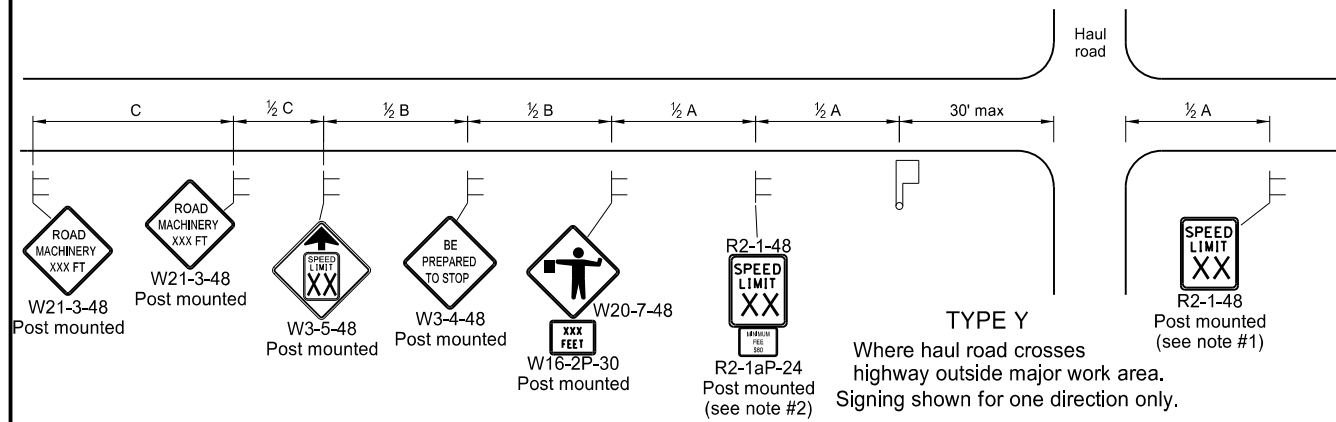

TYPE Y
Where haul road crosses highway outside major work area. Signing shown for one direction only.

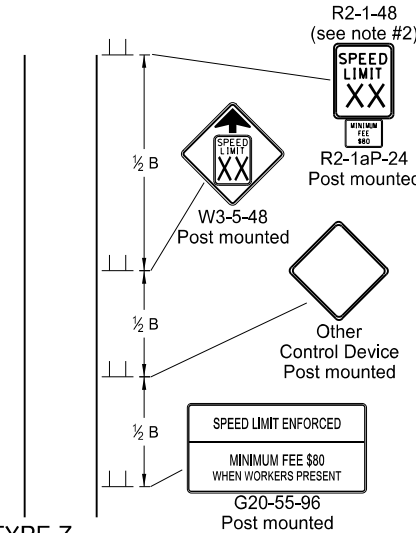

TYPE Z
Where speed zone is needed. Signing shown for one direction only.

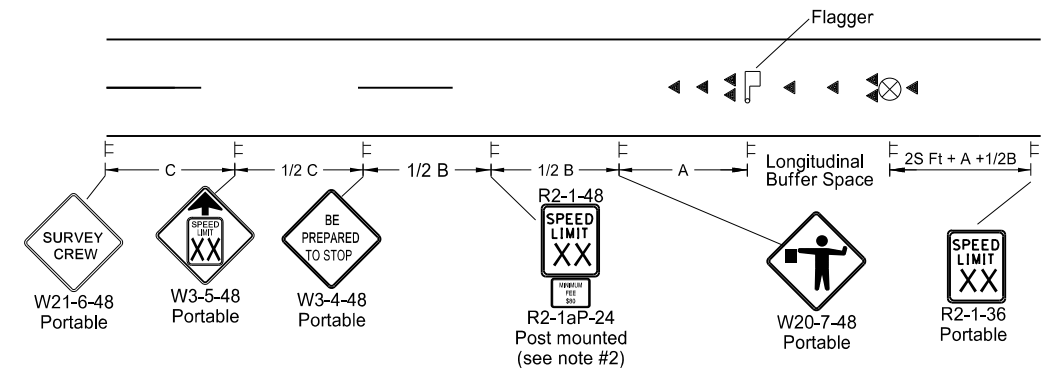

TYPE AA
Where survey crew is used. Signing shown for one direction only.

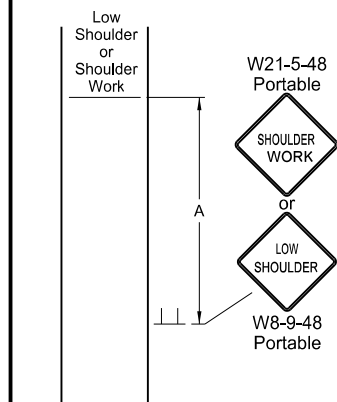

TYPE BB
Within major work area where sign conditions exist

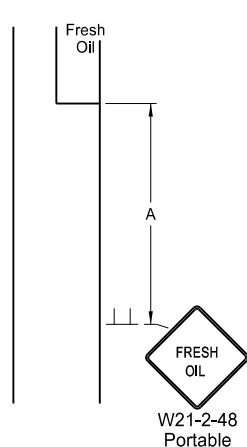

TYPE CC
Where sign conditions exist

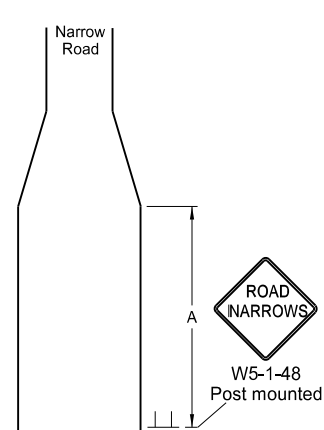

TYPE DD
Where sign conditions exist

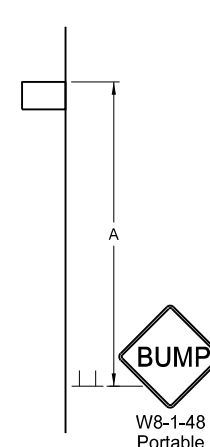

TYPE EE
Where sign conditions exist

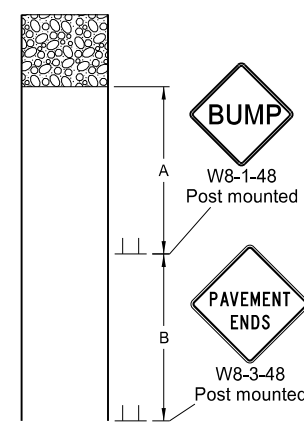

TYPE FF
Where sign conditions exist. Signing shown for one direction only.

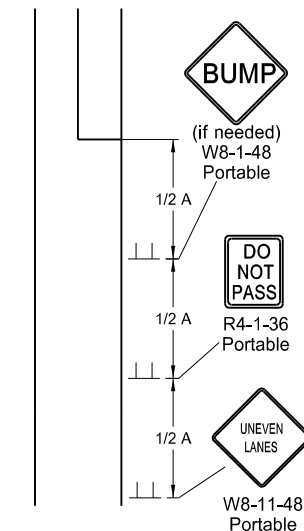

TYPE GG
Where elevation difference exists between lanes

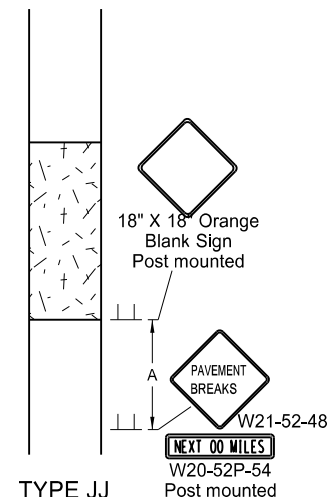

TYPE JJ
For break in pavement. Install signs when conditions exist and remove when not applicable. Signing shown for one direction only.

KEY

	Flagger		Sign
	Cones		Survey Equipment

S = Numerical value of speed limit or 85th percentile.

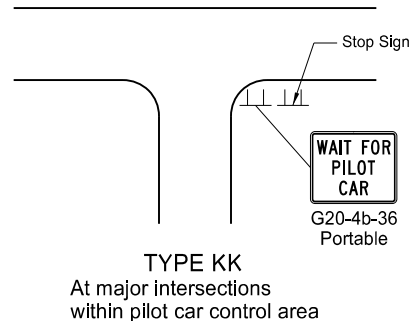

TYPE KK
At major intersections within pilot car control area

- Notes**
1. Re-establish speed limit. Determine exact speed limit in the field, dependent on location and conditions.
 2. Determine reduced speed limit based on in-place speed limit before construction. Where speed reductions exceed 30 mph, install a second speed limit sign with the desired speed reduction (not to exceed 30 mph.) Place the second speed limit sign at 1/2B.
 3. Install flags on warning signs in urban areas when signs are not portable. Mount 24 inch square flags perpendicular to the edges of the sign, and at such a distance above the edge that the flag does not touch the sign when limp.
 4. Cover existing speed limit signs within reduced speed zones.
 5. As an option, use portable sign supports in lieu of post mounted signs in accordance with NDDOT Standard Drawing D-704-14.
 6. Sign G20-55-96 is not required if this standard is part of other traffic control layouts, or work is less than 15 days.
 7. When pilot car operation is used, place sign G20-4b-36 "Wait For Pilot Car" at major intersections within pilot car control area.
 8. Recommend 40 mph speed limit in vicinity of workers, unless location and conditions dictate otherwise.
 9. Layouts shown for one direction only.

ADVANCE WARNING SIGN SPACING			
Road Type	Distance Between Signs Min. (ft)		
	A	B	C
Urban - Low Speed (30 mph or less)	150	150	150
Urban - Low Speed (over 30 to 40 mph)	280	280	280
Urban - High Speed (over 40 mph to 50 mph)	360	360	360
Rural - High Speed (over 50 mph to 65 mph)	720	720	720
Urban Expressway and Freeway (55 mph to 60 mph)	850	1350	2200
Rural Expressway and Freeway (70 mph to 75 mph)	1000	1500	2640
Interstate/4-Lane Divided (Maintenance and Surveying)	750	1000	1500

Longitudinal Buffer Space	
*Speed (mph)	Length Min (feet)
20	115
25	155
30	200
35	250
40	305
45	360
50	425
55	495
60	570
65	645
70	730
75	820

* Posted speed, off-peak 85th percentile speed prior to work starting, or the anticipated operating speed in mph.

NORTH DAKOTA DEPARTMENT OF TRANSPORTATION	
9-27-13	
REVISIONS	
DATE	CHANGE
8-17-17	Added speed limit signs. Updated notes & sign numbers.
11-01-19	Revised note 5 & sign numbers.

This document was originally issued and sealed by
Kirk J Hoff,
Registration Number
PE-4683,
on 11/1/19 and the original document is stored at the North Dakota Department of Transportation

MOBILE OPERATION
(PAVEMENT MARKING)

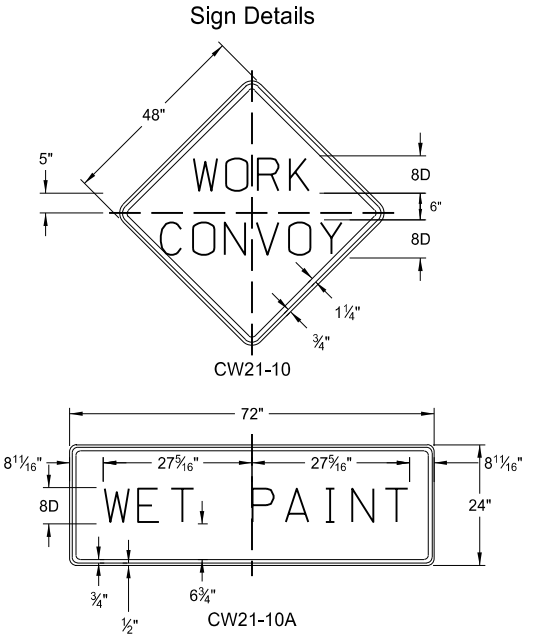
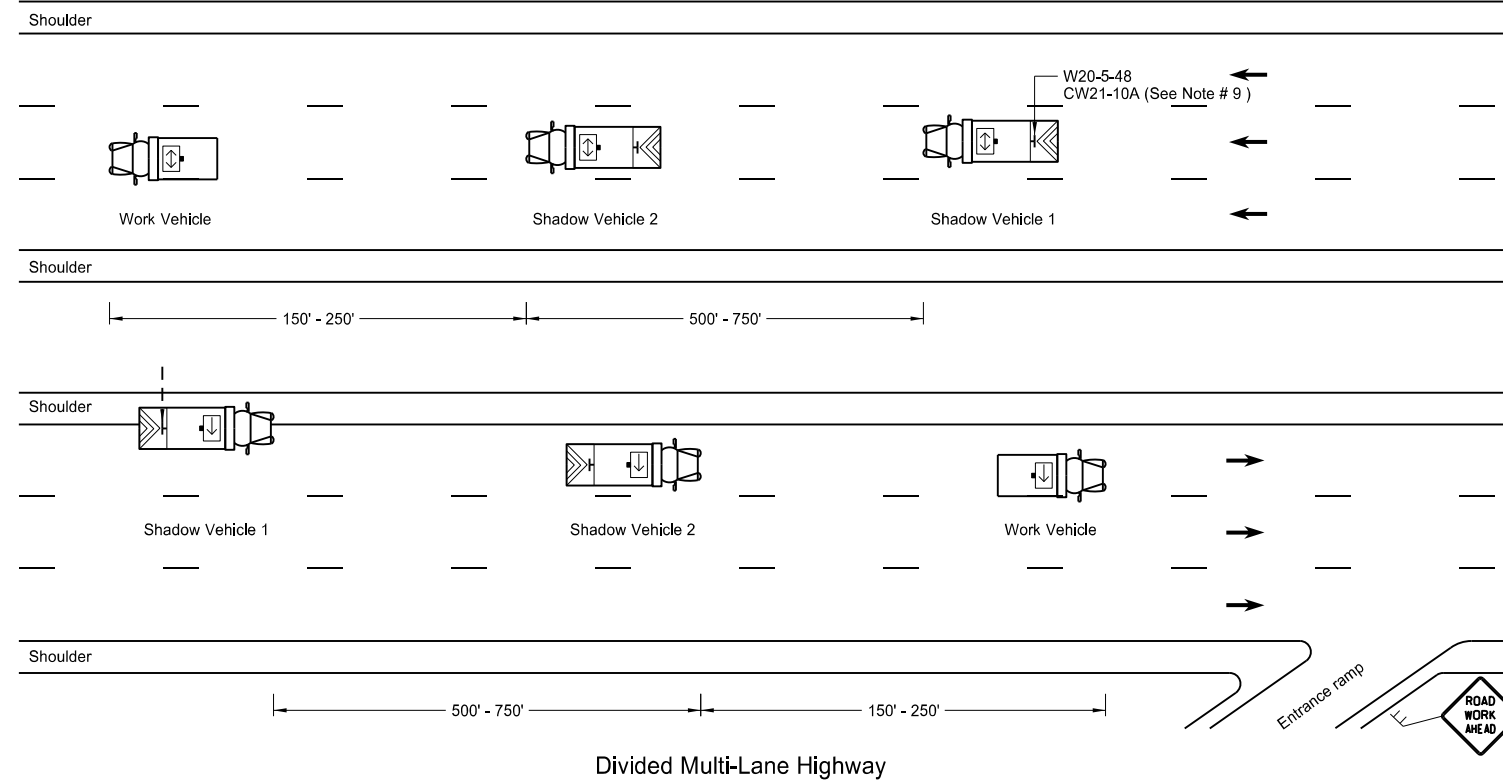
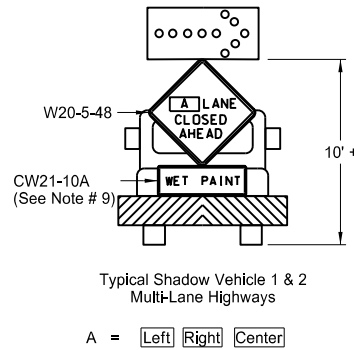
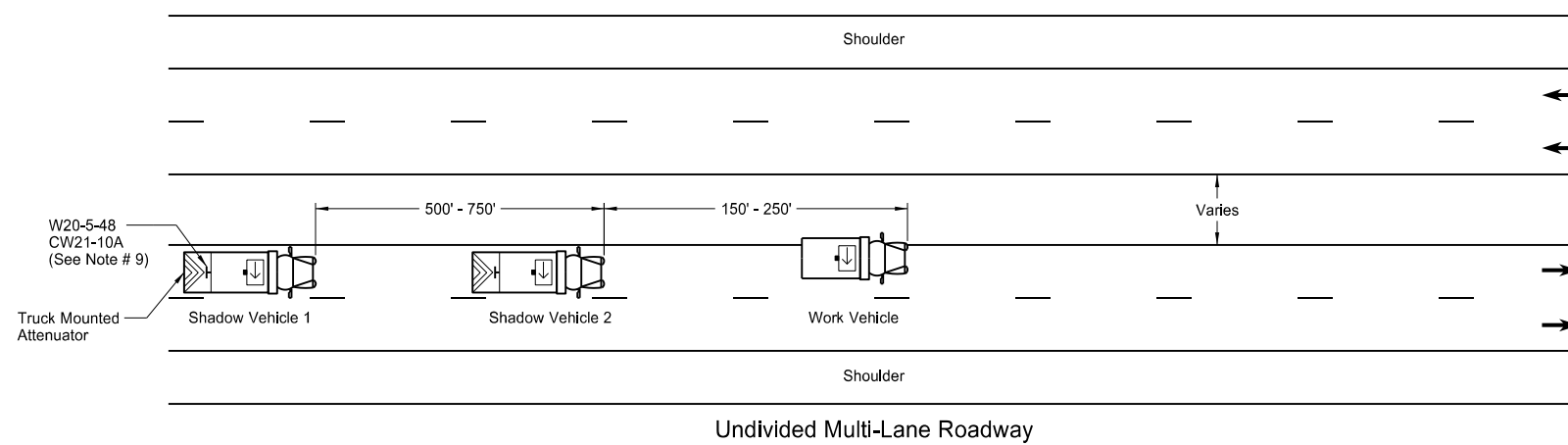
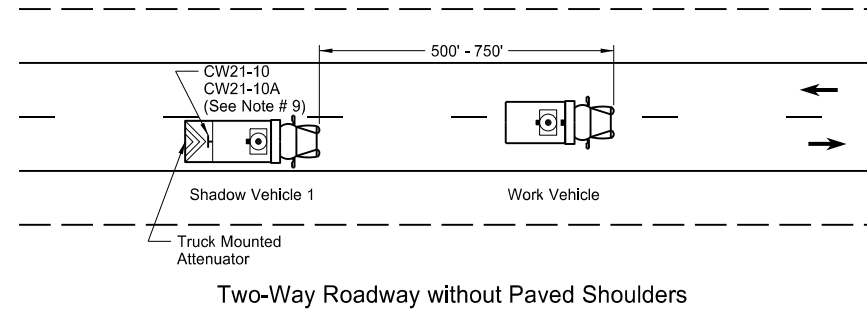
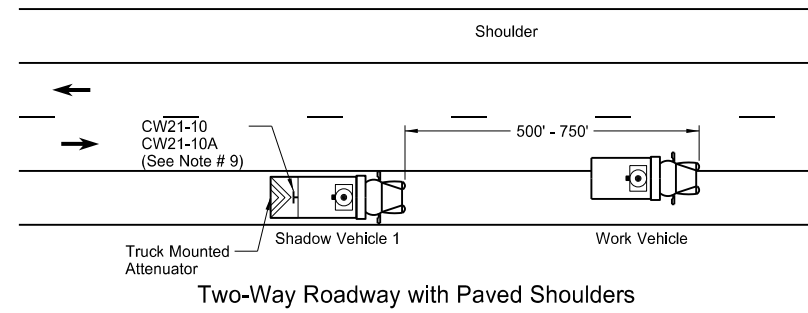
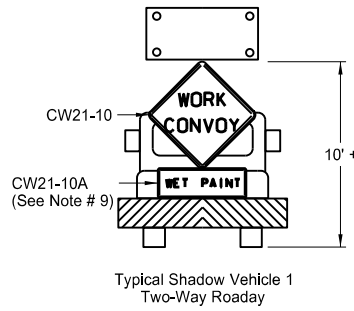

- Notes
1. Use additional vehicles you choose to be in the convoy with truck mounted attenuators, at your own expense.
 2. Display yellow rotating beacons or strobe lights on shadow and work vehicles, unless otherwise stated in the plans.
 3. Use Type B or Type C flashing arrow panels controlled from inside the vehicle.
 4. Provide each vehicle with two-way electronic communication capability.
 5. Move shadow vehicle 1 first to shadow other convoy vehicles when convoy changes lane.
 6. Vary vehicle spacing between shadow vehicle 1 and shadow vehicle 2 based on sight distance restrictions. Motorists approaching the work convoy need to see trail vehicle in time to slow down and/or change lanes as they approach shadow vehicle.
 7. Sign Colors
Letters = Black
Border = Black
Background = Orange
 8. As an option, use shadow vehicle 2 the paint tender vehicle.
 9. Use sign CW21-10A only during painting operation.
 10. Pull over work and shadow vehicles periodically to allow motor vehicle traffic to pass on two lane - two way roadways.

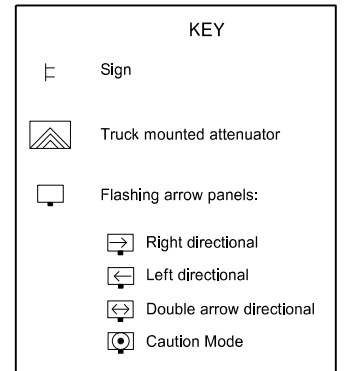

NORTH DAKOTA DEPARTMENT OF TRANSPORTATION	
9-27-13	
REVISIONS	
DATE	CHANGE
6-18-14	Removed shadow vehicle 2 on two lane roadways
9-27-17	Updated to active voice
11-08-19	Changed Standard Heading

This document was originally issued and sealed by
Kirk J Hoff,
Registration Number
PE-4683,
on 11/08/19 and the original document is stored at the
North Dakota Department
of Transportation

PORTABLE SIGN SUPPORT ASSEMBLY

D-704-50

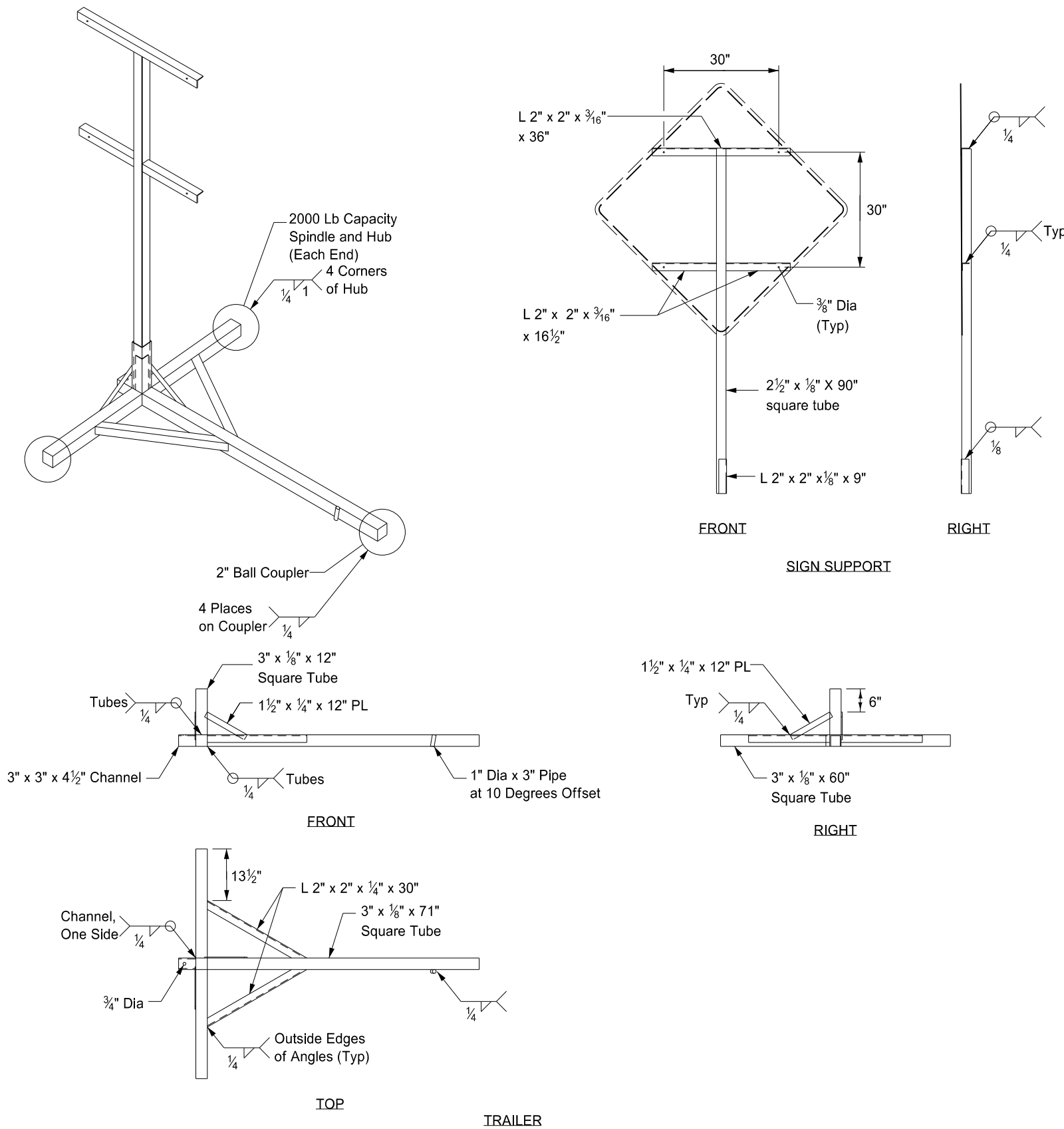

Notes:

- ① The maximum weight of the assembly is 250 pounds.
- ② Use a 14" wheel and tire.
- ③ Automotive and equipment axle assemblies may not be used for trailer-mounted sign supports.
- ④ Other NCHRP 350 crash tested assemblies are acceptable.

NORTH DAKOTA DEPARTMENT OF TRANSPORTATION	
11-23-10	
REVISIONS	
DATE	CHANGE

This document was originally issued and sealed by
 Roger Weigel
 Registration Number PE-2930,
 on 11/23/10 and the original document is stored at the
 North Dakota Department of Transportation

PAVEMENT MARKING

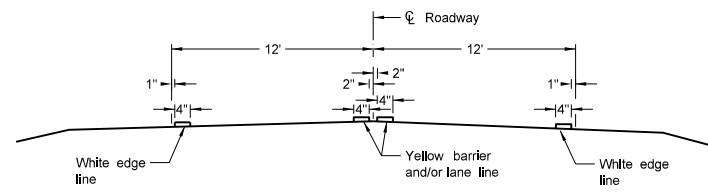

Two Lane Two Way
RURAL ROADWAY

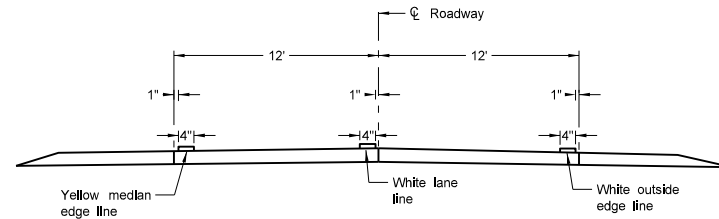

Two Lane Roadway
INTERSTATE HIGHWAY
Concrete Section

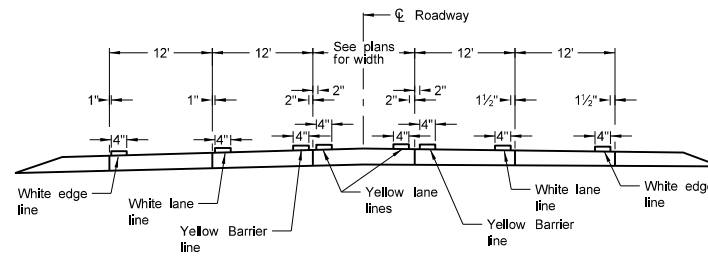

RURAL FIVE LANE ROADWAY
Concrete Section

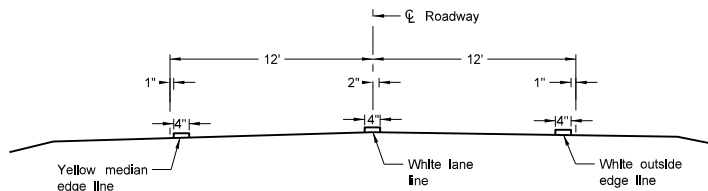

Two Lane Divided
Rural Roadway
PRIMARY HIGHWAY
Asphalt Section

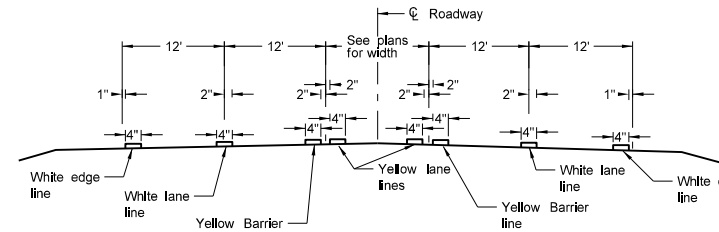

RURAL FIVE LANE ROADWAY
Asphalt Section

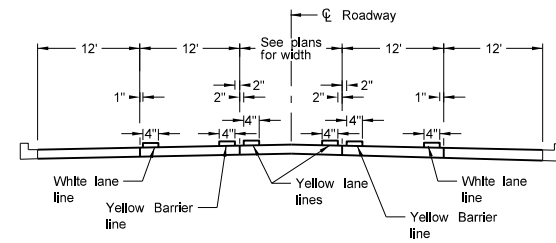

URBAN FIVE LANE SECTION
Concrete Section

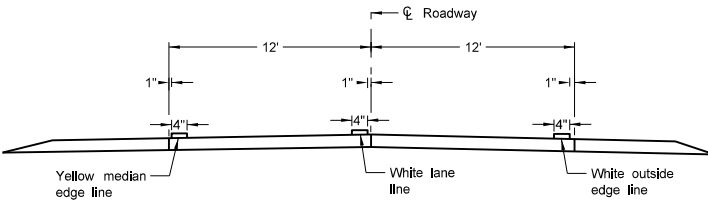

Two Lane Roadway
PRIMARY HIGHWAY
Concrete Section

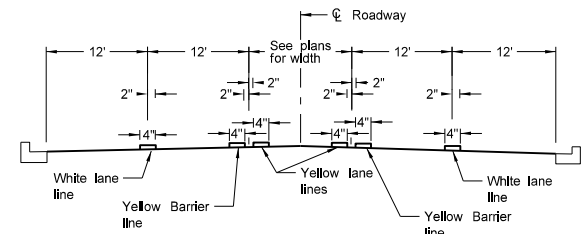

URBAN FIVE LANE SECTION
Asphalt Section

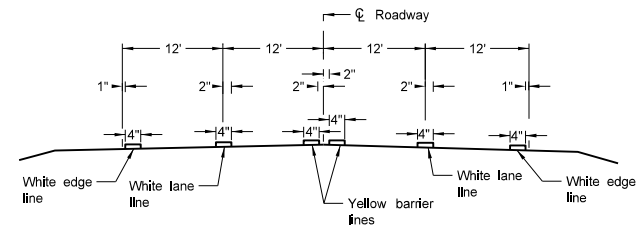

RURAL FOUR LANE ROADWAY
Asphalt Section

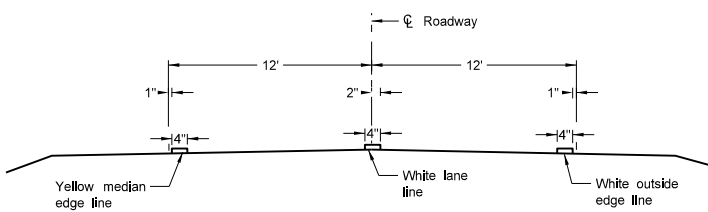

Two Lane Roadway
INTERSTATE HIGHWAY
Asphalt Section

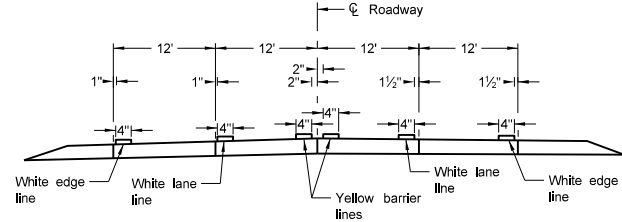

RURAL FOUR LANE ROADWAY
Concrete Section

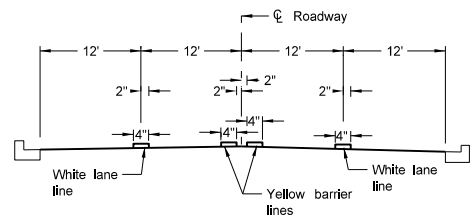

URBAN FOUR LANE SECTION
Asphalt Section

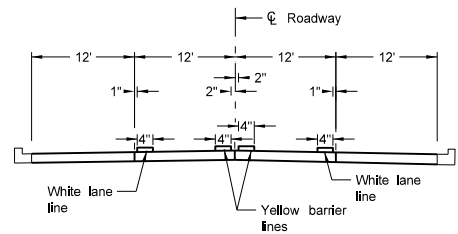

URBAN FOUR LANE SECTION
Concrete Section

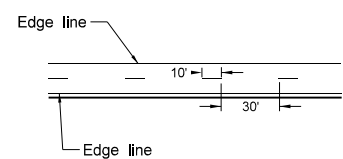

CENTERLINE PAVEMENT MARKING SKIP SPACING DETAIL

NOTES:
1. Continue edge lines through private drives and field drives. Break edge lines for intersections.

NORTH DAKOTA DEPARTMENT OF TRANSPORTATION	
12-1-10	
REVISIONS	
DATE	CHANGE
10-17-17	Updated to active voice.
08-27-19	New Design Engineer PE Stamp.

This document was originally issued and sealed by
Kirk J Hoff,
Registration Number
PE-4683,
on 8/27/19 and the original document is stored at the North Dakota Department of Transportation

SHORT-TERM PAVEMENT MARKING

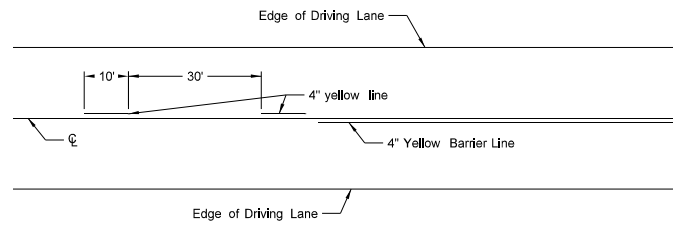

Painted or Tape Lines

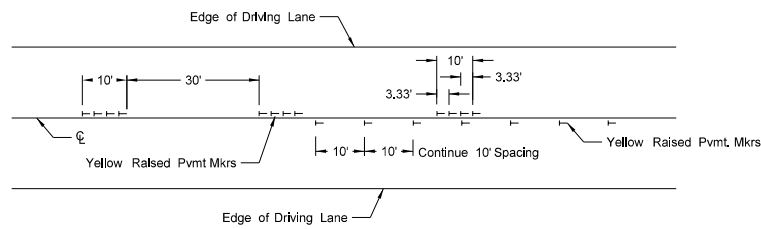

Raised Pavement Markers
TWO-LANE TWO-WAY ROADWAY

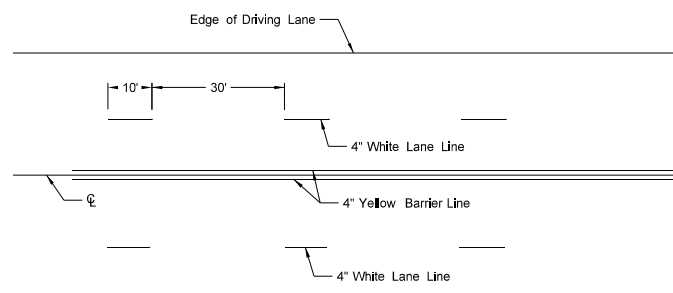

Painted or Tape Lines

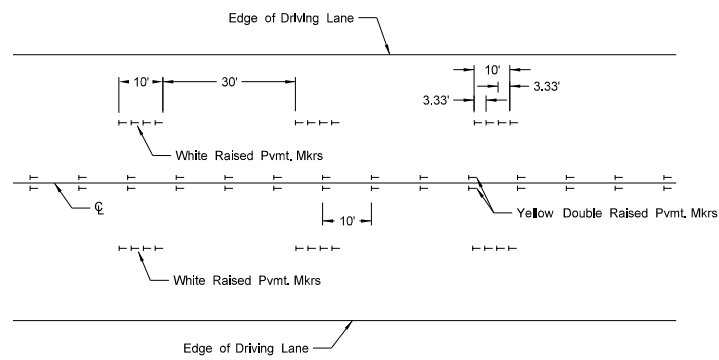

Raised Pavement Markers
FOUR LANE ROADWAY

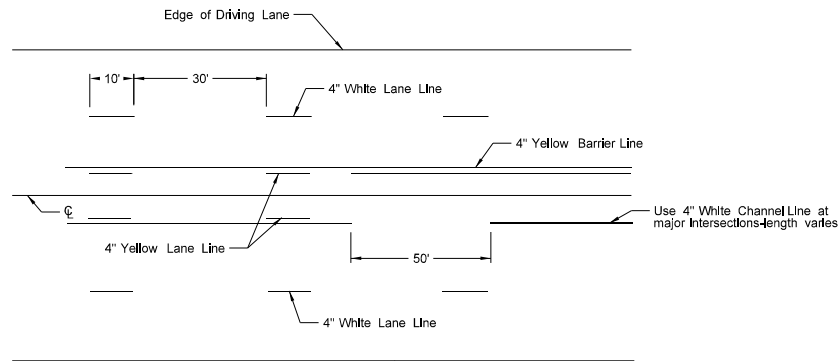

Painted or Tape Lines

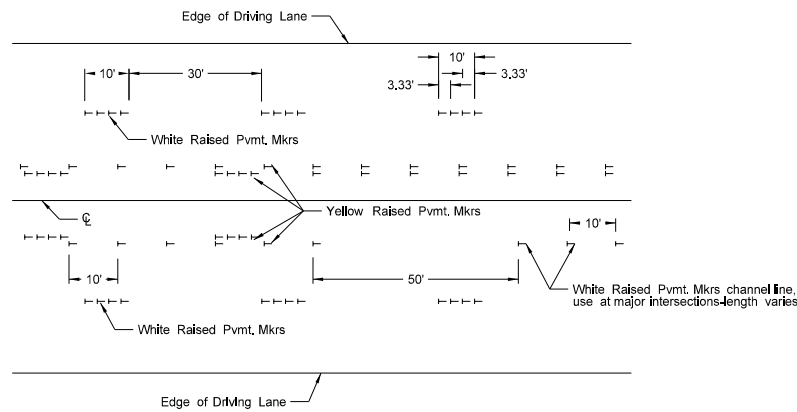

Raised Pavement Markers
FIVE LANE ROADWAY TWO WAY LEFT TURN

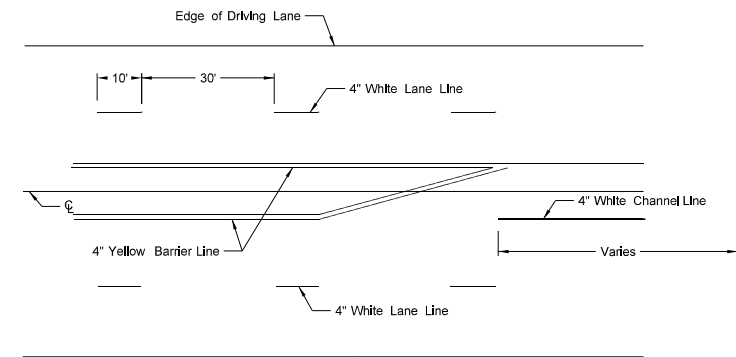

Painted or Tape Lines

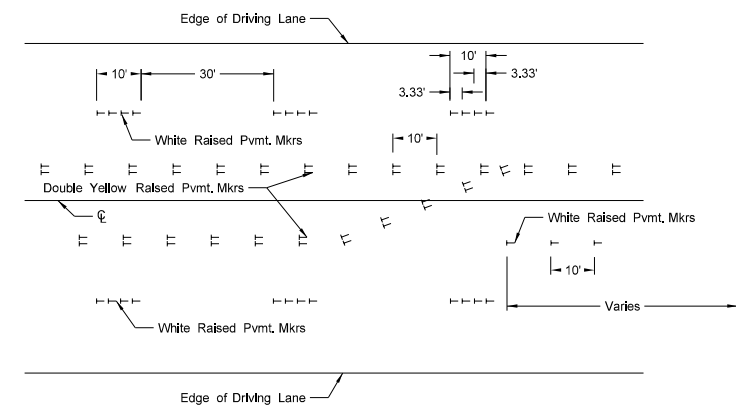

Raised Pavement Markers
FIVE LANE ROADWAY WITH MARKED ISLANDS

NOTES:

1. Place no passing zones on two-lane two-way roadways as shown. In lieu of short term no passing zone pavement markings, place no passing zone signs. Replace no passing zone signs with short term no passing zone pavement marking within three days.
2. Place short term center line stripe (paint) on top lift to match exact placement of permanent stripe.
3. Remove raised markers and tape markings after permanent pavement marking is installed.

NORTH DAKOTA DEPARTMENT OF TRANSPORTATION	
12-1-10	
REVISIONS	
DATE	CHANGE
3-29-16	Re-numbered to be D-762-11 (previously was D-762-6)
10-17-17	Updated to active voice.
8-27-19	New Design Engineer PE Stamp.

This document was originally issued and sealed by
Kirk J Hoff,
Registration Number
PE- 4683,
on 8/27/19 and the original document is stored at the North Dakota Department of Transportation