

DESIGN DATA				
Traffic	Average Daily			Max.Hr.
Current 2024	Pass: -	Trucks: -	Total: <750	-
Forecast -	Pass: -	Trucks: -	Total: <750	-
Clear Zone Distance: -	Design Speed: 55			
Minimum Sight Dist. for Stopping: 495				
Minimum Sight Dist. for Safe Passing: NA				
Sight Dist. for No Passing Zone: NA				

JOB # 24654

BOTTINEAU COUNTY NORTH DAKOTA

FEDERAL AID PROJECT
SC-0500(022)

HMA Repair, HMA Overlay, & Pavement Marking

CMC 0520 and CMC 0547 From 1 Mile South of
Gardena North 10 Miles to the Intersection of NDSH 5.

STATE	PROJECT NO.	PCN	SECTION NO.	SHEET NO.
ND	SC-0500(022)	24654	1	1

GOVERNING SPECIFICATIONS	Date Published and Adopted by the North Dakota Department of Transportation
Standard Specifications	07/01/2024
Supplemental Specifications	NONE

PROJECT NUMBER \ DESCRIPTION	NET MILES	GROSS MILES
SC-0500(022) - HMA Repair, HMA Overlay	10.070	10.070
TOTAL:	10.070	10.070

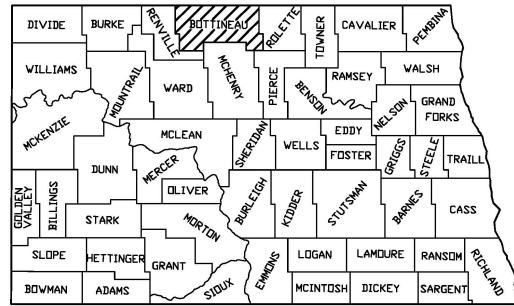

End Project: SC-0500(022)
Sta. 531+70.5= The Northeast Corner
Sec. 35, Twp. 162N, Rge. 76W

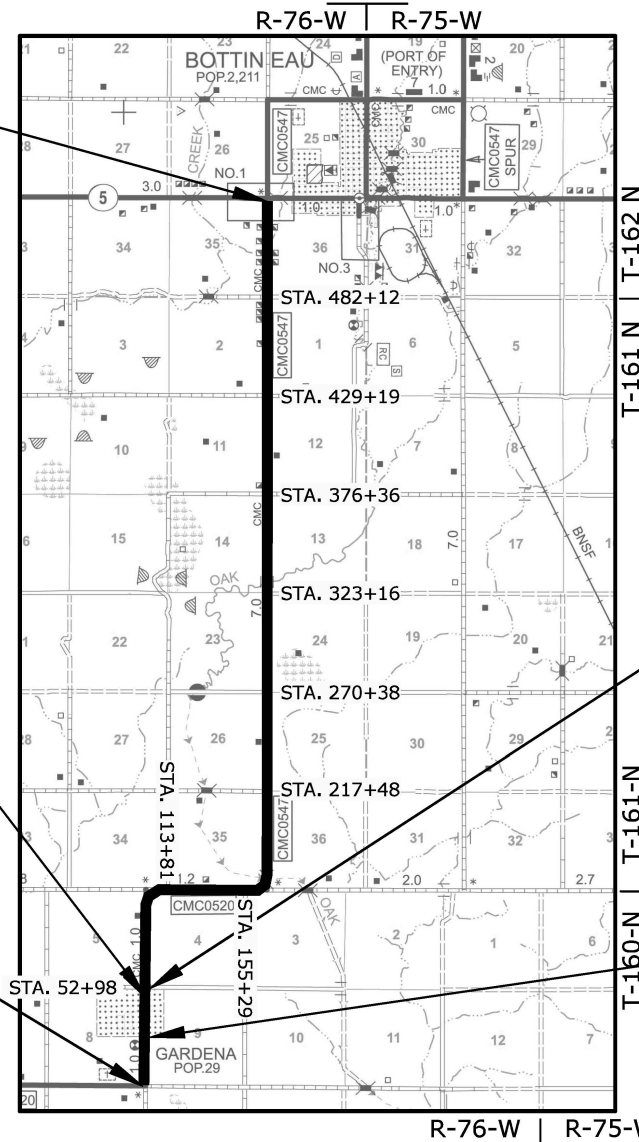

Abandoned Railroad Crossing
Northern Plains Railroad
= Sta. 41+56

CITY LIMITS
Sta. 52+98 = The NW Corner of
Sec. 9, Twp. 160-N, Rge. 76-W

Begin Project: SC-0500(022)
Sta. 0+00= The Southeast Corner
Sec. 8, Twp. 160-N, Rge. 76-W

CITY LIMITS
Sta. 26+30 = A Point 2,630 FT
North of the Southeast Corner of
Sec. 8, Twp. 160-N, Rge. 76-W

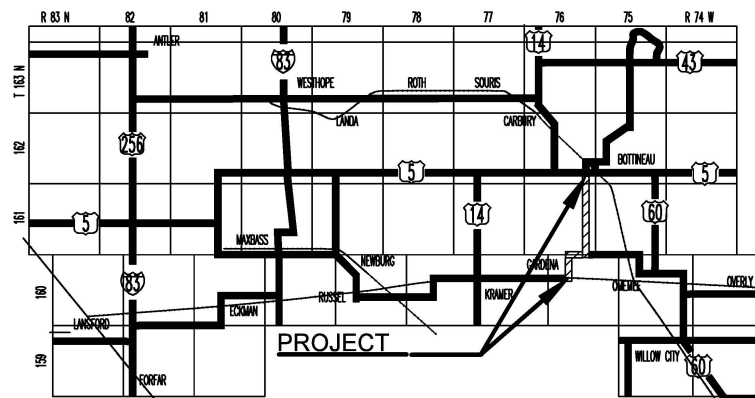

SKETCH MAP OF BOTTINEAU COUNTY

DESIGNER Kent D. Indvik, P.E.
DESIGNER Jesse R. Brandvold, P.E.
DESIGNER
DESIGNER

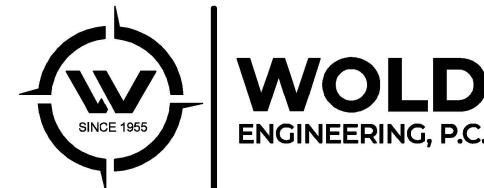

I hereby certify that the attached plans were prepared by me or under my direct supervision and that I am a duly registered professional engineer under the laws of the state of ND.

APPROVED DATE 08/21/2025

Jesse R. Brandvold, P.E. /s/

Wold Engineering, P.C.

This document was originally issued and sealed by Jesse R. Brandvold, Registration Number PE-40107 on 08/21/25 and the original document is stored at Wold Engineering, P.C. Bottineau, North Dakota

TABLE OF CONTENTS

	STATE	PROJECT NO.	SECTION NO.	SHEET NO.
	ND	SC-0500(022)	2	1

PLAN SECTIONS

LIST OF STANDARD DRAWINGS

Section	Page(s)	Description
1	1	Title Sheet
2	1	Table of Contents
6	1 - 2	Notes
8	1	Quantities
10	1	Basis of Estimate
20	1	General Details
30	1 - 2	Typical Sections
100	1 - 2	Work Zone Traffic Control
120	1	Pavement Marking

Number	Description
D-101-1, 2,3,4	NDDOT Abbreviations
D-101-10	NDDOT Utility Company and Organization Abbreviations
D-101-20, 21	Line Styles
D-101-30, 31,32,33	Symbols
D-704-7	Breakaway Systems For Construction Zone Signs - Perforated Tube
D-704-8	Breakaway Systems For Construction Zone Signs - U-Channel Post
D-704-9	Construction Sign Details - Terminal And Guide Signs
D-704-10	Construction Sign Details - Regulatory Signs
D-704-11, 11A	Construction Sign Details - Warning Signs
D-704-13	Barricade And Channelizing Device Details
D-704-14	Construction Sign Punching And Mounting Details
D-704-15	Road Closure Layouts
D-704-20	Terminal And Seal Coat Sign Layouts
D-704-22	Construction Truck And Temporary Detour Layouts
D-704-26	Miscellaneous Sign Layouts
D-704-27	Mobile Operation (Pavement Marking)
D-704-50	Portable Sign Support Assembly
D-706-1	Bituminous Laboratory
D-762-1	Pavement Marking Message Details
D-762-4	Pavement Marking

NOTES

STATE	PROJECT NO.	SECTION NO.	SHEET NO.
ND	SC-0500(022)	6	1

- 100-P01 COMPLETION DATE: This project as a whole has a completion date of October 17, 2026.
- 100-P02 PAVEMENT PROTECTION: The Contractor will protect the existing pavement. The Contractor will repair any pavement damaged due to their operations before the project will be accepted. Repairs will be made at the Contractor's expense and may include, but are not limited to: sawing, removals and additional hot bituminous pavement to damaged areas.
- 105-P01 TYPICAL SECTION: The dimensions shown for the bituminous pavement course are approximate. Plan quantities will be placed throughout except where the Engineer authorizes a change.
- 107-P01 HAUL ROADS: The Contractor will contact the appropriate Tribal, State, County, Township or City officials to determine if there are any No Haul Routes or Restricted Routes prior to preparing a bid for this project. All haul routes must be approved in writing by the local agency and approved by the Engineer. The gross vehicle weight on all county and township roads will not exceed the legal load limits unless approved by the local agency.
- 230-P01 SHOULDER PREPARATION: All vegetation that is within 6 feet of the asphalt shoulder will be chemically killed as per NDDOT Std. Specs. Sec. 230.04 B. The Contractor will mow the grass shoulders a minimum of ten (10) feet beyond the pavement edge and to a height not greater than three (3) inches just prior to application of the herbicide. All material and costs associated with "Shoulder Preparation" will be included in the project as a whole.
- 411-P01 MILLING PAVEMENT SURFACE: The Contractor will mill areas as indicated on plan. Payment for milling will be by the square yard based on widths shown on the basis of estimate. In subgrade repair areas, the full depth of the existing pavement will be milled and removed prior to the excavation.

The milled material will be produced in such a way that the maximum particle size is less than or equal to 1 ½ inches. The Contractor may use whatever means/methods of their choosing to remove any oversized milled material (greater than 1 ½ inches). Millings will be stockpiled at the Bottineau County shop in Bottineau. Coordinate the stockpiling and quantities for shop location with the County; Contact: Ritch Gimbel (701) 263-1607. All costs associated with salvaging, delivering, and stockpiling the millings will be included in the price bid for "Milling Pavement Surface".
- 411-P02 TEMPORARY ASPHALT WEDGES: The Contractor must place temporary asphalt or milled material wedges at the milled taper locations to allow for the smooth passage of vehicles. Wedges are to have a minimum slope of 4:1. All costs for labor, materials, and equipment to install and remove the wedges will be included in the unit price bid for "Milling Pavement Surface".

- 430-P01 LEVELING COURSE: Place a paver laid 0.5" leveling course at rate of approximately 220-295 tons per lane mile in the driving lanes. The leveling course should be used to correct rutting and cross-slope of the driving lanes and fill in shoulders of the existing road. Use the same type of mix that is required for the subsequent lift. Use a pneumatic roller as specified in Section 151.01 A.3. "Self-Propelled Pneumatic-Tired Roller" to compact the mix.
- 430-P02 HMA PAVING – PROTECTION OF UTILITIES: Exercise care during HMA paving operations to ensure utilities do not become covered with HMA. Cover all manholes, gate valves, and other utilities located within the paving areas to prevent these utilities from being covered with HMA. Removal of unwanted HMA from these areas will be completed to the satisfaction of the Engineer at the Contractor's expense.
- 430-P03 MIX DESIGN: The mix design will be Contractor developed with the aggregate and asphalt to be used on the project. The mix design will be done in the manner specified in NDDOT Standard Specification Section 430, prior to the start of the paving operation. The Contractor will submit a HMA mix design to the Engineer 10 days prior to the start of the construction. Include all costs associated with the mix design in the unit price bid for "Superpave FAA 42."
- 430-P04 COMPACTION: Compaction of hot mix asphalt will be in accordance to NDDOT Standard Specification Section 430.04 I.3 Ordinary Compaction. The compaction equipment used will include not less than two vibratory rollers.
- 430-P05 PG ASPHALT ACCEPTANCE: The Engineer will accept asphalt cement as outlined in the Combined State Binder Group agreement for North Dakota. The asphalt cement supplier will provide manifests as outlined in the Combined State Binder Group agreement for North Dakota, but no asphalt cement samples or testing will be required at the point of delivery.
- 430-P06 HOT MIX ASPHALT: Superpave FAA 42 will have the aggregate and mix design properties as shown in Table 430-03, with this exception – the number of gyrations used in the mix design will be 50, as well as N_{initial}=6 and N_{max}=75.
- 430-P07 APPROACH PAVING: The approaches will be paved prior to or concurrent with the placement of the mainline top lift. An adequate transition to match existing conditions will be required.

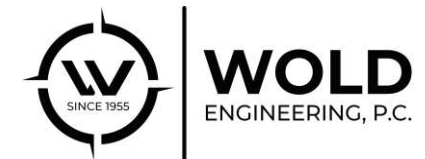

This document was originally issued and sealed by
 Jesse R. Brandvold,
 Registration Number
 PE-40107
 on 08/21/25 and the original document is stored at
 Wold Engineering, P.C.
 Bottineau, North Dakota

NOTES

STATE	PROJECT NO.	SECTION NO.	SHEET NO.
ND	SC-0500(022)	6	2

430-P08 NEW APPROACH PAVING: There are approximately 5 approaches without existing asphalt. The existing aggregate material on these approaches will need to be removed to a depth that will allow for 4" of new HMA on the paved aprons. All costs associated with this work will be included in the unit price bid for "Superpave FAA 42".

430-P09 ADJACENT LIFTS: In pavement repair areas the previous lift will be allowed to cure prior to paving the next lift.

704-P01 TRAFFIC CONTROL FOR UNEVEN PAVEMENT: The Contractor has the option of making the paving lanes even at the end of each day's paving operation or signing for the uneven pavement and providing the following devices: Install "Uneven Lanes" signs (Sign No. W8-11-48) and a supplemental plate (Sign No. W20-52-54), identifying the distance, on the right shoulder (both directions) in advance of the beginning of the uneven pavement and at major intersections. A major intersection will be defined as a CMC, state, U.S. highway, or Interstate ramp. Install "Do Not Pass" signs (Sign No. R4-1-48) on the right shoulder (both directions) between the uneven lanes sign and the beginning of the uneven pavement and at major intersections. Install tubular markers spaced at two times the posted speed limit on the centerline where uneven pavement exists.

These traffic control devices will be left in place until the lanes are even. These signs and tubular markers are included in the "Traffic Control Devices List" and will be measured and paid for at the contract unit price for each device. No extra compensation will be allowed for relocation due to work progression.

704-P02 TRAFFIC CONTROL: Traffic control for the paving will consist of a temporary road closure, flagging, and a pilot car. Traffic Control Devices will comply with the following Standard Drawings:

1. Standard D-704-15, layout A: For temporary roadway closure during paving operations.
2. Standard D-704-20, layout G: For construction signing during paving operations. Sign G20-1b-60 will not be required. Signs R2-1-48 and R2-1a-24 are to be moved as the work area moves through the construction zone and should be placed a minimum of 500 feet in advance of flagging signs. Signs will be required at the junctions shown on the Traffic Control Layout.
3. Standard D-704-22, layouts K and L: For trucks hauling material.
4. Standard D-704-26, layouts CC, EE, and GG: For paving operations.
5. Standard D-704-7,8,9,10,11,13, and 14 are applicable.

The required traffic control signs and devices are included in the "Traffic Control Devices List" and will be measured and paid at the contract unit price for each device.

The Department will pay for all necessary deployed devices, regardless of the length of the lane closure.

704-P03 TRAFFIC CONTROL DURING WORKING AND NON-WORKING HOURS: The Contractor will maintain one lane of traffic at the posted speed limit at all times during working hours. During non-working hours, the Contractor will leave the work area free of all hazards. The Contractor will open the roadway to two-way traffic during non-working hours. A minimum 24 foot roadway width will be required to maintain two lanes of traffic.

During paving and milling operations, flagging and pilot car will be used to maintain traffic during working hours. The traffic control devices for flagging will be removed at the end of each day and reinstalled when work commences.

704-P04 COVER SIGNS: Existing signs requiring covering will be covered with durable covering such as plywood or pressed board so that no damage is done to the sign face. If any damage is done, the signs will be replaced at the Contractor's expense. Alternate methods of covering may be used if approved by the Engineer. The cost of providing material and covering existing signing will not be bid separately but will be included in the traffic control items.

706-P01 BITUMINOUS LABORATORY: Supply a copy machine, with reduction capabilities, and toner. The payment for these items will be included in the price bid for "BITUMINOUS LABORATORY."

762-P01 SHORT-TERM PAVEMENT MARKINGS: The short-term application will be applied immediately following completion of the paving operation on the entire mainline. No intermediate application will be necessary while Sign No. W8-12-48, "No Center Stripe", is in place. Short-Term Pavement Marking will not be field measured unless the Engineer authorizes a change in the field and will be paid for at plan quantity.

762-P02 PERMANENT PAVEMENT MARKINGS: Permanent pavement markings will be placed no sooner than 14 days and no later than 21 days after completion of the paving.

762-P03 PAVEMENT MARKINGS EDGE LINES: Edge lines will be continued through private drives and broken at intersections and will be placed only upon completion of the pavement overlay.

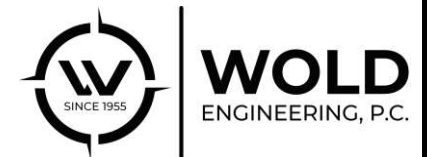

This document was originally issued and sealed by
Jesse R. Brandvold,
Registration Number
PE-40107
on 08/21/25 and the original document is stored at
Wold Engineering, P.C.
Bottineau, North Dakota

Estimated Quantities

STATE	PROJECT NO.	SECTION NO.	SHEET NO.
ND	SC-0500(022)	8	1

SPEC	CODE	ITEM DESCRIPTION	UNIT	Mainline:	Approaches:	Pvmt Repair:	TOTAL
103	0100	CONTRACT BOND	L SUM	1			1
302	0120	AGGREGATE BASE COURSE CL 5	TON		700		700
401	0050	TACK COAT	GAL	17133	446	78	17657
411	0105	MILLING PAVEMENT SURFACE	SY	1110		1548	2658
430	0042	SUPERPAVE FAA 42	TON	20291	1750	288	22329
430	5815	PG 58S-34 ASPHALT CEMENT	TON	1259	116	17	1392
702	0100	MOBILIZATION	L SUM	1			1
704	0100	FLAGGING	MHR	600			600
704	1000	TRAFFIC CONTROL SIGNS	UNIT	1484			1484
704	1067	TUBULAR MARKERS	EA	250			250
704	1185	PILOT CAR	HR	300			300
706	0550	BITUMINOUS LABORATORY	EA	1			1
706	0600	CONTRACTOR'S LABORATORY	EA	1			1
762	0103	PVMT MK PAINTED-MESSAGE	SF	52			52
762	0430	SHORT TERM 4IN LINE-TYPE NR	LF	37665			37665
762	1106	PVMT MK PAINTED 6IN LINE	LF	144000			144000
762	1124	PVMT MK PAINTED 24IN LINE	LF	40			40

STATE	PROJECT NO.	SECTION NO.	SHEET NO.
ND	SC-0500(022)	10	1

BASIS OF ESTIMATE - ROADWAY

STA. 0+00 TO STA. 94+75, STA. 112+80 TO STA. 158+80, & STA. 170+00 TO STA. 531+70.5 (9.516 miles)				
QUANTITY PER MILE	WIDTH	TOTAL	UNIT	DESCRIPTION
821	28'	7,816	GAL	EMULSIFIED ASPHALT FOR TACK COAT AT 0.05 GAL/SY (LEVELING COURSE)
587	28'	5,583	TON	SUPERPAVE FAA 42 HOT BITUMINOUS PAVEMENT AT 2.0 TON/CY (0.5" LEVELING COURSE)
36	28'	346	TON	PG58S-34 ASPHALT CEMENT FOR SUPERPAVE FAA 42 AT 6.2% (0.5" LEVELING COURSE)
880	30'	8,374	GAL	EMULSIFIED ASPHALT FOR TACK COAT AT 0.05 GAL/SY (SURFACE COURSE)
1,439	26'	13,696	TON	SUPERPAVE FAA 42 HOT BITUMINOUS PAVEMENT AT 2.0 TON/CY, 2' SLOUGH (1.5" SURFACE COURSE)
89	26'	849	TON	PG58S-34 ASPHALT CEMENT FOR SUPERPAVE FAA 42 AT 6.2%, 2' SLOUGH (1.5" SURFACE COURSE)
STA. 94+75 TO STA. 112+80 & STA. 158+80 TO STA. 170+00 (0.554 miles)				
QUANTITY PER MILE	WIDTH	TOTAL	UNIT	DESCRIPTION
821	28'	455	GAL	EMULSIFIED ASPHALT FOR TACK COAT AT 0.05 GAL/SY (LEVELING COURSE)
442	28'	245	TON	SUPERPAVE FAA 42 HOT BITUMINOUS PAVEMENT AT 2.0 TON/CY (0.5" LEVELING COURSE)
28	28'	16	TON	PG58S-34 ASPHALT CEMENT FOR SUPERPAVE FAA 42 AT 6.2% (0.5" LEVELING COURSE)
881	30'	488	GAL	EMULSIFIED ASPHALT FOR TACK COAT AT 0.05 GAL/SY (SURFACE COURSE)
1,384	26'	767	TON	SUPERPAVE FAA 42 HOT BITUMINOUS PAVEMENT AT 2.0 TON/CY, 2' SLOUGH (1.5" SURFACE COURSE)
87	26'	48	TON	PG58S-34 ASPHALT CEMENT FOR SUPERPAVE FAA 42 AT 6.2%, 2' SLOUGH (1.5" SURFACE COURSE)
PAVEMENT REPAIR - FULL DEPTH MILL & 5" HMA - *SEE MILLING TABLE FOR LOCATIONS (0.063 miles)				
QUANTITY PER MILE	WIDTH	TOTAL	UNIT	DESCRIPTION
704	24'	44	GAL	EMULSIFIED ASPHALT FOR TACK COAT AT 0.05 GAL/SY
3,920	24'	245	TON	SUPERPAVE FAA 42 HOT BITUMINOUS PAVEMENT AT 2.0 TON/CY
240	24'	15	TON	PG58S-34 ASPHALT CEMENT FOR SUPERPAVE FAA 42 AT 6.2%
PAVEMENT REPAIR - 1" MILL & 1" HMA - *SEE MILLING TABLE FOR LOCATIONS (0.055 miles)				
QUANTITY PER MILE	WIDTH	TOTAL	UNIT	DESCRIPTION
709	24'	39	GAL	EMULSIFIED ASPHALT FOR TACK COAT AT 0.05 GAL/SY
782	24'	43	TON	SUPERPAVE FAA 42 HOT BITUMINOUS PAVEMENT AT 2.0 TON/CY
55	24'	3	TON	PG58S-34 ASPHALT CEMENT FOR SUPERPAVE FAA 42 AT 6.2%

BASIS OF ESTIMATE - MARKING

PAVEMENT MARKING PAINTED LINE (PERMANENT)			
CENTERLINE: 6" YELLOW, 10 FT. LINES, 30 FT. SKIP 1320 LF/MILE			
BARRIER LINES: 6" YELLOW 4" BETWEEN LINES			
EDGE LINE: 6" WHITE 10,560 LF/MILE			
BARRIER:			
STA. 0+50 TO STA. 9+00 LT	=	850 LF	STA. 279+90 TO STA. 292+20 LT = 1,230 LF
STA. 31+40 TO STA. 42+50 RT	=	1,110 LF	STA. 290+85 TO STA. 307+00 RT = 1,615 LF
STA. 33+35 TO STA. 49+50 LT	=	1,615 LF	STA. 300+85 TO STA. 316+85 LT = 1,600 LF
STA. 85+80 TO STA. 111+35 RT	=	2,555 LF	STA. 331+70 TO STA. 340+60 RT = 890 LF
STA. 93+25 TO STA. 114+20 LT	=	2,095 LF	STA. 341+70 TO STA. 350+25 LT = 855 LF
STA. 153+60 TO STA. 172+80 RT	=	1,920 LF	STA. 496+70 TO STA. 530+70 LT = 3,400 LF
STA. 154+80 TO STA. 177+80 LT	=	2,300 LF	STA. 496+70 TO STA. 530+70 RT = 3,400 LF
STA. 269+90 TO STA. 281+40 RT	=	1,150 LF	
SHORT-TERM 4IN LINE-TYPE NR:			
			BROKEN LINE = 11,080 LF
			BARRIER LINE = 26,585 LF
			TOTAL = 37,665 LF
PVMT MK PAINTED 6IN LINE:			
			BROKEN LINE = 11,080 LF
			BARRIER LINE = 26,585 LF
			EDGE LINE = 106,335 LF
			TOTAL = 144,000 LF
PVMT MK PAINTED-MESSAGE: STA. 519+05 RT - STOP AHEAD = 52 SF			
PVMT MK 24IN LINE: (2 STOP BARS) = 40 LF			

BASIS OF ESTIMATE - MILLING

LOCATION	WIDTH	UNIT	QUANTITY
B.O.P. CO RD 20 INTERSECTION (0" TO 2" TRANSITION)	VARIES	SY	370
STA. 41+36 TO STA. 41+76 - ABANDONED RR XING (1")	24'	SY	107
STA. 49+20 LT TO STA. 50+00 LT (FULL DEPTH)	12'	SY	107
STA. 170+00 TO STA. 172+50 - BRIDGE (1")	24'	SY	667
STA. 315+00 TO STA. 315+50 (FULL DEPTH)	24'	SY	133
STA. 329+40 TO STA. 331+40 - PIPE (FULL DEPTH)	24'	SY	534
E.O.P. NDSH 5 INTERSECTION (0" TO 2" TRANSITION)	VARIES	SY	740
TOTAL:			2,658 SY

BASIS OF ESTIMATE - APPROACHES

DESCRIPTION	UNIT	SECTION LINE	PRVATE DR	FIELD	TOTAL
NUMBER OF LOCATIONS	#	16	35	38	89
AGGREGATE BASE COURSE CL 5	TON	10	10	5	700
TACK COAT	GAL	10	6	2	446
SUPERPAVE FAA 42	TON	30	20	15	1750
PG 58S-34 ASPHALT CEMENT	TON	2	1.3	1	116

BASIS OF ESTIMATE - FLAGGING & PILOT CAR

DESCRIPTION	BASIS	QUANTITY
FLAGGING	30 MHR/MILE/LIFT	600 MHR
PILOT CAR	15 HR/MILE/LIFT	300 HR

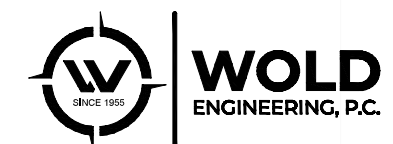

This document was originally issued and sealed by
 Jesse R. Brandvold,
 Registration Number
 PE-40107
 on 08/21/25 and the original document is stored at
 Wold Engineering, P.C.
 Bottineau, North Dakota

BASIS OF ESTIMATE

STATE.	PROJECT NO.	SECTION NO.	SHEET NO.
ND	SC-0500(022)	20	1

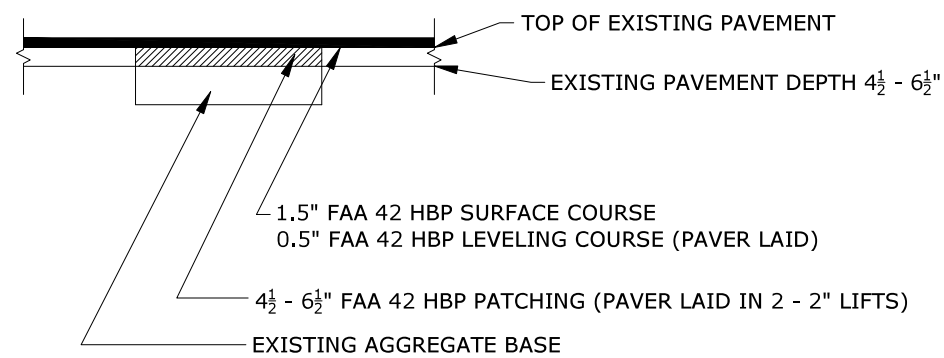
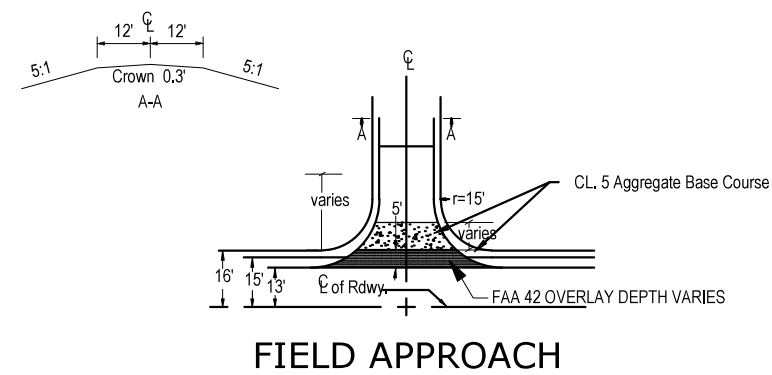
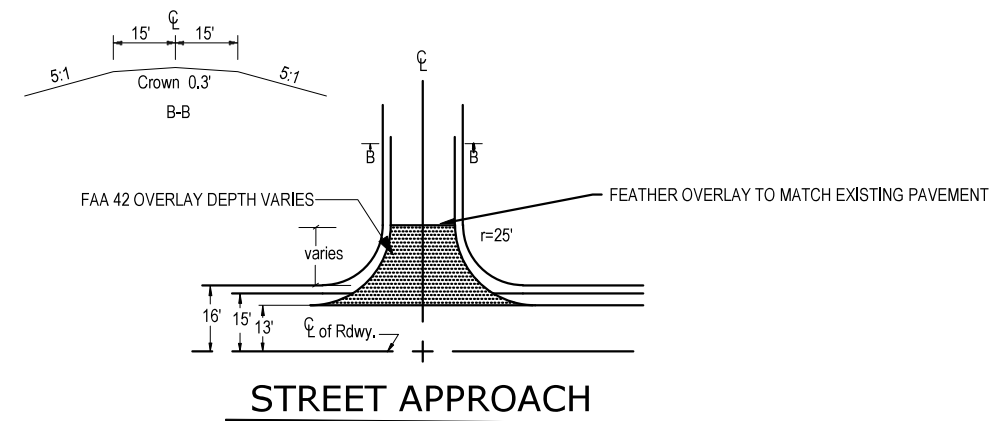
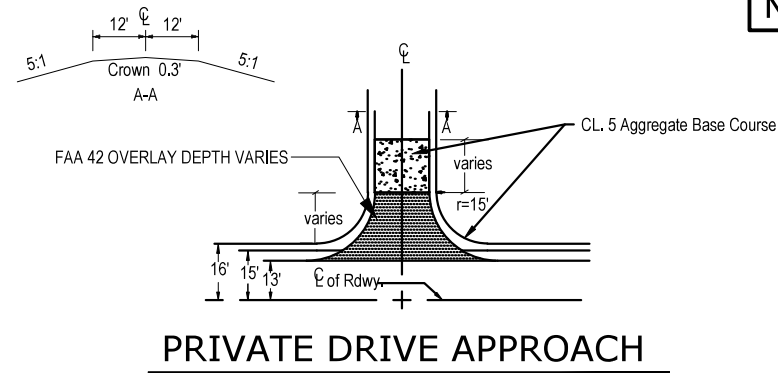
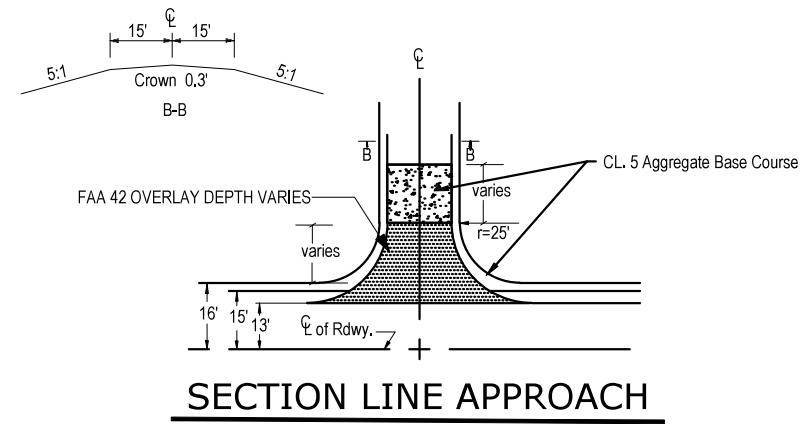

STA. 49+20 LT TO 50+00 LT
 STA. 315+00 TO 315+50
 STA. 329+40 TO 331+40

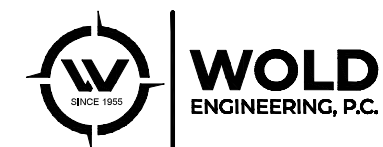
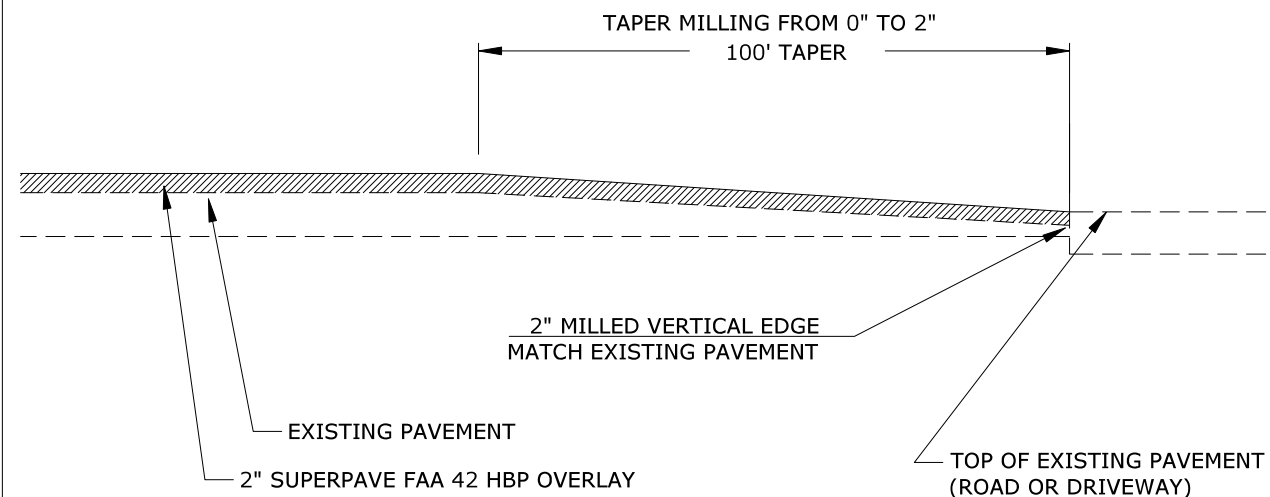

This document was originally issued and sealed by Jesse R. Brandvold, Registration Number PE-40107 on 08/21/25 and the original document is stored at Wold Engineering, P.C. Bottineau, North Dakota

APPROACH PAVING,
 PAVEMENT REPAIR &
 MILLING TRANSITION DETAILS

STATE	PROJECT NO.	SECTION NO.	SHEET NO.
ND	SC-0500(022)	30	1

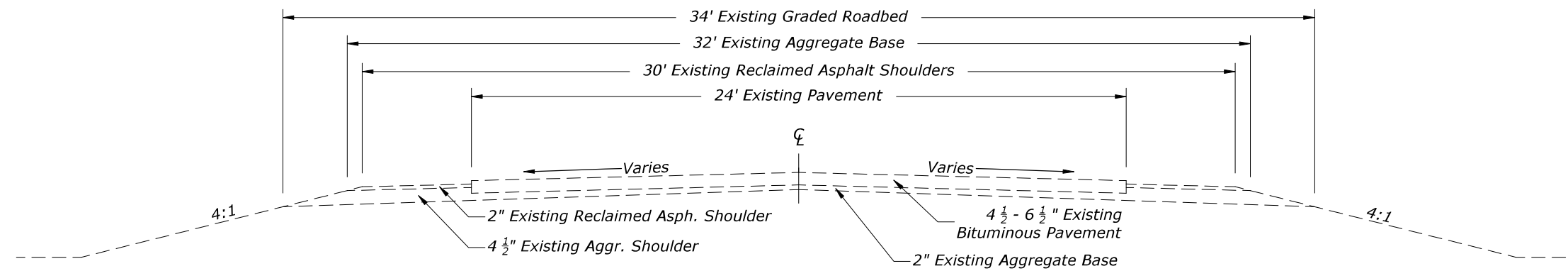

EXISTING TYPICAL SECTION
STA. 0+00 TO 94+75
STA. 112+80 TO 158+80
STA. 170+00 TO 531+70.5

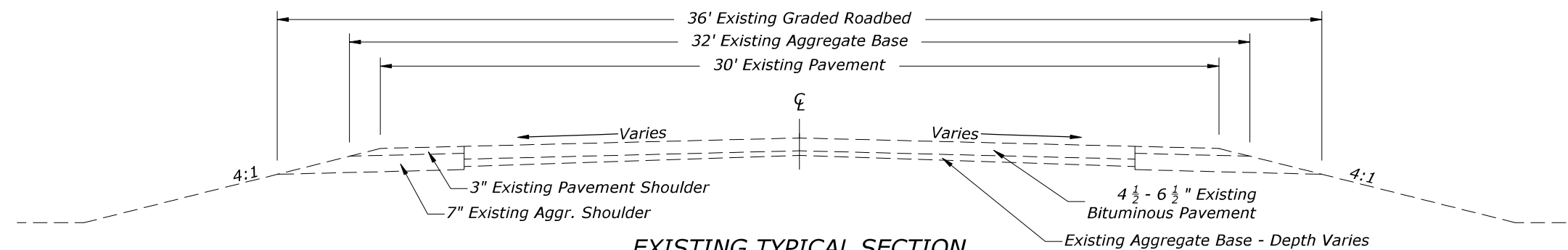

EXISTING TYPICAL SECTION
STA. 94+75 TO 112+80
STA. 158+80 TO 170+00

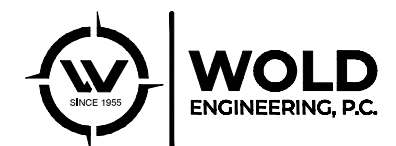

This document was originally issued and sealed by Jesse R. Brandvold, Registration Number PE-40107 on 08/21/25 and the original document is stored at Wold Engineering, P.C. Bottineau, North Dakota

**TYPICAL SECTIONS:
EXISTING**

STATE	PROJECT NO.	SECTION NO.	SHEET NO.
ND	SC-0500(022)	30	2

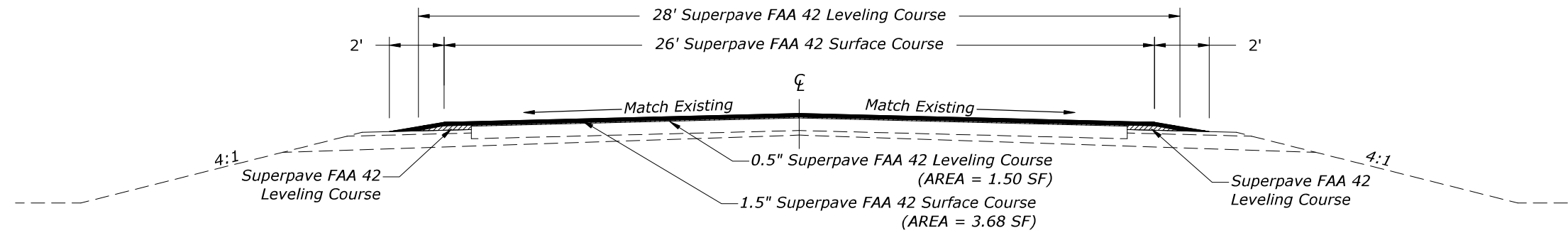

PROPOSED TYPICAL SECTION
STA. 0+00 TO 94+75
STA. 112+80 TO 158+80
STA. 170+00 TO 531+70.5

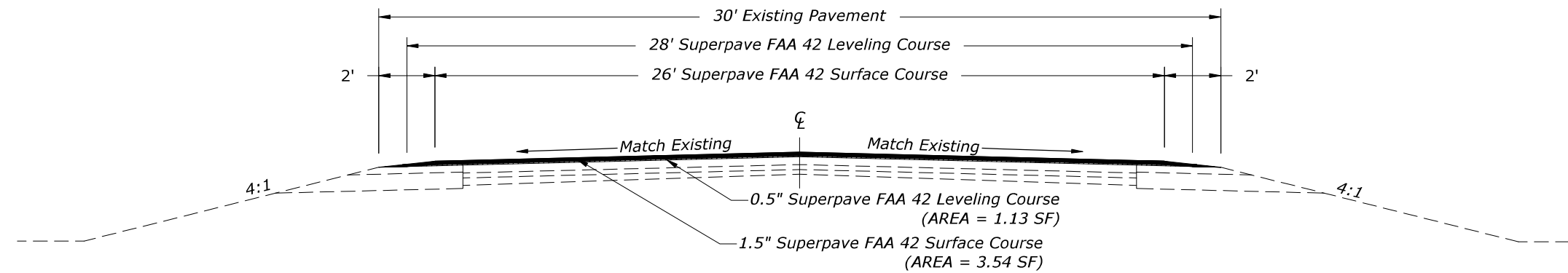

PROPOSED TYPICAL SECTION
STA. 94+75 TO 112+80
STA. 158+80 TO 170+00

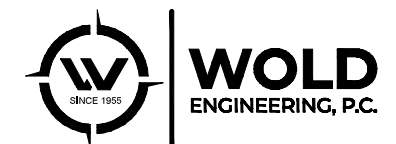

This document was originally issued and sealed by Jesse R. Brandvold, Registration Number PE-40107 on 08/21/25 and the original document is stored at Wold Engineering, P.C. Bottineau, North Dakota

**TYPICAL SECTIONS:
PROPOSED**

STATE.	PROJECT NO.	SECTION NO.	SHEET NO.
ND	SC-0500(022)	100	2

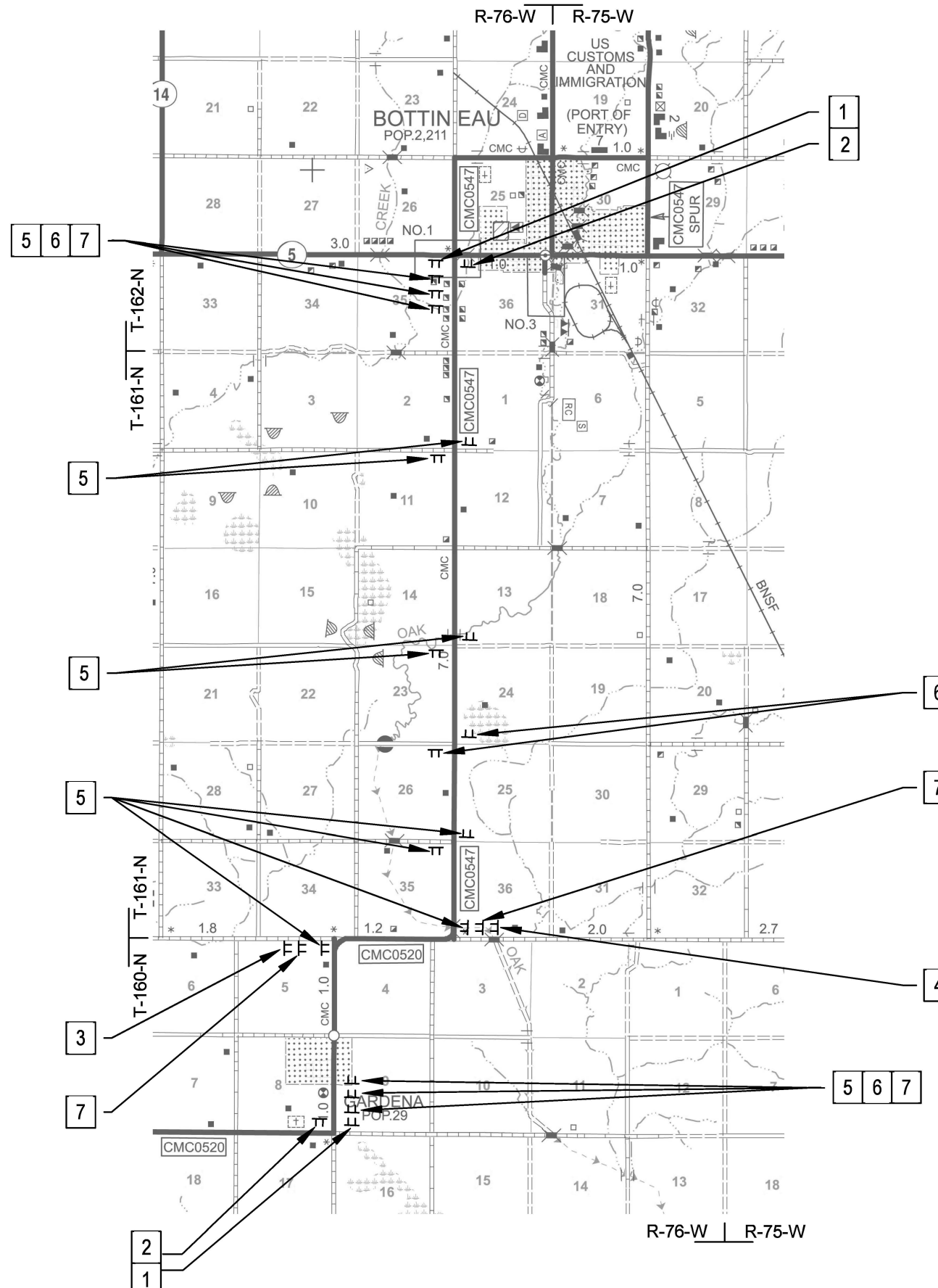

- | | | |
|---|---|--|
| 1 | 2 | |
| ROAD WORK
NEXT XX MILES

G20-1-60
Post Mounted | END
ROAD WORK

G20-2-48
Post Mounted | |
| 3 | 4 | |
| ROAD WORK
NEXT 8 MILES
NEXT 2 MILES
G20-50a-72
Post Mounted | ROAD WORK
NEXT 3 MILES
NEXT 7 MILES
G20-50a-72
Post Mounted | |
| 5 | 6 | 7 |
| NO
CENTER
LINE

W8-12-48
Post Mounted | DO
NOT
PASS

R4-1-48
Post Mounted | SPEED
LIMIT
XX

MINIMUM
FEE
\$150

R2-1-48
(40 MPH)
&
R2-1aP-24
Post Mounted |

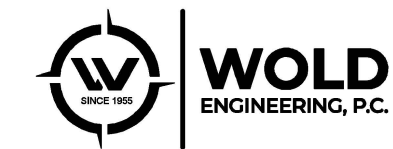

This document was originally issued and sealed by Jesse R. Brandvold, Registration Number PE-40107 on 08/21/25 and the original document is stored at Wold Engineering, P.C. Bottineau, North Dakota

**WORKZONE
TRAFFIC CONTROL
LAYOUT**

STATE	PROJECT NO.	SECTION NO.	SHEET NO.
ND	SC-0500(022)	120	1

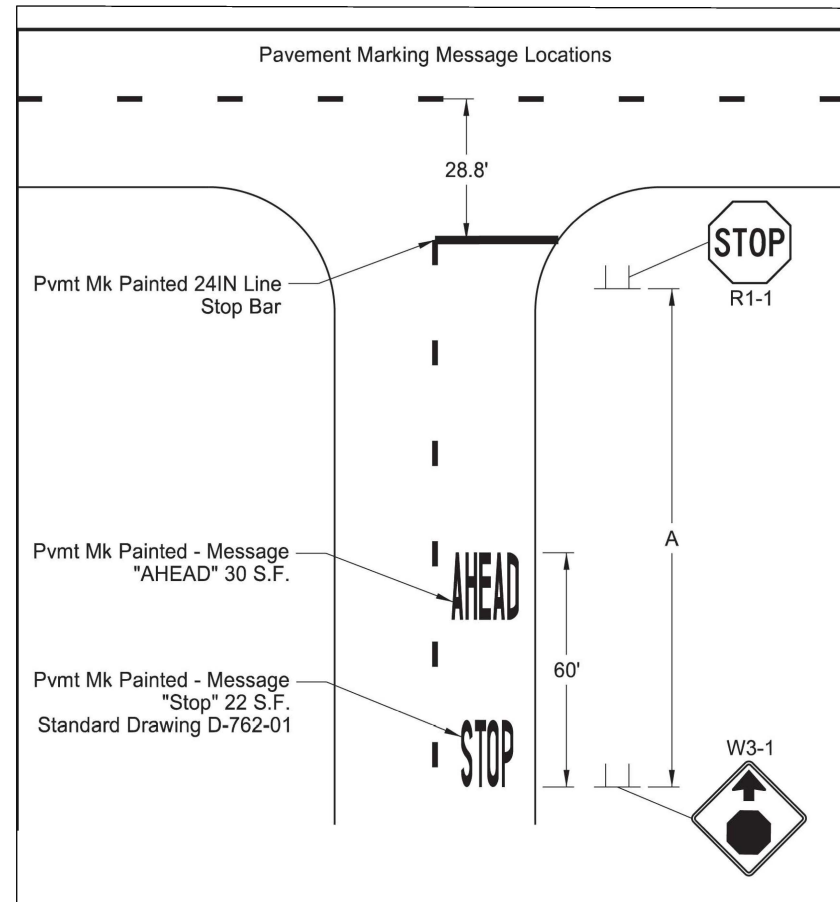

SPEC CODE	BID ITEM	QTY	UNIT
762 0103	PVMT MK PAINTED - MESSAGE		
	STOP - STA. 519+05 RT	22	SF
	AHEAD - STA. 519+55 RT	30	SF
762 0124	PVMT MK PAINTED 24IN LINE		
	CO RD 20 INTERSECTION (WEST SIDE)	14	LF
	NDSH 5 INTERSECTION	26	LF

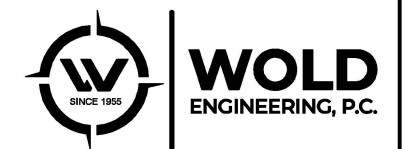
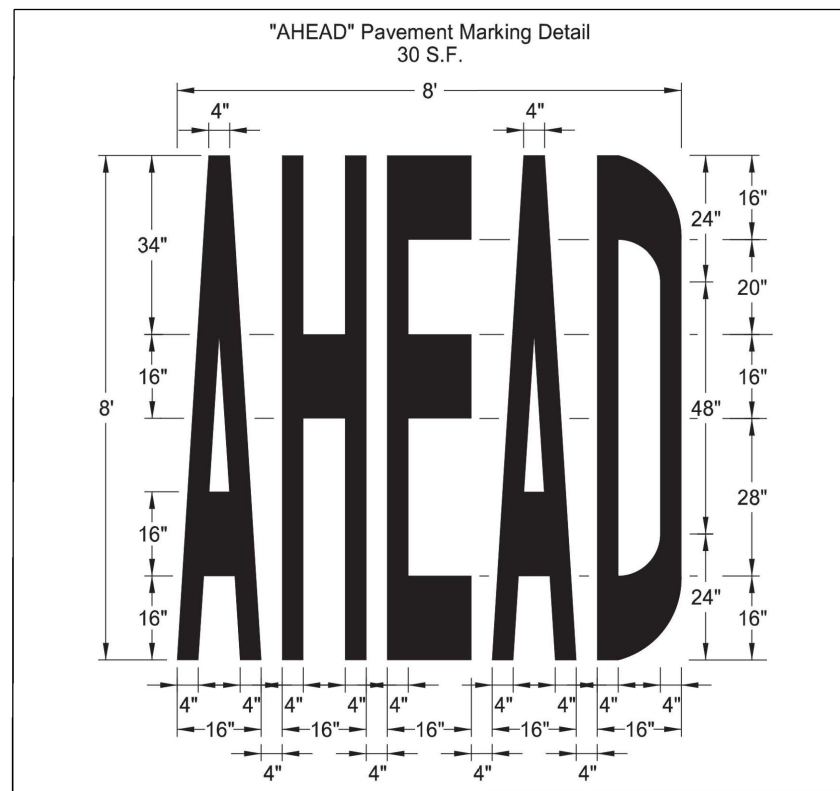

This document was originally issued and sealed by
 Jesse R. Brandvold,
 Registration Number
 PE-40107
 on 08/21/25 and the original document is stored at
 Wold Engineering, P.C.
 Bottineau, North Dakota

PAVEMENT MARKING
 PAINTED MESSAGE

NDDOT ABBREVIATIONS

D-101-1

? This is a special text character used in the labeling of existing features. It indicates a feature that has an unknown characteristic, potentially based on: lack of description, location accuracy or purpose.

Abn abandoned
 Abut abutment
 Adj adjusted
 Aggr aggregate
 Ahd ahead
 ARV air release valve
 Align alignment
 Al alley
 Alt alternate
 Alum aluminum
 ADA Americans with Disabilities Act
 & and
 Appr approach
 Approx approximate
 ACP asbestos cement pipe
 Asph asphalt
 AC asphalt cement
 Assmd assumed
 @ at
 Atten attenuation
 ATR automatic traffic recorder
 Ave Avenue
 Avg average
 ADT average daily traffic

Bk back
 BF back face
 Balc balcony
 B Wire barbed wire
 Barr barricade
 Btry battery
 BI beehive inlet
 Beg begin
 BG below grade
 BM bench mark
 Bkwy bikeway
 Bit bituminous
 Blk block
 BH bore hole
 Bot bottom
 Blvd Boulevard
 Bndry boundary
 Brkwy breakaway
 Br bridge
 Bldg building
 Bus. business
 BV butterfly valve
 Byp bypass

C Gdrl cable guardrail
 Calc calculate
 CIP cast iron pipe
 CB catch basin
 CRS cationic rapid setting
 C Gd cattle guard
 C To C center to center
 CL or ☉ centerline
 Ch chain
 Chnlk chain-link
 Ch Blk channel block
 Ch Ch channel change
 Chk check
 Chsid chiseled
 Cir circle
 Cl class
 Clnt clean-out
 Clr clear
 Cl&gr clearing & grubbing
 Comb. combination
 Coml commercial
 Compr compression
 CADD computer aided drafting & design
 Conc concrete
 CECB concrete erosion control blanket
 Cond conductor
 Const construction
 Cont continuous
 CSB continuous split barrel sample
 Contr contraction
 Contr contractor
 CP control point
 Coord coordinate
 Cor corner
 Corr corrected
 CAES corrugated aluminum end section
 CAP corrugated aluminum pipe
 CMES corrugated metal end section
 CMP corrugated metal pipe
 CPVCP corrugated poly-vinyl chloride pipe
 CSES corrugated steel end section
 CSFES corrugated steel flared end section
 CSP corrugated steel pipe
 CSTES corrugated steel traversable end section
 Co County
 Crse course
 Ct Court
 Xarm cross arm
 Xbuck cross buck
 Xsec cross sections
 Xing crossing
 Xrd crossroad
 Crn crown

Culv culvert
 C&G curb & gutter
 CI curb inlet
 CR curb ramp
 C cut
 Dd Ld dead load
 Defl deflection
 Defm deformed
 DInt delineate
 DIntr delineator
 Depr depression
 Desc description
 Det detail
 DWP detectable warning panel
 Dtr detour
 Dia or ø diameter
 Dir direction
 Dist distance
 DM disturbed material
 DB ditch block
 DG ditch grade
 Dbl double
 Dn down
 Dwg drawing
 Dr drive
 Drwy driveway
 DI drop inlet
 D dry density

Ea each
 Esmt easement
 E East
 EB Eastbound
 Elast elastomeric
 EL electric locker
 E Mtr electric meter
 Elec electric/al
 EDM electronic distance meter
 Elev or El elevation
 Ellipt elliptical
 Emb embankment
 Emuls emulsion/emulsified
 ES end section
 Engr engineer
 ESS environmental sensor station
 Eq equal
 Evgr evergreen
 Exc excavation
 Exst existing
 Exp expansion
 Expy Expressway
 E external of curve
 Extru extruded

FOS factor of safety
 Fed Federal
 FP feed point
 Fn fence
 Fn P fence post
 FO fiber optic
 FD field drive
 F fill
 FAA fine aggregate angularity
 FH fire hydrant
 Fl flange
 Flrd flared
 FES flared end section
 F Bcn flashing beacon
 FA flight auger sample
 FL flow line
 Ftg footing
 FM force main
 Fnd found
 Fdn foundation
 Frac fractional
 Frwy freeway
 Frt front
 FF front face
 F Disp fuel dispenser
 FFP fuel filler pipes
 FLS fuel leak sensor
 Furn furnish/ed

NORTH DAKOTA DEPARTMENT OF TRANSPORTATION	
07-01-14	
REVISIONS	
DATE	CHANGE
04-23-18	General Revisions
09-20-18	General Revisions
12-18-20	General Revisions
08-16-22	General Revisions



NDDOT ABBREVIATIONS

D-101-2

Galv	galvanized	Ln	lane	Obsc	obscure(d)	Qty	quantity
Gar	garage	Lg	large	Ocpd	occupied	Qtr	quarter
Gs L	gas line	Lat	latitude	Ocpy	occupy		
G Reg	gas line regulator	Lt	left	O/s	offset		
GMV	gas main valve	Lens	lenses	OC	on center	Rad or R	radius
G Mtr	gas meter	Lvl	level	C	one dimensional consolidation	RR	railroad
GSV	gas service valve	Lvng	leveling	OC	organic content	Rlwy	railway
GVP	gas vent pipe	Lht	light	Orig	original	Rsd	raised
GV	gate valve	LP	light pole	O To O	out to out	RC	rapid curing
Ga	gauge	Ltg	lighting	OD	outside diameter	Rec	record
Gov	government	Liq	liquid	OH	overhead	Recy	recycle
Grd	graded/grade	LL	liquid limit			RAP	recycled asphalt pavement
Gmd	ground	Loc	location			RPCC	recycled portland cement concrete
GWM	ground water monitor	Long.	longitude	PMT	pad mounted transformer	Ref	reference
Gdrl	guardrail	Lp	loop	Pg	pages	R Mkr	reference marker
Gtr	gutter	LD	loop detector	Pntd	painted	RM	reference monument
		Lum	luminaire	Pr	pair	RP	reference point
				Pnl	panel	Refl	reflectorized
H Plg	H piling			Pk	park	RCB	reinforced concrete box
Hdwl	headwall	Mb	mailbox	PSD	passing sight distance	RCES	reinforced concrete end section
Ht	height	ML	main line	Pvmt	pavement	RCFES	reinforced concrete flared end section
Hel	helical	MH	manhole	Ped	pedestal	RCP	reinforced concrete pipe
HDPE	high density polyethylene	Mkd	marked	Ped	pedestrian	RCPS	reinforced concrete pipe sewer
HM	high mast	Mkr	marker	PPP	pedestrian pushbutton post	RCTES	reinforced concrete traversable end section
HP	high pressure	Mkg	marking	Pen.	penetration	Reinf	reinforcement
HPS	high pressure sodium	MA	mast arm	Perf	perforated	Res	reservation
HTCG	high tension cable guardrail	Matl	material	Per.	perimeter	Res	residence
Hwy	highway	Max	maximum	Perm	permanent	Ret	retaining
Hor	horizontal	MC	meander corner	PL	pipeline	Rev	reverse
HBP	hot bituminous pavement	Meas	measure	Pl	place	Rt	right
HMA	hot mix asphalt	Mdn	median	P&P	plan & profile	R/W	right of way
Hyd	hydrant	MD	median drain	PL	plastic limit	Riv	river
Ph	hydrogen ion content	MC	medium curing	Pl or P _L	plate	Rd	road
		MGS	Midwest Guardrail System	Pt	point	Rdbd	road bed
		MM	mile marker	PE	polyethylene	Rdwy	roadway
Id	identification	MP	mile post	PVC	polyvinyl chloride	RWIS	roadway weather information system
Incl	inclinometer tube	Min	minimum	PCC	Portland Cement concrete	Rk	rock
IMH	inlet manhole	Misc	miscellaneous	PP	power pole	Rt	route
ID	inside diameter	Mon	monument	Preempt	preemption		
Inst	instrument	Mnd	mound	Prefab	prefabricated		
Intchg	interchange	Mtbl	mountable	Prfmd or Pref	performed		
Intmdt	intermediate	Mtd	mounted	Prep	preparation		
Intscn	intersection	Mtg	mounting	Press.	pressure		
Inv	invert	Mk	muck	PRV	pressure relief valve		
IP	iron pipe			Prestr	prestressed		
				Pvt	private		
				PD	private drive		
Jt	joint	Neop	neoprene	Prod.	production/produce		
Jct	junction	Ntwk	network	Prog	programmed		
		N	North	Prop.	property		
		NE	North East	Prop Ln	property line		
		NW	North West	Ppsd	proposed		
		NB	Northbound	PB	pull box		
		No. or #	number				

NORTH DAKOTA DEPARTMENT OF TRANSPORTATION	
07-01-14	
REVISIONS	
DATE	CHANGE
08-03-15	General Revisions
04-23-18	General Revisions
12-18-20	General Revisions
08-16-22	General Revisions



NDDOT ABBREVIATIONS

D-101-3

Salv	salvage(d)	Tel	telephone
San	sanitary sewer line	Tel B	Telephone Booth
Sec	section	Tel P	telephone pole
SL	section line	Tv	television
Sep	separation	Temp	temperature
Seq	sequence	Temp	temporary
Serv	service	TBM	temporary bench mark
Sht	sheet	T	thinwall tube sample
Shtng	sheeting	Ts	topsoil
Shldr	shoulder	Traf	traffic
Sw or Sdwk	sidewalk	TSCB	traffic signal control box
SD	sight distance	Tr	trail
SN	sign number	Transf	transformer
Sig	signal	Trans	transition
Sgl	single	TT	transmission tower
SRCP	slotted reinforced concrete pipe	TES	traversable end section
SC	slow curing	Trans	transverse
SS	slow setting	Trtd	treated
Sm	small	Trmt	treatment
S	South	Qc	triaxial compression
SE	South East	TERO	tribal employment rights ordinance
SW	South West	Tpl	triple
SB	Southbound	Typ	typical
Sp	spaces		
Spcl	special	Qu	unconfined compressive strength
SA	special assembly	Ugrnd	underground
SP	special provisions	Util	utility
G	specific gravity		
Spk	spike	VG	valley gutter
SB	split barrel sample	Vap	vapor
SH	sprinkler head	Vert	vertical
SV	sprinkler valve	VCP	vitrified clay pipe
Sq	square	Vol	volume
Stk	stake	VSFS	vehicle speed feedback sign
Std	standard		
N	standard penetration test	Wkwy	walkway
Std Specs	standard specifications	W	water content
Stm L	steam line	WGV	water gate valve
SEC	steel encased concrete	WL	water line
SMA	stone matrix asphalt	WM	water main
SSD	stopping sight distance	WMV	water main valve
SD	storm drain	W Mtr	water meter
St	street	WSV	water service valve
SPP	structural plate pipe	WW	water well
SPPA	structural plate pipe arch	Wrng	wearing
Str	structure	WIM	weigh in motion
Subd	subdivision	W	west
Sub	subgrade	WB	westbound
Sub Prep	subgrade preparation	Wrng	wiring
Ss	subsoil	W/	with
SS	supplement specification	W/o	without
Supp	supplemental	WC	witness corner
Surf	surfacing		
Surv	survey		
Sym	symmetrical		

NORTH DAKOTA DEPARTMENT OF TRANSPORTATION	
07-01-14	
REVISIONS	
DATE	CHANGE
08-03-15	General Revisions
04-23-18	General Revisions
12-18-20	General Revisions
08-16-22	General Revisions



08/16/22

NDDOT ABBREVIATIONS

D-101-4

MEASUREMENTS

ac acres
 A ampere
 Bd Ft board feet
 Cd candela
 cm centimeter
 C coulomb
 CF cubic feet
 m3 cubic meter
 m3/s cubic meters per second
 CY cubic yard
 CY/mi cubic yards per mile
 D or Deg degree
 F Fahrenheit
 F farad
 ft feet/foot
 Gal gallon
 G giga
 Ha hectare
 H henry
 Hz hertz
 hr hour(s)
 in inch
 J joule
 K kelvin
 kN kilo newton
 kPa kilo pascal
 kg kilogram
 kg/m3 kilogram per cubic meter
 km kilometer
 K Kip(s)
 LF linear foot
 L litre
 Lm lumen
 L sum lump sum
 Lx lux
 M Hr man hour
 M mega
 m meter
 m/s meters per second
 mi mile
 mL milliliter
 mm millimeter
 mm/hr millimeters per hour
 n nano
 N newton
 Pa pascal
 lb pounds
 sec seconds
 S siemens
 SF square feet
 km2 square kilometer
 m2 square meter
 SY square yard
 Sta Yd station yards
 SI Systems International

T tesla
 T/mi tons per mile
 V volt
 W watt
 Wb weber

SURVEY DESCRIPTIONS

Az azimuth
 Bs backsight
 Brg bearing
 BP Cap blue plastic cap
 BS both sides
 BC brass cap
 CS curve to spiral
 Eq equation
 E external of curve
 FS far side
 FB field book
 Fs foresight
 Geod geodetic
 GIS Geographical Information System
 GPS Global Positioning System
 HI height of instrument
 IM iron monument
 I Pn iron pin
 LS Land Surveyor (licensed)
 LSIT Land Surveyor In Training
 L length of curve
 LC long chord
 LB level book
 Mer meridian
 M mid ordinate of curve
 NGS National Geodetic Survey
 NS near side
 Obsn observation
 Off Loc office location
 OP Cap orange plastic cap
 PK Parker-Kalon nail
 P Cap plastic cap
 PP Cap pink plastic cap
 PCC point of compound curve
 PC point of curve
 PI point of intersection
 PRC point of reverse curvature
 PT point of tangent
 POC point on curve
 POT point on tangent
 RTP random traverse point
 Rge range
 RP Cap red plastic cap
 SC spiral to curve
 ST spiral to tangent
 Sta station
 SE superelevation
 Tan tangent
 T tangent (semi)
 TS tangent to spiral
 Twp township
 TB transit book
 TP traverse point
 TP turning point
 USC&G US Coast & Geodetic Survey
 USGS US Geologic Survey
 VC vertical curve
 WGS World Geodetic System
 YP Cap yellow plastic cap
 Z zenith

SOIL TYPES

Cl clay
 Cl F clay fill
 Cl Hvy clay heavy
 Cl Lm clay loam
 Co S coal slack
 C Gr coarse gravel
 CS coarse sand
 FS fine sand
 Gr gravel
 Lig Co lignite coal
 Lig Sl lignite slack
 Lm loam
 Rk rock
 Sd sand
 Sdy Cl sandy clay
 Sdy Cl Lm sandy clay loam
 Sdy Fl sandy fill
 Sdy Lm sandy loam
 Sc scoria
 Sh shale
 Si Cl silt clay
 Si Cl Lm silty clay loam
 Si Lm silty loam

NORTH DAKOTA DEPARTMENT OF TRANSPORTATION	
07-01-14	
REVISIONS	
DATE	CHANGE
12-18-20	Sheet Added - Continued from D-101-3



NDDOT UTILITY COMPANY AND ORGANIZATION ABBREVIATIONS

D-101-10

702COM 702 Communications
 ACCENT Accent Communications
 AGASSIZ WU Agassiz Water Users Incorporated
 AGC Associated General Contractors of America
 ALL PL Alliance Pipeline
 ALL SEAS WU All Seasons Water Users Association
 AMOCO PI Amoco Pipeline Company
 AMRDA HESS Amerada Hess Corporation
 AT&T AT&T Corporation
 B PAW Bear Paw Energy Incorporated
 BAKER ELEC Baker Electric
 BASIN ELEC Basin Electric Cooperative Incorporated
 BEK TEL Bek Communications Cooperative
 BELLE PL Belle Fourche Pipeline Company
 BLM Bureau of Land Management
 BNSF Burlington Northern Santa Fe Railway
 BOEING Boeing
 BRNS RWD Barnes Rural Water District
 BURK-DIV ELEC Burke-Divide Electric Cooperative
 BURL WU Burleigh Water Users
 CABLE ONE Cable One
 CABLE SERV Cable Services
 CAP ELEC Capital Electric Cooperative Incorporated
 CASS CO ELEC Cass County Electric Cooperative
 CASS RWU Cass Rural Water Users Incorporated
 CAV ELEC Cavalier Rural Electric Cooperative
 CBLCOM Cablecom Of Fargo
 CENEX PL Cenex Pipeline
 CENT PL WATER DIST Central Pipe Line Water District
 CENT PWR ELEC Central Power Electric Cooperative
 CENTURYLINK CenturyLink
 COE Corps of Engineers
 CONS TEL Consolidated Telephone
 CONT RES Continental Resource Inc
 CPR Canadian Pacific Railway
 D O E Department Of Energy
 DAK CARR Dakota Carrier Network
 DAK CENT TEL Dakota Central Telephone
 DAK RWD Dakota Rural Water District
 DGC Dakota Gasification Company
 DICKEY R NET Dickey Rural Networks
 DICKEY RWU Dickey Rural Water Users Association
 DICKEY TEL Dickey Telephone
 DNRR Dakota Northern Railroad
 DOME PL Dome Pipeline Company
 DVELEC Dakota Valley Electric Cooperative
 DVMW Dakota, Missouri Valley & Western
 ENBRDG Enbridge Pipelines Incorporated
 ENVENTIS Enventis Telephone
 EQUINOR Equinor Pipeline
 FALK MNG Falkirk Mining Company
 FHWA Federal Highway Administration
 G FKS-TRL WD Grand Forks-traill Water District
 GETTY TRD & TRAN Getty Trading & Transportation
 GLDN W ELEC Golden West Electric Cooperative
 GRGS CO TEL Griggs County Telephone
 GTR RAMSEY WD Greater Ramsey Water District

GT PLNS NAT GAS Great Plains Natural Gas Company
 HALS TEL Halstad Telephone Company
 IDEA1 Idea1
 INT-COMM TEL Inter-Community Telephone Company
 KANEB PL Kaneb Pipeline Company
 KEM ELEC Kem Electric Cooperative Incorporated
 KOCH GATH SYS Koch Gathering Systems Incorporated
 LKHD PL Lakehead Pipeline Company
 LNGDN RWU Langdon Rural Water Users Incorporated
 LWR YELL R ELEC Lower Yellowstone Rural Electric
 MCKNZ CON McKenzie Consolidated Telcom
 MCKNZ ELEC McKenzie Electric Cooperative
 MCKNZ WRD McKenzie County Water Resource District
 MCLEOD McLeod USA
 MCLN ELEC McLean Electric Cooperative
 MCLN-SHRDN R WAT McLean-Sheridan Rural Water
 MDU Montana-dakota Utilities
 MIDCO MidContinent Communications
 MIDSTATE TEL Midstate Telephone Company
 MINOT CABLE Minot Cable Television
 MINOT TEL Minot Telephone Company
 MISS VALL COMM Missouri Valley Communications
 MISS W W S Missouri West Water System
 MNKOTA PWR Minnkota Power
 MOR-GRAN-SOU ELEC Mor-gran-sou Electric Cooperative
 MOUNT-WILLI ELEC Mountrail-williams Electric Cooperative
 MRE LBTY TEL Moore & Liberty Telephone
 MUNICIPAL City Water And Sewer
 MUNICIPAL City Of '.....'
 N CENT ELEC North Central Electric Cooperative
 N VALL W DIST North Valley Water District
 ND PKS & REC North Dakota Parks And Recreation
 ND TEL North Dakota Telephone Company
 NDDOT North Dakota Department of Transportation
 NDSU SOIL SCI DEPT NDSU Soil Science Department
 NEMONT TEL Nemont Telephone
 NODAK R ELEC Nodak Rural Electric Cooperative
 NOON FRMS TEL Noonan Farmers Telephone Company
 NPR Northern Plains Railroad
 NSP Northern States Power
 NTH PRAIR RW Northern Prairie Rural Water Association
 NTHN BRDR PL Northern Border Pipeline
 NTHN PLNS ELEC Northern Plains Electric Cooperative Incorporated
 NTHWSTRN REF Northwestern Refinery Company
 NW COMM Northwest Communication Cooperation
 NWRWD Northwest Rural Water District
 ONEOK Oneok gas
 OSHA Occupational Safety and Health Administration
 OTTR TL PWR Otter Tail Power Company
 PAAP Plains All American Pipeline
 P L E M Prairielands Energy Marketing
 POLAR COM Polar Communications
 PVT ELEC Private Electric
 QWEST Qwest Communications
 R&T W SUPPLY R & T Water Supply Association

RED RIV COMM Red River Rural Communications
 RESVTN TEL Reservation Telephone
 ROBRTS TEL Roberts Company Telephone
 R-RIDER ELEC Roughrider Electric Cooperative
 RRVW Red River Valley & Western Railroad
 S CENT REG WD South Central Regional Water District
 S E W U South East Water Users Incorporated
 SCOTT CABLE Scott Cable Television Dickinson
 SHERDN ELEC Sheridan Electric Cooperative
 SHEYN VLY ELEC Sheyenne Valley Electric Cooperative
 SKYTECH Skyland Technologies Incorporated
 SLOPE ELEC Slope Electric Cooperative Incorporated
 SOURIS RIV TELCOM Souris River Telecommunications
 ST WAT COMM State Water Commission
 STATE LN WATER State Line Water Cooperative
 STER ENG Sterling Energy
 STUT RWU Stutsman Rural Water Users
 SW PL PRJ Southwest Pipeline Project
 T M C Turtle Mountain Communications
 TCI TCI of North Dakota
 TESORO GHG PLNS PL Tesoro High Plains Pipeline
 TRI-CNTY WU Tri-County Water Users Incorporated
 TRL CO RWU Traill County Rural Water Users
 UNTD TEL United Telephone
 UPPR SOUR WUA Upper Souris Water Users Association
 US SPRINT U.S. Sprint
 USAF MSL CABLE U.S.A.F. Missile Cable
 USFWS US Fish and Wildlife Service
 USW COMM U.S. West Communications
 VRNDRY ELEC Verendrye Electric Cooperative
 W RIV TEL West River Telephone Incorporated
 WAPA Western Area Power Administration
 WAWSA Western Area Water Supply Authority
 WEB W. E. B. Water Development Association
 WILLI RWA Williams Rural Water Association
 WILSTN BAS PL Williston Basin Interstate Pipeline Company
 WLSH RWD Walsh Water Rural Water District
 WOLVRTN TEL Wolverton Telephone
 XLENER Xcel Energy
 YSVR Yellowstone Valley Railroad

NORTH DAKOTA DEPARTMENT OF TRANSPORTATION	
07-01-14	
REVISIONS	
DATE	CHANGE
04-23-18	General Revisions
09-20-18	General Revisions
12-18-20	General Revisions
08-16-22	General Revisions



LINE STYLES

D-101-20

Existing Topography

- Existing Ground Void
- Existing Cemetery Boundary
- Existing Box Culvert Bridge
- Existing Concrete Surface
- Existing Drainage Structure
- Existing Gravel Surface
- Existing Riprap
- Existing Dirt Surface
- Existing Asphalt Surface
- Existing Tie Point Line
- Existing Railroad Centerline
- Existing Guardrail Cable
- Existing Guardrail Metal
- Existing Edge of Water
- Existing Fence
- Existing Railroad
- Existing Field Line
- Exst Flow
- Existing Curb
- Existing Valley Gutter
- Existing Driveway Gutter
- Existing Curb and Gutter
- Existing Mountable Curb and Gutter

- Existing 3-Cable w Posts
- Site Boundary
- Existing Berm, Dike, Pit, or Earth Dam
- Existing Ditch Block
- Existing Tree Boundary
- Existing Brush or Shrub Boundary
- Existing Retaining Wall
- Existing Planter or Wall
- Existing W-Beam Guardrail with Posts
- Existing Railroad Switch
- Gravel Pit - Borrow Area
- Existing Wet Area-Vegetation Break
- Existing High Tension Cable Guardrail
- Existing High Tension Cable Guardrail with Posts

Proposed Topography

- 3-Cable w Posts
- Flow
- Fence
- Remove Line
- Wall
- Retaining Wall (Plan View)
- W-Beam w Posts
- High Tension Cable Guardrail with Posts

Existing Utilities

- Existing Electrical
- Existing Fiber Optic Line
- Existing TV Fiber Optic
- Existing Gas Pipe
- Existing Overhead Utility Line
- Existing Power
- Existing Fuel Pipeline
- Existing Undefined Above Ground Pipe Line
- Existing Sanitary Sewer
- Existing Sanitary Force Main
- Existing Storm Drain
- Existing Storm Drain Force Main
- Existing Culvert
- Existing Telephone Line
- Existing TV Line
- Existing Water or Steam Line
- Existing Under Drain
- Existing Slotted Drain
- Existing Conduit
- Existing Conductor
- Existing Down Guy Wire Down Guy
- Existing Underground Vault or Lift Station

Proposed Utilities

- 24 Inch Pipe
- Reinforced Concrete Pipe
- Under Drain
- Edge Drain

Traffic Utilities

- Conductor
- Fiber Optic
- Existing Loop Detector
- Existing Double Micro Loop Detector
- Micro Loop Detector Double
- Existing Micro Loop Detector
- Micro Loop Detector
- Signal Head with Mast Arm
- Existing Signal Head with Mast Arm

Sign Structures

- Existing Overhead Sign Structure
- Existing Overhead Sign Structure Cantilever
- Overhead Sign Structure Cantilever

NORTH DAKOTA DEPARTMENT OF TRANSPORTATION	
07-01-14	
REVISIONS	
DATE	CHANGE
09-23-16	Added and Revised Items, Organized by Functional Groups
12-18-20	General Revisions

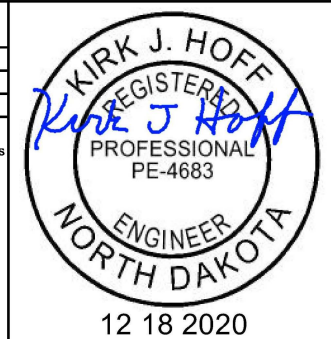

LINE STYLES

D-101-21

Right Of Way

- Easement
- Existing Easement
- Right of Way
- Existing Right of Way
- Existing Right of Way Railroad
- Existing Right of Way Not State Owned
- Existing Government Lot Line
- Existing Adjacent Block Lines
- Existing Adjacent Lot Lines
- Existing Adjacent Property Line
- Existing Adjacent Subdivision Lines
- Sight Distance Triangle Line
- Dimension Leader

Boundary Control

- ////// Existing City Corporate Limits or Reservation Boundary
- Existing State or International Line
- Existing Township
- Existing County
- Existing Section Line
- Existing Quarter Section Line
- Existing Sixteenth Section Line
- Existing Centerline
- Tangent Line

Cross Sections and Typical

- Existing Ground
- Existing Topsoil (Cross Section View)
- void - void - void - v Existing Ground Void (Not Surveyed)
- Existing Concrete
- Existing Aggregate (Cross Section View)
- Existing Curb and Gutter (Cross Section View)
- Existing Asphalt (Cross Section View)
- Existing Reinforcement Rebar

Geotechnical

- D ----- D ----- Geotextile Fabric Type D
- Geo ----- Geo ----- Geogrid
- R ----- R ----- Geotextile Fabric Type R
- R ----- R ----- Geotextile Fabric Type R1
- RR ----- RR ----- Geotextile Fabric Type RR
- S ----- S ----- Geotextile Fabric Type S

Countours

- Depression Contours
- Supplemental Contour

Profile

- Subgrade, Subcut or Ditch Grade
- Topsoil Profile

Striping

- Centerline Pavement Marking
- ===== Barrier with Centerline Pavement Marking
- ===== Barrier Pavement Marking
- - - - - Stripe 4 IN Dotted Extension White
- - - - - Stripe 8 IN Dotted Extension White
- - - - - Stripe 8 IN Lane Drop

Pavement Joints

- ===== Doweled Joint
- + + + + + Tie Bar 30 Inch 4 Foot Center to Center
- + + + + + Tie Bar 18 Inch 3 Foot Center to Center
- + + + + + Tie Bar at Random Spacing

Bridge Details

- Small Hidden Object
- Large Hidden Object
- Phantom Object
- Existing Conditions Object
- Centerline Main
- Centerline Secondary
- Excavation Limits
- Proposed Ground
- ===== Sheet Piling

Erosion Control

- Limits of Const Transition Line
- Bale Check
- Rock Check
- s ----- s ----- Floating Silt Curtain
- SF ----- SF ----- Silt Fence
- Excavation Limits
- Fiber Rolls

Environmental

- Wetland Mitigation
- Existing Wetland Easement USFWS
- Existing Wetland Jurisdictional
- Existing Wetland
- Tree Row

NORTH DAKOTA DEPARTMENT OF TRANSPORTATION	
07-01-14	
REVISIONS	
DATE	CHANGE
09-23-16	Added and Revised Items, Organized by Functional Groups General Revisions
12-18-20	



SYMBOLS



- Alignment Data Point
- Alignment Monument
- Spot Elevation
- Existing Miscellaneous Spot
- Existing Access Control Arrow
- Existing Benchmark
- Reset USGS Marker
- Iron Monument Found
- Iron Pin R/W Monument
- Property Corner
- Iron Pin Reference Monument
- Right of Way Marker (Exst, Ppsd, Reset)
- Existing Federal Reference Corner
- Existing Section Corner (Full, Quarter, Sixteenth, Meander)
- Existing Witness Corner
- Existing Control Point (CP, GPS-RTK, TRI)
- Existing Traverse PI Aerial Panel
- Existing Reference Marker Point NGS
- Existing EFB Misc

- Existing Bush or Shrub
- Existing Large Evergreen Tree
- Existing Small Evergreen Tree
- Existing Large Tree
- Existing Small Tree
- Existing Tree Trunk
- Cairn or Stone Circle
- Existing Artifact
- Existing Satellite Dish
- Existing Weather Station
- Existing Windmill or Tower
- Reinforced Pavement

- Continuous Split Barrel Sample
- Flight Auger Sample
- Split Barrel Sample
- Thinwall Tube Sample
- Standard Penetration Test
- Inclinometer Tube
- Excavation Unit
- Existing Ground Water Well Bore Hole

NORTH DAKOTA DEPARTMENT OF TRANSPORTATION	
07-01-14	
REVISIONS	
DATE	CHANGE
12-18-20	General Revisions

KIRK J. HOFF
REGISTERED
PROFESSIONAL
PE-4683
ENGINEER
NORTH DAKOTA
12 18 2020

SYMBOLS

D-101-32

	Existing Luminaire		High Mast Light Standard 3 Luminaire (Exst, Ppsd)		Existing Traffic Signal Standard
	Luminaire LED		High Mast Light Standard 4 Luminaire (Exst, Ppsd)		Pull Box (Exst-Ppsd-Undefined)
	Existing Light Standard Luminaire		High Mast Light Standard 5 Luminaire (Exst, Ppsd)		Intelligent Transportation Pull Box (Exst, Ppsd)
	Relocate Light Standard		High Mast Light Standard 6 Luminaire (Exst, Ppsd)		Transformer (Exst, Ppsd)
	Light Standard Light LED Luminaire		High Mast Light Standard 7 Luminaire (Exst, Ppsd)		Power Pole (Exst-Ppsd-with Transformer)
	Light Standard 35 Watt High Pressure Sodium Vapor Luminaire		High Mast Light Standard 8 Luminaire (Exst, Ppsd)		Wood Pole (Exst, Ppsd)
	Light Standard 50 Watt High Pressure Sodium Vapor Luminaire		High Mast Light Standard 9 Luminaire (Exst, Ppsd)		Pedestrian Push Button Post (Exst, Ppsd)
	Light Standard 70 Watt High Pressure Sodium Vapor Luminaire		High Mast Light Standard 10 Luminaire (Exst, Ppsd)		Existing Pole
	Light Standard 100 Watt High Pressure Sodium Vapor Luminaire		Overhead Sign Structure Load Center (Exst, Ppsd)		Existing Telephone Pole
	Light Standard 150 Watt High Pressure Sodium Vapor Luminaire		Traffic Signal Controller (Exst, Ppsd)		Existing Post
	Light Standard 200 Watt High Pressure Sodium Vapor Luminaire		Pad Mounted Traffic Signal Controller (Exst, Ppsd)		Connection Conductor (Ground, Neutral, Phase 1, Phase 2)
	Light Standard 250 Watt High Pressure Sodium Vapor Luminaire		Flashing Beacon (Exst, Ppsd)		
	Light Standard 310 Watt High Pressure Sodium Vapor Luminaire		Concrete Foundation (Exst, Ppsd)		
	Light Standard 400 Watt High Pressure Sodium Vapor Luminaire		Pipe Mounted Flasher (Exst, Ppsd)		
	Light Standard 700 Watt High Pressure Sodium Vapor Luminaire		Pad Mounted Feed Point (Exst, Ppsd)		
	Light Standard 1000 Watt High Pressure Sodium Vapor Luminaire		Pipe Mounted Feed Point with Pad (Exst, Ppsd)		
	Emergency Vehicle Detector		Pole Mounted Feed Point (Exst, Ppsd)		
	Video Detection Camera		Junction Box (Exst, Ppsd)		
			Existing Pedestrian Head with Number		
			Existing Signal Head		
			Pole Mounted Head		
			Existing Lighting Standard Pole		

NORTH DAKOTA DEPARTMENT OF TRANSPORTATION	
07-01-14	
REVISIONS	
DATE	CHANGE
12-18-20	General Revisions

KIRK J. HOFF
REGISTERED
PROFESSIONAL
ENGINEER
NORTH DAKOTA
PE-4683

12 18 2020

BREAKAWAY SYSTEMS FOR CONSTRUCTION ZONE SIGNS

D-704-7

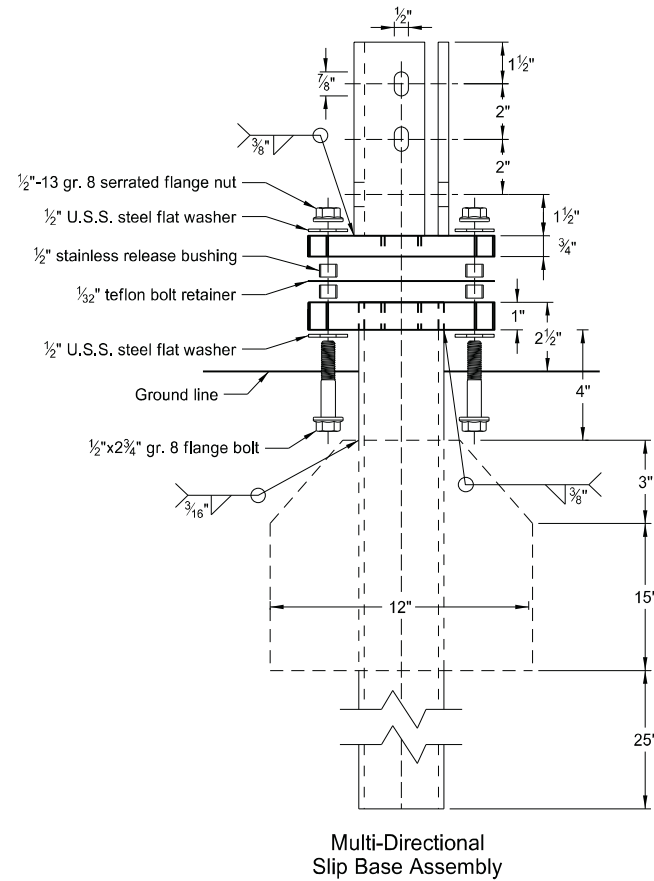

Perforated Tube

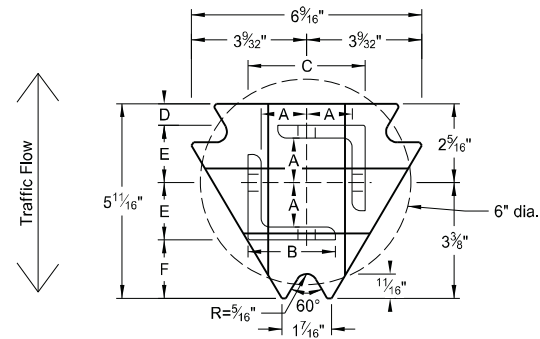
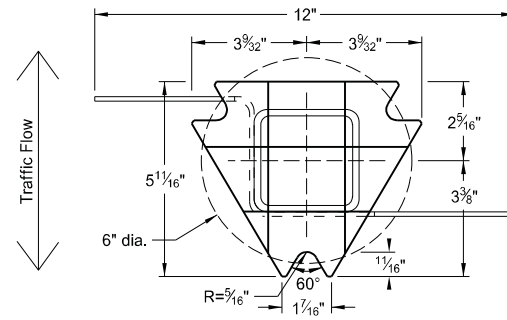
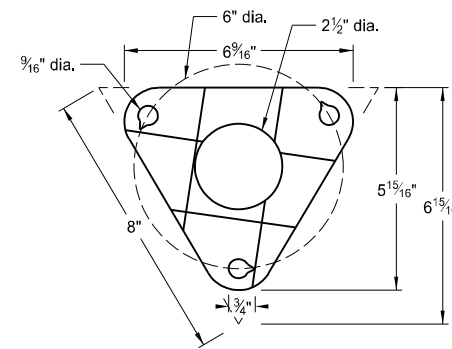

Plate - ASTM A572 grade 50
Angle Receiver - 2 1/2"x2 1/2"x3/8" ASTM A36 structural angle



Tube - 3"x3"x7 gauge ASTM A500 grade B tube
Stabilizing Wing - 7 gauge H.R.P.O. ASTM A1011
Plate - ASTM A572 grade 50



Bolt Retainer - 1/2" Reprocessed Teflon

Notes:

1. Torque slip base bolts as specified by manufacturer.
2. Use anchor with 43.9 KSI yield strength and 59.3 KSI tensile strength.
3. Provide 4" vertical clearance for anchor or breakaway base. Measure the 4"x60" measurement above and below post location and back and ahead of post.
4. In concrete sidewalk, use same anchor without wings.
5. Provide more than 7' between the first and fourth posts of a four post sign.

Telescoping Perforated Tube

Number of Posts	Post Size in.	Wall Thickness Gauge	Sleeve Size in.	Wall Thickness Gauge	Slip Base	Anchor Size without Slip Base in.
1	2	12			No	2 1/4
1	2 1/4	12			No	2 1/2
1	2 1/2	12			(A)	3
1	2 1/2	10			Yes	
1	2 1/4	12	2	12	Yes	
1	2 1/2	12	2 1/4	12	Yes	
2	2	12			No	2 1/4
2	2 1/4	12			No	2 1/2
2	2 1/2	12			Yes	
2	2 1/2	12			Yes	
2	2 1/4	10	2	12	Yes	
3 & 4	2 1/2	12			Yes	
3 & 4	2 1/2	10			Yes	
3 & 4	2 1/2	12	2 1/4	12	Yes	
3 & 4	2 1/4	12	2	12	Yes	
3 & 4	2 1/2	10	2 3/16	10	Yes	

Properties of Telescoping Perforated Tube

Tube Size in.	Wall Thickness in.	U.S. Standard Gauge	Weight per Foot lbs.	Moment of Inertia in. ⁴	Cross Sec. Area in. ²	Section Modulus in. ³
1 1/2 x 1 1/2	0.105	12	1.702	0.129	0.380	0.172
2 x 2	0.105	12	2.416	0.372	0.590	0.372
2 1/4 x 2 1/4	0.105	12	2.773	0.561	0.695	0.499
2 3/16 x 2 3/16	0.135	10	3.432	0.605	0.841	0.590
2 1/2 x 2 1/2	0.105	12	3.141	0.804	0.803	0.643
2 1/2 x 2 1/2	0.135	10	4.006	0.979	1.010	0.785

Top Post Receiver Data Table

Square Post Sizes (B)	A	B	C	D	E	F
2 3/16"x10 ga.	1 3/64"	2 1/2"	3 1/32"	2 5/32"	1 33/64"	1 7/8"
2 1/2"x10 ga.	1 3/32"	2 1/2"	3 5/16"	5/8"	1 21/32"	1 3/4"

(A) Use breakaway base when support is placed in weak soils. Engineer determines if soils are weak.

(B) For additional wind load, insert the 2 3/16"x10 ga. into 2 1/2"x10 ga.

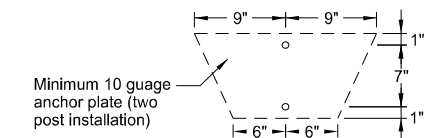
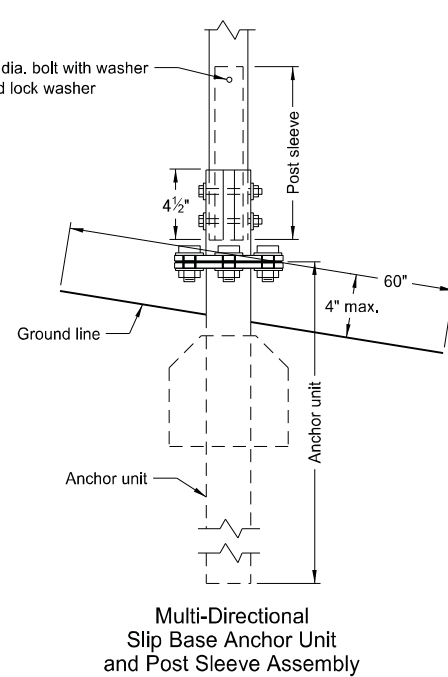
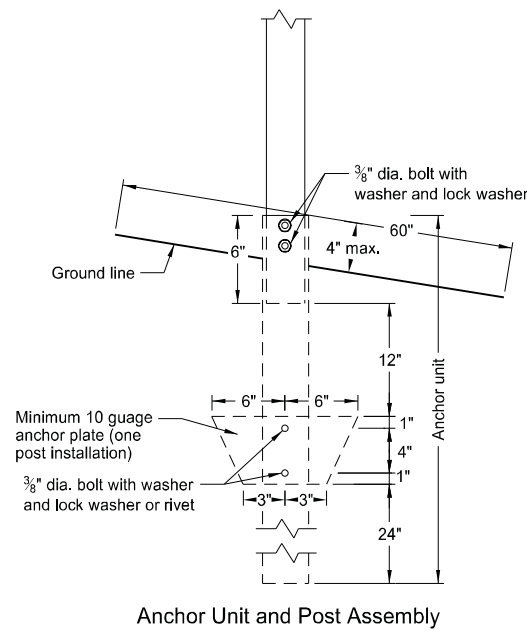

NORTH DAKOTA DEPARTMENT OF TRANSPORTATION	
2-28-14	
REVISIONS	
DATE	CHANGE
9-27-17	Updated to active voice
10-03-19	New Design Engr PE Stamp
8-01-24	Electronic Stamp/Signature



08/01/24

BREAKAWAY SYSTEMS FOR CONSTRUCTION ZONE SIGNS

U-Channel Post

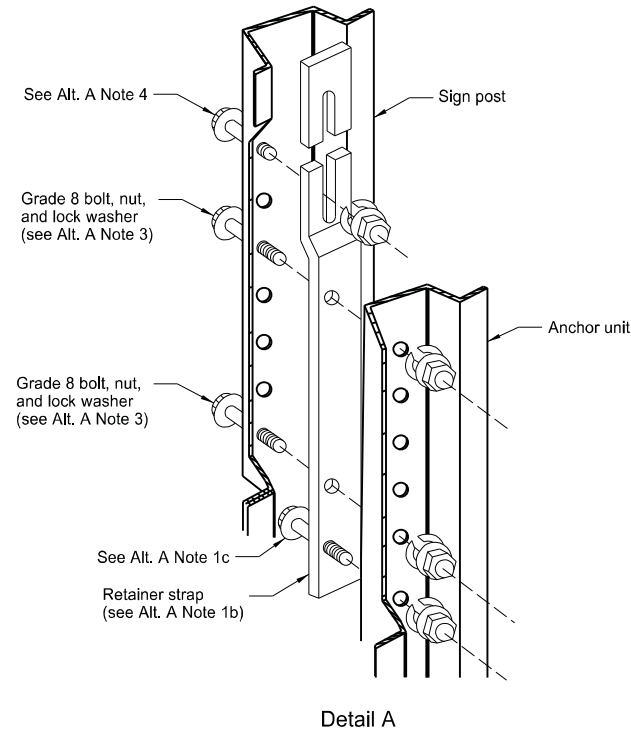

Detail A

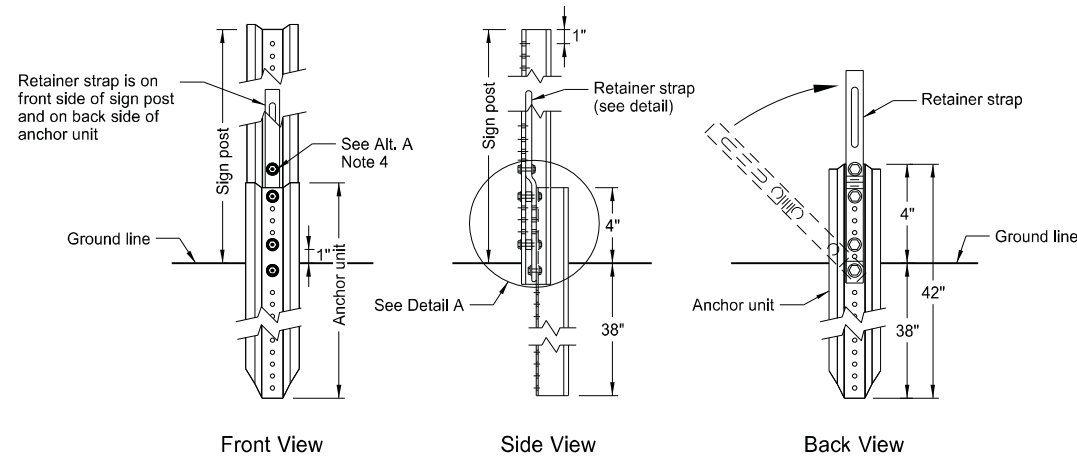

Front View

Side View

Back View

Breakaway U-Channel Detail Alternate A

Install a maximum of 2 posts within 7'.

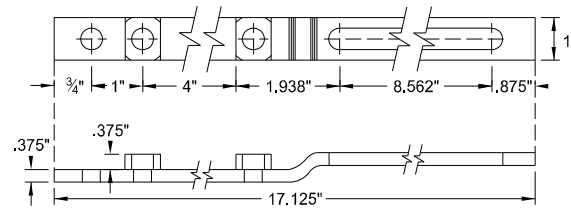

Retainer Strap Detail

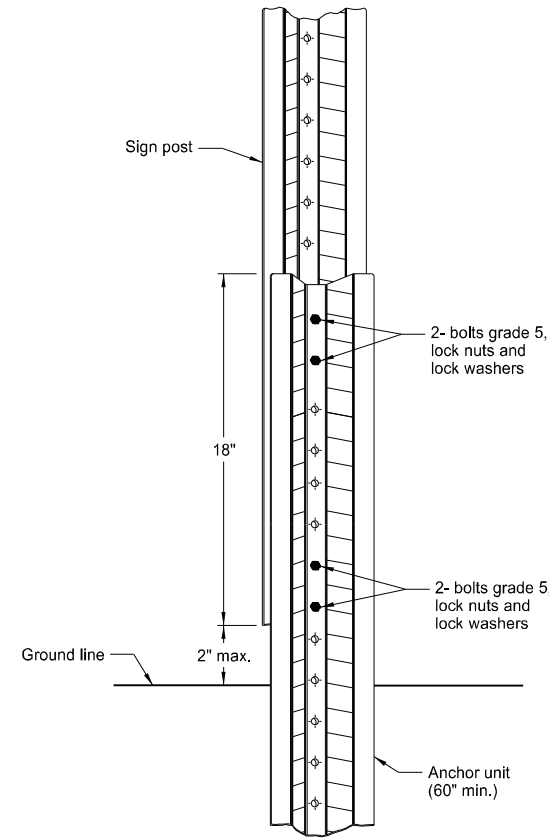

Breakaway U-Channel Splice Detail Alternate B (2.5 and 3 lb/ft)

Install a maximum of 3 posts within 7'.

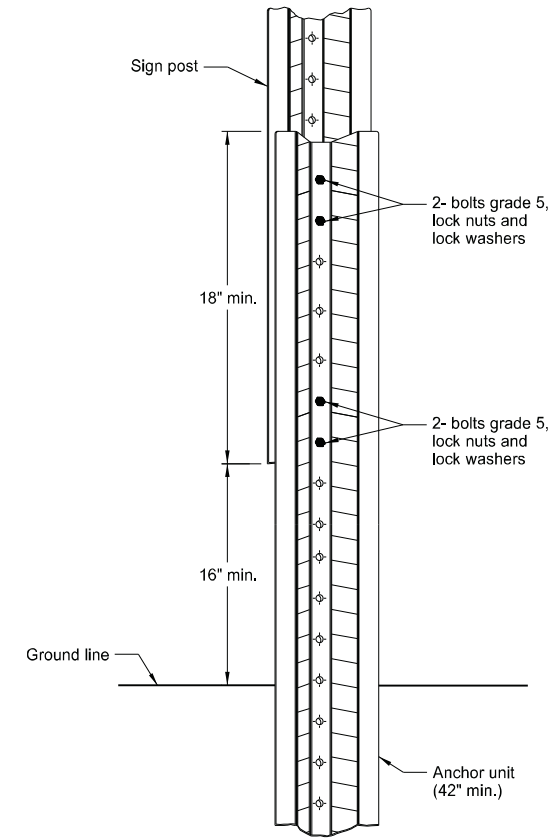

Breakaway U-Channel Splice Detail Alternate C (2.5 and 3 lb/ft)

Install a maximum of 3 posts within 7'.

Alternate A Steps of Installation:

1. a) Drive anchor unit to within 12" of ground level.
b) Establish proper assembly by lining up bottom hole of retainer strap with 6th hole from the top of the anchor unit.
c) Assemble strap to back of anchor unit using 5/16"x2" bolt, lock washer and nut.
d) Rotate strap 90° to left.
2. a) Drive anchor unit to 4" above ground.
b) Rotate strap to vertical position.
3. a) Place 5/16"x2" bolt, lock washer and nut in bottom of sign post to facilitate alignment of sign post with proper hole in anchor unit.
b) Alternately tighten two connector bolts.
4. Complete assembly by tightening 5/16"x2" bolt (this fastens sign post to retainer strap).
5. Properly nest base post, strap, and sign post. Proper nesting occurs when all flat surfaces of the base post, strap, and sign post at the bolts have full contact across the entire width.

NORTH DAKOTA DEPARTMENT OF TRANSPORTATION	
2-28-14	
REVISIONS	
DATE	CHANGE
9-27-17	Updated to active voice
10-03-19	New Design Engr PE Stamp
8-01-24	Electronic Stamp/Signature



08/01/24

CONSTRUCTION SIGN DETAILS
TERMINAL AND GUIDE SIGNS

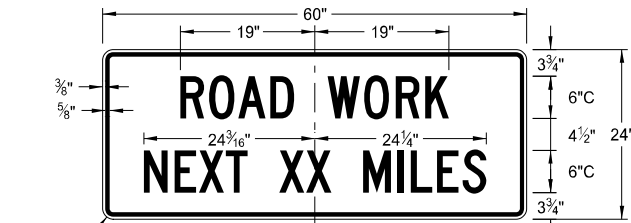

G20-1-60
Legend: black (non-refl)
Background: orange

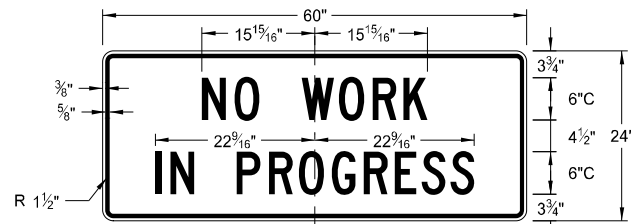

G20-1b-60
Legend: black (non-refl)
Background: orange

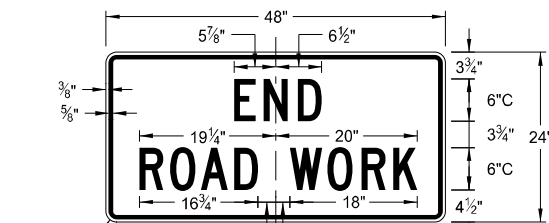

G20-2-48
Legend: black (non-refl)
Background: orange



G20-4b-36
Legend: black (non-refl)
Background: orange

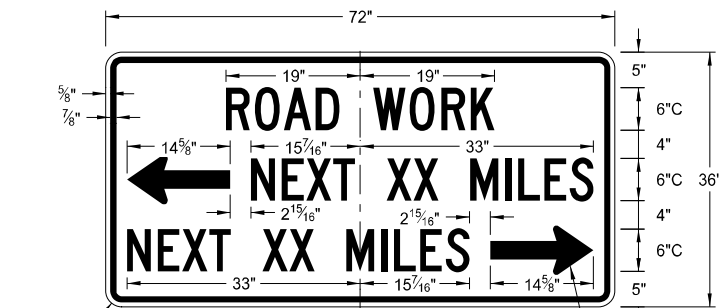

G20-50a-72
Legend: black (non-refl)
Background: orange

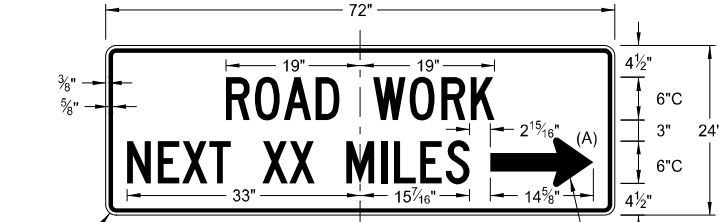

G20-52a-72
Legend: black (non-refl)
Background: orange

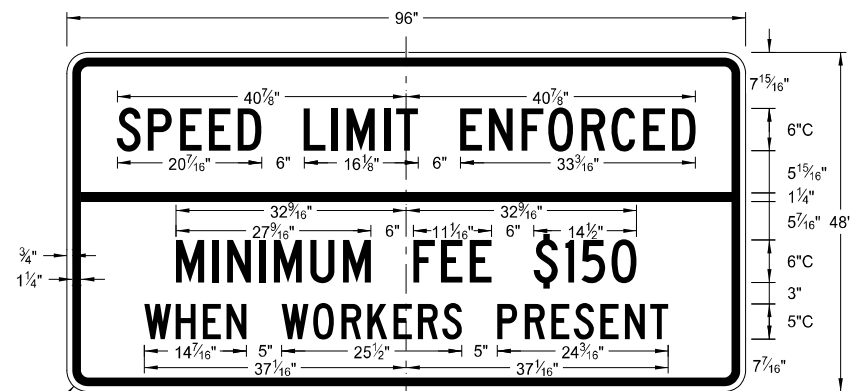

G20-55-96
Legend: black (non-refl)
Background: orange

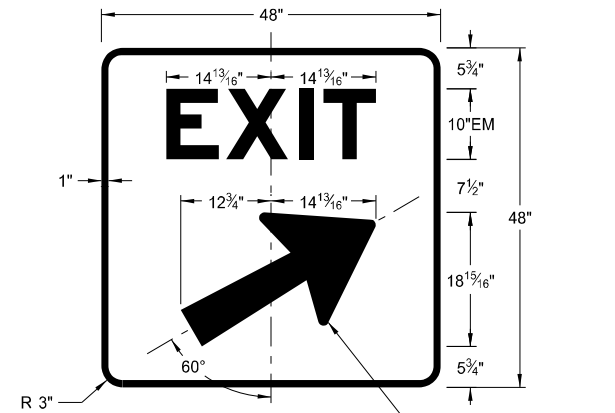

E5-1(L or R)-48
Legend: white
Background: green (orange optional)

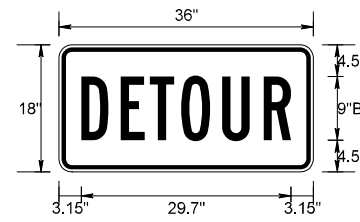

M4-8-36
Legend: black (non-refl)
Background: orange

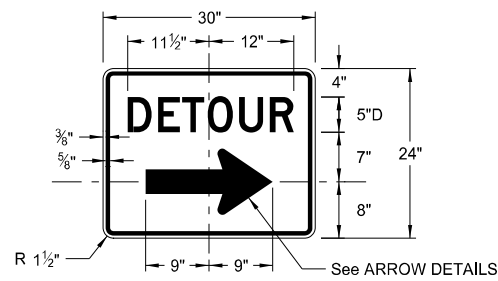

M4-9(L or R)-30 & M4-9-30
Legend: black (non-refl)
Background: orange

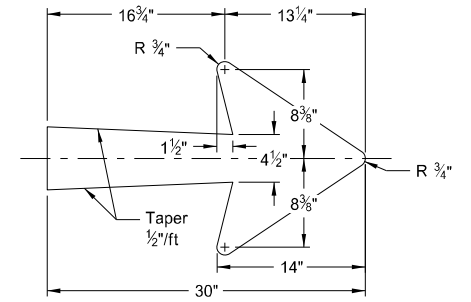

E5-1-48

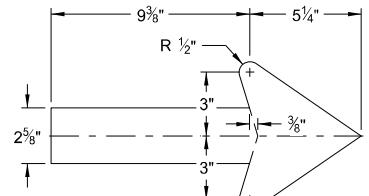

G20-50a-72
G20-52a-72

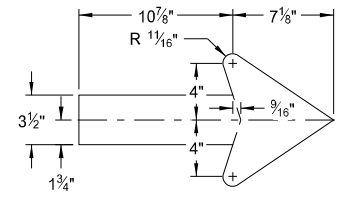

M4-9(L or R)-30
Right or Left

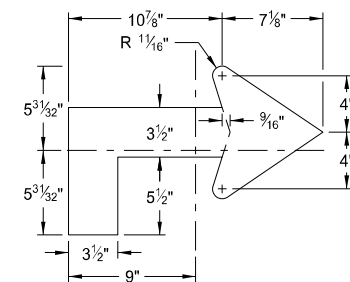

M4-9(L or R)-30
Advanced Right or Left

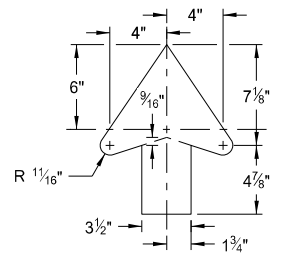

M4-9-30
Straight

ARROW DETAILS

NOTES:

(A) Arrow may be right or left of the legend to indicate construction to the right or left.

NORTH DAKOTA DEPARTMENT OF TRANSPORTATION	
8-13-13	
REVISIONS	
DATE	CHANGE
08-17-17	Added sign & background color
10-03-19	New Design Engineer PE Stamp
08-01-24	Electronic Stamp/Signature
06-30-25	Legislative Changes



CONSTRUCTION SIGN DETAILS
REGULATORY SIGNS

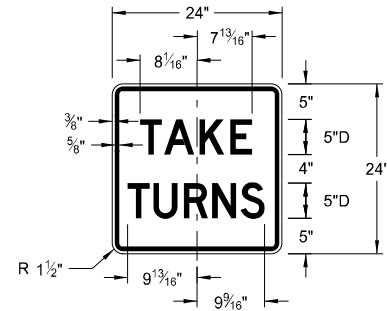

R1-50P-24
Legend: black (non-refl)
Background: white

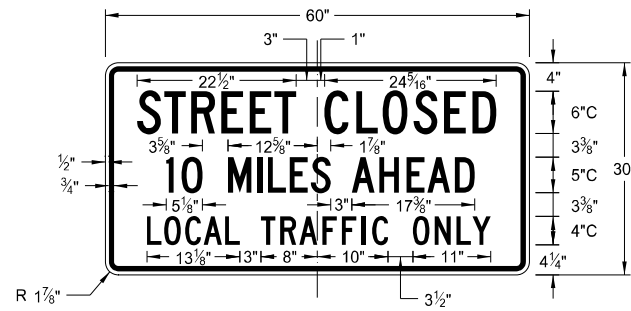

R11-3c-60
Legend: black (non-refl)
Background: white

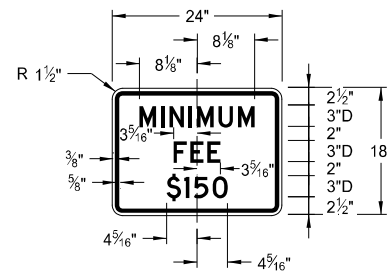

R2-1aP-24
Legend: black (non-refl)
Background: white

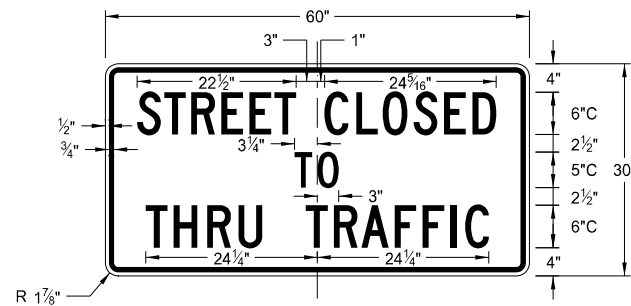

R11-4a-60
Legend: black (non-refl)
Background: white

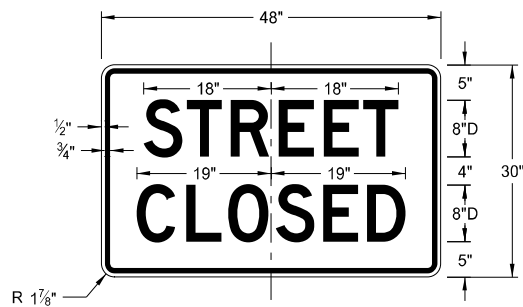

R11-2a-48
Legend: black (non-refl)
Background: white

NORTH DAKOTA DEPARTMENT OF TRANSPORTATION	
8-13-13	
REVISIONS	
DATE	CHANGE
08-17-17	Revised sign number
10-03-19	New Design Engineer PE Stamp
08-01-24	Electronic Stamp/Signature
06-30-25	Legislative Changes



CONSTRUCTION SIGN DETAILS
WARNING SIGNS

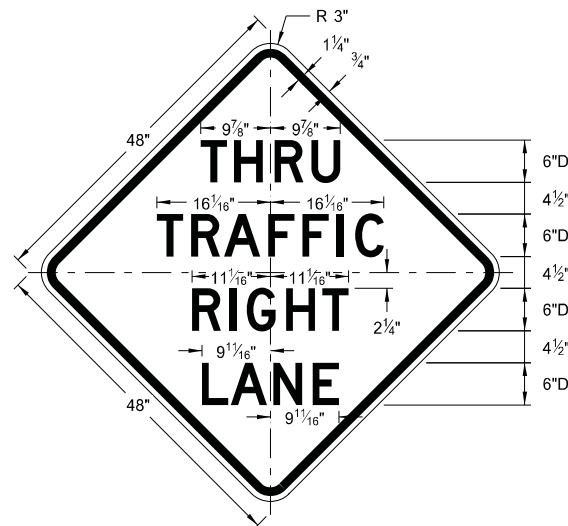

W5-8-48
Legend: black (non-refl)
Background: orange

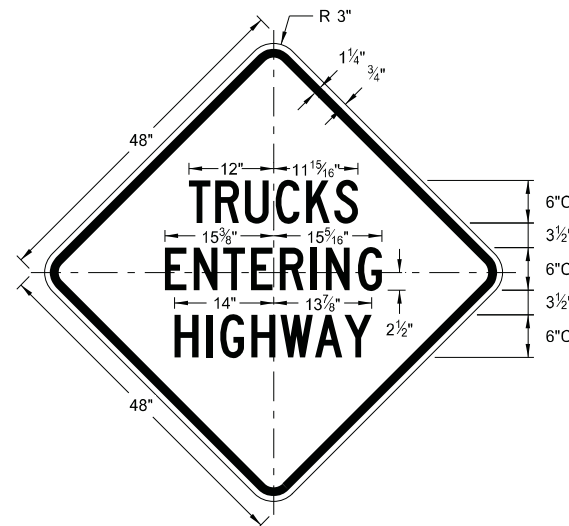

W8-53-48
Legend: black (non-refl)
Background: orange

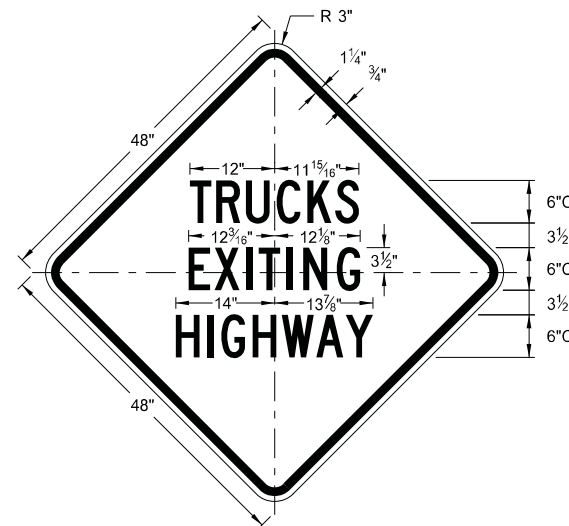

W8-56-48
Legend: black (non-refl)
Background: orange

WORD	LETTER SPACING
AHEAD	Standard
200 FT	Standard
350 FT	Standard
500 FT	Standard
1000 FT	Reduce 40%
1500 FT	Reduce 40%
1/2 MILE	Reduce 50%
1 MILE	Standard

* DISTANCE MESSAGES

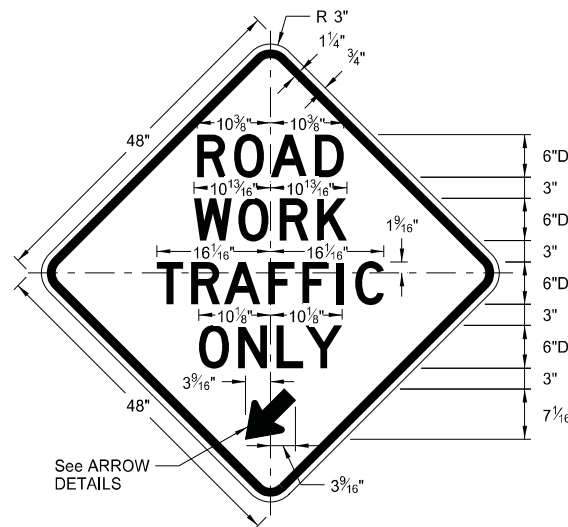

W5-9-48
Legend: black (non-refl)
Background: orange

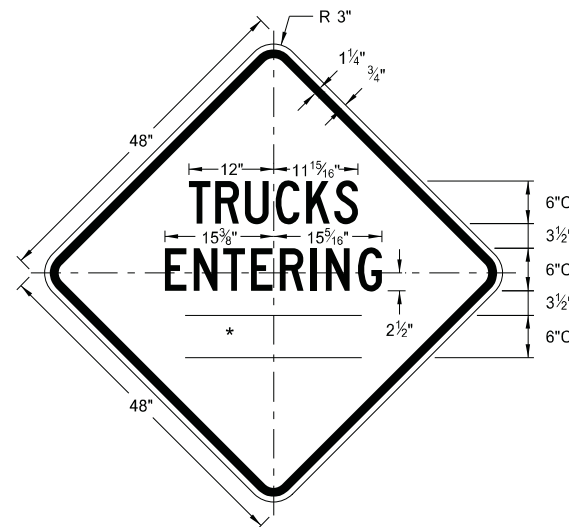

W8-54-48
Legend: black (non-refl)
Background: orange

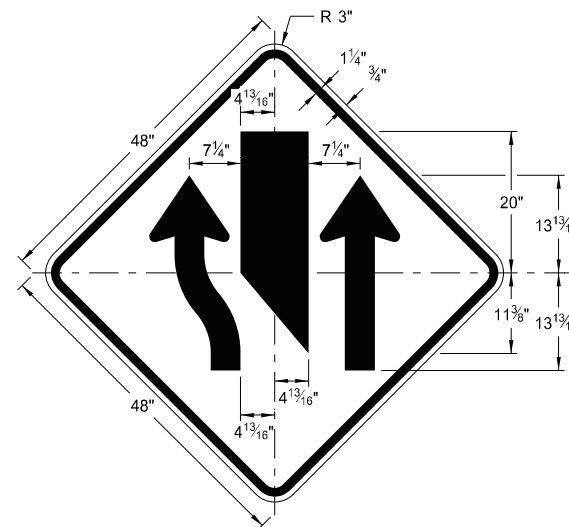

W9-3a-48
Legend: black (non-refl)
Background: orange

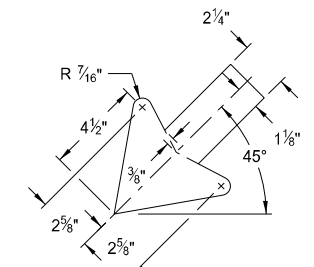

W5-9-48

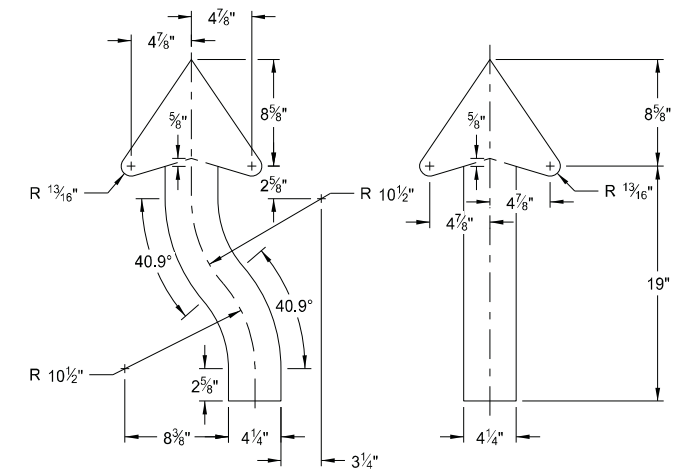

W9-3a-48

ARROW DETAILS

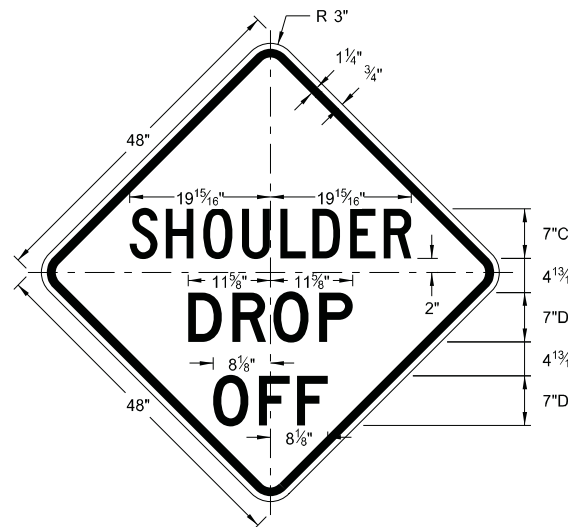

W8-9a-48
Legend: black (non-refl)
Background: orange

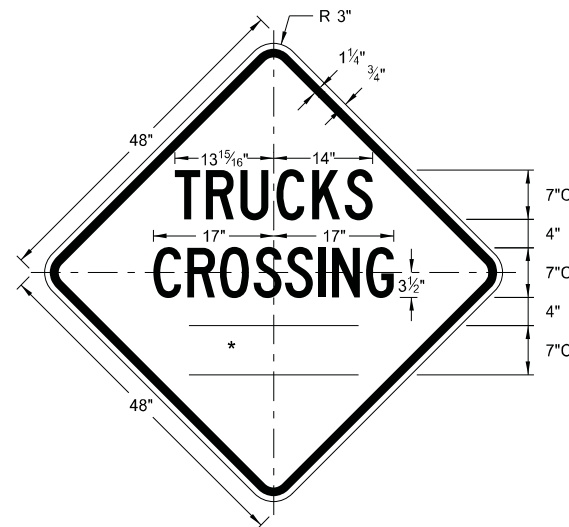

W8-55-48
Legend: black (non-refl)
Background: orange

NORTH DAKOTA DEPARTMENT OF TRANSPORTATION	
8-13-13	
REVISIONS	
DATE	CHANGE
8-17-17	Updated sign number
5-31-18	Revised sign and arrow details
10-03-19	New Design Engineer PE Stamp
8-01-24	Electronic Stamp/Signature



08/01/24

CONSTRUCTION SIGN DETAILS
WARNING SIGNS

WORD	LETTER SPACING
AHEAD	Standard
200 FT	Standard
350 FT	Standard
500 FT	Standard
1000 FT	Reduce 40%
1500 FT	Reduce 40%
½ MILE	Reduce 50%
1 MILE	Standard

* DISTANCE MESSAGES

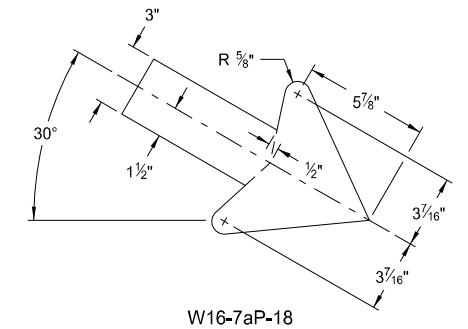

W16-7aP-18

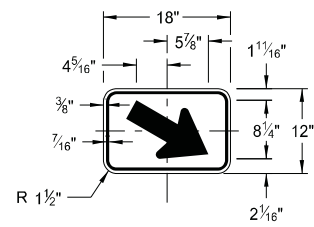

W16-7aP-18
Legend: black (non-refl)
Background: orange

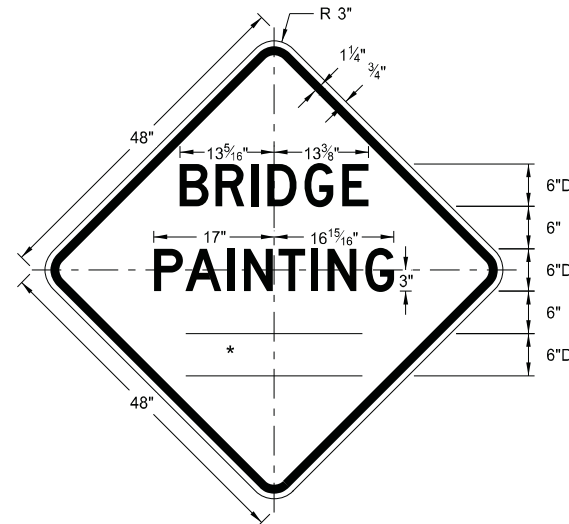

W21-50-48
Legend: black (non-refl)
Background: orange

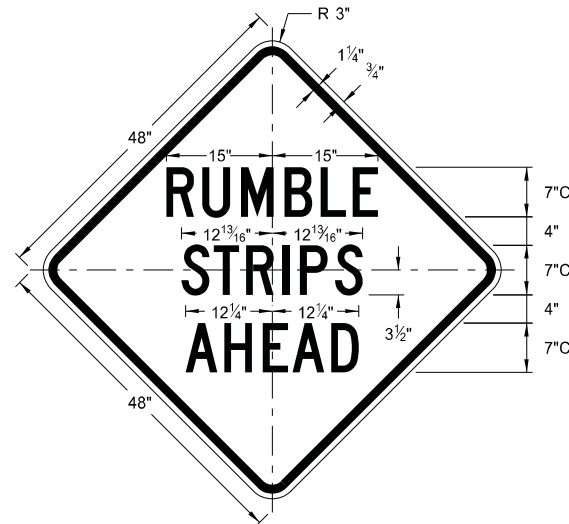

W21-53-48
Legend: black (non-refl)
Background: orange

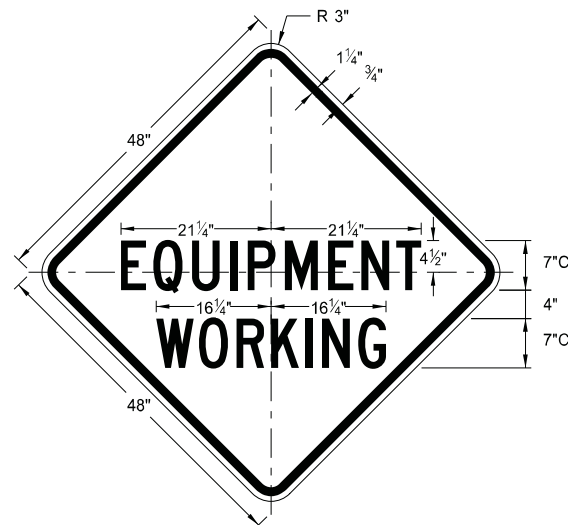

W20-51-48
Legend: black (non-refl)
Background: orange

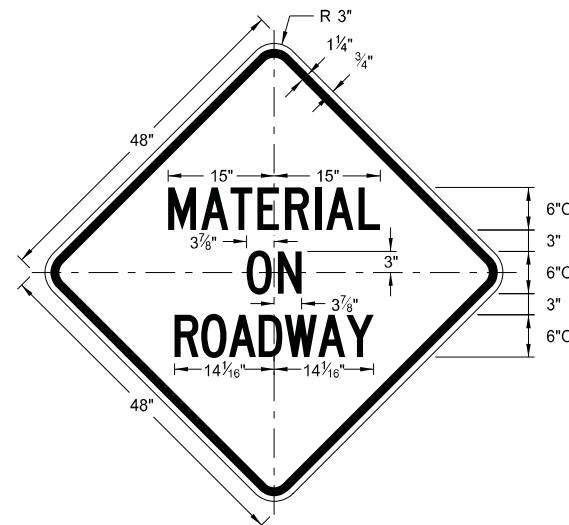

W21-51-48
Legend: black (non-refl)
Background: orange

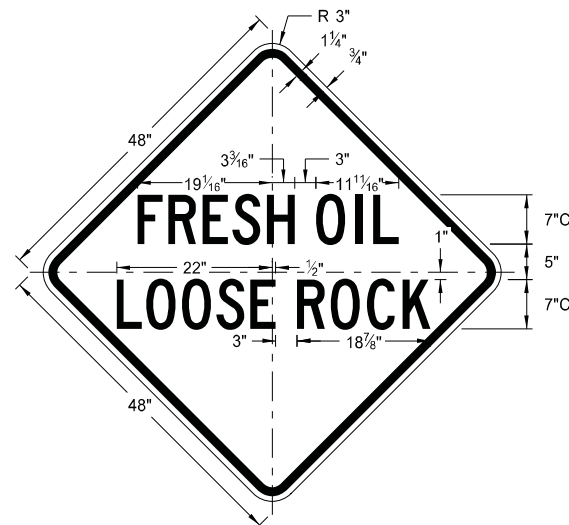

W22-8-48
Legend: black (non-refl)
Background: orange

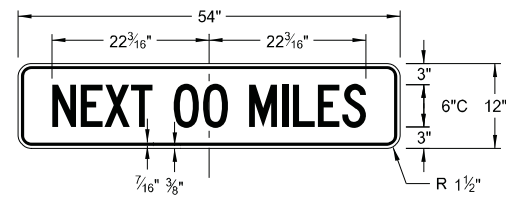

W20-52P-54
Legend: black (non-refl)
Background: orange

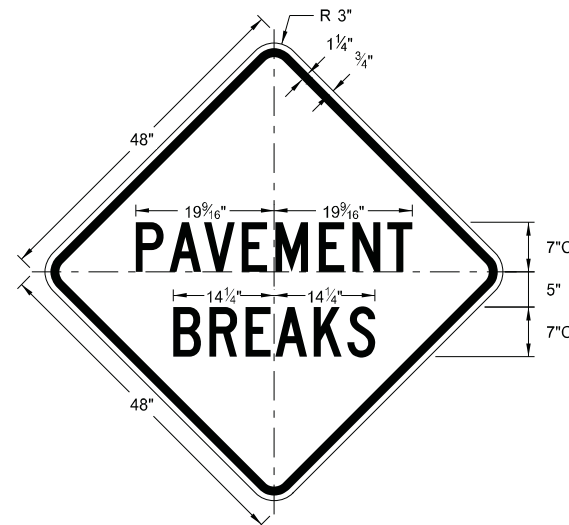

W21-52-48
Legend: black (non-refl)
Background: orange

NORTH DAKOTA DEPARTMENT OF TRANSPORTATION	
5-31-18	
REVISIONS	
DATE	CHANGE
11-01-19	Added details for sign W16-7aP-18.
8-01-24	Electronic Stamp/Signature.



08/01/24

BARRICADE AND CHANNELIZING DEVICE DETAILS

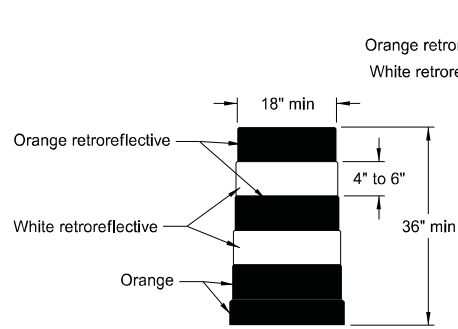

DELINEATOR DRUM

Provide horizontal, circumferential, alternating orange and white retroreflective stripes 4" to 6" wide for drum markings. Use a minimum of two orange and two white stripes with the top stripe being orange for each drum. Do not exceed 3" nonretroreflective spaces between the horizontal orange and white stripes. Avoid placement of stripes on drum ribs or indentations. Use closed top drums that will not allow collection of debris. Do not place ballast on the top of drum.

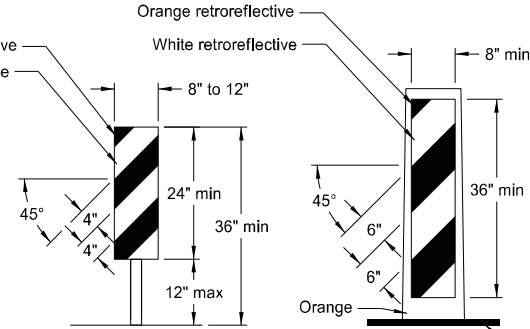

VERTICAL PANEL

Provide alternating orange and white retroreflective stripes, sloping downward in direction vehicular traffic is to pass. Place retroreflective sheeting on both sides of panel with a minimum of 270 square inches of retroreflective area facing vehicular traffic. Where the height of the retroreflective material on the vertical panel is 36 inches or more, use a stripe width of 6 inches.

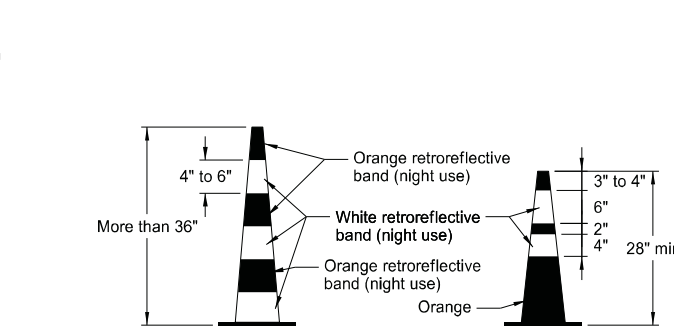

TRAFFIC CONE

Provide retroreflective cones more than 36" in height by alternating orange and white retroreflective stripes. Use a minimum of two orange and two white stripes for each cone with the top stripe being orange. Use maximum 3" nonretroreflective space between the orange and white stripes.

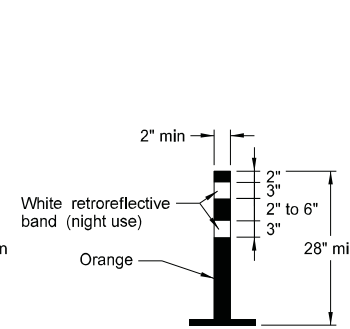

TUBULAR MARKER

Provide retroreflective tubular markers more than 42" in height by alternating four 4" to 6" wide orange and white stripes with the top stripe being orange.

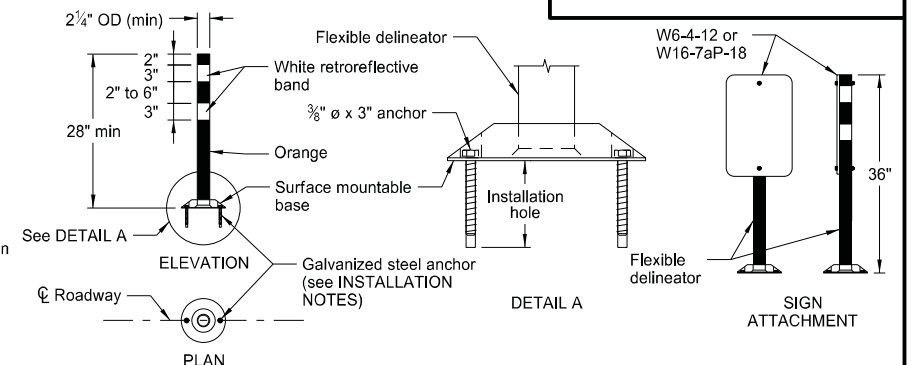

FLEXIBLE DELINEATOR

INSTALLATION NOTES:

1. Drill installation holes to diameter and depth required by manufacturer's specifications.
2. For removal, remove anchors and fill installation hole with an epoxy designed to bond to pavement surface.
3. In lieu of bolted down base, use an 8" x 8" butyl pad or hot melt butyl. Remove butyl as close as possible to pavement surface.

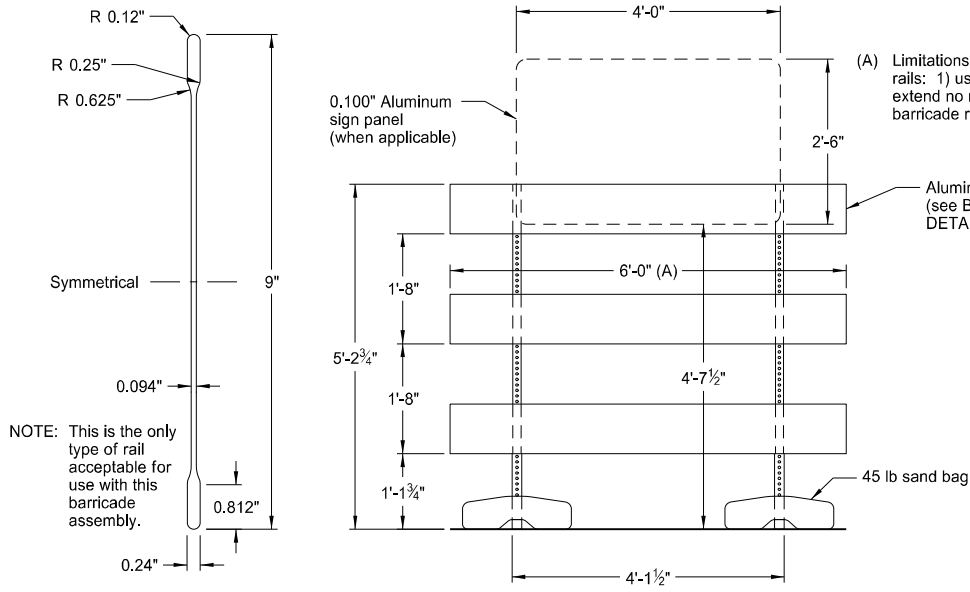

BARRICADE BLADE DETAIL

ELEVATION VIEW

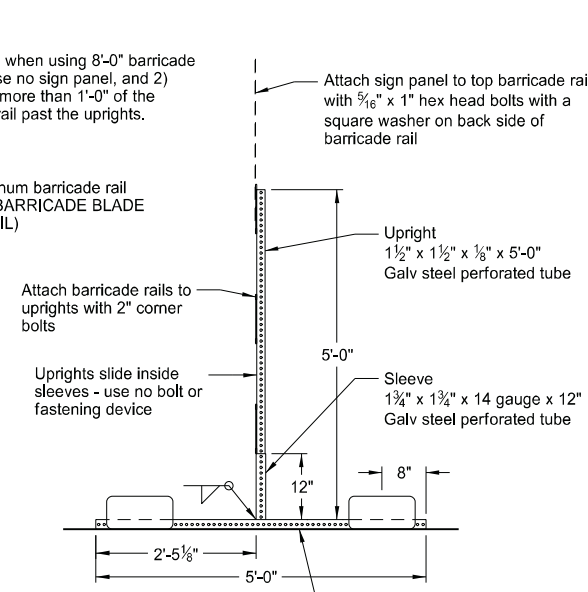

SIDE VIEW

BARRICADE ASSEMBLY DETAIL (Aluminum Barricade Rails)

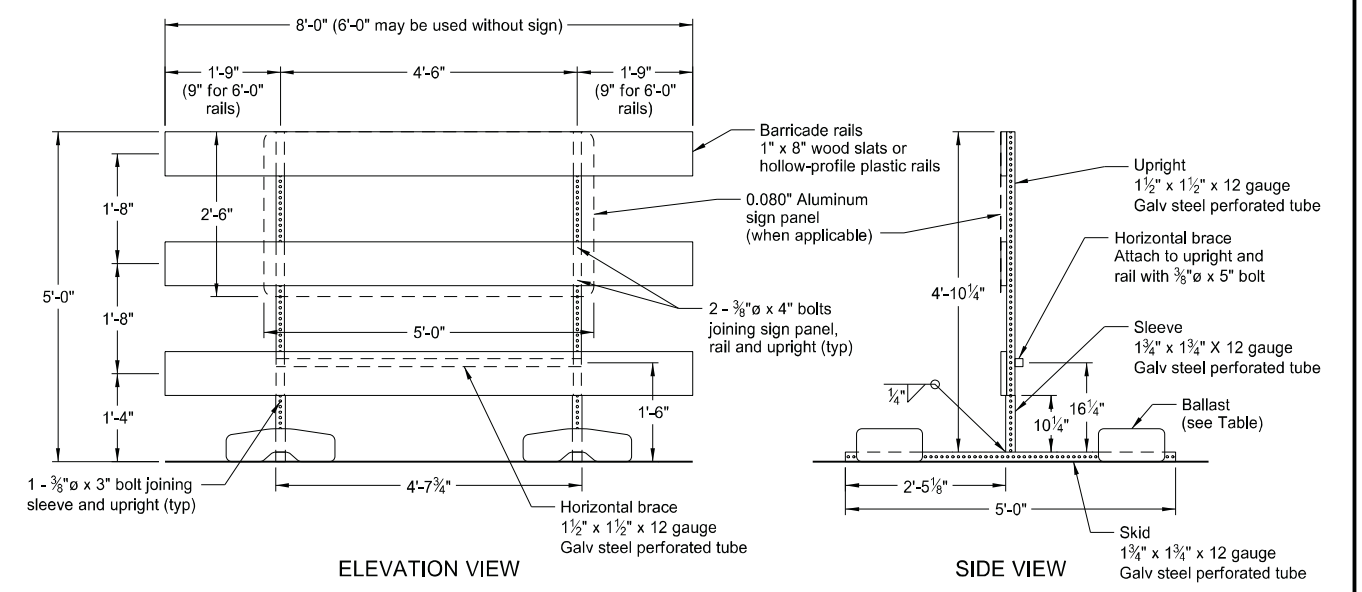

ELEVATION VIEW

SIDE VIEW

BARRICADE ASSEMBLY DETAIL (Wood or Plastic Rails)

NOTE: For barricade markings use alternating orange and white retroreflective stripes, sloping downward in the direction traffic is to pass. Place retroreflective sheeting on both sides of the rails with a minimum of 270 square inches of visible retroreflective area facing vehicular traffic. When the barricade length is less than 36", use a rail stripe width of 4".

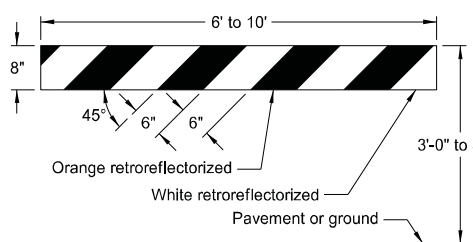

TYPE I BARRICADE

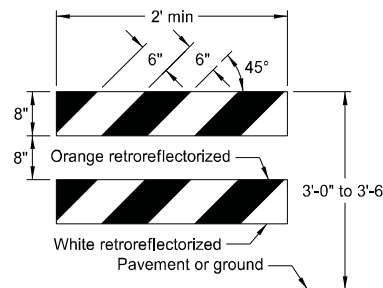

TYPE II BARRICADE

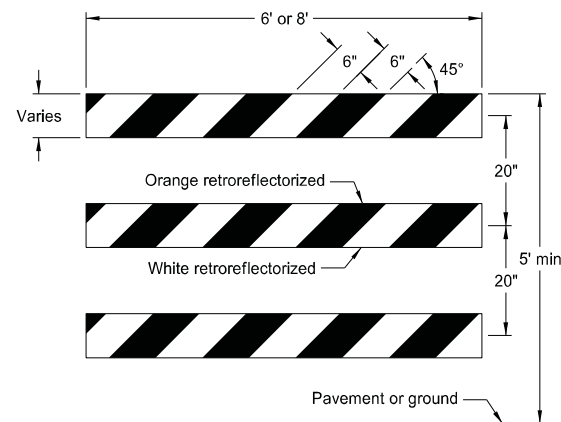

TYPE III BARRICADE

BARRICADE RAIL DETAILS

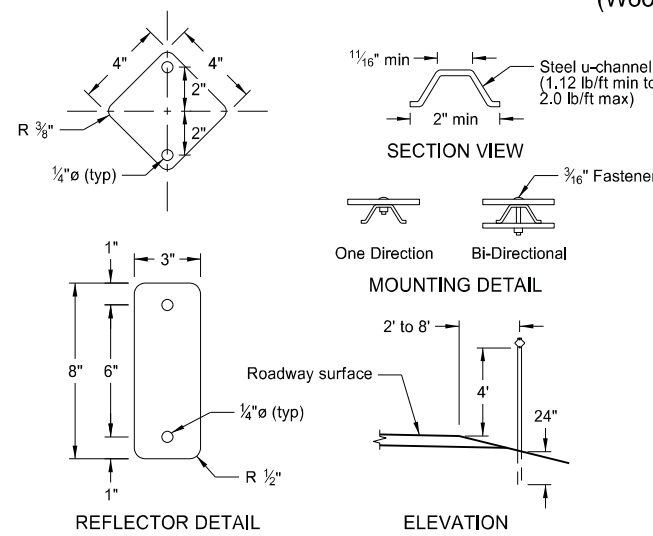

REFLECTOR DETAIL

ELEVATION

DELINEATORS

MINIMUM BALLAST (For each side of barricade support)

Without Sign	4 - 25 lb sandbags
With Sign	6 - 25 lb sandbags

Note: Number of sandbags based on a wind speed of 55 MPH. Sandbags assumed to be placed at or near the ends of the skids.

NORTH DAKOTA DEPARTMENT OF TRANSPORTATION	
10-3-13	
REVISIONS	
DATE	CHANGE
9-27-17	Updated to active voice
11-01-19	Revised details for Flexible Delineator
8-01-24	Electronic Stamp/Signature



08/01/24

CONSTRUCTION SIGN PUNCHING AND MOUNTING DETAILS

Note: In curb sections, place signs a minimum horizontal distance of 2' from face of the curb to near edge of the sign.

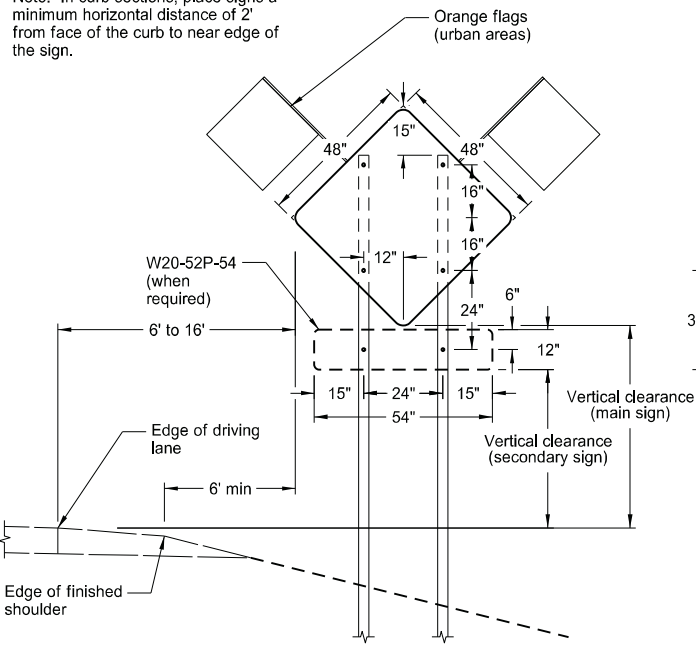

TYPICAL SECTION (48" x 48" diamond warning sign shown)

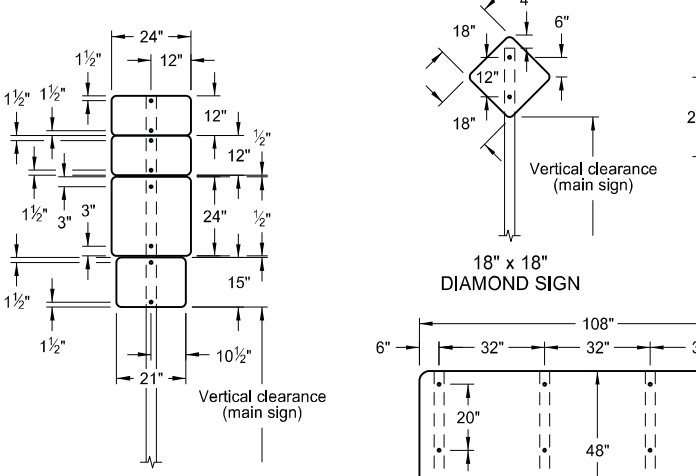

24" x 24" ROUTE MARKER ASSEMBLY

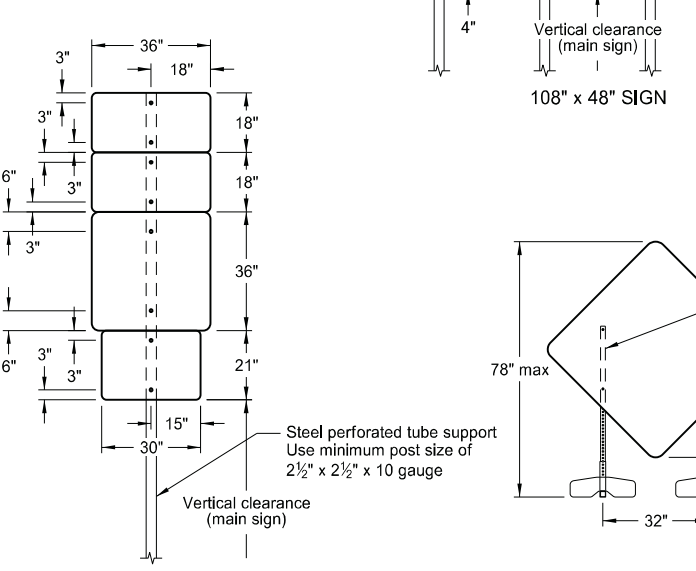

36" x 36" ROUTE MARKER ASSEMBLY

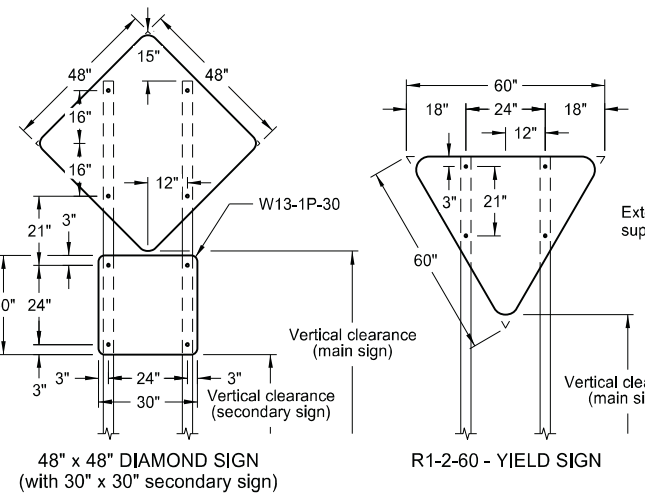

48" x 48" DIAMOND SIGN (with 30" x 30" secondary sign)

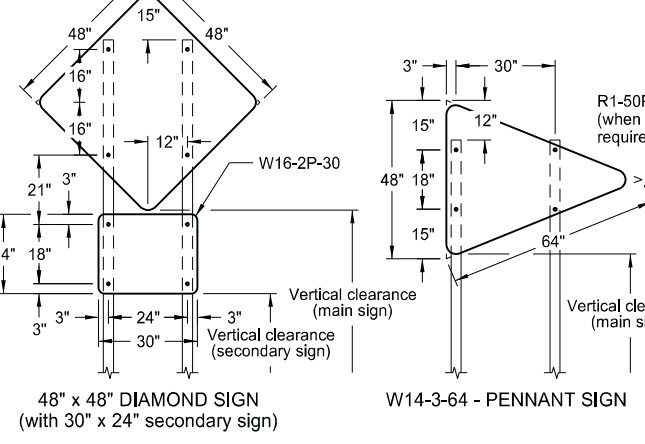

48" x 48" DIAMOND SIGN (with 30" x 24" secondary sign)

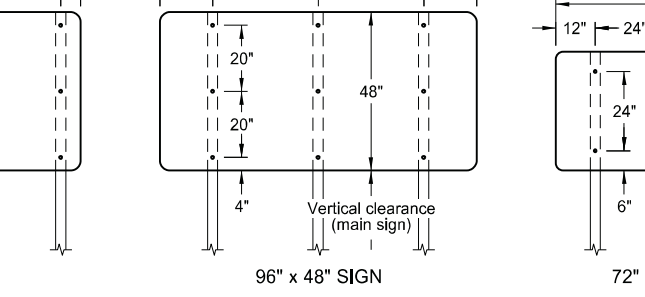

108" x 48" SIGN

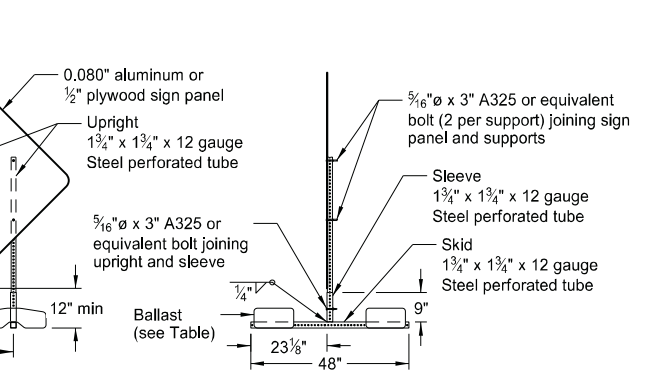

PORTABLE SIGN SUPPORT LOW-MOUNTING HEIGHT

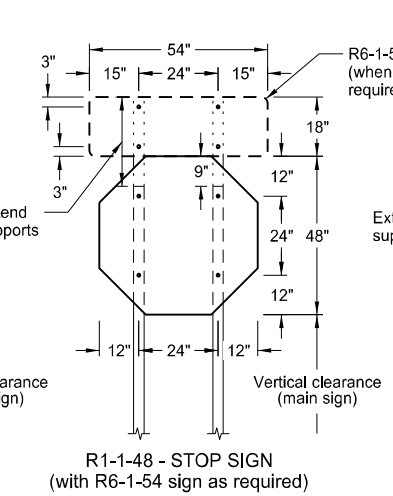

R1-2-60 - YIELD SIGN

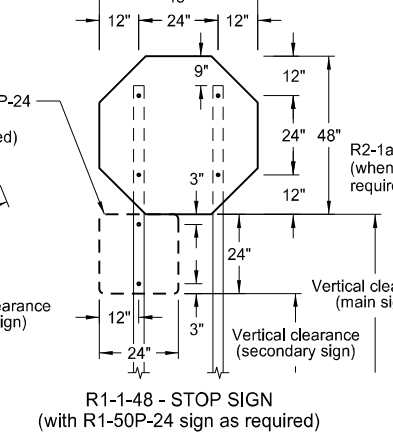

R1-50P-24 (when required)

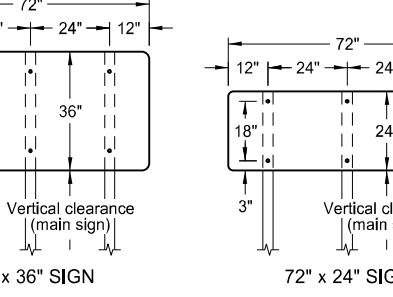

72" x 36" SIGN

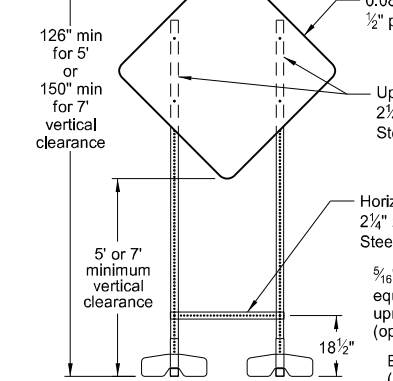

PORTABLE SIGN SUPPORT HIGH-MOUNTING HEIGHT

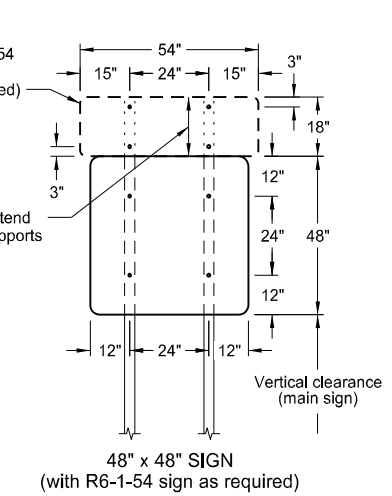

R1-1-48 - STOP SIGN (with R6-1-54 sign as required)

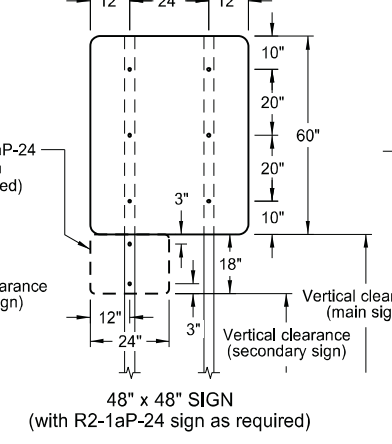

R2-1aP-24 (when required)

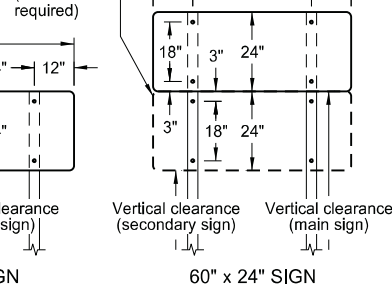

60" x 24" SIGN

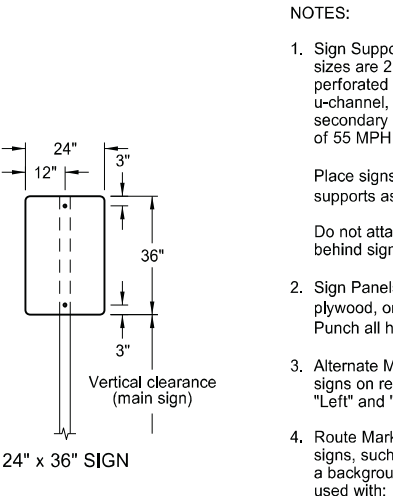

48" x 48" SIGN (with R6-1-54 sign as required)

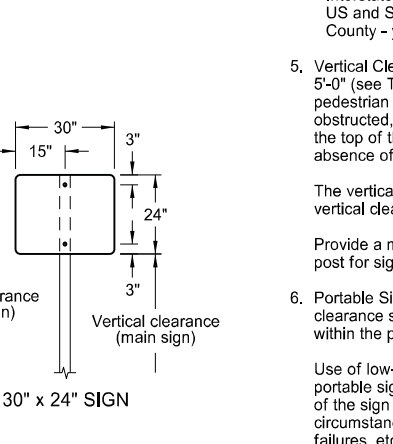

30" x 24" SIGN

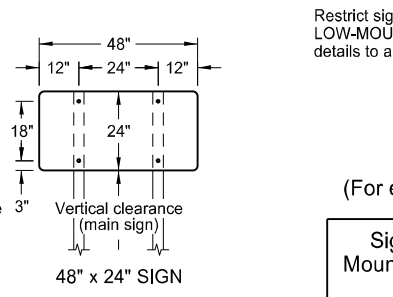

72" x 24" SIGN

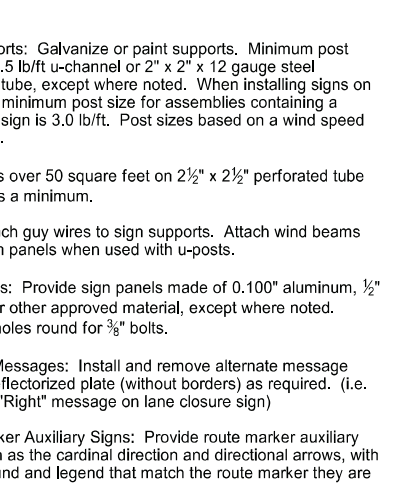

24" x 36" SIGN

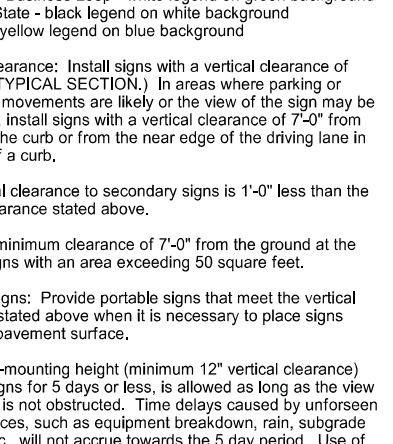

G20-1b-60 (when required)

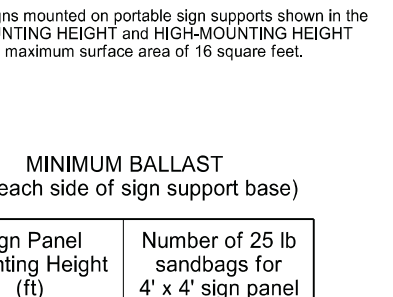

48" x 24" SIGN

- NOTES:
- Sign Supports: Galvanize or paint supports. Minimum post sizes are 2.5 lb/ft u-channel or 2" x 2" x 12 gauge steel perforated tube, except where noted. When installing signs on u-channel, minimum post size for assemblies containing a secondary sign is 3.0 lb/ft. Post sizes based on a wind speed of 55 MPH. Place signs over 50 square feet on 2 1/2" x 2 1/2" perforated tube supports as a minimum. Do not attach guy wires to sign supports. Attach wind beams behind sign panels when used with u-posts.
 - Sign Panels: Provide sign panels made of 0.100" aluminum, 1/2" plywood, or other approved material, except where noted. Punch all holes round for 3/8" bolts.
 - Alternate Messages: Install and remove alternate message signs on reflectorized plate (without borders) as required. (i.e. "Left" and "Right" message on lane closure sign)
 - Route Marker Auxiliary Signs: Provide route marker auxiliary signs, such as the cardinal direction and directional arrows, with a background and legend that match the route marker they are used with: Interstate - white legend on blue background Interstate Business Loop - white legend on green background US and State - black legend on white background County - yellow legend on blue background
 - Vertical Clearance: Install signs with a vertical clearance of 5'-0" (see TYPICAL SECTION.) In areas where parking or pedestrian movements are likely or the view of the sign may be obstructed, install signs with a vertical clearance of 7'-0" from the top of the curb or from the near edge of the driving lane in absence of a curb. The vertical clearance to secondary signs is 1'-0" less than the vertical clearance stated above. Provide a minimum clearance of 7'-0" from the ground at the post for signs with an area exceeding 50 square feet.
 - Portable Signs: Provide portable signs that meet the vertical clearance stated above when it is necessary to place signs within the pavement surface. Use of low-mounting height (minimum 12" vertical clearance) portable signs for 5 days or less, is allowed as long as the view of the sign is not obstructed. Time delays caused by unforeseen circumstances, such as equipment breakdown, rain, subgrade failures, etc., will not accrue towards the 5 day period. Use of R9-8 through R9-11a series, W1-6 through W1-8 series, M4-10, and E5-1 is allowed for longer than 5 days. Restrict signs mounted on portable sign supports shown in the LOW-MOUNTING HEIGHT and HIGH-MOUNTING HEIGHT details to a maximum surface area of 16 square feet.

MINIMUM BALLAST (For each side of sign support base)

Sign Panel Mounting Height (ft)	Number of 25 lb sandbags for 4' x 4' sign panel
1'	6
5'	8
7'	10

Note: The number of sandbags are based on a wind speed of 55 MPH. Place sandbags at or near the ends of sklds.

NORTH DAKOTA DEPARTMENT OF TRANSPORTATION	
10-4-13	
REVISIONS	
DATE	CHANGE
11-14-13	Revised Note 6
9-27-17	Updated to active voice
11-01-19	Revised 60"x24" sign detail
8-01-24	Electronic Stamp/Signature



08/01/24

ROAD CLOSURE LAYOUTS

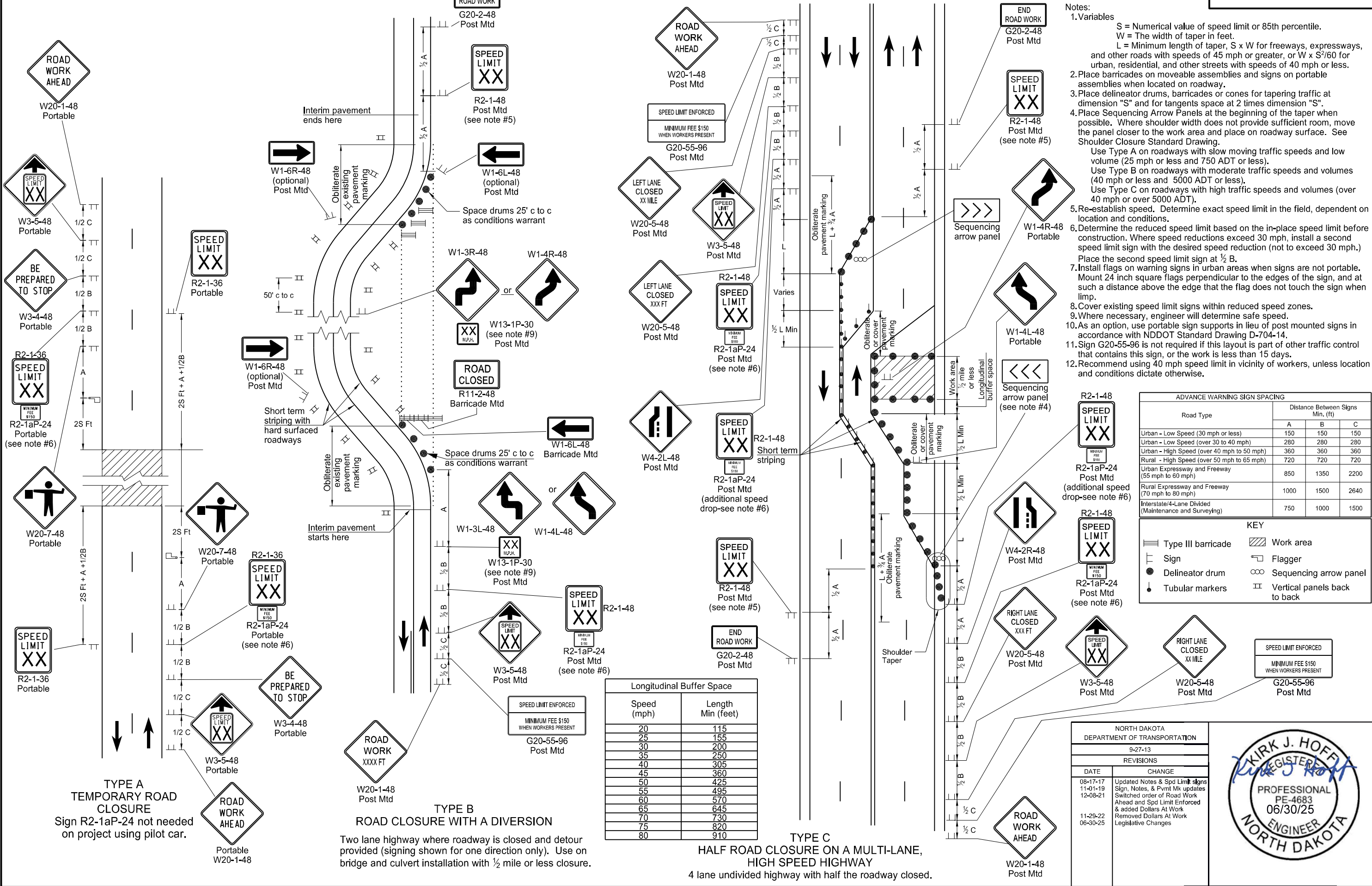

- Notes:
- Variables
 - S = Numerical value of speed limit or 85th percentile.
 - W = The width of taper in feet.
 - L = Minimum length of taper, S x W for freeways, expressways, and other roads with speeds of 45 mph or greater, or $W \times S^2/60$ for urban, residential, and other streets with speeds of 40 mph or less.
 - Place barricades on moveable assemblies and signs on portable assemblies when located on roadway.
 - Place delineator drums, barricades or cones for tapering traffic at dimension "S" and for tangents space at 2 times dimension "S".
 - Place Sequencing Arrow Panels at the beginning of the taper when possible. Where shoulder width does not provide sufficient room, move the panel closer to the work area and place on roadway surface. See Shoulder Closure Standard Drawing.
 - Use Type A on roadways with slow moving traffic speeds and low volume (25 mph or less and 750 ADT or less).
 - Use Type B on roadways with moderate traffic speeds and volumes (40 mph or less and 5000 ADT or less).
 - Use Type C on roadways with high traffic speeds and volumes (over 40 mph or over 5000 ADT).
 - Re-establish speed. Determine exact speed limit in the field, dependent on location and conditions.
 - Determine the reduced speed limit based on the in-place speed limit before construction. Where speed reductions exceed 30 mph, install a second speed limit sign with the desired speed reduction (not to exceed 30 mph). Place the second speed limit sign at 1/2 B.
 - Install flags on warning signs in urban areas when signs are not portable. Mount 24 inch square flags perpendicular to the edges of the sign, and at such a distance above the edge that the flag does not touch the sign when limp.
 - Cover existing speed limit signs within reduced speed zones.
 - Where necessary, engineer will determine safe speed.
 - As an option, use portable sign supports in lieu of post mounted signs in accordance with NDDOT Standard Drawing D-704-14.
 - Sign G20-55-96 is not required if this layout is part of other traffic control that contains this sign, or the work is less than 15 days.
 - Recommend using 40 mph speed limit in vicinity of workers, unless location and conditions dictate otherwise.

Road Type	Distance Between Signs Min. (ft)		
	A	B	C
Urban - Low Speed (30 mph or less)	150	150	150
Urban - Low Speed (over 30 to 40 mph)	280	280	280
Urban - High Speed (over 40 mph to 50 mph)	360	360	360
Rural - High Speed (over 50 mph to 65 mph)	720	720	720
Urban Expressway and Freeway (55 mph to 60 mph)	850	1350	2200
Rural Expressway and Freeway (70 mph to 80 mph)	1000	1500	2640
Interstate/4-Lane Divided (Maintenance and Surveying)	750	1000	1500

KEY

	Type III barricade		Work area
	Sign		Flagger
	Delineator drum		Sequencing arrow panel
	Tubular markers		Vertical panels back to back

Speed (mph)	Length Min (feet)
20	115
25	155
30	200
35	250
40	305
45	360
50	425
55	495
60	570
65	645
70	730
75	820
80	910

NORTH DAKOTA DEPARTMENT OF TRANSPORTATION	
9-27-13	
REVISIONS	
DATE	CHANGE
08-17-17	Updated Notes & Spd Limit signs
11-01-19	Sign, Notes, & Pmnt Mx updates
12-08-21	Switched order of Road Work Ahead and Spd Limit Enforced & added Dollars At Work
11-29-22	Removed Dollars At Work
06-30-25	Legislative Changes



TERMINAL AND SEAL COAT SIGN LAYOUTS

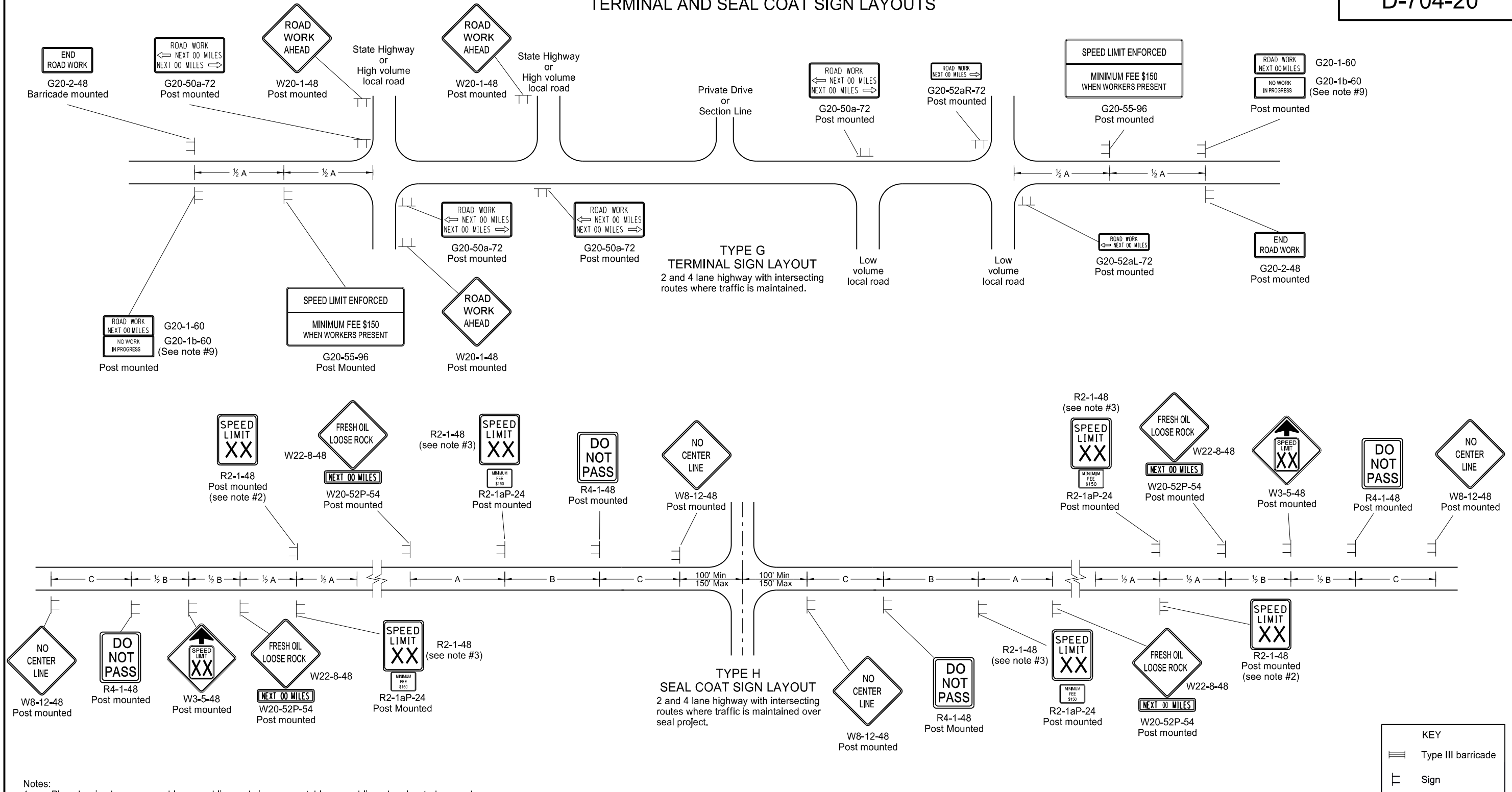

- Notes:
- Place barricades on moveable assemblies and signs on portable assemblies when located on roadway.
 - Determine the exact speed limit in the field, based on location and conditions.
 - Determine the reduced speed limit based on the in place speed limit before construction. Where speed limit reductions exceed 30 MPH, install a second speed limit sign with the desired speed reduction (not to exceed 30 MPH.) Place the second speed limit sign at 1/2 B.
 - Install flags on warning signs in urban areas when signs are not portable. Mount 24 inch square flags perpendicular to the edges of the sign, and at such a distance above the edge that the flag does not touch the sign when limp.
 - Cover existing speed limit signs within a reduced speed zone.
 - On seal coat projects, place signs R2-1-48, R2-1aP-24, R4-1-48, W22-8-48 and W20-52P-54 after all important intersections and at five mile intervals. Place sign W8-12-48 after all important intersections and at 2 mile intervals until short term center line pavement marking is placed.
 - As an option, use portable sign supports in lieu of post mounted signs in accordance with the NDDOT Standard Drawing D-704-14.
 - Cover or remove speed limit signs from layout Type H when loose aggregate is removed.
 - Install sign G20-1b-60 when work is suspended for winter.
 - Use other traffic control layouts in immediate work areas. Place sign R2-1aP-24 below speed limit signs in reduced speed limit work areas.
 - Sign G20-55-96 is not required if this layout is part of other traffic control that contains this sign, or the work is less than 15 days.
 - Recommend using 40 mph speed limit in vicinity of workers, unless location and conditions dictate otherwise.

ADVANCE WARNING SIGN SPACING			
Road Type	Distance Between Signs Min. (ft)		
	A	B	C
Urban - Low Speed (30 mph or less)	150	150	150
Urban - Low Speed (over 30 to 40 mph)	280	280	280
Urban - High Speed (over 40 mph to 50 mph)	360	360	360
Rural - High Speed (over 50 mph to 65 mph)	720	720	720
Urban Expressway and Freeway (55 mph to 60 mph)	850	1350	2200
Rural Expressway and Freeway (70 mph to 80 mph)	1000	1500	2640
Interstate/4-Lane Divided (Maintenance and Surveying)	750	1000	1500

NORTH DAKOTA DEPARTMENT OF TRANSPORTATION	
9-27-13	
REVISIONS	
DATE	CHANGE
08-17-17	Updated notes & sign numbers
11-01-19	Updated note & sign
12-08-21	Switched order of Road Work and Spd Limit Enforced & added Dollars At Work
11-29-22	Removed Dollars At Work
06-30-25	Legislative Changes

KEY

≡ Type III barricade

⊥ Sign



CONSTRUCTION TRUCK AND TEMPORARY DETOUR LAYOUTS

KEY

- Type III barricade
- Sign
- Work area
- Flagger

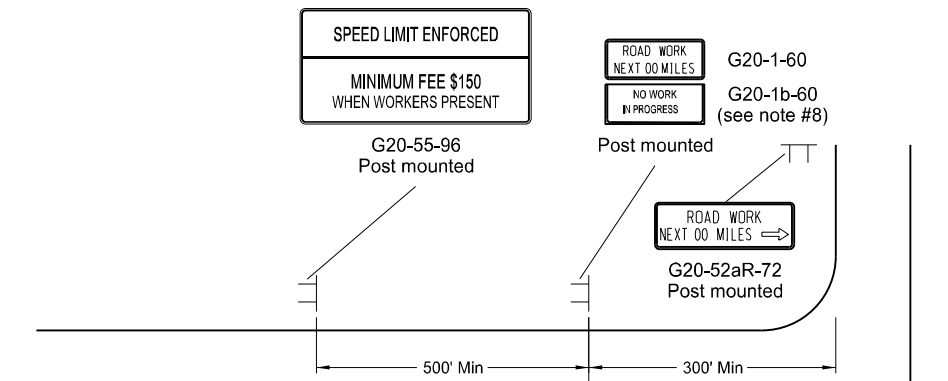
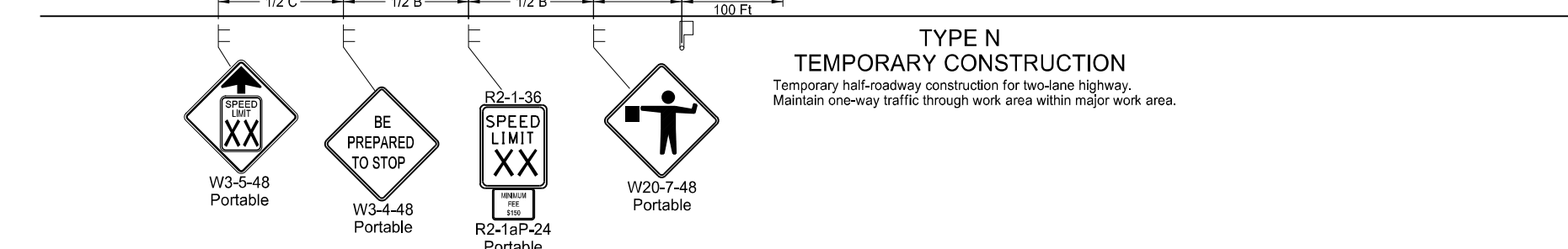
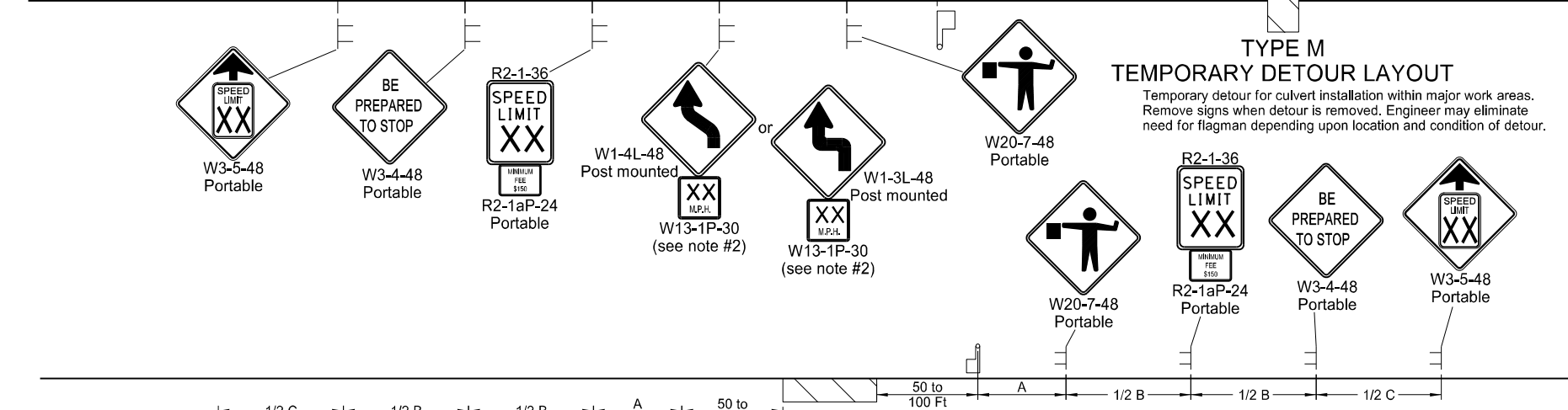
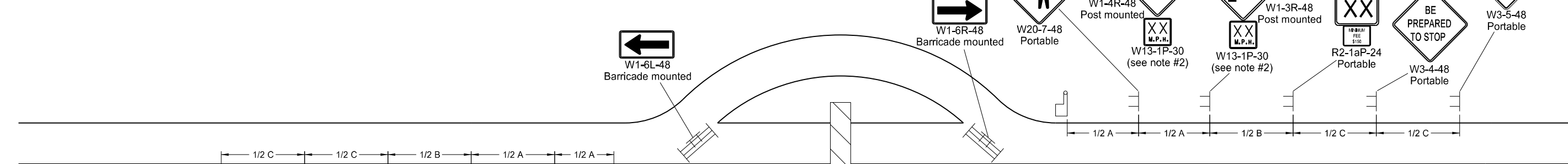
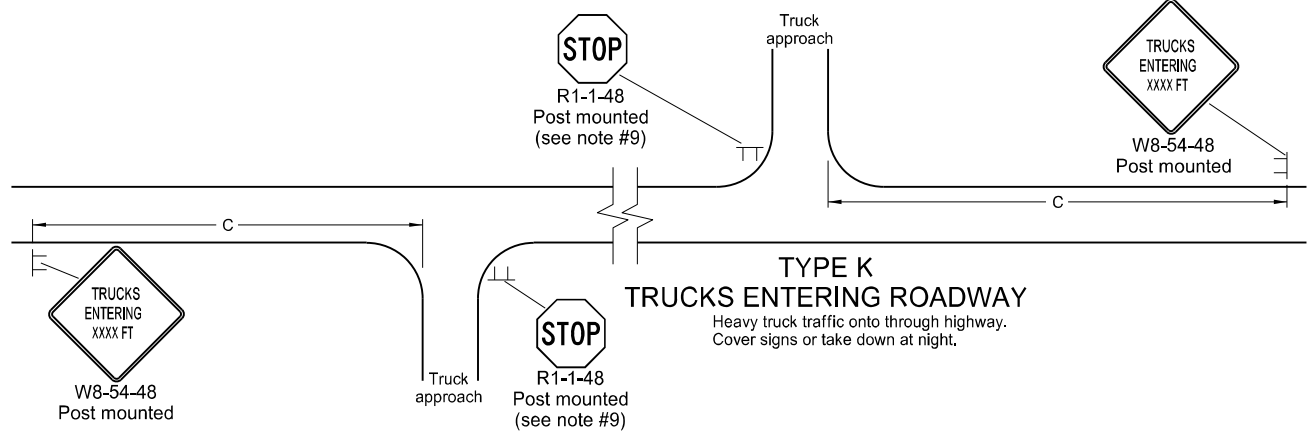

- Notes:
- Place barricades on a moveable assemblies and signs on portable assemblies when located on roadway.
 - Where necessary, safe speed to be determined by the Engineer.
 - Determine the reduced speed limit based on the in-place speed limit before construction. Where speed reductions exceed 30 mph, install a second speed limit sign with the desired speed reduction (not to exceed 30 mph.) Place the second speed limit sign at 1/2 B.
 - Install flags on warning signs in urban areas when signs are not portable. Mount 24 inch square flags perpendicular to the edges of the sign, and at such a distance above the edge that the flag does not touch the sign when limp.
 - Cover existing speed limit signs within a reduced speed zone.
 - Covered (when approved by engineer) or obliterated pavement marking measured as Obliteration of Pavement Marking.
 - As an option, use portable sign supports in lieu of post mounted signs in accordance with NDDOT Standard Drawing D-704-14.
 - Install sign G20-1b-60 when work is suspended for winter.
 - If existing stop sign is in place, a 48" stop sign is not required.
 - Sign G20-55-96 is not required if layout is part of other traffic control that contains this sign, or if work is less than 15 days.
 - Recommend using 40 mph speed limit in vicinity of workers, unless location and conditions dictate otherwise.

Road Type	Distance Between Signs Min. (ft)		
	A	B	C
Urban - Low Speed (30 mph or less)	150	150	150
Urban - Low Speed (over 30 to 40mph)	280	280	280
Urban - High Speed (over 40 mph to 50 mph)	360	360	360
Rural - High Speed (over 50 mph to 65 mph)	720	720	720
Urban Expressway and Freeway (55 mph to 60 mph)	850	1350	2200
Rural Expressway and Freeway (70 mph to 80 mph)	1000	1500	2640
Interstate/4-Lane Divided (Maintenance and Surveying)	750	1000	1500

NORTH DAKOTA DEPARTMENT OF TRANSPORTATION	
9-27-13	
REVISIONS	
DATE	CHANGE
08-17-17	Update notes & sign numbers
11-01-19	Revised sign numbers & note 7
12-09-21	Added Speed Limit Enforced and Dollars At Work signs
11-29-22	Removed Dollars At Work
06-30-25	Legislative Changes



MISCELLANEOUS SIGN LAYOUTS

D-704-26

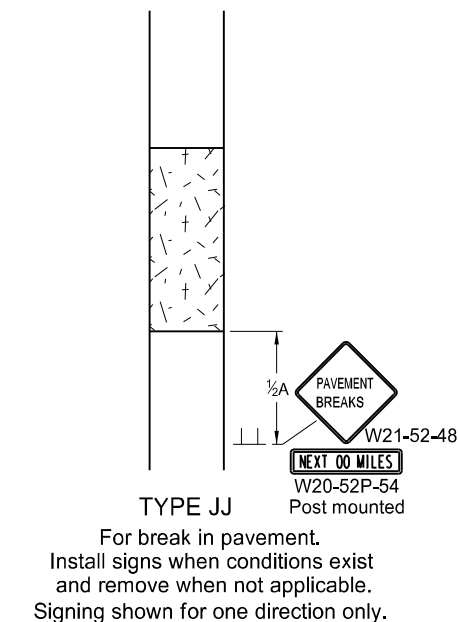
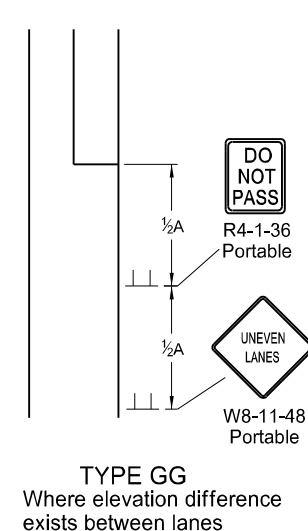
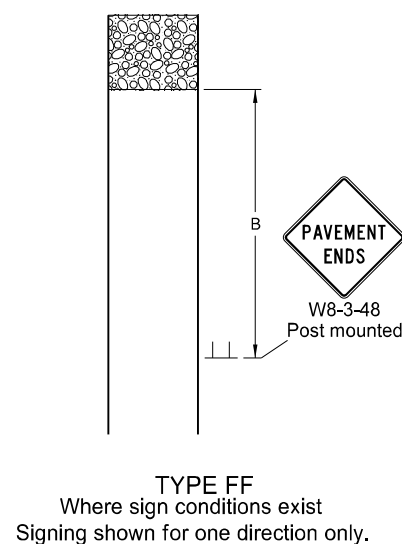
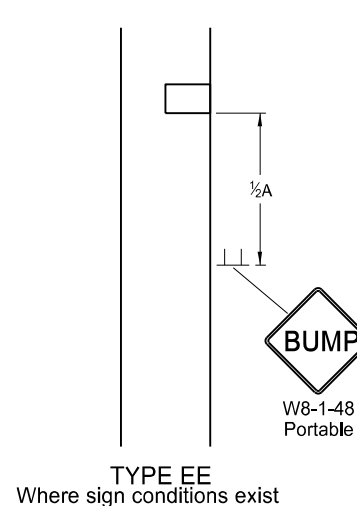
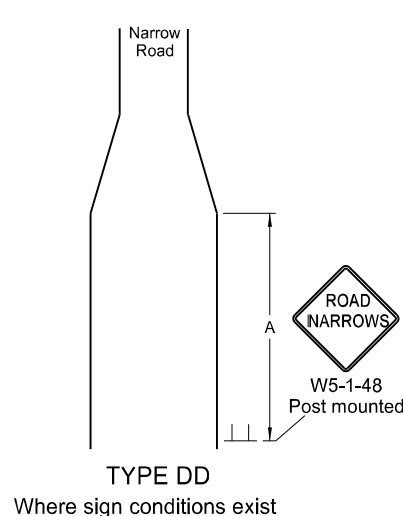
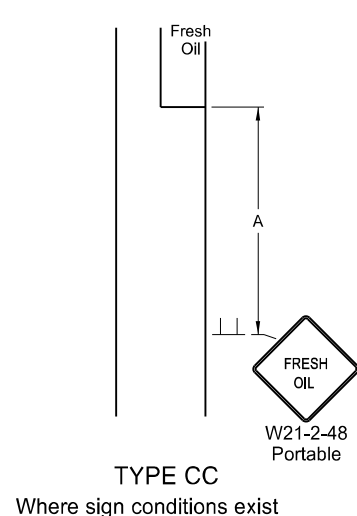
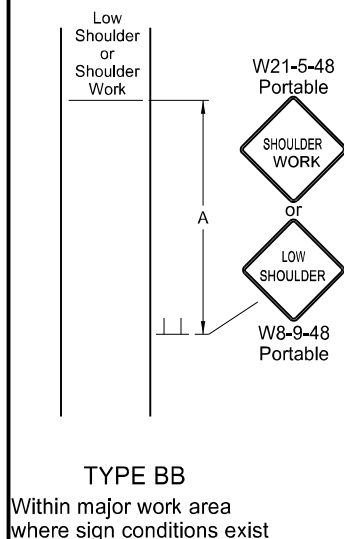
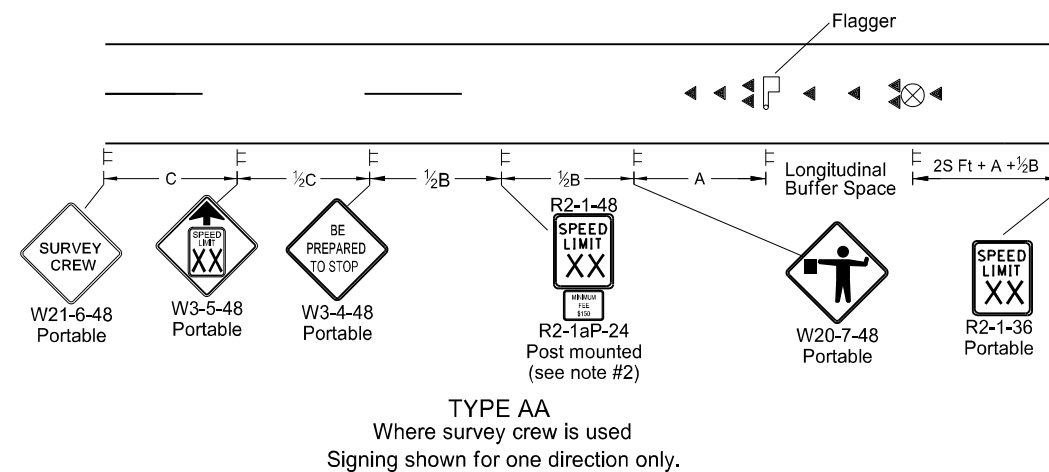
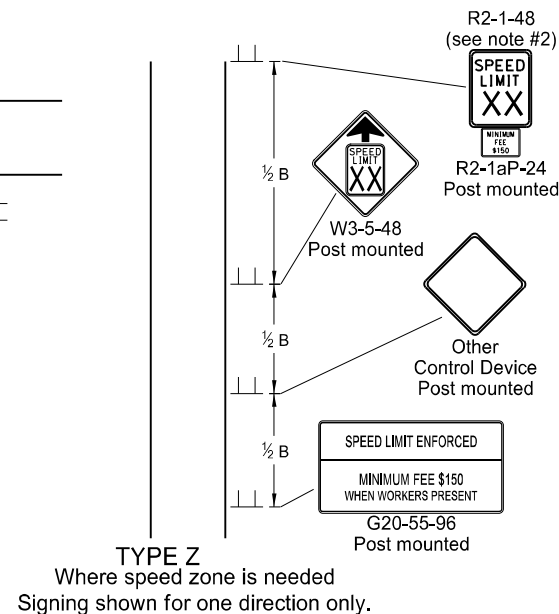
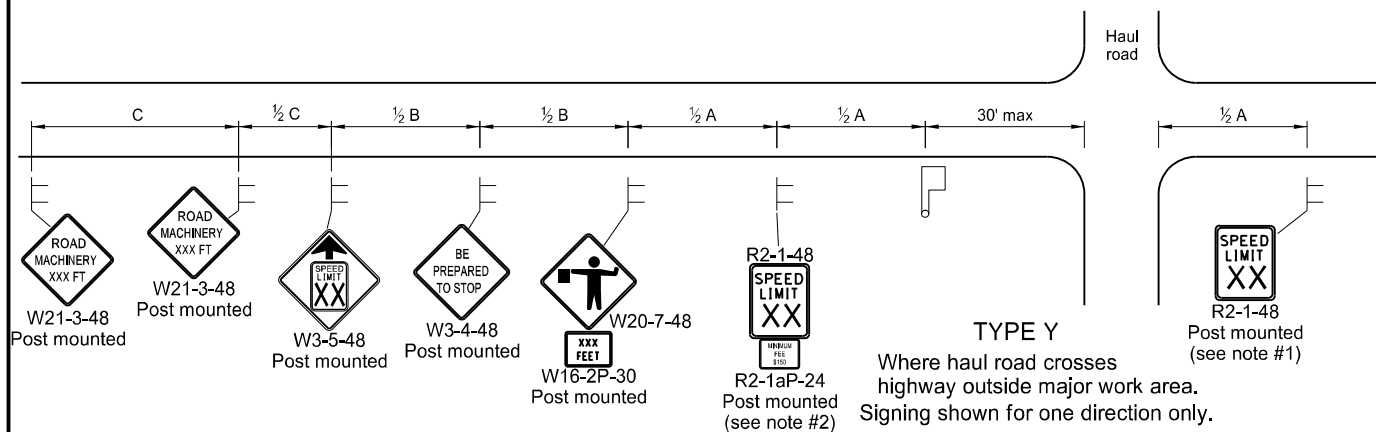

KEY

- Flagger
- Sign
- Cones
- Survey Equipment

S = Numerical value of speed limit or 85th percentile.

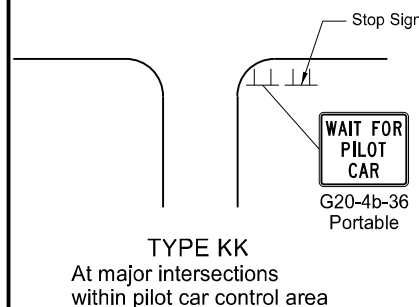

- Notes**
- Re-establish speed limit. Determine exact speed limit in the field, dependent on location and conditions. Determine reduced speed limit based on in-place speed limit before construction. Where speed reductions exceed 30 mph, install a second speed limit sign with the desired speed reduction (not to exceed 30 mph.)
 - Place the second speed limit sign at 1/2 B.
 - Install flags on warning signs in urban areas when signs are not portable. Mount 24 inch square flags perpendicular to the edges of the sign, and at such a distance above the edge that the flag does not touch the sign when limp.
 - Cover existing speed limit signs within reduced speed zones.
 - As an option, use portable sign supports in lieu of post mounted signs in accordance with NDDOT Standard Drawing D-704-14.
 - Sign G20-55-96 is not required if this standard is part of other traffic control layouts, or work is less than 15 days.
 - When pilot car operation is used, place sign G20-4b-36 "Wait For Pilot Car" at major intersections within pilot car control area.
 - Recommend 40 mph speed limit in vicinity of workers, unless location and conditions dictate otherwise.
 - Layouts shown for one direction only.

ADVANCE WARNING SIGN SPACING			
Road Type	Distance Between Signs Min. (ft)		
	A	B	C
Urban - Low Speed (30 mph or less)	150	150	150
Urban - Low Speed (over 30 to 40 mph)	280	280	280
Urban - High Speed (over 40 mph to 50 mph)	360	360	360
Rural - High Speed (over 50 mph to 65 mph)	720	720	720
Urban Expressway and Freeway (65 mph to 60 mph)	850	1350	2200
Rural Expressway and Freeway (70 mph to 80 mph)	1000	1500	2640
Interstate/4-Lane Divided (Maintenance and Surveying)	750	1000	1500

Longitudinal Buffer Space	
*Speed (mph)	Length Min (feet)
20	115
25	155
30	200
35	250
40	305
45	360
50	425
55	495
60	570
65	645
70	730
75	820
80	910

* Posted speed, off-peak 85th percentile speed prior to work starting, or the anticipated operating speed in mph.

NORTH DAKOTA DEPARTMENT OF TRANSPORTATION	
9-27-13	
REVISIONS	
DATE	CHANGE
08-17-17	Added speed limit signs. Updated notes & sign numbers
11-01-19	Revised note 5 & sign numbers
02-23-23	Revised distance & removed signs
06-30-25	Legislative Changes



MOBILE OPERATION (PAVEMENT MARKING)

D-704-27

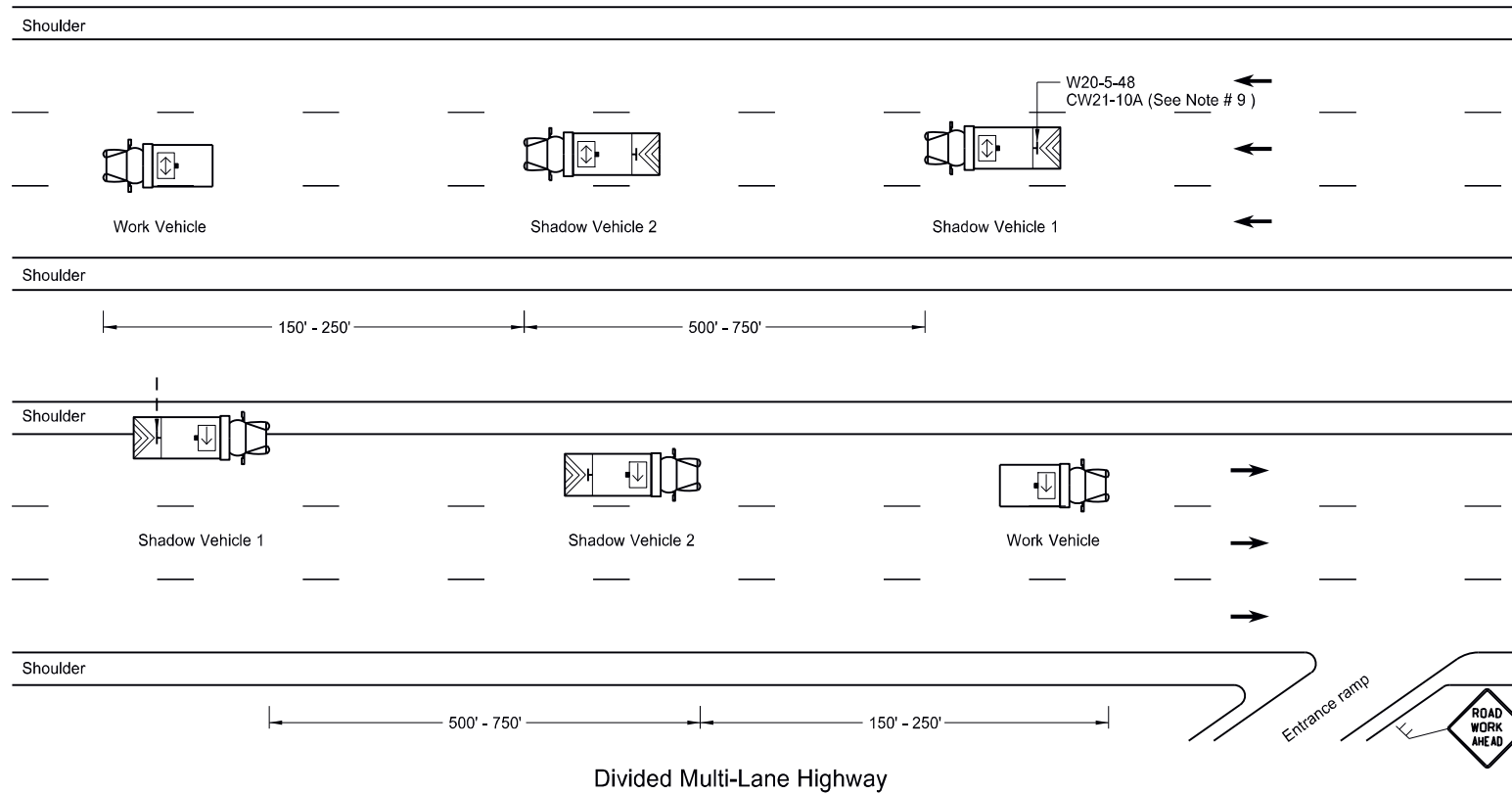
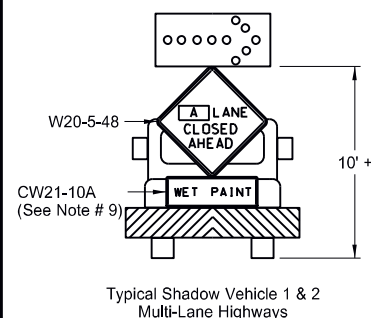
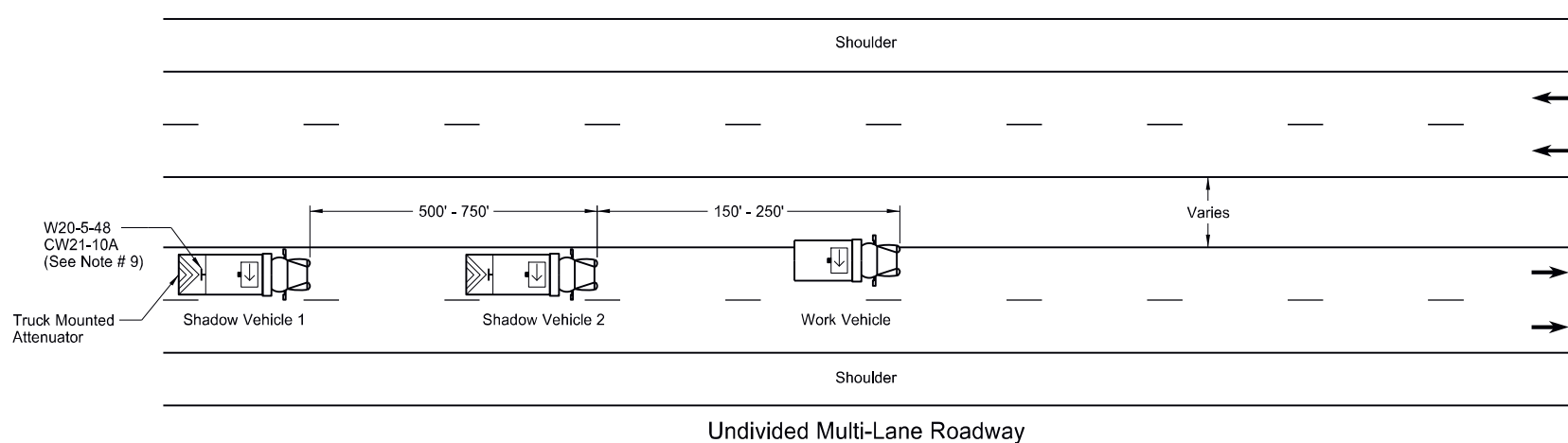
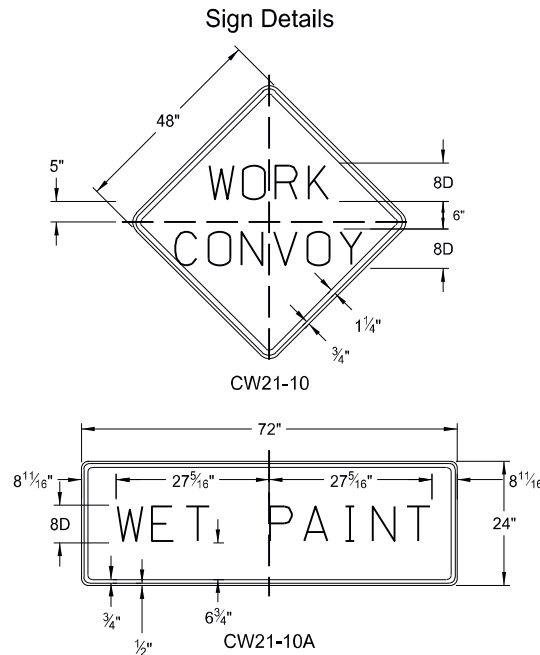
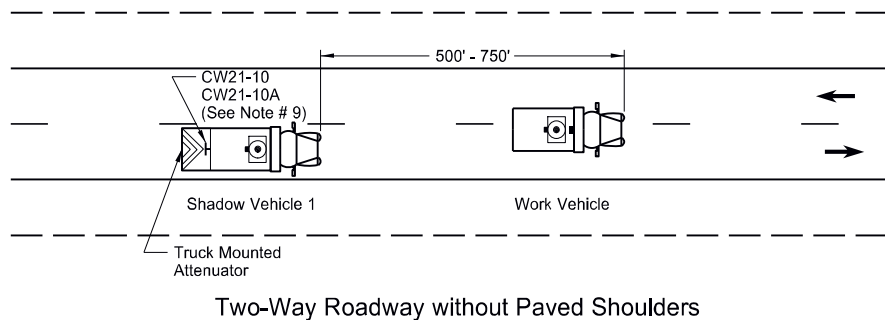
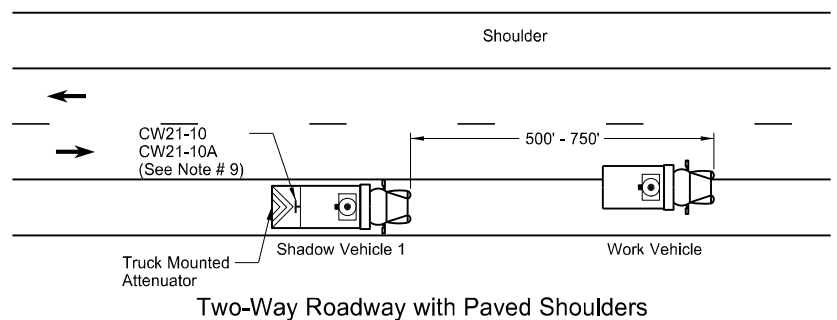
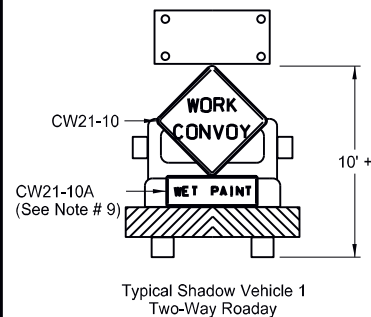

- Notes
- Use additional vehicles you choose to be in the convoy with truck mounted attenuators, at your own expense.
 - Display yellow rotating beacons or strobe lights on shadow and work vehicles, unless otherwise stated in the plans.
 - Use Type B or Type C flashing arrow panels controlled from inside the vehicle.
 - Provide each vehicle with two-way electronic communication capability.
 - Move shadow vehicle 1 first to shadow other convoy vehicles when convoy changes lane.
 - Vary vehicle spacing between shadow vehicle 1 and shadow vehicle 2 based on sight distance restrictions. Motorists approaching the work convoy need to see trail vehicle in time to slow down and/or change lanes as they approach shadow vehicle.
 - Sign Colors
Letters = Black
Border = Black
Background = Orange
 - As an option, use shadow vehicle 2 the paint tender vehicle.
 - Use sign CW21-10A only during painting operation.
 - Pull over work and shadow vehicles periodically to allow motor vehicle traffic to pass on two lane - two way roadways.

KEY

- Sign
- Truck mounted attenuator
- Flashing arrow panels:
 - Right directional
 - Left directional
 - Double arrow directional
 - Caution Mode

NORTH DAKOTA DEPARTMENT OF TRANSPORTATION	
9-27-13	
REVISIONS	
DATE	CHANGE
6-18-14	Removed shadow vehicle 2 on two lane roadways
9-27-17	Updated to active voice
11-08-19	Changed Standard Heading
8-02-24	Electronic Stamp/Signature.

KIRK J. HOFF
REGISTERED
PROFESSIONAL
PE-4683
ENGINEER
NORTH DAKOTA

08/02/24

PORTABLE SIGN SUPPORT ASSEMBLY

D-704-50

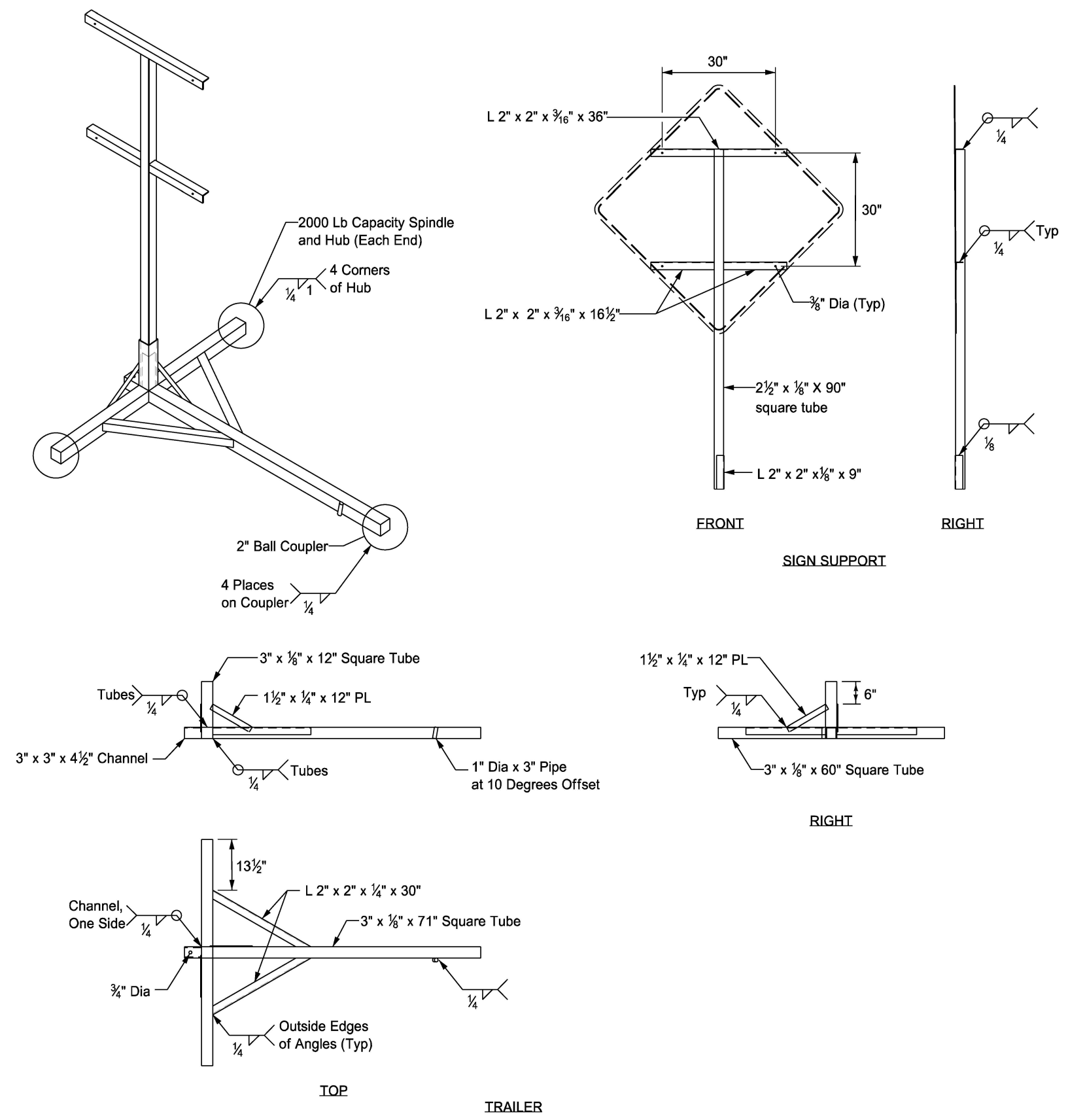

Notes:

- ① Maximum 250 pound weight of assembly.
- ② Use a 14" wheel and tire.
- ③ Use no automotive and equipment axle assemblies for trailer-mounted sign supports.
- ④ Other NCHRP 350 or MASH crash tested assemblies are acceptable.

NORTH DAKOTA DEPARTMENT OF TRANSPORTATION	
11-23-10	
REVISIONS	
DATE	CHANGE
12/02/2020	Updated Note to active voice.

KIRK J. HOFF
REGISTERED
PROFESSIONAL
PE-4683
ENGINEER
NORTH DAKOTA
12 02 2020

BITUMINOUS LABORATORY

D-706-1

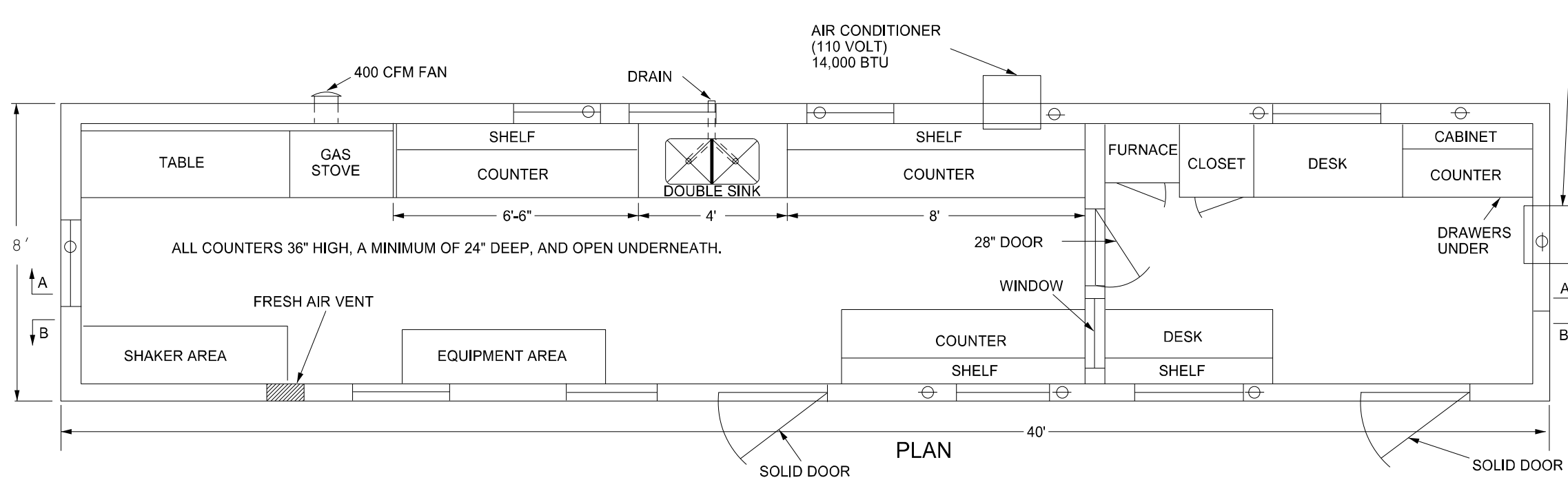

- Provide a laboratory with the following:
1. A 1'x1' shelf at 36" above the regular countertop.
 2. Double compartment stainless steel sink, with each compartment a minimum of 16"x14"x10" deep. Provide water service lines made of copper or plastic and a diameter of 1/2 inch.
 3. An exhaust fan capable of removing inside air at a rate of 400 CFM.
 4. Fresh air vent hinged to open or close manually.
 5. 24" x 48" table capable of holding a 200 lb masonry saw with a minimum clearance of 36" above the table.
 6. A water supply tank with a capacity of 500 gallons and a 20 gallon capacity pressure tank on the pump.
 7. Heavy duty type locks, latches, and hinges for doors made to withstand the intense use in service.
 8. A wall between the office and the work area properly insulated to prevent the transmission of heat and noise.
 9. The steel cable tie downs and ground anchors at each corner of the lab.
 10. Electrical service entrance wired for 100 amps and separate circuits for air conditioners. Space convenience outlets in counter areas a minimum of four feet apart.

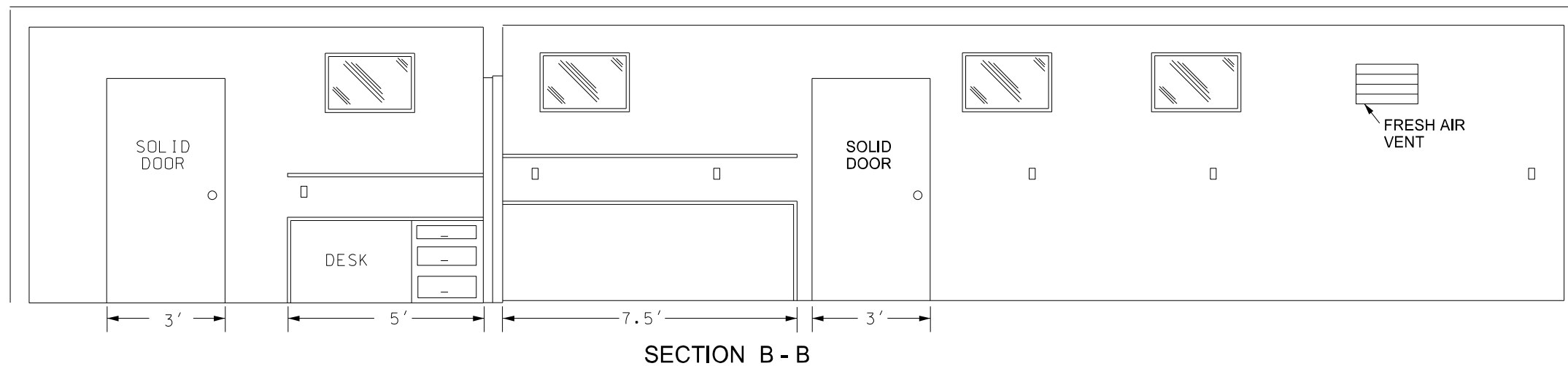
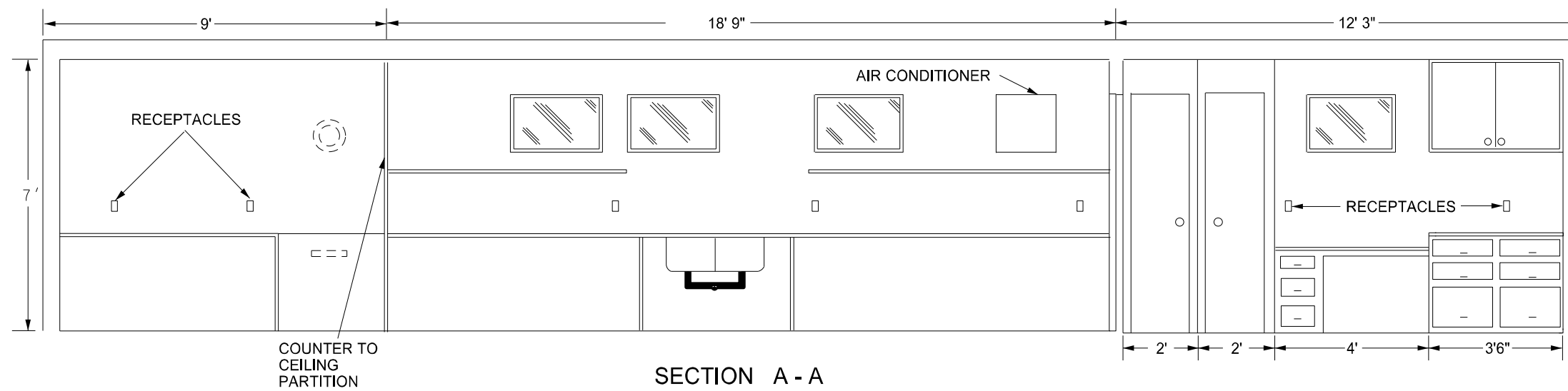

NORTH DAKOTA DEPARTMENT OF TRANSPORTATION	
10-03-13	
REVISIONS	
DATE	CHANGE
07-30-14	Changed standard's title and revised notes.
01-11-16	Revised notes.
08-27-19	New Design Engineer PE Stamp

This document was originally issued and sealed by Kirk J Hoff, Registration Number PE-4683, on 08/27/19 and the original document is stored at the North Dakota Department of Transportation

PAVEMENT MARKING

D-762-4

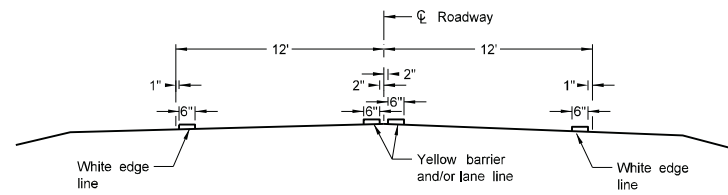

Two Lane Two Way
RURAL ROADWAY

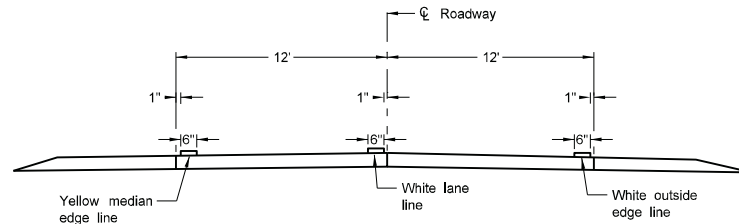

Two Lane Roadway
INTERSTATE HIGHWAY
Concrete Section

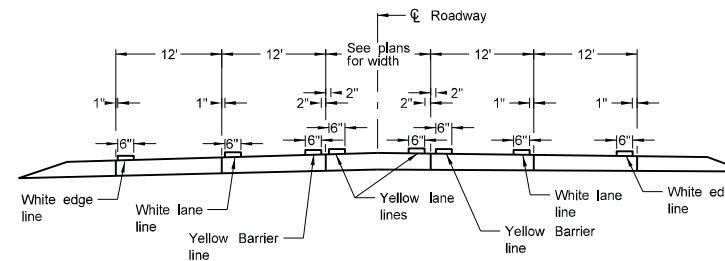

RURAL FIVE LANE ROADWAY
Concrete Section

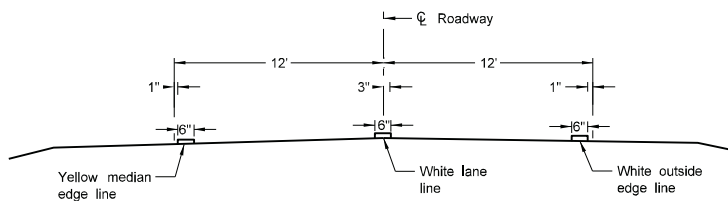

Two Lane Divided
Rural Roadway
PRIMARY HIGHWAY
Asphalt Section

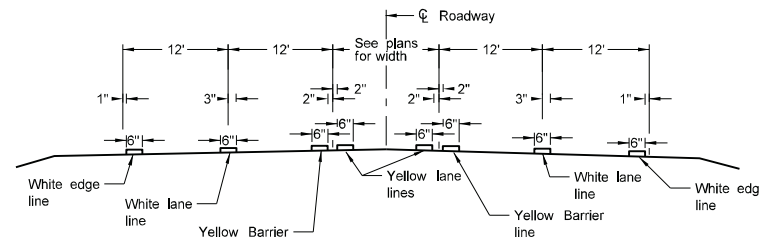

RURAL FIVE LANE ROADWAY
Asphalt Section

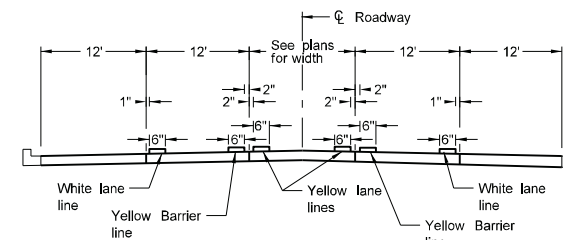

URBAN FIVE LANE SECTION
Concrete Section

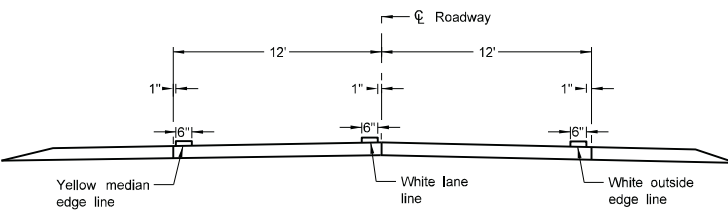

Two Lane Divided
Rural Roadway
PRIMARY HIGHWAY
Concrete Section

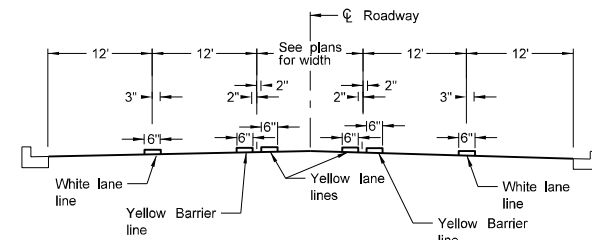

URBAN FIVE LANE SECTION
Asphalt Section

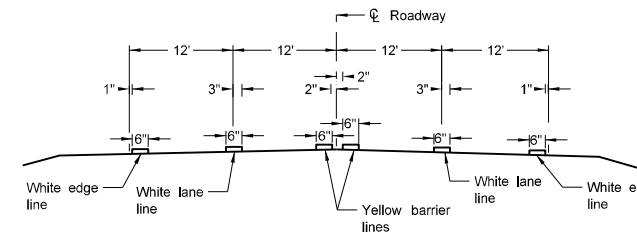

RURAL FOUR LANE ROADWAY
Asphalt Section

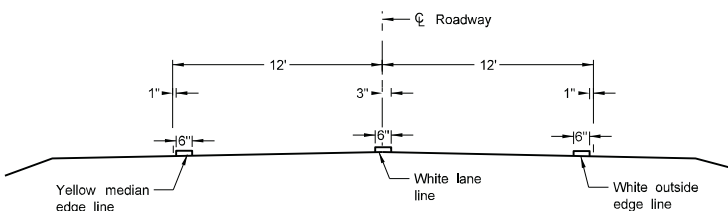

Two Lane Roadway
INTERSTATE HIGHWAY
Asphalt Section

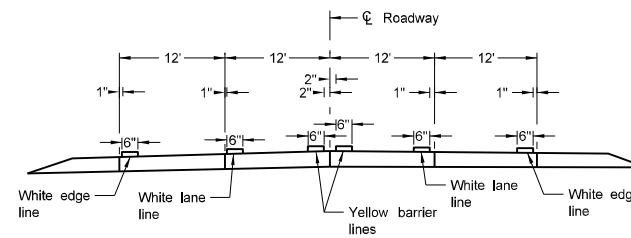

RURAL FOUR LANE ROADWAY
Concrete Section

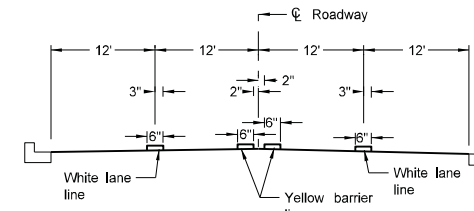

URBAN FOUR LANE SECTION
Asphalt Section

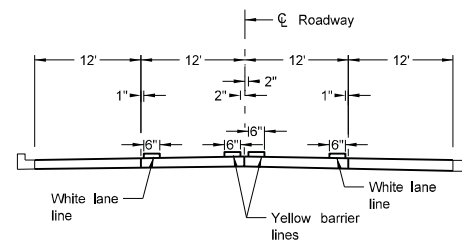

URBAN FOUR LANE SECTION
Concrete Section

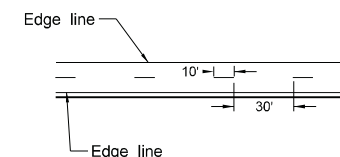

CENTERLINE PAVEMENT MARKING SKIP SPACING DETAIL

NOTES:

1. Continue edge lines through private drives and field drives. Break edge lines for intersections.

For section lines, county roads, and street approaches, stripe the radii and edge lines of the paved surface within the right of way except where curb and gutter is present.
2. Normal width line - 6 inches wide for freeways, expressways, and ramps; 6 inches for all other roadways with speed limits > 40 mph.
3. Use 4 or 6 inch wide pavement marking for all other roadways with speed limits < 40 mph.

NORTH DAKOTA DEPARTMENT OF TRANSPORTATION	
12-1-10	
REVISIONS	
DATE	CHANGE
10-17-17	Updated to active voice.
08-27-19	New Design Engineer PE Stamp.
11-22-23	Revised pavement marking widths.
07-09-24	Modified Note 1.

