

NDDOT ABBREVIATIONS

? This is a special text character used in the labeling of existing features. It indicates a feature that has an unknown characteristic, potentially based on: lack of description, location accuracy or purpose.

Abn abandoned
 Abut abutment
 Adj adjusted
 Aggr aggregate
 Ahd ahead
 ARV air release valve
 Align alignment
 Al alley
 Alt alternate
 Alum aluminum
 ADA Americans with Disabilities Act
 & and
 Appr approach
 Approx approximate
 ACP asbestos cement pipe
 Asph asphalt
 AC asphalt cement
 Assmd assumed
 @ at
 Atten attenuation
 ATR automatic traffic recorder
 Ave Avenue
 Avg average
 ADT average daily traffic

Bk back
 BF back face
 Balc balcony
 B Wire barbed wire
 Barr barricade
 Btry battery
 BI beehive inlet
 Beg begin
 BG below grade
 BM bench mark
 Bkwy bikeway
 Bit bituminous
 Blk block
 BH bore hole
 Bot bottom
 Blvd Boulevard
 Bndry boundary
 Brkwy breakaway
 Br bridge
 Bldg building
 Bus. business
 BV butterfly valve
 Byp bypass

C Gdrl cable guardrail
 Calc calculate
 CIP cast iron pipe
 CB catch basin
 CRS cationic rapid setting
 C Gd cattle guard
 C To C center to center
 CL or ☉ centerline
 Ch chain
 Chnlk chain-link
 Ch Blk channel block
 Ch Ch channel change
 Chk check
 Chsld chiseled
 Cir circle
 Cl class
 Clnt clean-out
 Clr clear
 Cl&gr clearing & grubbing
 Comb. combination
 Coml commercial
 Compr compression
 CADD computer aided drafting & design
 Conc concrete
 CECB concrete erosion control blanket
 Cond conductor
 Const construction
 Cont continuous
 CSB continuous split barrel sample
 Contr contraction
 Contr contractor
 CP control point
 Coord coordinate
 Cor corner
 Corr corrected
 CAES corrugated aluminum end section
 CAP corrugated aluminum pipe
 CMES corrugated metal end section
 CMP corrugated metal pipe
 CPVCP corrugated poly-vinyl chloride pipe
 CSES corrugated steel end section
 CSFES corrugated steel flared end section
 CSP corrugated steel pipe
 CSTES corrugated steel traversable end section
 Co County
 Crse course
 Ct Court
 Xarm cross arm
 Xbuck cross buck
 Xsec cross sections
 Xing crossing
 Xrd crossroad
 Crn crown

Culv culvert
 C&G curb & gutter
 CI curb inlet
 CR curb ramp
 C cut
 Dd Ld dead load
 Defl deflection
 Defm deformed
 DInt delineate
 DIntr delineator
 Depr depression
 Desc description
 Det detail
 DWP detectable warning panel
 Dtr detour
 Dia or ø diameter
 Dir direction
 Dist distance
 DM disturbed material
 DB ditch block
 DG ditch grade
 Dbl double
 Dn down
 Dwg drawing
 Dr drive
 Drwy driveway
 DI drop inlet
 D dry density
 Ea each
 Esmt easement
 E East
 EB Eastbound
 Elast elastomeric
 EL electric locker
 E Mtr electric meter
 EVSE electric vehicle supply equipment
 Elec electric/al
 EDM electronic distance meter
 Elev or El elevation
 Ellipt elliptical
 Emb embankment
 Emuls emulsion/emulsified
 ES end section
 Engr engineer
 ESS environmental sensor station
 Eq equal
 Evgr evergreen
 Exc excavation
 Exst existing
 Exp expansion
 Expy Expressway
 E external of curve
 Extru extruded

FOS factor of safety
 Fed Federal
 FP feed point
 Fn fence
 Fn P fence post
 FO fiber optic
 FD field drive
 F fill
 FAA fine aggregate angularity
 FH fire hydrant
 Fl flange
 Flrd flared
 FES flared end section
 F Bcn flashing beacon
 FA flight auger sample
 FL flow line
 Ftg footing
 FM force main
 Fnd found
 Fdn foundation
 Frac fractional
 Frwy freeway
 Frt front
 FF front face
 F Disp fuel dispenser
 FFP fuel filler pipes
 FLS fuel leak sensor
 Furn furnish/ed

NORTH DAKOTA DEPARTMENT OF TRANSPORTATION	
07-01-14	
REVISIONS	
DATE	CHANGE
04-23-18	General Revisions
09-20-18	General Revisions
12-18-20	General Revisions
08-16-22	General Revisions
04-14-25	General Revisions



NDDOT ABBREVIATIONS

D-101-2

Galv	galvanized	Ln	lane	Obsc	obscure(d)	Qty	quantity
Gar	garage	Lg	large	Ocpd	occupied	Qtr	quarter
Gs L	gas line	Lat	latitude	Ocpy	occupy		
G Reg	gas line regulator	Lt	left	O/s	offset		
GMV	gas main valve	Lens	lenses	OC	on center	Rad or R	radius
G Mtr	gas meter	Lvl	level	C	one dimensional consolidation	RR	railroad
GSV	gas service valve	Lvng	leveling	OC	organic content	Rlwy	railway
GVP	gas vent pipe	Lht	light	Orig	original	Rsd	raised
GV	gate valve	LP	light pole	O To O	out to out	RC	rapid curing
Ga	gauge	Ltg	lighting	OD	outside diameter	Rec	record
Gov	government	Liq	liquid	OH	overhead	Recy	recycle
Grd	graded/grade	LL	liquid limit			RAP	recycled asphalt pavement
Grnd	ground	Loc	location			RPCC	recycled portland cement concrete
GWM	ground water monitor	Long.	longitude	PMT	pad mounted transformer	Ref	reference
Gdrl	guardrail	Lp	loop	Pg	pages	R Mkr	reference marker
Gtr	gutter	LD	loop detector	Pntd	painted	RM	reference monument
		Lum	luminaire	Pr	pair	RP	reference point
				Pnl	panel	Refl	reflectorized
H Plg	H piling			Pk	park	RCB	reinforced concrete box
Hdwl	headwall	Mb	mailbox	PSD	passing sight distance	RCES	reinforced concrete end section
Ht	height	ML	main line	Pvmt	pavement	RCFES	reinforced concrete flared end section
Hel	helical	MH	manhole	Ped	pedestal	RCP	reinforced concrete pipe
HDPE	high density polyethylene	Mkd	marked	Ped	pedestrian	RCPS	reinforced concrete pipe sewer
HM	high mast	Mkr	marker	PPP	pedestrian pushbutton post	RCTES	reinforced concrete traversable end section
HP	high pressure	Mkg	marking	Pen.	penetration	Reinf	reinforcement
HPS	high pressure sodium	MA	mast arm	Perf	perforated	Res	reservation
HTCG	high tension cable guardrail	Matl	material	Per.	perimeter	Res	residence
Hwy	highway	Max	maximum	Perm	permanent	Ret	retaining
Hor	horizontal			PL	pipeline	Rev	reverse
HBP	hot bituminous pavement	Meas	measure	PI	place	Rt	right
HMA	hot mix asphalt	Mdn	median	P&P	plan & profile	R/W	right of way
Hyd	hydrant	MD	median drain	PL	plastic limit	Riv	river
Ph	hydrogen ion content	MC	medium curing	Pl or \bar{P}	plate	Rd	road
		MGS	Midwest Guardrail System	Pt	point	Rdbd	road bed
		MM	mile marker	PE	polyethylene	Rdwy	roadway
Id	identification	MP	mile post	PVC	polyvinyl chloride	RWIS	roadway weather information system
Incl	inclinometer tube	Min	minimum	PCC	Portland Cement concrete	Rk	rock
IMH	inlet manhole	Misc	miscellaneous	PP	power pole	Rt	route
ID	inside diameter	Mon	monument	Preempt	preemption		
Inst	instrument	Mnd	mound	Prefab	prefabricated		
Intchg	interchange	Mtbl	mountable	Prfmd or Pref	performed		
Intmdt	intermediate	Mtd	mounted	Prep	preparation		
Intscn	intersection	Mtg	mounting	Press.	pressure		
Inv	invert	Mk	muck	PRV	pressure relief valve		
IP	iron pipe			Prestr	prestressed		
				Pvt	private		
				PD	private drive		
Jt	joint	Neop	neoprene	Prod.	production/produce		
Jct	junction	Ntwk	network	Prog	programmed		
		N	North	Prop.	property		
		NE	Northeast	Ppsd	proposed		
		NW	Northwest	PB	pull box		
		NB	Northbound				
		No. or #	number				

NORTH DAKOTA DEPARTMENT OF TRANSPORTATION	
07-01-14	
REVISIONS	
DATE	CHANGE
08-03-15	General Revisions
04-23-18	General Revisions
12-18-20	General Revisions
08-16-22	General Revisions
04-14-25	General Revisions

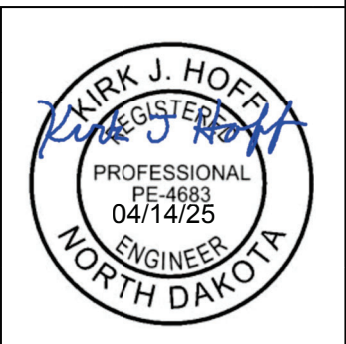

NDDOT ABBREVIATIONS

D-101-3

Salv	salvage(d)	Tel	telephone
San	sanitary sewer line	Tel B	Telephone Booth
Sec	section	Tel P	telephone pole
SL	section line	Tv	television
Sep	separation	Temp	temperature
Seq	sequence	Temp	temporary
Serv	service	TBM	temporary bench mark
Sht	sheet	T	thinwall tube sample
Shtng	sheeting	Ts	topsoil
Shldr	shoulder	Traf	traffic
Sw or Sdwk	sidewalk	TSCB	traffic signal control box
SD	sight distance	Tr	trail
SN	sign number	Transf	transformer
Sig	signal	Trans	transition
Sgl	single	TT	transmission tower
SRCP	slotted reinforced concrete pipe	TES	traversable end section
SC	slow curing	Trans	transverse
SS	slow setting	Trtd	treated
Sm	small	Trmt	treatment
S	South	Qc	triaxial compression
SE	Southeast	TERO	tribal employment rights ordinance
SW	Southwest	Tpl	triple
SB	Southbound	Typ	typical
Sp	spaces		
Spcl	special	Qu	unconfined compressive strength
SA	special assembly	Ugrnd	underground
SP	special provisions	Util	utility
G	specific gravity		
Spk	spike	VG	valley gutter
SB	split barrel sample	Vap	vapor
SH	sprinkler head	Vert	vertical
SV	sprinkler valve	VCP	vitrified clay pipe
Sq	square	Vol	volume
Stk	stake	VSFS	vehicle speed feedback sign
Std	standard		
N	standard penetration test	Wkwy	walkway
Std Specs	standard specifications	W	water content
Stm L	steam line	WGV	water gate valve
SEC	steel encased concrete	WL	water line
SMA	stone matrix asphalt	WM	water main
SSD	stopping sight distance	WMV	water main valve
SD	storm drain	W Mtr	water meter
St	street	WSV	water service valve
SPP	structural plate pipe	WW	water well
SPPA	structural plate pipe arch	Wrng	wearing
Str	structure	WIM	weigh in motion
Subd	subdivision	W	west
Sub	subgrade	WB	westbound
Sub Prep	subgrade preparation	Wrng	wiring
Ss	subsoil	W/	with
SS	supplement specification	W/o	without
Supp	supplemental		
Surf	surfacing		
Surv	survey		
Sym	symmetrical		

NORTH DAKOTA DEPARTMENT OF TRANSPORTATION	
07-01-14	
REVISIONS	
DATE	CHANGE
08-03-15	General Revisions
04-23-18	General Revisions
12-18-20	General Revisions
08-16-22	General Revisions
04-14-25	General Revisions



NDDOT ABBREVIATIONS

MEASUREMENTS

ac acres
 A ampere
 Bd Ft board feet
 Cd candela
 cm centimeter
 C coulomb
 CF cubic feet
 m3 cubic meter
 m3/s cubic meters per second
 CY cubic yard
 CY/mi cubic yards per mile
 D or Deg degree
 F Fahrenheit
 F farad
 ft feet/foot
 Gal gallon
 G giga
 Ha hectare
 H henry
 Hz hertz
 hr hour(s)
 in. inch
 J joule
 K kelvin
 kN kilo newton
 kPa kilo pascal
 kg kilogram
 kg/m3 kilogram per cubic meter
 km kilometer
 K Kip(s)
 LF linear foot
 L litre
 Lm lumen
 L sum lump sum
 Lx lux
 M Hr man hour
 M mega
 m meter
 m/s meters per second
 mi mile
 mL milliliter
 mm millimeter
 mm/hr millimeters per hour
 n nano
 N newton
 Pa pascal
 lb pounds
 sec seconds
 S siemens
 SF square feet
 km2 square kilometer
 m2 square meter
 SY square yard
 Sta Yd station yards
 SI Systems International

T tesla
 T/mi tons per mile
 V volt
 W watt
 Wb weber

SURVEY DESCRIPTIONS

Az azimuth
 Bs backsight
 Brg bearing
 BP Cap blue plastic cap
 BS both sides
 BC brass cap
 CC closing corner
 CS curve to spiral
 Eq equation
 E external of curve
 FS far side
 FB field book
 Fs foresight
 Geod geodetic
 GIS Geographical Information System
 GPS Global Positioning System
 HI height of instrument
 IM iron monument
 I Pn iron pin
 LS Land Surveyor (licensed)
 LSIT Land Surveyor In Training
 L length of curve
 LC long chord
 LB level book
 MC meander corner
 Mer meridian
 M mid ordinate of curve
 NGS National Geodetic Survey
 NS near side
 Obsn observation
 Off Loc office location
 OP Cap orange plastic cap
 PK Parker-Kalon nail
 P Cap plastic cap
 PP Cap pink plastic cap
 PCC point of compound curve
 PC point of curve
 PI point of intersection
 PRC point of reverse curvature
 PT point of tangent
 POC point on curve
 POT point on tangent
 RTP random traverse point
 Rge range
 RP Cap red plastic cap
 SC spiral to curve
 SC standard corner
 ST spiral to tangent
 Sta station
 SE superelevation
 Tan tangent
 T tangent (semi)
 TS tangent to spiral
 Twp township
 TB transit book
 TP traverse point
 TP turning point
 USC&G US Coast & Geodetic Survey
 USGS US Geologic Survey
 VC vertical curve
 WC witness corner
 WGS World Geodetic System
 YP Cap yellow plastic cap
 Z zenith

SOIL TYPES

Cl clay
 Cl F clay fill
 Cl Hvy clay heavy
 Cl Lm clay loam
 Co S coal slack
 C Gr coarse gravel
 CS coarse sand
 FS fine sand
 Gr gravel
 Lig Co lignite coal
 Lig Sl lignite slack
 Lm loam
 Rk rock
 Sd sand
 Sdy Cl sandy clay
 Sdy Cl Lm sandy clay loam
 Sdy Fl sandy fill
 Sdy Lm sandy loam
 Sc scoria
 Sh shale
 Si Cl silt clay
 Si Cl Lm silty clay loam
 Si Lm silty loam

NORTH DAKOTA DEPARTMENT OF TRANSPORTATION	
07-01-14	
REVISIONS	
DATE	CHANGE
12-18-20	Sheet Added
4-14-25	- Continued from D-101-3 General Revisions



NDDOT UTILITY COMPANY AND ORGANIZATION ABBREVIATIONS

D-101-10

702COM 702 Communications
 ACCENT Accent Communications
 AGASSIZ WU Agassiz Water Users District
 AGC Associated General Contractors of America
 ALL PL Alliance Pipeline
 ALL SEAS WU All Seasons Water Users District
 AMOCO PI Amoco Pipeline Company
 AMRDA HESS Amerada Hess Corporation
 AT&T AT&T Corporation
 B PAW Bear Paw Energy Incorporated
 BAKER ELEC Baker Electric
 BASIN ELEC Basin Electric Cooperative Incorporated
 BEK TEL Bek Communications Cooperative
 BELLE PL Belle Fourche Pipeline Company
 BLM Bureau of Land Management
 BNSF Burlington Northern Santa Fe Railway
 BOEING Boeing
 BRNS RWD Barnes Rural Water District
 BURK-DIV ELEC Burke-Divide Electric Cooperative
 BURL WRD Burleigh County Water Resource District
 CABLE ONE Cable One
 CABLE SERV Cable Services
 CAP ELEC Capital Electric Cooperative Incorporated
 CASS CO ELEC Cass County Electric Cooperative
 CASS RWU Cass Rural Water Users District
 CAV ELEC Cavalier Rural Electric Cooperative
 CBLCOM Cablecom Of Fargo
 CENEX PL Cenex Pipeline
 CENT PL WATER DIST Central Pipe Line Water District
 CENT PWR ELEC Central Power Electric Cooperative
 CENTURYLINK CenturyLink
 COE Corps of Engineers
 CONS COMM Consolidated Communications
 CONS TELCOM Consolidated Telcom
 CONT RES Continental Resource Inc
 CPR Canadian Pacific Railway
 D O E Department Of Energy
 DAK CARR Dakota Carrier Network
 DAK CENT TEL Dakota Central Telephone
 DAK RWD Dakota Rural Water District
 DGC Dakota Gasification Company
 DICKEY R NET Dickey Rural Networks
 DICKEY WRD Dickey County Water Resource District
 DICKEY TEL Dickey Telephone
 DNRR Dakota Northern Railroad
 DOME PL Dome Pipeline Company
 DVELEC Dakota Valley Electric Cooperative
 DVMW Dakota, Missouri Valley & Western
 E CENT REG WD East Central Water District
 ENBRDG Enbridge Pipelines Incorporated
 ENVENTIS Enventis Telephone
 EQUINOR Equinor Pipeline
 FALK MNG Falkirk Mining Company
 FHWA Federal Highway Administration
 G FKS-TRL WD Grand Forks-traill Water District
 GETTY TRD & TRAN Getty Trading & Transportation
 GLDN W ELEC Golden West Electric Cooperative

GTR RAMSEY WD Greater Ramsey Water District
 GT PLNS NAT GAS Great Plains Natural Gas Company
 HALS TEL Halstad Telephone Company
 IDEA1 Idea1
 INT-COMM TEL Inter-Community Telephone Company
 KANEB PL Kaneb Pipeline Company
 KEM ELEC Kem Electric Cooperative Incorporated
 KOCH GATH SYS Koch Gathering Systems Incorporated
 LKHD PL Lakehead Pipeline Company
 LWR YELL R ELEC Lower Yellowstone Rural Electric
 LUMEN Lumen Technologies Incorporated
 MCKENZ CON McKenzie Consolidated Telcom
 MCKNZ ELEC McKenzie Electric Cooperative
 MCKNZ WRD McKenzie County Water Resource District
 MCLEOD McLeod USA
 MCLN ELEC McLean Electric Cooperative
 MCLN-SHRDN R WAT McLean-Sheridan Rural Water District
 MDU Montana-dakota Utilities
 MIDCO MidContinent Communications
 MIDSTATE TEL Midstate Telephone Company
 MINOT CABLE Minot Cable Television
 MINOT TEL Minot Telephone Company
 MISS VALL COMM Missouri Valley Communications Incorporated
 MISS W W S Missouri West Water System
 MNKOTA PWR Minnkota Power
 MOR-GRAN-SOU ELEC Mor-gran-sou Electric Cooperative
 MOUNT-WILLI ELEC Mountrail-williams Electric Cooperative
 MLGC Moore & Liberty - Griggs County
 MUNICIPAL City Water And Sewer
 MUNICIPAL City Of '.....'
 N CENT ELEC North Central Electric Cooperative
 N PRAIR REG WD North Prairie Regional Water District
 ND PKS & REC North Dakota Parks And Recreation
 ND TEL North Dakota Telephone Company
 NDDOT North Dakota Department of Transportation
 NE REG WD Northeast Regional Water District
 NDSU SOIL SCI DEPT NDSU Soil Science Department
 NEMONT TEL Nemont Telephone
 NODAK R ELEC Nodak Rural Electric Cooperative
 NOON FRMS TEL Noonan Farmers Telephone Company
 NPR Northern Plains Railroad
 NSP Northern States Power
 NTHN BRDR PL Northern Border Pipeline
 NTHN PLNS ELEC Northern Plains Electric Cooperative Incorporated
 NTHWSTRN REF Northwestern Refinery Company
 NW COMM Northwest Communication Cooperation
 NWRWD Northwest Rural Water District
 ONEOK Oneok gas
 OSHA Occupational Safety and Health Administration
 OTTR TL PWR Otter Tail Power Company
 PAAP Plains All American Pipeline
 P L E M Prairielands Energy Marketing
 POLAR COM Polar Communications
 PVT ELEC Private Electric
 QWEST Qwest Communications
 R&T REG WD R & T Water District

RED RIV COMM Red River Communications
 RESVTN TEL Reservation Telephone
 ROBRTS TEL Roberts Company Telephone
 R-RIDER ELEC Roughrider Electric Cooperative
 RRVW Red River Valley & Western Railroad
 S CENT REG WD South Central Regional Water District
 SE W U Southeast Water Users Incorporated
 SCOTT CABLE Scott Cable Television Dickinson
 SHERDN ELEC Sheridan Electric Cooperative
 SHEYN VLY ELEC Sheyenne Valley Electric Cooperative
 SKYTECH Skyland Technologies Incorporated
 SLOPE ELEC Slope Electric Cooperative Incorporated
 SOURIS RIV TELCOM Souris River Telecommunications
 ST WAT COMM State Water Commission
 STATE LN WATER State Line Water Cooperative
 STER ENG Sterling Energy
 STUT RWD Stutsman Rural Water District
 SW PL PRJ Southwest Pipeline Project
 SWWA Southwest Water Authority
 SUNOCO Sunoco LP
 T M C Turtle Mountain Communications
 TCI TCI of North Dakota
 TESORO GHG PLNS PL Tesoro High Plains Pipeline
 TRI-CNTY WU Tri-County Water Users Incorporated
 TRL CO WRD Traill County Water Resource District
 UNTD TEL United Telephone
 UPPR SOUR WD Upper Souris Water District
 US SPRINT U.S. Sprint
 USAF MSL CABLE U.S.A.F. Missile Cable
 USFWS US Fish and Wildlife Service
 USW COMM U.S. West Communications
 VRNDRY ELEC Verendrye Electric Cooperative
 W RIV TEL West River Telephone Incorporated
 WAPA Western Area Power Administration
 WAWSA Western Area Water Supply Authority
 WEB W. E. B. Water Development Association
 WILLI WRD Williams County Water Resource District
 WILSTN BAS PL Williston Basin Interstate Pipeline Company
 WLSH RWD Walsh Water Rural Water District
 WOLVRTN TEL Wolverton Telephone
 XLENER Xcel Energy
 YSVR Yellowstone Valley Railroad

NORTH DAKOTA DEPARTMENT OF TRANSPORTATION	
07-01-14	
REVISIONS	
DATE	CHANGE
04-23-18	General Revisions
05-20-18	General Revisions
12-18-20	General Revisions
08-16-22	General Revisions
04-14-25	General Revisions



LINE STYLES

D-101-20

Existing Topography

- Void — Void — Void — V Existing Ground Void
- + — + — Existing Cemetary Boundary
- - - - - Existing Box Culvert Bridge
- - - - - Existing Concrete Surface
- - - - - Existing Drainage Structure
- — — — — Existing Gravel Surface
- — — — — Existing Riprap
- — — — — Existing Dirt Surface
- — — — — Existing Asphalt Surface
- — — — — Existing Tie Point Line
- - - - - Existing Railroad Centerline
- . - . - . Existing Guardrail Cable
- • — • — • Existing Guardrail Metal
- . — . — . Existing Edge of Water
- - - - -x- - - - -x- Existing Fence
- | | | | | Existing Railroad
- Existing Field Line
- ~ ~ ~ ~ ~ Exst Flow
- ===== Existing Curb
- - - - - Existing Valley Gutter
- - - - - Existing Driveway Gutter
- ===== Existing Curb and Gutter
- ===== Existing Mountable Curb and Gutter

Proposed Topography

- - - - - Existing 3-Cable w Posts
- — — — — Site Boundary
- Existing Berm, Dike, Pit, or Earth Dam
- Existing Ditch Block
- ~ ~ ~ ~ ~ Existing Tree Boundary
- ===== Existing Brush or Shrub Boundary
- . - . - . Existing Retaining Wall
- — — — — Existing Planter or Wall
- — — — — Existing W-Beam Guardrail with Posts
- — — — — Existing Railroad Switch
- ~ ~ ~ ~ ~ Gravel Pit - Borrow Area
- - - - - Existing Wet Area-Vegetation Break
- - - - - Existing High Tension Cable Guardrail
- • - • - • Existing High Tension Cable Guardrail with Posts
- — — — — 3-Cable w Posts
- ~ ~ ~ ~ ~ Flow
- x- - - - -x- Fence
- REMOVE — REMOVE — Remove Line
- ===== Wall
- ~ ~ ~ ~ ~ Retaining Wall (Plan View)
- — — — — W-Beam w Posts
- — • — • High Tension Cable Guardrail with Posts

Existing Utilities

- — — — — E — Existing Electrical
- — — — — FO — Existing Fiber Optic Line
- — — — — FO — Existing TV Fiber Optic
- — — — — G — Existing Gas Pipe
- — — — — OH — Existing Overhead Utility Line
- — — — — P — Existing Power
- — — — — PL — Existing Fuel Pipeline
- — — — — PL — Existing Undefined Above Ground Pipe Line
- - - - - SAN - - - - - Existing Sanitary Sewer
- - - - - SAN FM - - - - - Existing Sanitary Force Main
- - - - - SD - - - - - Existing Storm Drain
- - - - - SD FM - - - - - Existing Storm Drain Force Main
- - - - - Existing Culvert
- — — — — T — Existing Telephone Line
- — — — — TV — Existing TV Line
- — — — — W — Existing Water or Steam Line
- ===== Existing Under Drain
- ===== Existing Slotted Drain
- — — — — Existing Conduit
- - - - - Existing Conductor
- — — — — Existing Down Guy Wire Down Guy
- — — — — Existing Underground Vault or Lift Station

Proposed Utilities

- ===== 24 Inch Pipe
- ===== Reinforced Concrete Pipe
- ===== Under Drain
- - - - - Edge Drain

Traffic Utilities

- - - - - Conductor
- - - - - Fiber Optic
- - - - - Existing Loop Detector
- — — — — Existing Double Micro Loop Detector
- — — — — Micro Loop Detector Double
- — — — — Existing Micro Loop Detector
- — — — — Micro Loop Detector
- ↓ — — — — Signal Head with Mast Arm
- ↓ — — — — Existing Signal Head with Mast Arm

Sign Structures

- — — — — Existing Overhead Sign Structure
- — — — — Existing Overhead Sign Structure Cantilever
- — — — — Overhead Sign Structure Cantilever

NORTH DAKOTA DEPARTMENT OF TRANSPORTATION	
07-01-14	
REVISIONS	
DATE	CHANGE
09-23-16	Added and Revised Items, Organized by Functional Groups
12-18-20	General Revisions

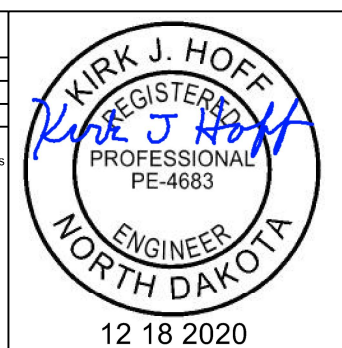

LINE STYLES

D-101-21

Right Of Way

- Easement
- Existing Easement
- Right of Way
- Existing Right of Way
- Existing Right of Way Railroad
- Existing Right of Way Not State Owned
- Existing Government Lot Line
- Existing Adjacent Block Lines
- Existing Adjacent Lot Lines
- Existing Adjacent Property Line
- Existing Adjacent Subdivision Lines
- Sight Distance Triangle Line
- Dimension Leader

Boundary Control

- ////// Existing City Corporate Limits or Reservation Boundary
- Existing State or International Line
- Existing Township
- Existing County
- Existing Section Line
- Existing Quarter Section Line
- Existing Sixteenth Section Line
- Existing Centerline
- Tangent Line

Cross Sections and Typical

- Existing Ground
- Existing Topsoil (Cross Section View)
- void - void - void - v Existing Ground Void (Not Surveyed)
- Existing Concrete
- Existing Aggregate (Cross Section View)
- Existing Curb and Gutter (Cross Section View)
- Existing Asphalt (Cross Section View)
- Existing Reinforcement Rebar

Geotechnical

- D ----- D ----- Geotextile Fabric Type D
- **Geo** ----- **Geo** ----- Geogrid
- R ----- R ----- Geotextile Fabric Type R
- R ----- R ----- Geotextile Fabric Type R1
- RR ----- RR ----- Geotextile Fabric Type RR
- S ----- S ----- Geotextile Fabric Type S

Countours

- Depression Contours
- Supplemental Contour

Profile

- Subgrade, Subcut or Ditch Grade
- Topsoil Profile

Striping

- Centerline Pavement Marking
- ===== Barrier with Centerline Pavement Marking
- ===== Barrier Pavement Marking
- - - - - Stripe 4 IN Dotted Extension White
- - - - - Stripe 8 IN Dotted Extension White
- - - - - Stripe 8 IN Lane Drop

Pavement Joints

- ===== Doweled Joint
- +++++ Tie Bar 30 Inch 4 Foot Center to Center
- +++++ Tie Bar 18 Inch 3 Foot Center to Center
- +++++ Tie Bar at Random Spacing

Bridge Details

- Small Hidden Object
- Large Hidden Object
- Phantom Object
- Existing Conditions Object
- Centerline Main
- Centerline Secondary
- Excavation Limits
- Proposed Ground
- ~~~~~ Sheet Piling

Erosion Control

- Limits of Const Transition Line
- Bale Check
- Rock Check
- s ----- s ----- Floating Silt Curtain
- SF ----- SF ----- Silt Fence
- Excavation Limits
- Fiber Rolls











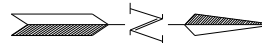

















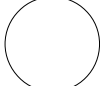









Environmental

- Wetland Mitigation
- Existing Wetland Easement USFWS
- Existing Wetland Jurisdictional
- Existing Wetland
- Tree Row

NORTH DAKOTA DEPARTMENT OF TRANSPORTATION	
07-01-14	
REVISIONS	
DATE	CHANGE
09-23-16 12-18-20	Added and Revised Items, Organized by Functional Groups General Revisions



SYMBOLS

















































































	North Arrow (Half Scale)		Existing Bush or Shrub		Continuous Split Barrel Sample
	Alignment Data Point		Existing Large Evergreen Tree		Flight Auger Sample
	Alignment Monument		Existing Small Evergreen Tree		Split Barrel Sample
	Spot Elevation		Existing Large Tree		Thinwall Tube Sample
	Existing Miscellaneous Spot		Existing Small Tree		Standard Penetration Test
	Existing Access Control Arrow		Existing Tree Trunk		Inclinometer Tube
	Existing Benchmark		Cairn or Stone Circle		Excavation Unit
	Reset USGS Marker		Existing Artifact		Existing Ground Water Well Bore Hole
	Iron Monument Found		Existing Satellite Dish		
	Iron Pin R/W Monument		Existing Weather Station		
	Property Corner		Existing Windmill or Tower		
	Iron Pin Reference Monument		Reinforced Pavement		
	Right of Way Marker (Exst, Ppsd, Reset)				
	Existing Federal Reference Corner				
	Existing Section Corner (Full, Quarter, Sixteenth, Meander)				
	Existing Witness Corner				
	Existing Control Point (CP, GPS-RTK, TRI)				
	Existing Traverse PI Aerial Panel				
	Existing Reference Marker Point NGS				
	Existing EFB Misc				

NORTH DAKOTA DEPARTMENT OF TRANSPORTATION		
07-01-14		
REVISIONS		
DATE	CHANGE	
12-18-20	General Revisions	

12 18 2020

SYMBOLS

D-101-32

 Existing Luminaire  Luminaire LED  Existing Light Standard Luminaire  Relocate Light Standard  Light Standard Light LED Luminaire  Light Standard 35 Watt High Pressure Sodium Vapor Luminaire  Light Standard 50 Watt High Pressure Sodium Vapor Luminaire  Light Standard 70 Watt High Pressure Sodium Vapor Luminaire  Light Standard 100 Watt High Pressure Sodium Vapor Luminaire  Light Standard 150 Watt High Pressure Sodium Vapor Luminaire  Light Standard 200 Watt High Pressure Sodium Vapor Luminaire  Light Standard 250 Watt High Pressure Sodium Vapor Luminaire  Light Standard 310 Watt High Pressure Sodium Vapor Luminaire  Light Standard 400 Watt High Pressure Sodium Vapor Luminaire  Light Standard 700 Watt High Pressure Sodium Vapor Luminaire  Light Standard 1000 Watt High Pressure Sodium Vapor Luminaire  Emergency Vehicle Detector  Video Detection Camera	  High Mast Light Standard 3 Luminaire (Exst, Ppsd)   High Mast Light Standard 4 Luminaire (Exst, Ppsd)   High Mast Light Standard 5 Luminaire (Exst, Ppsd)   High Mast Light Standard 6 Luminaire (Exst, Ppsd)   High Mast Light Standard 7 Luminaire (Exst, Ppsd)   High Mast Light Standard 8 Luminaire (Exst, Ppsd)   High Mast Light Standard 9 Luminaire (Exst, Ppsd)   High Mast Light Standard 10 Luminaire (Exst, Ppsd)   Overhead Sign Structure Load Center (Exst, Ppsd)   Traffic Signal Controller (Exst, Ppsd)   Pad Mounted Traffic Signal Controller (Exst, Ppsd)   Flashing Beacon (Exst, Ppsd)   Concrete Foundation (Exst, Ppsd)   Pipe Mounted Flasher (Exst, Ppsd)   Pad Mounted Feed Point (Exst, Ppsd)   Pipe Mounted Feed Point with Pad (Exst, Ppsd)   Pole Mounted Feed Point (Exst, Ppsd)   Junction Box (Exst, Ppsd)  Existing Pedestrian Head with Number  Existing Signal Head  Pole Mounted Head  Existing Lighting Standard Pole	 Existing Traffic Signal Standard    Pull Box (Exst-Ppsd-Undefined)   Intelligent Transportation Pull Box (Exst, Ppsd)   Transformer (Exst, Ppsd)    Power Pole (Exst-Ppsd-with Transformer)   Wood Pole (Exst, Ppsd)   Pedestrian Push Button Post (Exst, Ppsd)  Existing Pole  Existing Telephone Pole  Existing Post     Connection Conductor (Ground, Neutral, Phase 1, Phase 2)
---	---	--

NORTH DAKOTA DEPARTMENT OF TRANSPORTATION	
07-01-14	
REVISIONS	
DATE	CHANGE
12-18-20	General Revisions



KIRK J. HOFF

REGISTERED

PROFESSIONAL

PE-4683

ENGINEER

NORTH DAKOTA

12 18 2020

Cross Section Legend

Description	Longitudinal Parallel to Roadway	Transverse Perpendicular to Roadway*
Cable Line	● CBL1	● CBL2
Conduit Line	● CDU1	● CDU2
Electric Line	● E1	● E2
Fiber Optic Line	● F1	● F2
Gas Main Line	● GM1	● GM2
Gas Service Line	● GS1	● GS2
Gas Transmission Line	● GT1	● GT2
Fuel Pipeline	● PL1	● PL2
Sanitary Sewer Force Main	● SSF1	● SSF2
Sanitary Sewer	● SS1	● SS2
Steam Line	● STE1	● STE2
Storm Drain (Assumed Depth)	● SD1	● SD2
Telephone Line	● T1	● T2
TV Line	● TV1	● TV2
Water Main Line	● WM1	● WM2
Water Service Line	● WS1	● WS2

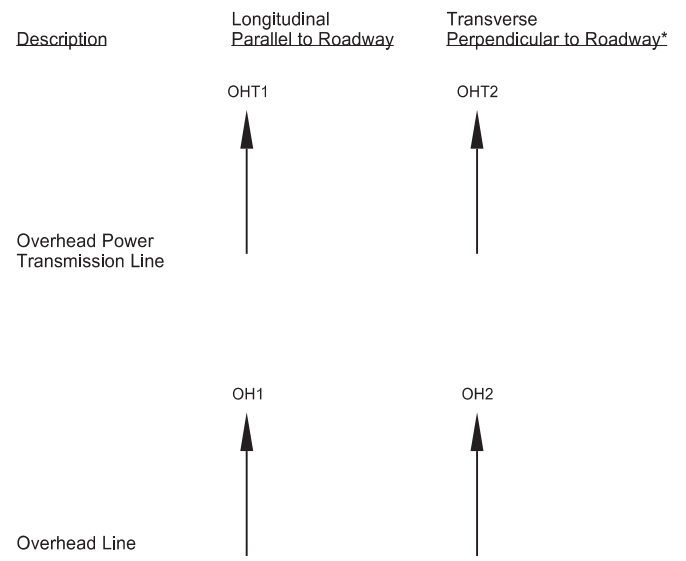

Light Standard - Multiple Variations
Concrete
Steel
Wood
with Traffic Signal

Pole - Multiple Variations
Utility
Brace
Feed Point
Guy
Power
Power Structure
Power with Light
Power with Transformer

Manhole - Multiple Variations
Electric
Fiber Optic
Gas
Inlet
Sanitary Force Main
Sanitary
Sanitary with Valve
Steam
Storm
Storm Force Main
Storm with Valve
Telephone
Water
Water with Meter
Water with Valve
Water with Air Release Valve

Anchor

High Tension Cable Guardrail

* Usually the transverse utilities are shown on a cross section with 2 or more symbols. The utility runs from one symbol to the other, but the connection may not be shown.

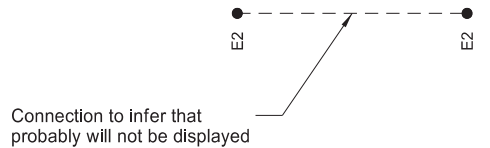

When storm drain invert elevations are NOT used to draw pipe, they will appear as shown to the left. When invert elevations are used to draw pipe, they will be a cross section similar to the graphics shown below.

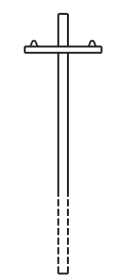

NORTH DAKOTA DEPARTMENT OF TRANSPORTATION	
9-20-18	
REVISIONS	
DATE	CHANGE
6/14/2023	CADD Standards Update



06/14/23

TRANSVERSE CONTRACTION JOINT DETAILS

Notes

1. The joint seal details apply to both doweled and non-doweled (plain) transverse joints.
2. T = Thickness of pavement.
3. $B = T/4 + 1/4"$ for AE or non-dowelled concrete pavement or $B = T/3$ for AAE or dowelled concrete pavement

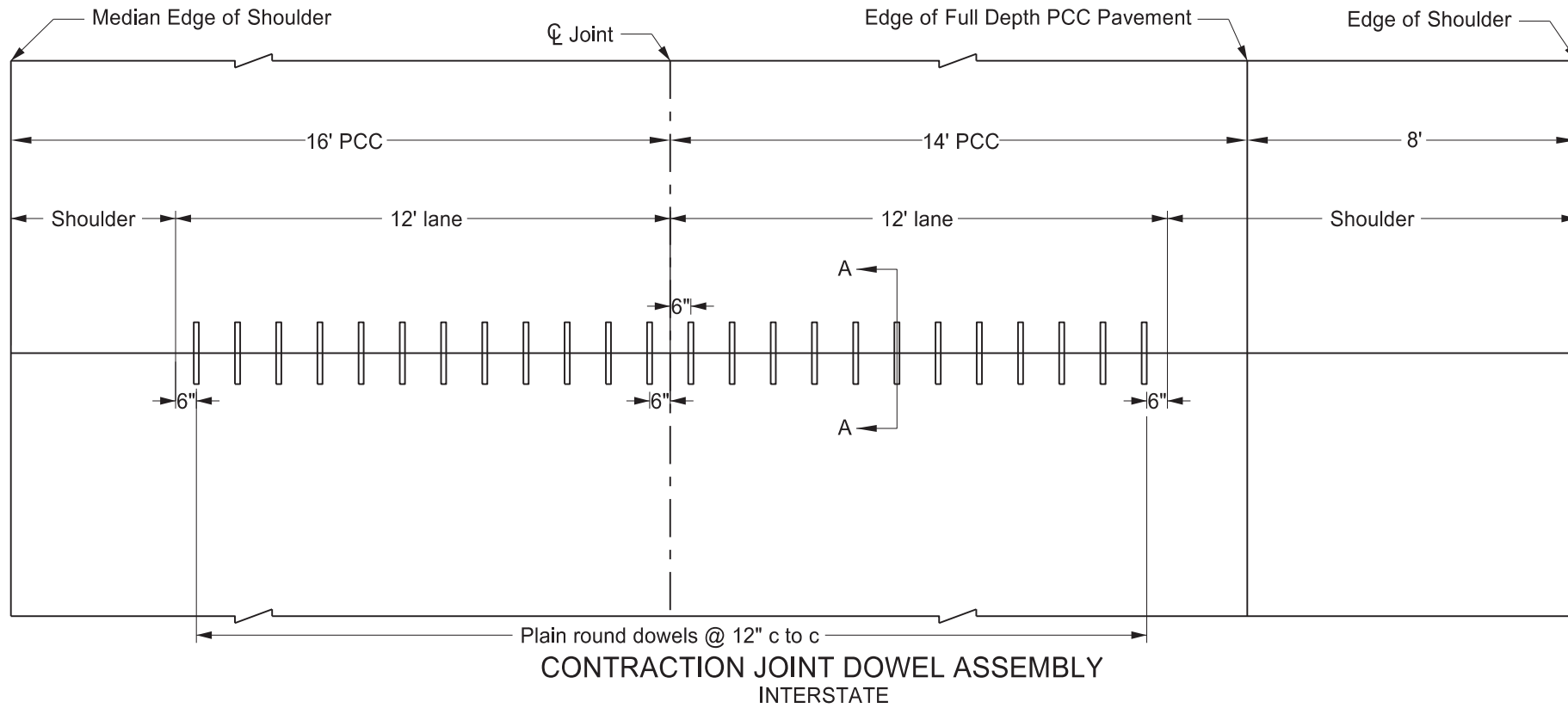
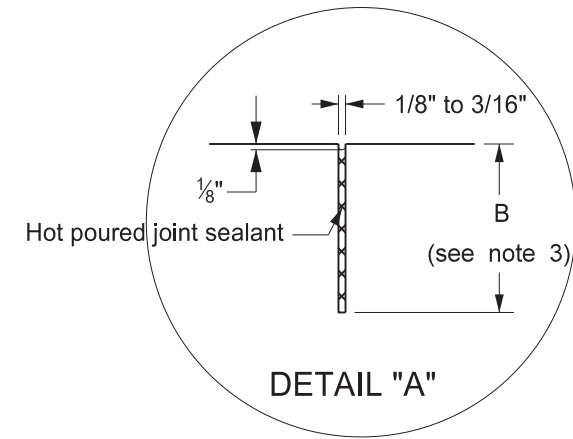

Sawed and sealed transverse contraction joint (see DETAIL "A")

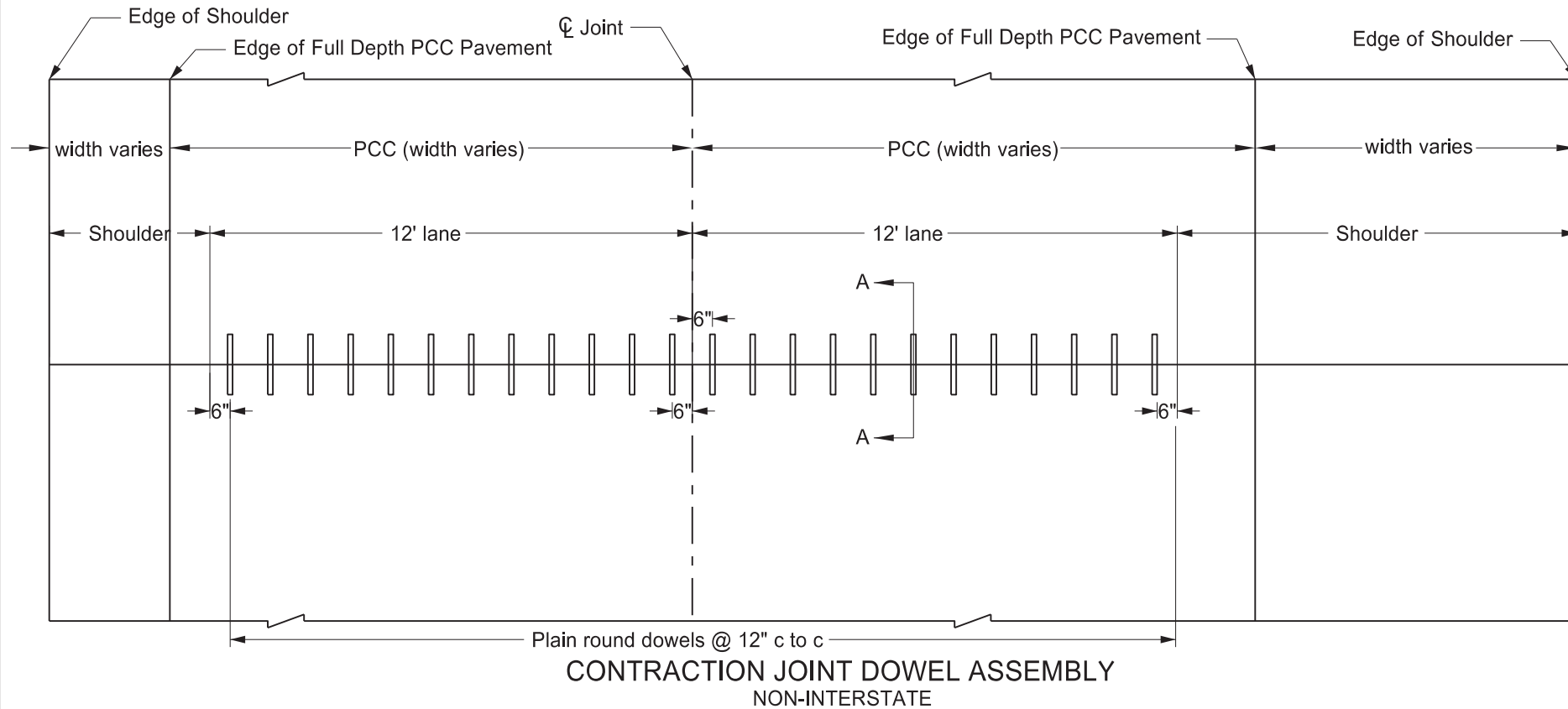
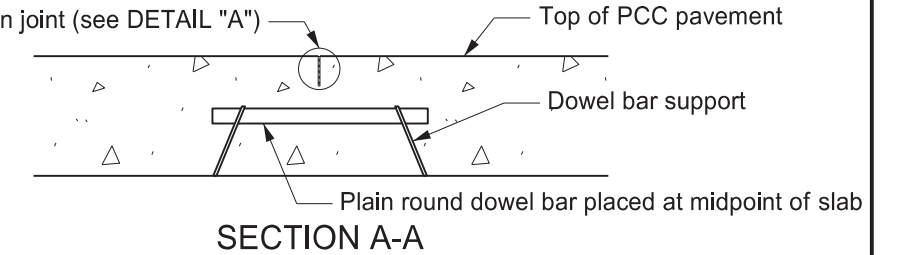

NORTH DAKOTA DEPARTMENT OF TRANSPORTATION	
9-15-10	
REVISIONS	
DATE	CHANGE
6/23/2014	Removed dowel size reference
3/16/2016	Revised Joint Details and notes
10/25/2019	Expanded Details for clarity
03/13/2025	Revised # of Dowels & Note 3.

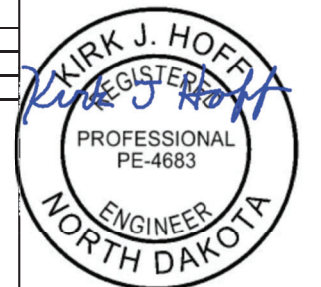

03/13/25

TRANSVERSE EXPANSION JOINT DETAIL

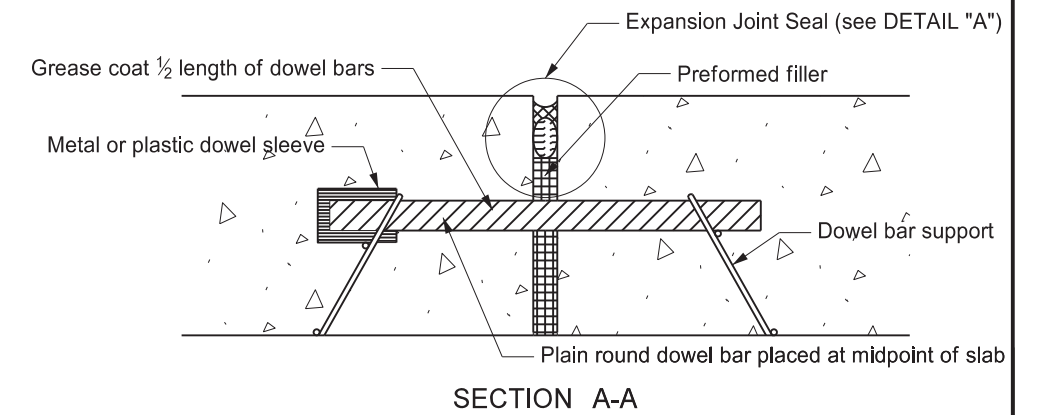
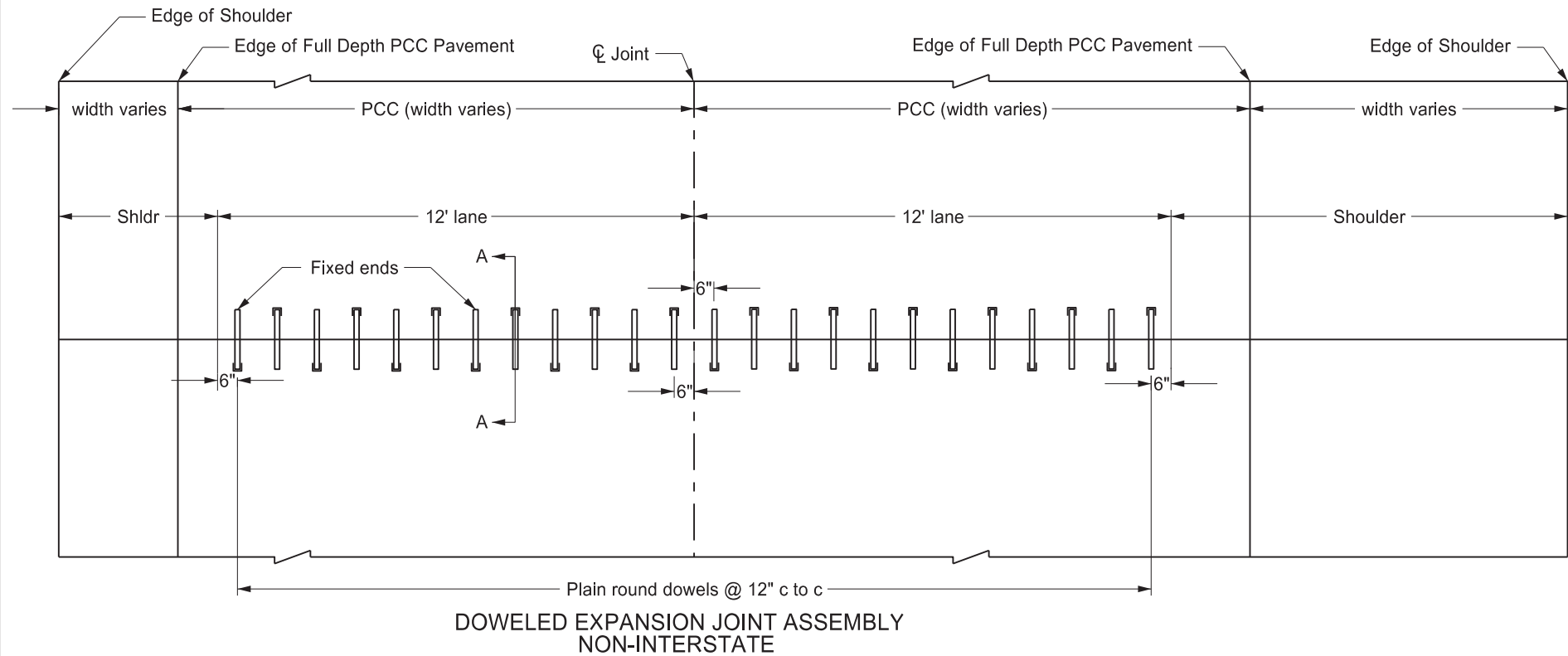
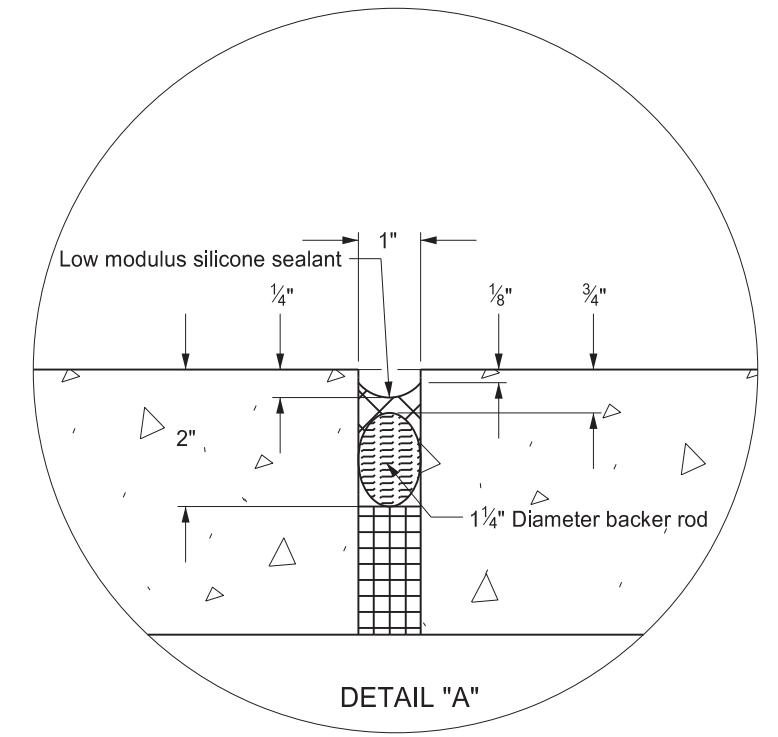
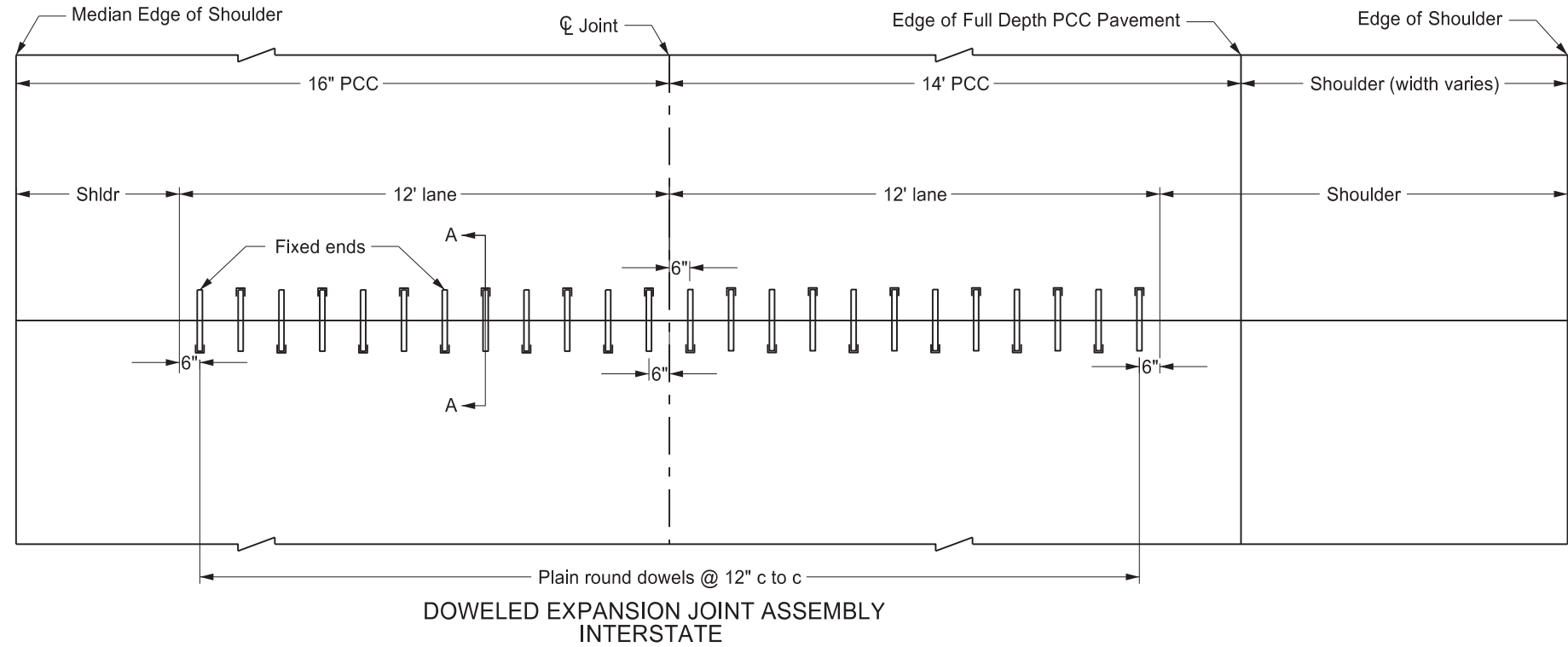

NORTH DAKOTA DEPARTMENT OF TRANSPORTATION	
9-15-2010	
REVISIONS	
DATE	CHANGE
6/23/2014	Removed dowel bar sizes
10/25/2019	Expanded details for clarity
3/13/2025	Revised # of dowels.



03/13/25

TRANSVERSE CONSTRUCTION JOINT

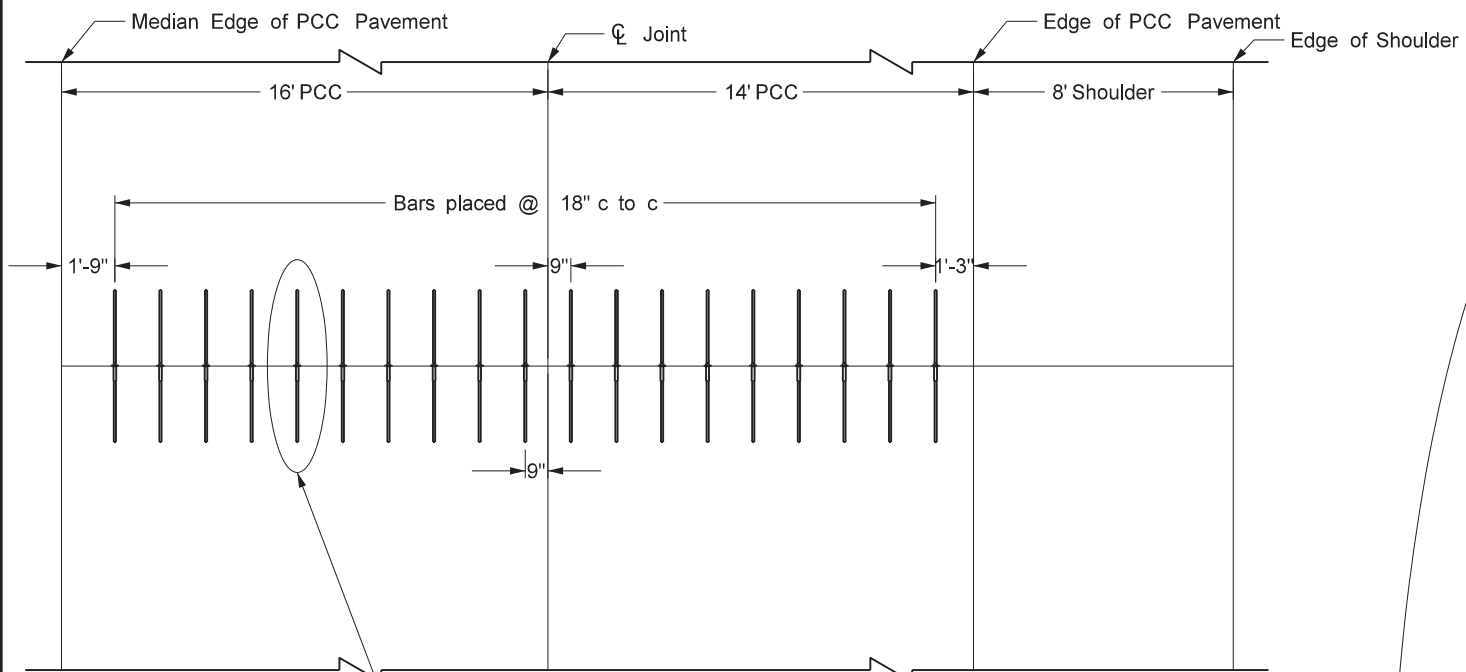

See "DEFORMED SPLICER BAR", "DETAIL A", "DETAIL B" and "STAGES OF CONSTRUCTION" drawings, this standard

PLAN VIEW

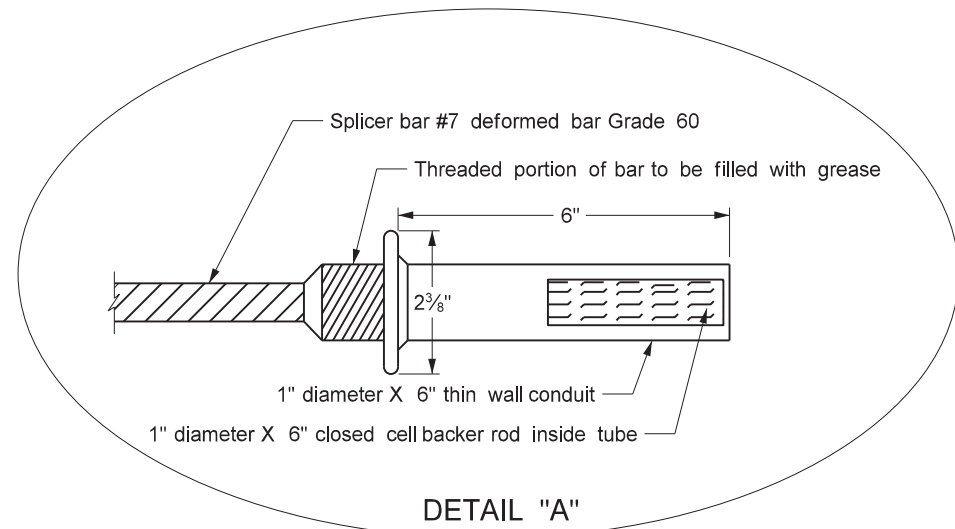

DETAIL "A"

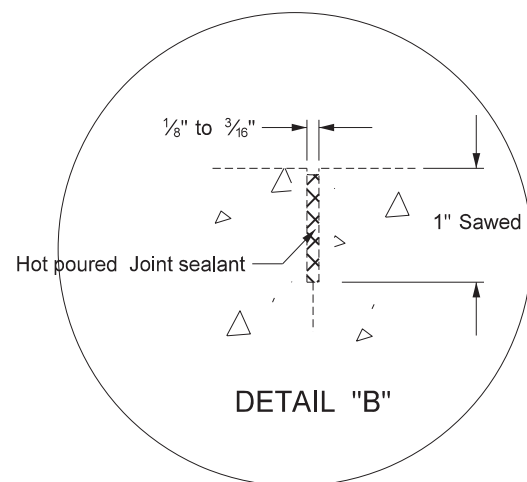

DETAIL "B"

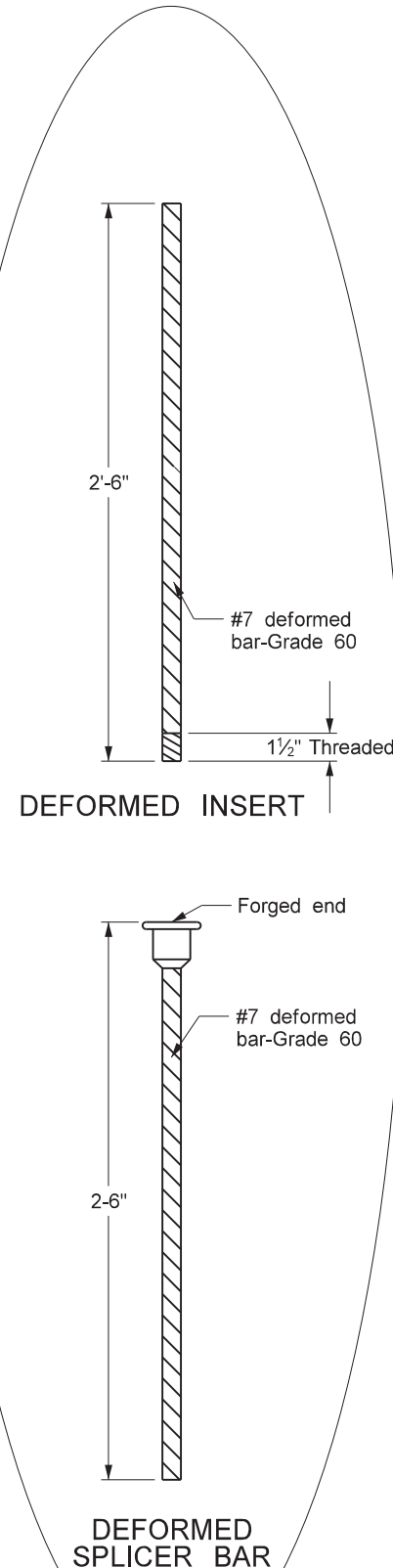

DEFORMED INSERT

DEFORMED SPLICER BAR

STAGES OF CONSTRUCTION

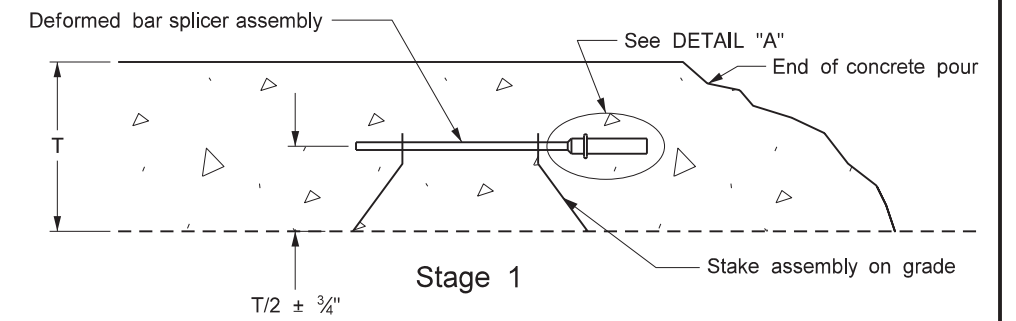

Stage 1

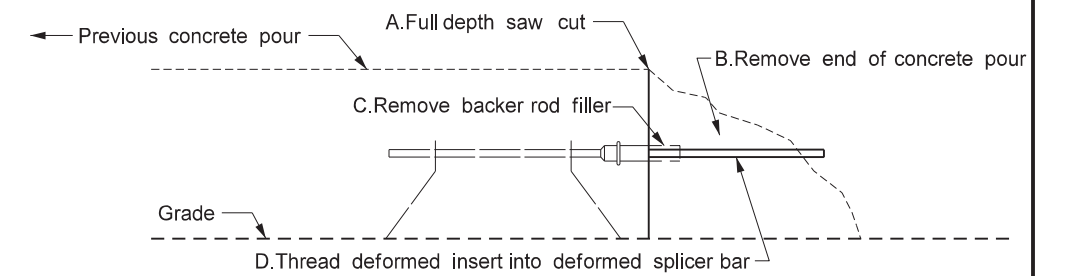

Stage 2

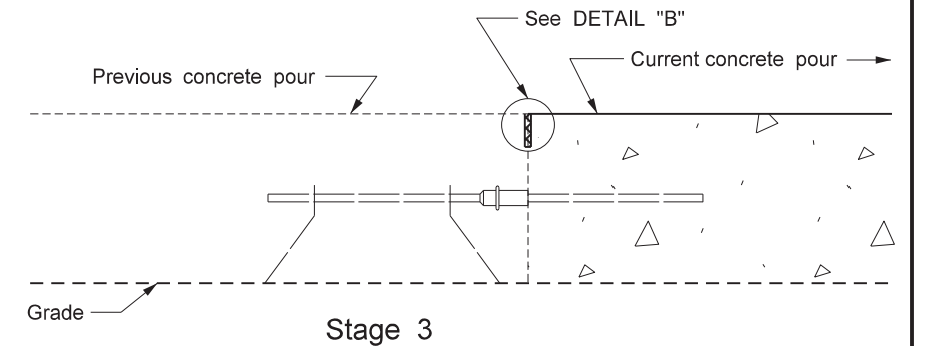

Stage 3

Notes

1. Saw and seal all construction joints.
2. Include all costs for transverse construction joints in the price bid for PCC pavement.
3. Do not saturate the subgrade during the sawing operation.

NORTH DAKOTA DEPARTMENT OF TRANSPORTATION	
9-15-2010	
REVISIONS	
DATE	CHANGE
3-16-16	Revised Joint Details & notes.
8-27-19	New Design Engr PE Stamp.
8-09-24	Electronic Stamp/Signature.



08/09/24

BREAKAWAY SYSTEMS FOR CONSTRUCTION ZONE SIGNS

D-704-7

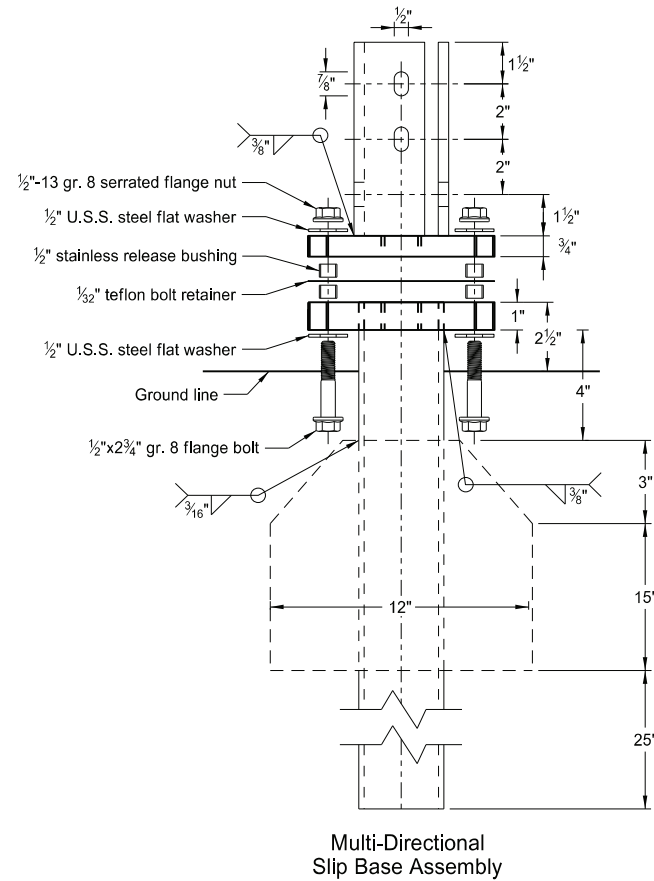

Perforated Tube

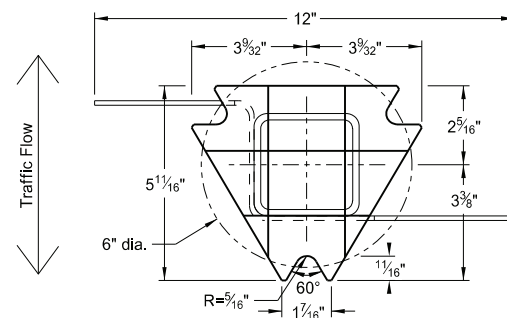
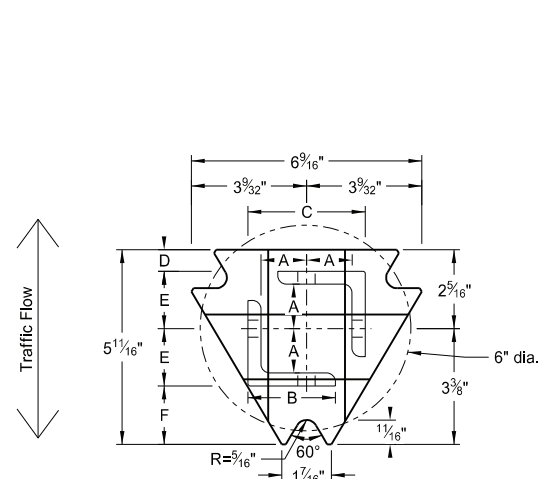

Bottom Soil Stub

Tube - 3"x3"x7 gauge ASTM A500 grade B tube
Stabilizing Wing - 7 gauge H.R.P.O. ASTM A1011
Plate - ASTM A572 grade 50

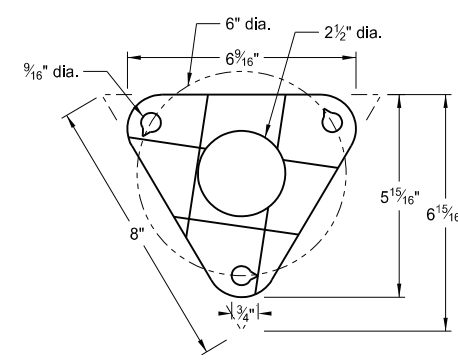

Notes:

1. Torque slip base bolts as specified by manufacturer.
2. Use anchor with 43.9 KSI yield strength and 59.3 KSI tensile strength.
3. Provide 4" vertical clearance for anchor or breakaway base. Measure the 4"x60" measurement above and below post location and back and ahead of post.
4. In concrete sidewalk, use same anchor without wings.
5. Provide more than 7' between the first and fourth posts of a four post sign.

Telescoping Perforated Tube

Number of Posts	Post Size in.	Wall Thickness Gauge	Sleeve Size in.	Wall Thickness Gauge	Slip Base	Anchor Size without Slip Base in.
1	2	12			No	2 1/4
1	2 1/4	12			No	2 1/2
1	2 1/2	12			(A)	3
1	2 1/2	10			Yes	
1	2 1/4	12	2	12	Yes	
1	2 1/2	12	2 1/4	12	Yes	
2	2	12			No	2 1/4
2	2 1/4	12			No	2 1/2
2	2 1/2	12			Yes	
2	2 1/2	12			Yes	
2	2 1/4	10	2	12	Yes	
3 & 4	2 1/2	12			Yes	
3 & 4	2 1/2	10			Yes	
3 & 4	2 1/2	12	2 1/4	12	Yes	
3 & 4	2 1/4	12	2	12	Yes	
3 & 4	2 1/2	10	2 3/16	10	Yes	

Properties of Telescoping Perforated Tube

Tube Size in.	Wall Thickness in.	U.S. Standard Gauge	Weight per Foot lbs.	Moment of Inertia in. ⁴	Cross Sec. Area in. ²	Section Modulus in. ³
1 1/2 x 1 1/2	0.105	12	1.702	0.129	0.380	0.172
2 x 2	0.105	12	2.416	0.372	0.590	0.372
2 1/4 x 2 1/4	0.105	12	2.773	0.561	0.695	0.499
2 3/16 x 2 3/16	0.135	10	3.432	0.605	0.841	0.590
2 1/2 x 2 1/2	0.105	12	3.141	0.804	0.803	0.643
2 1/2 x 2 1/2	0.135	10	4.006	0.979	1.010	0.785

Top Post Receiver Data Table

Square Post Sizes (B)	A	B	C	D	E	F
2 3/16"x10 ga.	1 5/64"	2 1/2"	3 1/32"	2 5/32"	1 33/64"	1 7/8"
2 1/2"x10 ga.	1 3/32"	2 1/2"	3 5/16"	5/8"	1 21/32"	1 3/4"

- (A) Use breakaway base when support is placed in weak soils. Engineer determines if soils are weak.
- (B) For additional wind load, insert the 2 3/16"x10 ga. into 2 1/2"x10 ga.

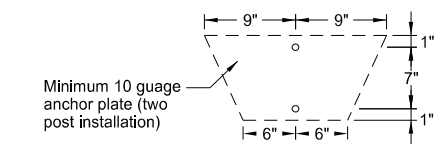
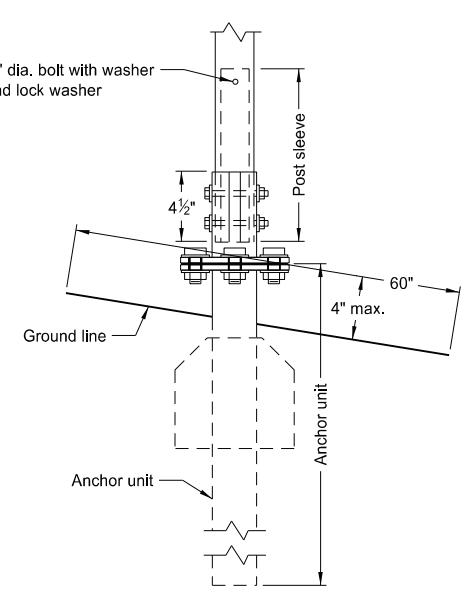
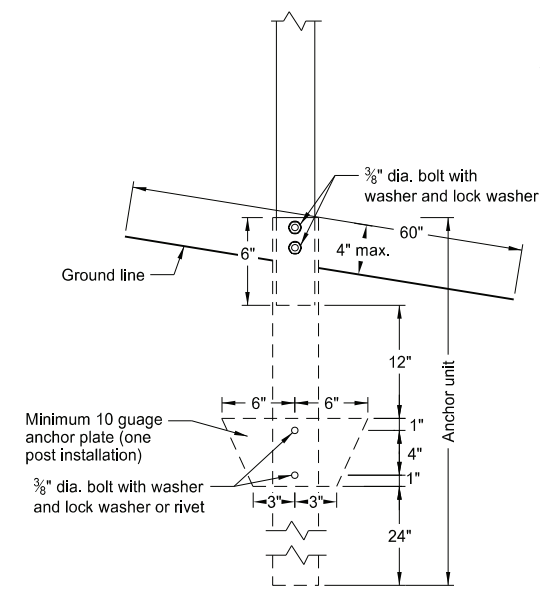

NORTH DAKOTA DEPARTMENT OF TRANSPORTATION	
2-28-14	
REVISIONS	
DATE	CHANGE
9-27-17	Updated to active voice
10-03-19	New Design Engr PE Stamp
8-01-24	Electronic Stamp/Signature



BREAKAWAY SYSTEMS FOR CONSTRUCTION ZONE SIGNS

D-704-8

U-Channel Post

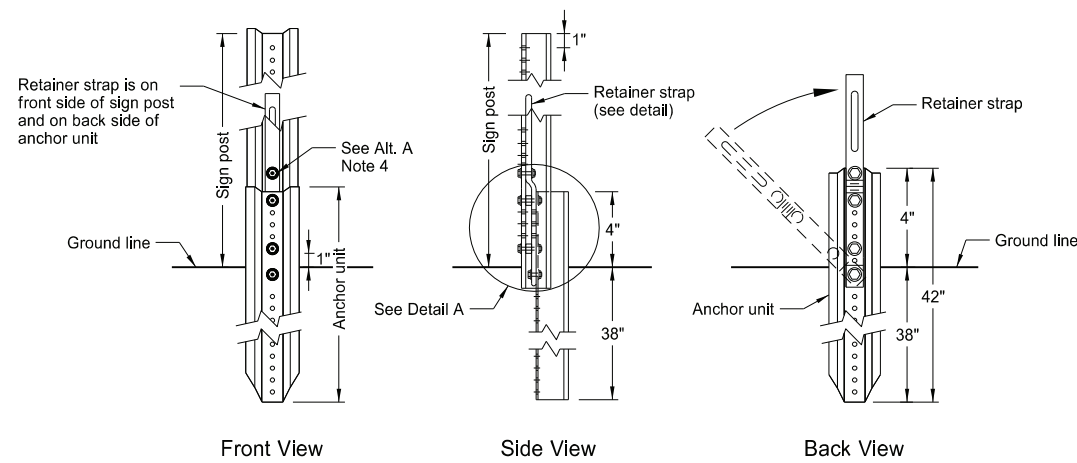
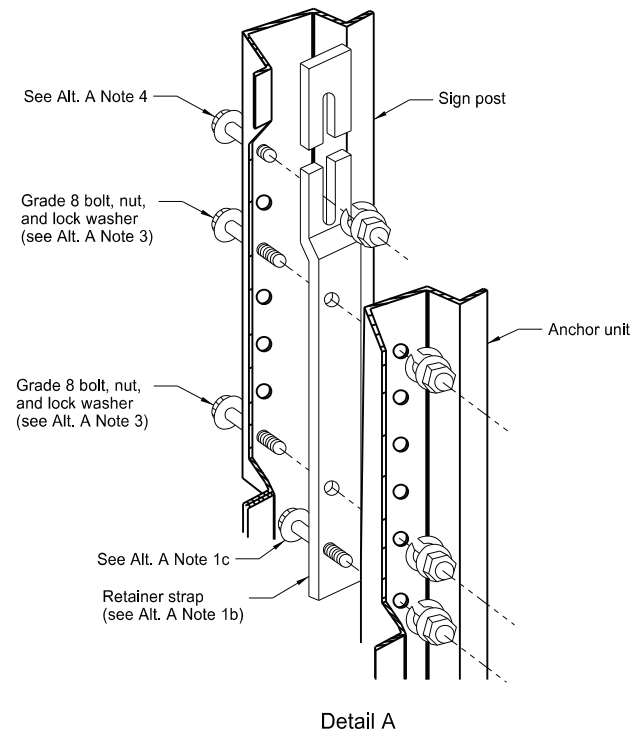

Breakaway U-Channel Detail Alternate A
Install a maximum of 2 posts within 7'.

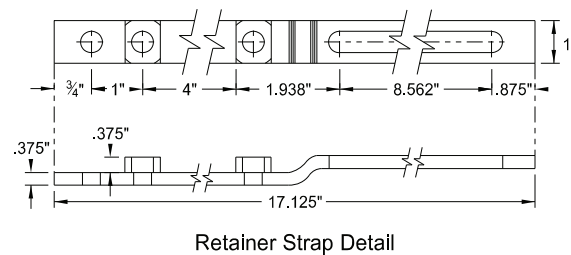

Retainer Strap Detail

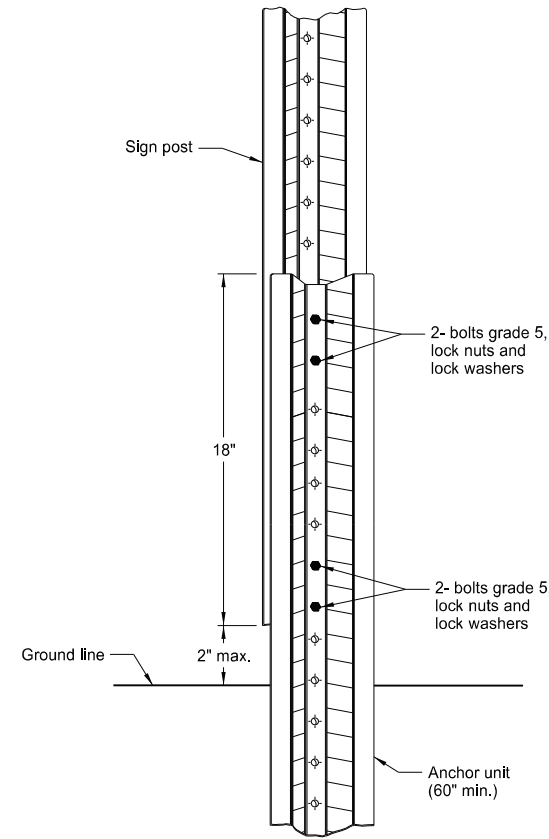

Breakaway U-Channel Splice Detail Alternate B
(2.5 and 3 lb/ft)
Install a maximum of 3 posts within 7'.

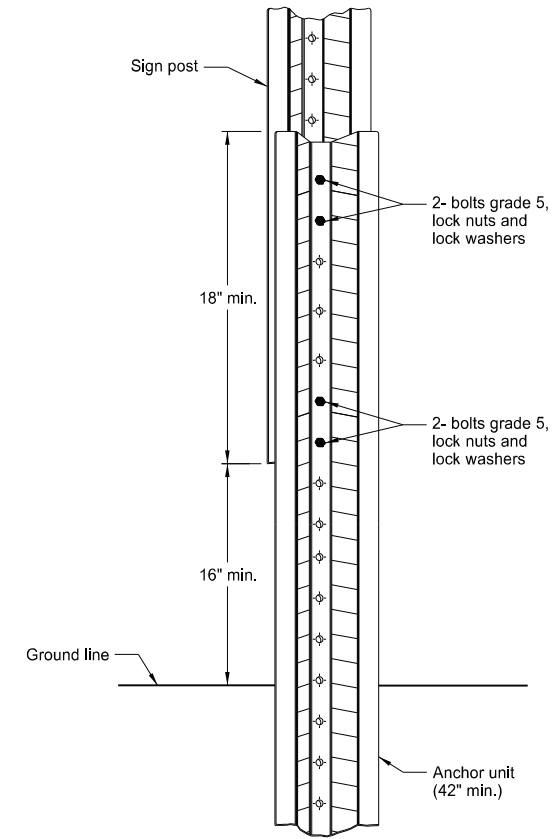

Breakaway U-Channel Splice Detail Alternate C
(2.5 and 3 lb/ft)
Install a maximum of 3 posts within 7'.

Alternate A Steps of Installation:

- Drive anchor unit to within 12" of ground level.
 - Establish proper assembly by lining up bottom hole of retainer strap with 6th hole from the top of the anchor unit.
 - Assemble strap to back of anchor unit using 5/16"x2" bolt, lock washer and nut.
 - Rotate strap 90° to left.
- Drive anchor unit to 4" above ground.
 - Rotate strap to vertical position.
- Place 5/16"x2" bolt, lock washer and nut in bottom of sign post to facilitate alignment of sign post with proper hole in anchor unit.
 - Alternately tighten two connector bolts.
- Complete assembly by tightening 5/16"x2" bolt (this fastens sign post to retainer strap).
- Properly nest base post, strap, and sign post. Proper nesting occurs when all flat surfaces of the base post, strap, and sign post at the bolts have full contact across the entire width.

NORTH DAKOTA DEPARTMENT OF TRANSPORTATION	
2-28-14	
REVISIONS	
DATE	CHANGE
9-27-17	Updated to active voice
10-03-19	New Design Engr PE Stamp
8-01-24	Electronic Stamp/Signature



08/01/24

CONSTRUCTION SIGN DETAILS
TERMINAL AND GUIDE SIGNS

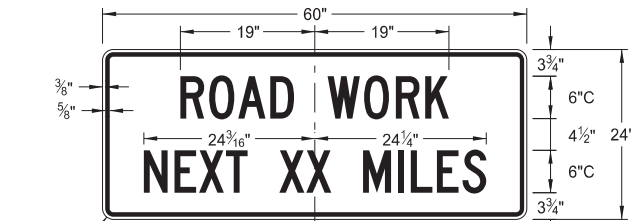

G20-1-60
Legend: black (non-refl)
Background: orange

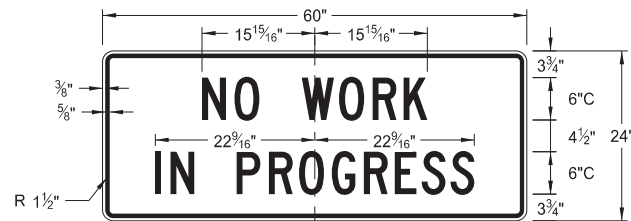

G20-1b-60
Legend: black (non-refl)
Background: orange

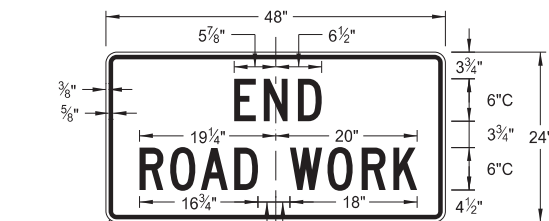

G20-2-48
Legend: black (non-refl)
Background: orange

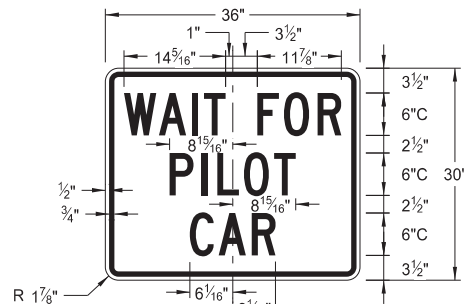

G20-4b-36
Legend: black (non-refl)
Background: orange

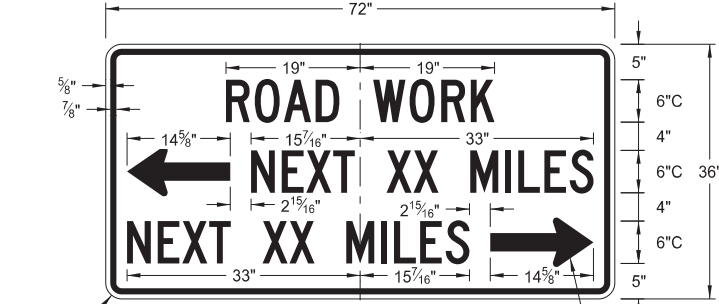

G20-50a-72
Legend: black (non-refl)
Background: orange

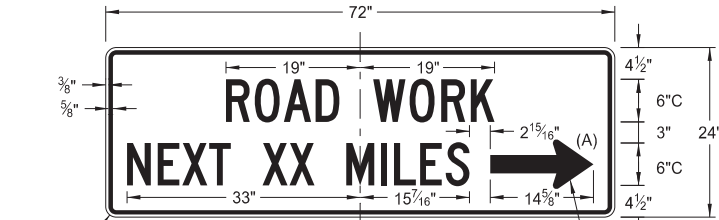

G20-52a-72
Legend: black (non-refl)
Background: orange

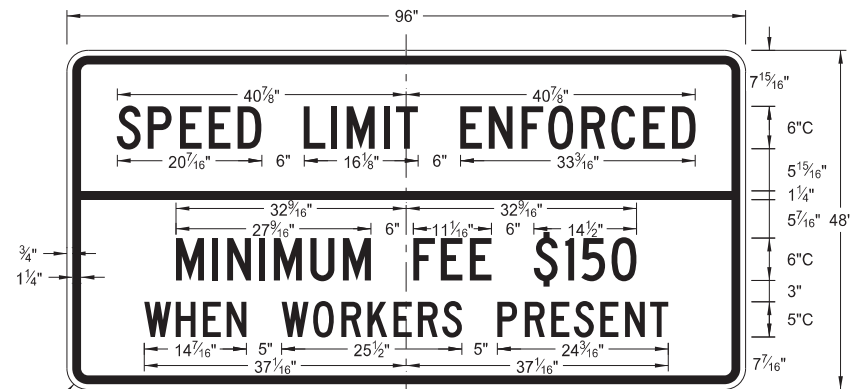

G20-55-96
Legend: black (non-refl)
Background: orange

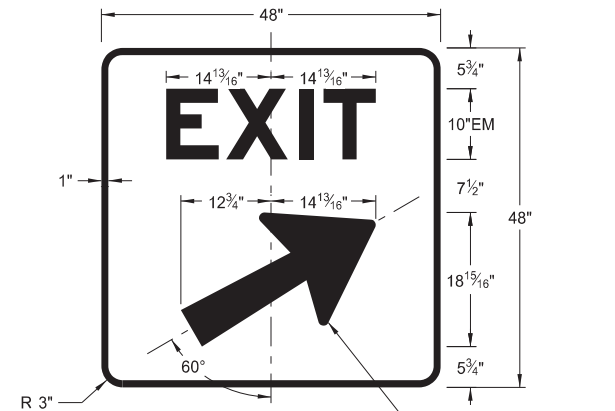

E5-1(L or R)-48
Legend: white
Background: green (orange optional)

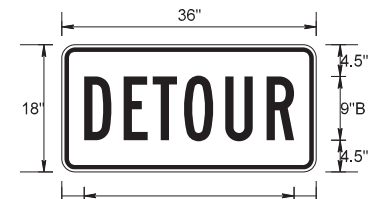

M4-8-36
Legend: black (non-refl)
Background: orange

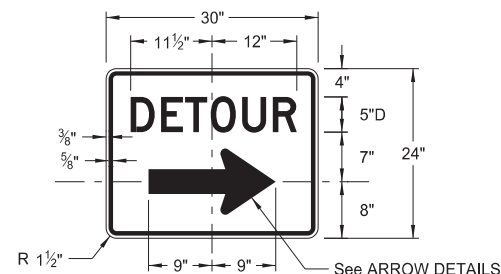

M4-9(L or R)-30 & M4-9-30
Legend: black (non-refl)
Background: orange

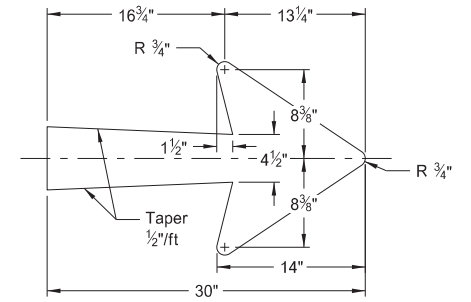

E5-1-48

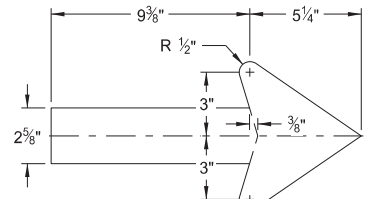

G20-50a-72
G20-52a-72

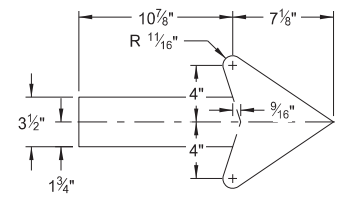

M4-9(L or R)-30
Right or Left

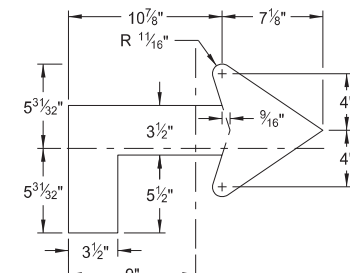

M4-9(L or R)-30
Advanced Right or Left

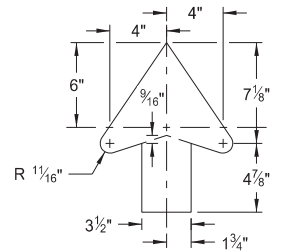

M4-9-30
Straight

ARROW DETAILS

NOTES:

(A) Arrow may be right or left of the legend to indicate construction to the right or left.

NORTH DAKOTA DEPARTMENT OF TRANSPORTATION	
8-13-13	
REVISIONS	
DATE	CHANGE
08-17-17	Added sign & background color
10-03-19	New Design Engineer PE Stamp
08-01-24	Electronic Stamp/Signature
06-30-25	Legislative Changes



CONSTRUCTION SIGN DETAILS
REGULATORY SIGNS

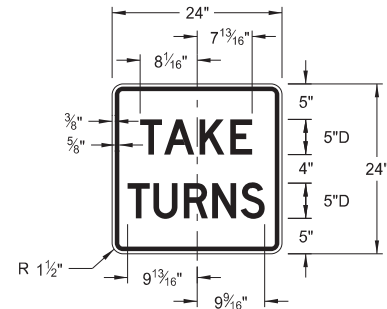

R1-50P-24
Legend: black (non-refl)
Background: white

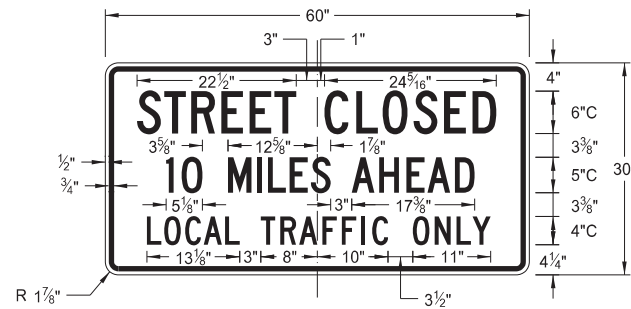

R11-3c-60
Legend: black (non-refl)
Background: white

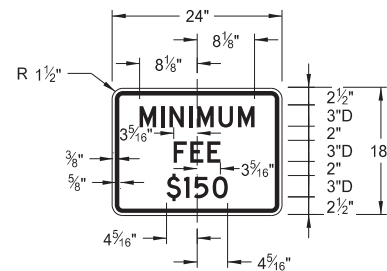

R2-1aP-24
Legend: black (non-refl)
Background: white

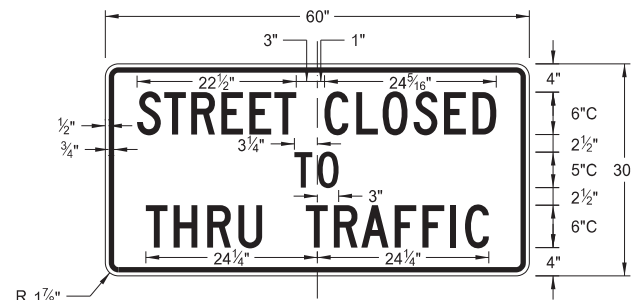

R11-4a-60
Legend: black (non-refl)
Background: white

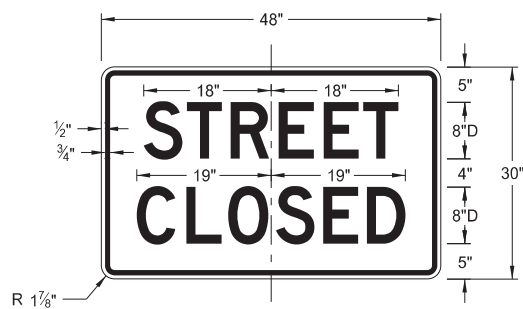

R11-2a-48
Legend: black (non-refl)
Background: white

NORTH DAKOTA DEPARTMENT OF TRANSPORTATION	
8-13-13	
REVISIONS	
DATE	CHANGE
08-17-17	Revised sign number
10-03-19	New Design Engineer PE Stamp
08-01-24	Electronic Stamp/Signature
06-30-25	Legislative Changes



CONSTRUCTION SIGN DETAILS
WARNING SIGNS

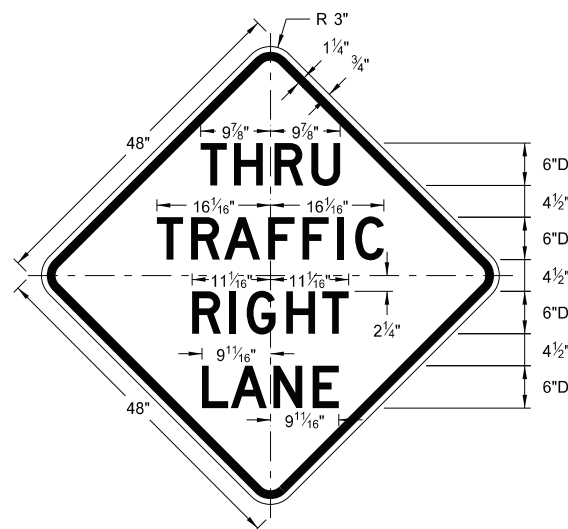

W5-8-48
Legend: black (non-refl)
Background: orange

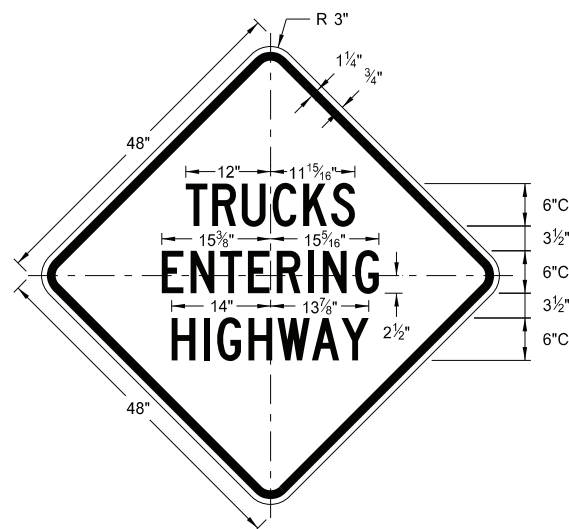

W8-53-48
Legend: black (non-refl)
Background: orange

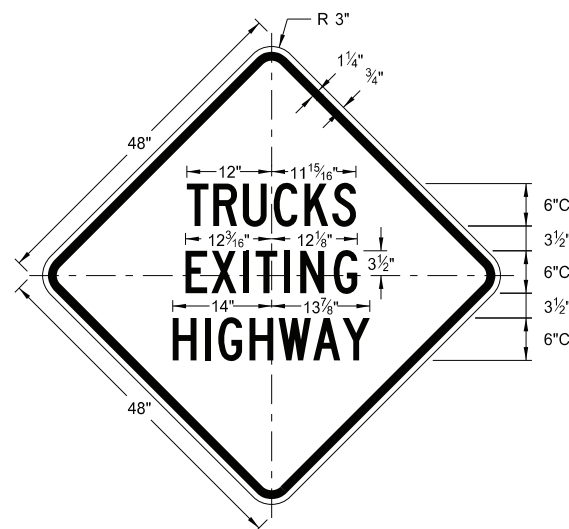

W8-56-48
Legend: black (non-refl)
Background: orange

WORD	LETTER SPACING
AHEAD	Standard
200 FT	Standard
350 FT	Standard
500 FT	Standard
1000 FT	Reduce 40%
1500 FT	Reduce 40%
½ MILE	Reduce 50%
1 MILE	Standard

* DISTANCE MESSAGES

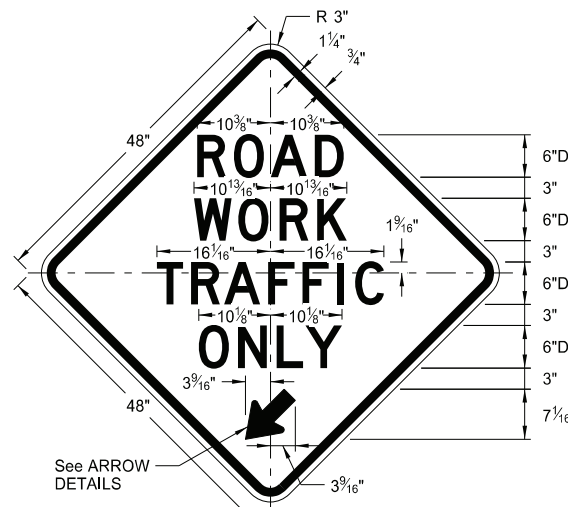

W5-9-48
Legend: black (non-refl)
Background: orange

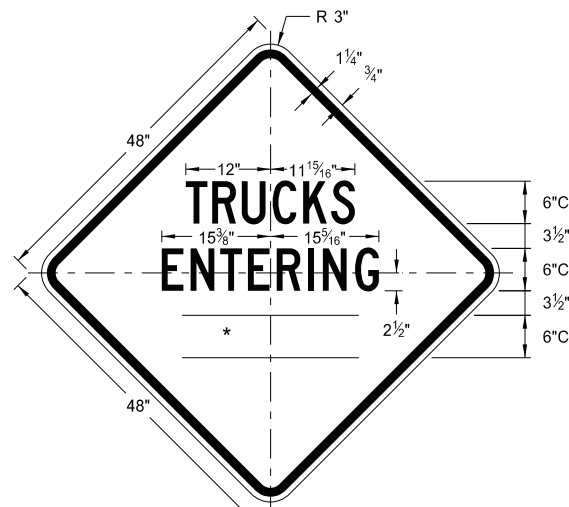

W8-54-48
Legend: black (non-refl)
Background: orange

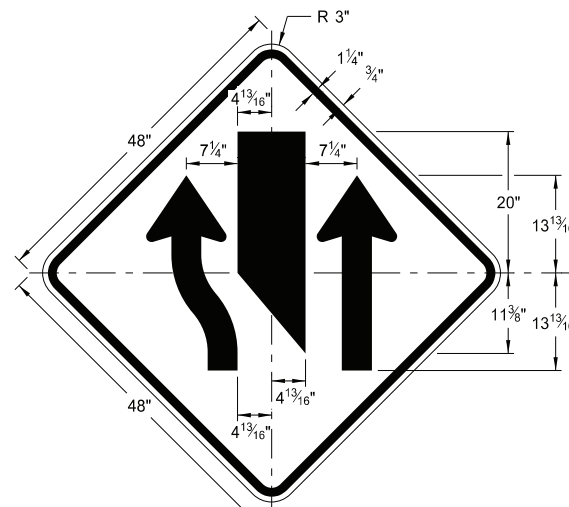

W9-3a-48
Legend: black (non-refl)
Background: orange

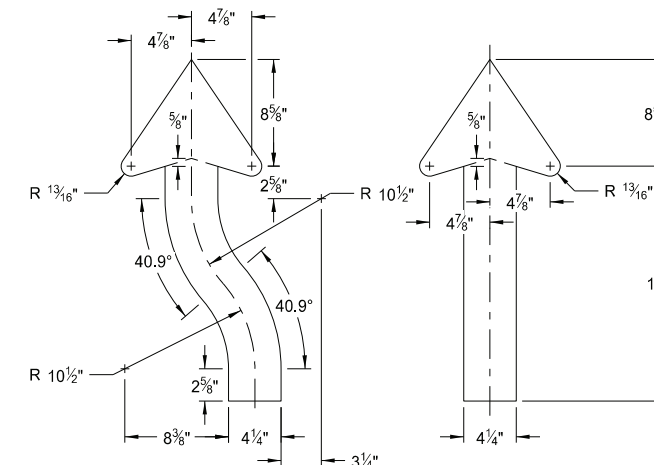
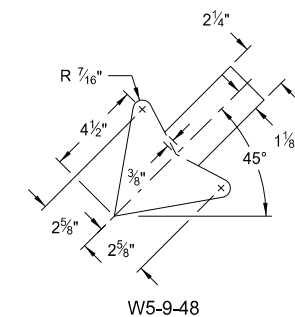

ARROW DETAILS

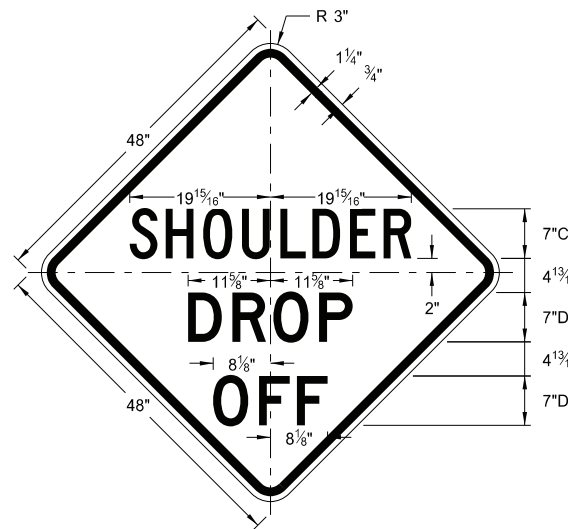

W8-9a-48
Legend: black (non-refl)
Background: orange

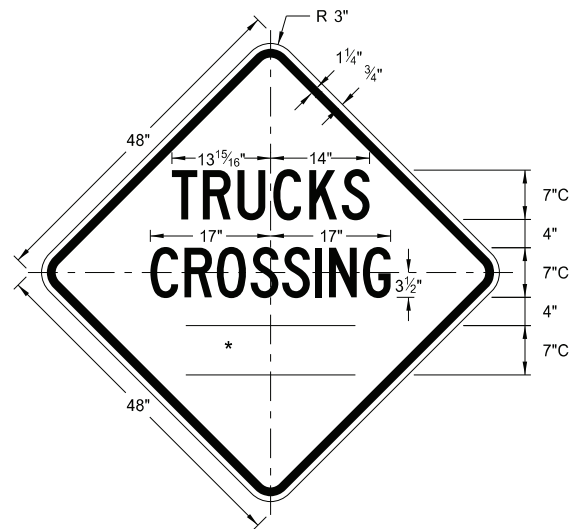

W8-55-48
Legend: black (non-refl)
Background: orange

NORTH DAKOTA DEPARTMENT OF TRANSPORTATION	
8-13-13	
REVISIONS	
DATE	CHANGE
8-17-17	Updated sign number
5-31-18	Revised sign and arrow details
10-03-19	New Design Engineer PE Stamp
8-01-24	Electronic Stamp/Signature



08/01/24

BARRICADE AND CHANNELIZING DEVICE DETAILS

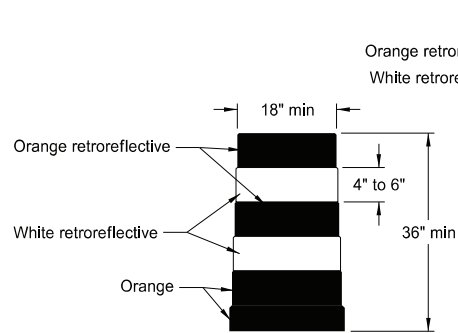

DELINEATOR DRUM

Provide horizontal, circumferential, alternating orange and white retroreflective stripes 4" to 6" wide for drum markings. Use a minimum of two orange and two white stripes with the top stripe being orange for each drum. Do not exceed 3" nonretroreflective spaces between the horizontal orange and white stripes. Avoid placement of stripes on drum ribs or indentations. Use closed top drums that will not allow collection of debris. Do not place ballast on the top of drum.

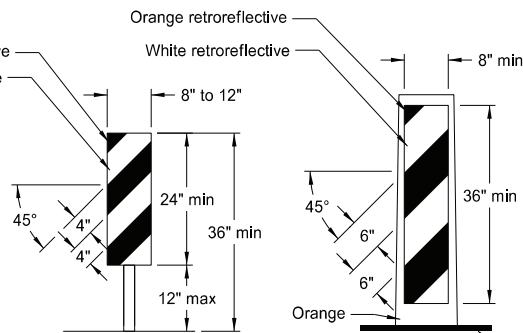

VERTICAL PANEL

Provide alternating orange and white retroreflective stripes, sloping downward in direction vehicular traffic is to pass. Place retroreflective sheeting on both sides of panel with a minimum of 270 square inches of retroreflective area facing vehicular traffic. Where the height of the retroreflective material on the vertical panel is 36 inches or more, use a stripe width of 6 inches.

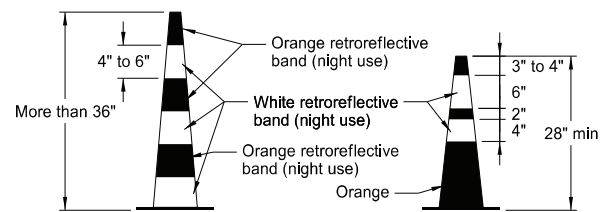

TRAFFIC CONE

Provide retroreflectization of cones more than 36" in height by alternating orange and white retroreflective stripes. Use a minimum of two orange and two white stripes for each cone with the top stripe being orange. Use maximum 3" nonretroreflective space between the orange and white stripes.

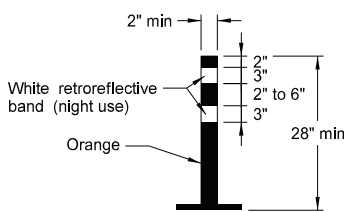

TUBULAR MARKER

Provide retroreflectization of tubular markers more than 42" in height by alternating four 4" to 6" wide orange and white stripes with the top stripe being orange.

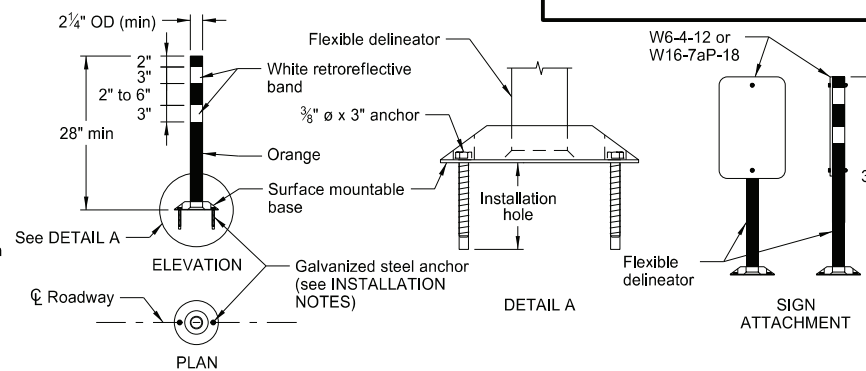

FLEXIBLE DELINEATOR

INSTALLATION NOTES:

1. Drill installation holes to diameter and depth required by manufacturer's specifications.
2. For removal, remove anchors and fill installation hole with an epoxy designed to bond to pavement surface.
3. In lieu of bolted down base, use an 8" x 8" butyl pad or hot melt butyl. Remove butyl as close as possible to pavement surface.

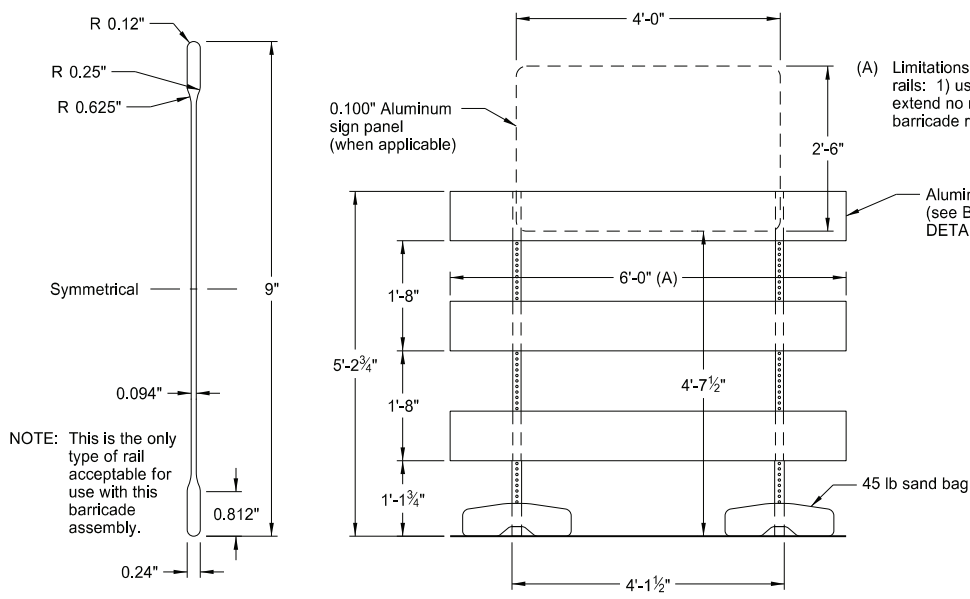

BARRICADE BLADE DETAIL

NOTE: This is the only type of rail acceptable for use with this barricade assembly.

ELEVATION VIEW

BARRICADE ASSEMBLY DETAIL (Aluminum Barricade Rails)

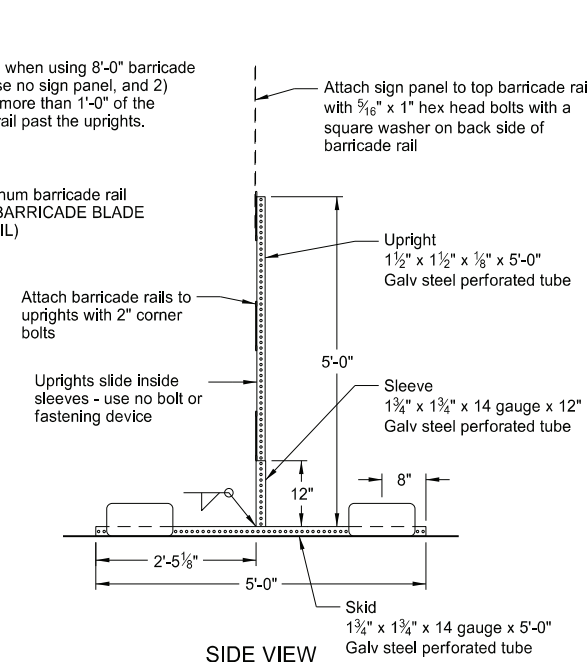

ELEVATION VIEW

BARRICADE ASSEMBLY DETAIL (Wood or Plastic Rails)

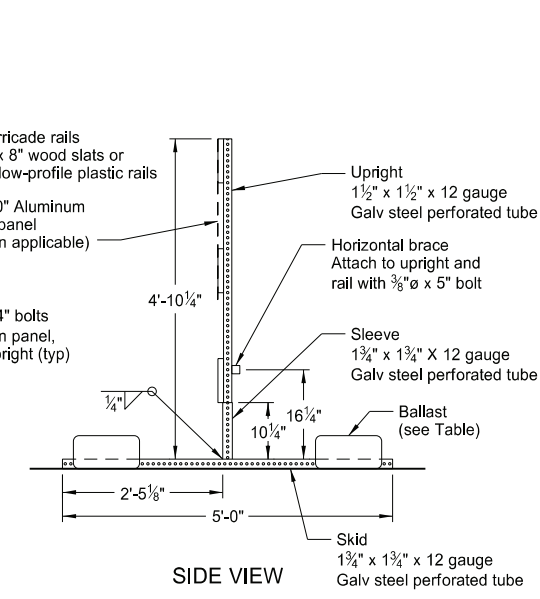

SIDE VIEW

MINIMUM BALLAST (For each side of barricade support)

Without Sign	4 - 25 lb sandbags
With Sign	6 - 25 lb sandbags

Note: Number of sandbags based on a wind speed of 55 MPH. Sandbags assumed to be placed at or near the ends of the skids.

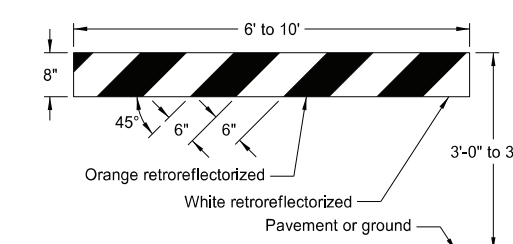

TYPE I BARRICADE

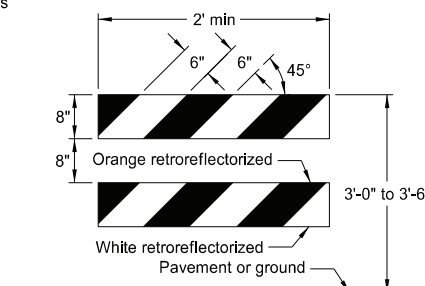

TYPE II BARRICADE

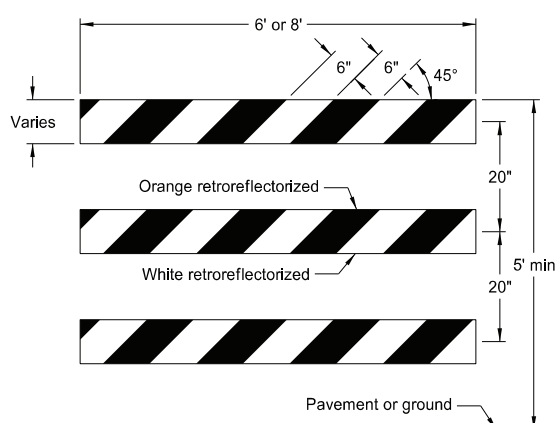

TYPE III BARRICADE

BARRICADE RAIL DETAILS

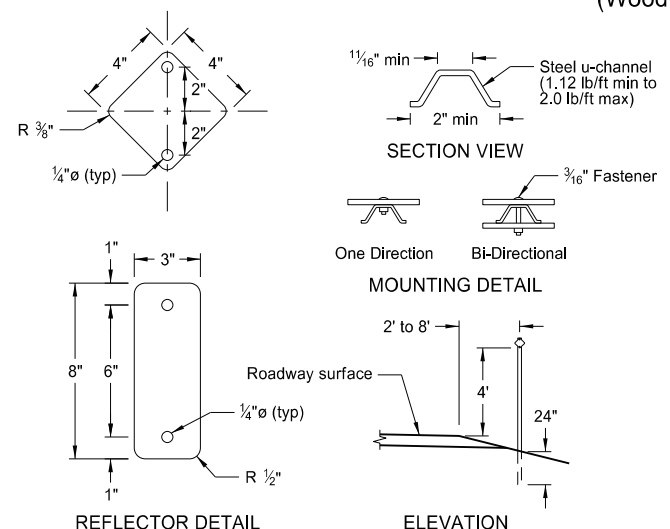

REFLECTOR DETAIL

ELEVATION

DELINEATORS

NORTH DAKOTA DEPARTMENT OF TRANSPORTATION	
10-3-13	
REVISIONS	
DATE	CHANGE
9-27-17	Updated to active voice
11-01-19	Revised details for Flexible Delineator
8-01-24	Electronic Stamp/Signature



08/01/24

CONSTRUCTION SIGN PUNCHING AND MOUNTING DETAILS

Note: In curb sections, place signs a minimum horizontal distance of 2' from face of the curb to near edge of the sign.

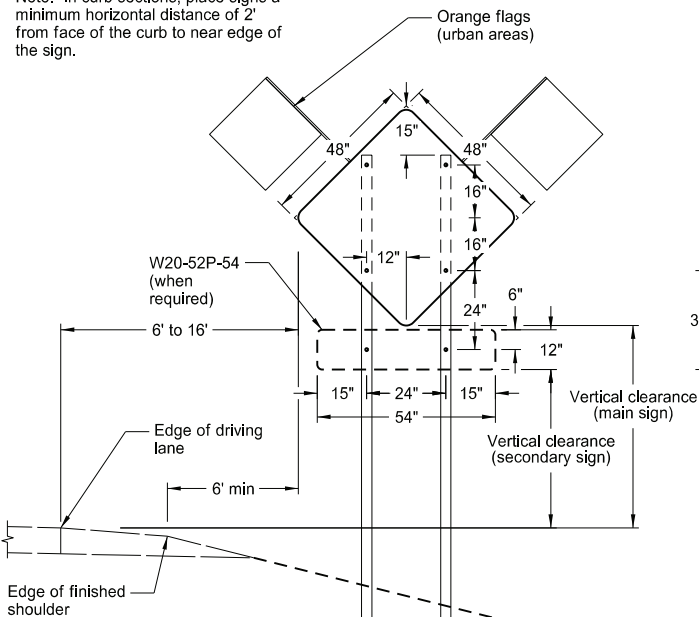

TYPICAL SECTION
(48" x 48" diamond warning sign shown)

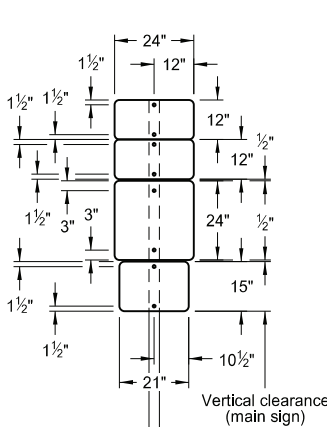

24" x 24" ROUTE MARKER ASSEMBLY

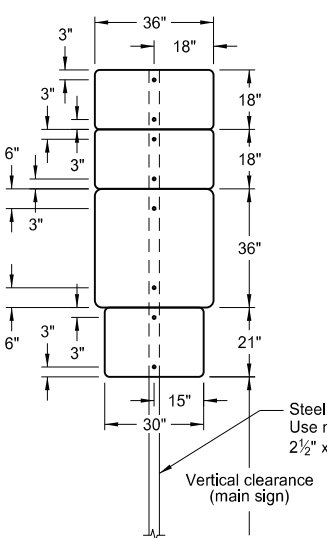

36" x 36" ROUTE MARKER ASSEMBLY

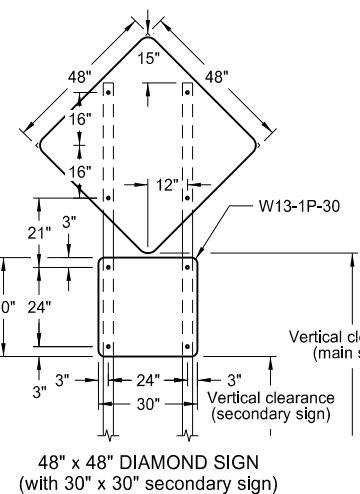

48" x 48" DIAMOND SIGN
(with 30" x 30" secondary sign)

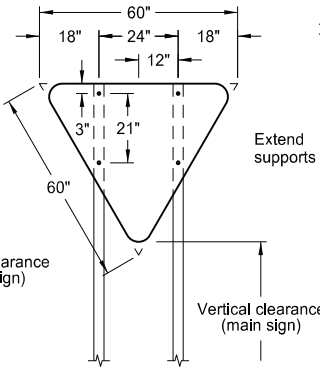

R1-2-60 - YIELD SIGN

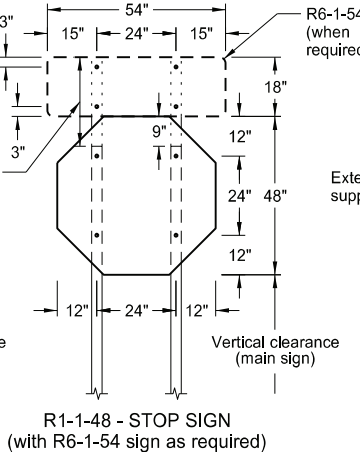

R1-1-48 - STOP SIGN
(with R6-1-54 sign as required)

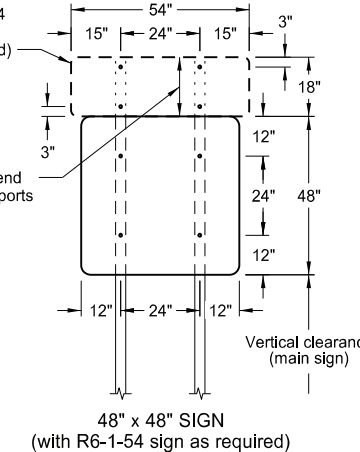

48" x 48" SIGN
(with R6-1-54 sign as required)

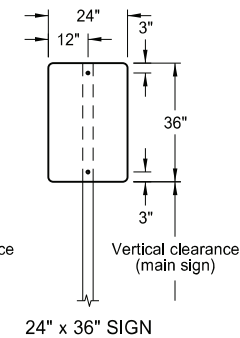

24" x 36" SIGN

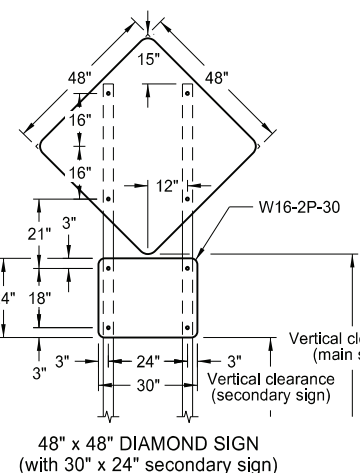

48" x 48" DIAMOND SIGN
(with 30" x 24" secondary sign)

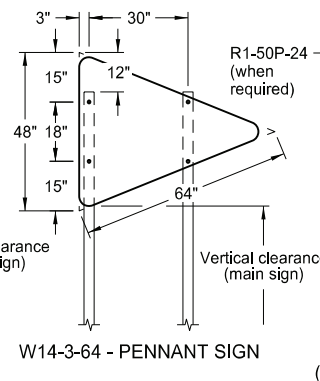

W14-3-64 - PENNANT SIGN

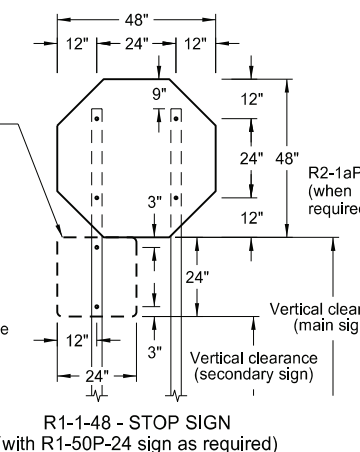

R1-1-48 - STOP SIGN
(with R1-50P-24 sign as required)

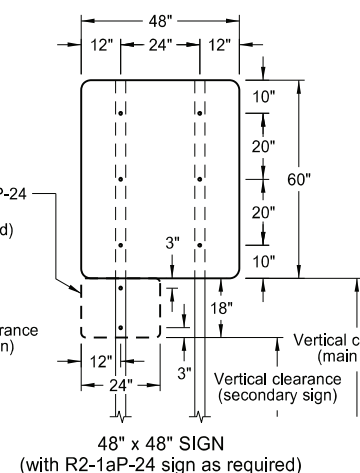

48" x 48" SIGN
(with R2-1aP-24 sign as required)

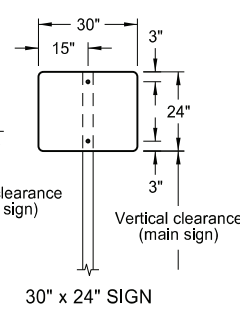

30" x 24" SIGN

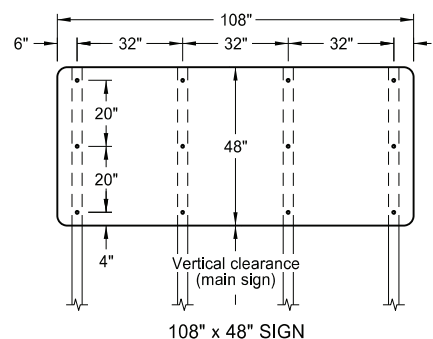

108" x 48" SIGN

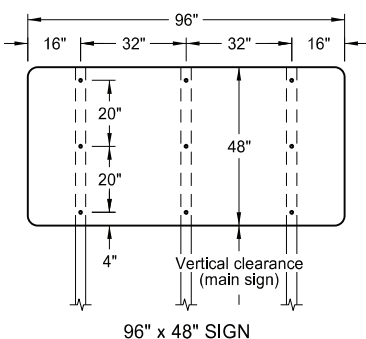

96" x 48" SIGN

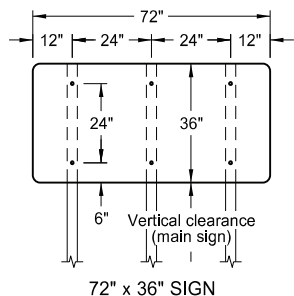

72" x 36" SIGN

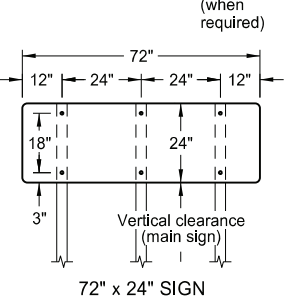

72" x 24" SIGN

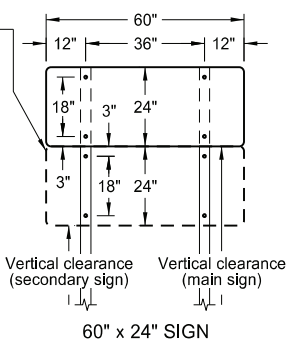

60" x 24" SIGN

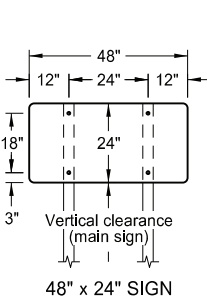

48" x 24" SIGN

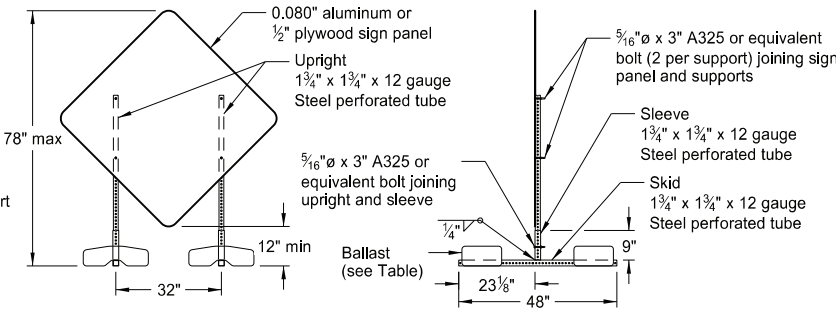

PORTABLE SIGN SUPPORT
LOW-MOUNTING HEIGHT

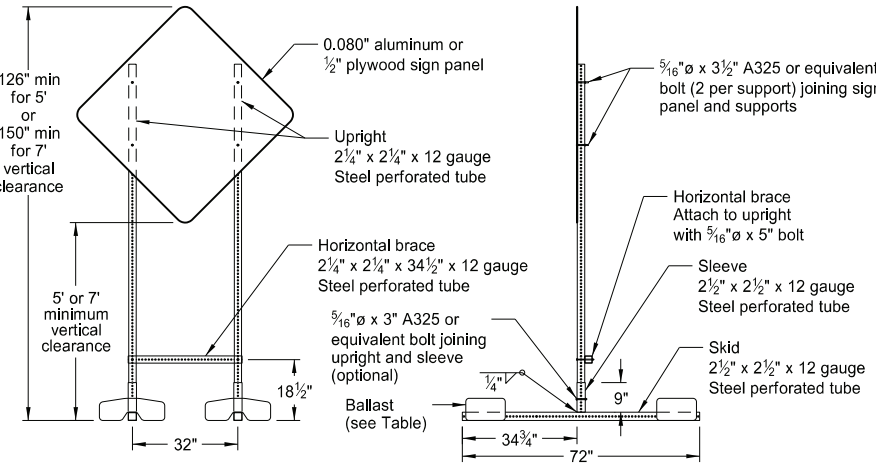

PORTABLE SIGN SUPPORT
HIGH-MOUNTING HEIGHT

NOTES:

- Sign Supports: Galvanize or paint supports. Minimum post sizes are 2.5 lb/ft u-channel or 2" x 2" x 12 gauge steel perforated tube, except where noted. When installing signs on u-channel, minimum post size for assemblies containing a secondary sign is 3.0 lb/ft. Post sizes based on a wind speed of 55 MPH.

Place signs over 50 square feet on 2 1/2" x 2 1/2" perforated tube supports as a minimum.

Do not attach guy wires to sign supports. Attach wind beams behind sign panels when used with u-posts.
- Sign Panels: Provide sign panels made of 0.100" aluminum, 1/2" plywood, or other approved material, except where noted. Punch all holes round for 3/8" bolts.
- Alternate Messages: Install and remove alternate message signs on reflectorized plate (without borders) as required. (i.e. "Left" and "Right" message on lane closure sign)
- Route Marker Auxiliary Signs: Provide route marker auxiliary signs, such as the cardinal direction and directional arrows, with a background and legend that match the route marker they are used with:

Interstate - white legend on blue background
Interstate Business Loop - white legend on green background
US and State - black legend on white background
County - yellow legend on blue background

- Vertical Clearance: Install signs with a vertical clearance of 5'-0" (see TYPICAL SECTION.) In areas where parking or pedestrian movements are likely or the view of the sign may be obstructed, install signs with a vertical clearance of 7'-0" from the top of the curb or from the near edge of the driving lane in absence of a curb.

The vertical clearance to secondary signs is 1'-0" less than the vertical clearance stated above.

Provide a minimum clearance of 7'-0" from the ground at the post for signs with an area exceeding 50 square feet.

- Portable Signs: Provide portable signs that meet the vertical clearance stated above when it is necessary to place signs within the pavement surface.

Use of low-mounting height (minimum 12" vertical clearance) portable signs for 5 days or less, is allowed as long as the view of the sign is not obstructed. Time delays caused by unforeseen circumstances, such as equipment breakdown, rain, subgrade failures, etc., will not accrue towards the 5 day period. Use of R9-8 through R9-11a series, W1-6 through W1-8 series, M4-10, and E5-1 is allowed for longer than 5 days.

Restrict signs mounted on portable sign supports shown in the LOW-MOUNTING HEIGHT and HIGH-MOUNTING HEIGHT details to a maximum surface area of 16 square feet.

MINIMUM BALLAST
(For each side of sign support base)

Sign Panel Mounting Height (ft)	Number of 25 lb sandbags for 4' x 4' sign panel
1'	6
5'	8
7'	10

Note: The number of sandbags are based on a wind speed of 55 MPH. Place sandbags at or near the ends of sklds.

NORTH DAKOTA DEPARTMENT OF TRANSPORTATION	
10-4-13	
REVISIONS	
DATE	CHANGE
11-14-13	Revised Note 6
9-27-17	Updated to active voice
11-01-19	Revised 60"x24" sign detail
8-01-24	Electronic Stamp/Signature



08/01/24

SIGN LAYOUT FOR ONE LANE CLOSURE TWO LANE ROADWAY

D-704-17

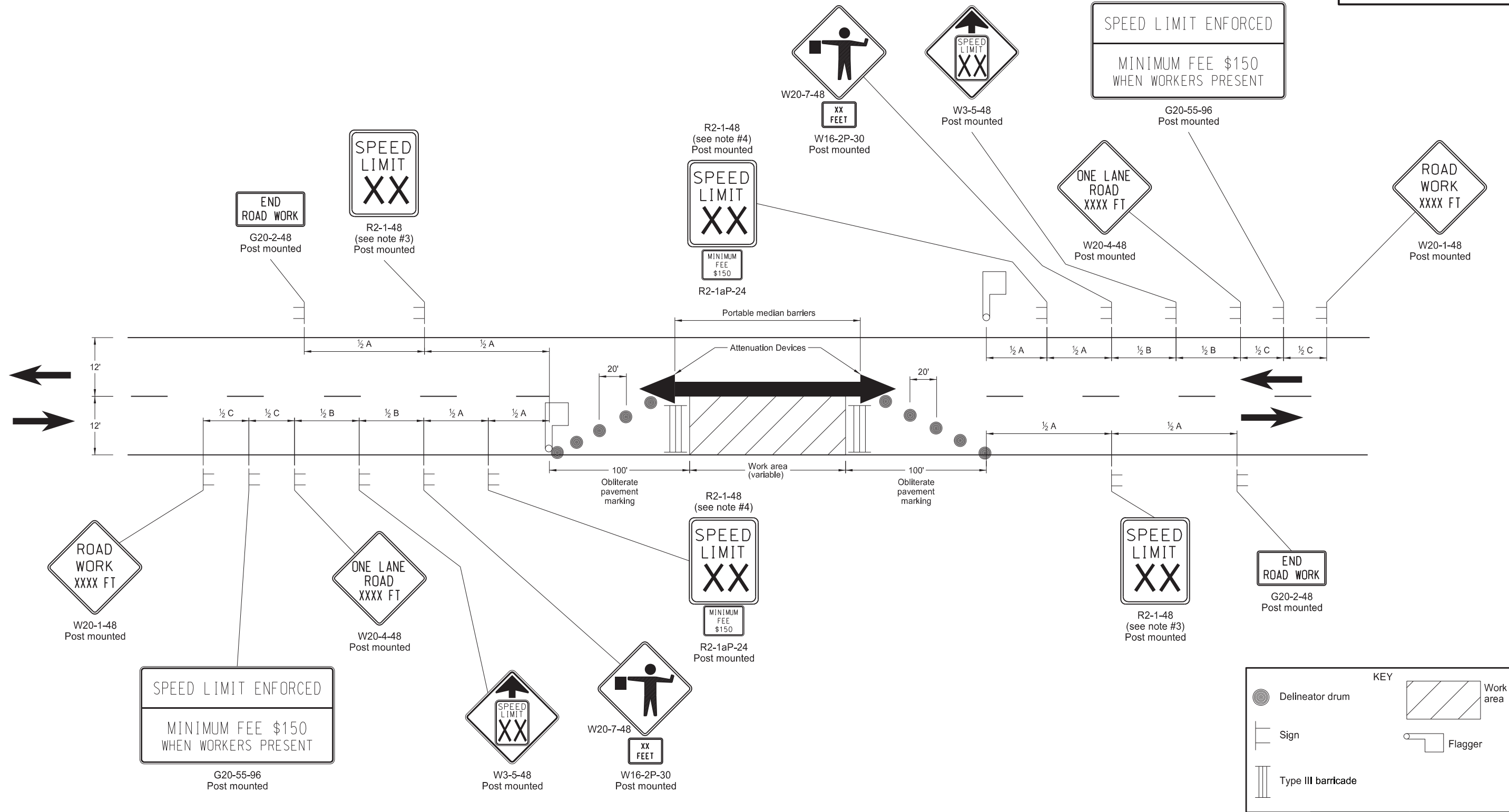

KEY

- Delineator drum
- Sign
- Type III barricade
- Work area
- Flagger

Notes:

- Place barricades on moveable assemblies and signs on portable assemblies when located on roadway.
- Remove existing striping as required. Use back to back delineators when inslope is 4:1 or flatter and roadway alignment is visible to approaching vehicles. Place back to back vertical panels when roadways have steep slopes and alignment is not visible to approaching traffic.
- Re-establish speed limit. Determine exact speed limit in the field, dependent on location and conditions.
- Determine the reduced speed limit based on the in-place speed limit before construction. Where speed reductions exceed 30 MPH, install a second speed limit sign with the desired speed reduction (not to exceed 30 MPH.) Place the second speed limit sign at 1/2 B.
- Install flags on warning signs in urban areas when signs are not portable. Mount 24 inch square flags perpendicular to the edges of the sign, and at such a distance above the edge that the flag does not touch the sign when limp.
- As an option, use portable sign supports in lieu of post mounted signs in accordance with NDDOT Standard Drawing D-704-14.
- Cover existing speed limit signs within a reduced speed zone.
- Sign G20-55-96 is not required if this layout is part of other traffic control that contains this sign, or if work is less than 15 days.
- Recommend using 40 mph speed limit in vicinity of workers, unless location and conditions dictate otherwise.

ADVANCE WARNING SIGN SPACING			
Road Type	Distance Between Signs Min. (ft)		
	A	B	C
Urban - Low Speed (30 mph or less)	150	150	150
Urban - Low Speed (over 30 to 40 mph)	280	280	280
Urban - High Speed (over 40 mph to 50 mph)	360	360	360
Rural - High Speed (over 50 mph to 65 mph)	720	720	720
Urban Expressway and Freeway (55 mph to 60 mph)	850	1350	2200
Rural Expressway and Freeway (70 mph to 80 mph)	1000	1500	2640
Interstate/4-Lane Divided (Maintenance and Surveying)	750	1000	1500

NORTH DAKOTA DEPARTMENT OF TRANSPORTATION	
9-27-13	
REVISIONS	
DATE	CHANGE
08-17-17	Note update & sign numbers
11-01-19	Removed signs & revised note
12-08-21	Switched order of Road Work XXXX and Spd Limit Enforced & added Dollars At Work
11-29-22	Removed Dollars At Work
08-21-24	Pvmt Mkg Width & Med Barter
06-30-25	Legislative Changes



DETOUR AND ROADWAY DIVERSION SIGN LAYOUTS

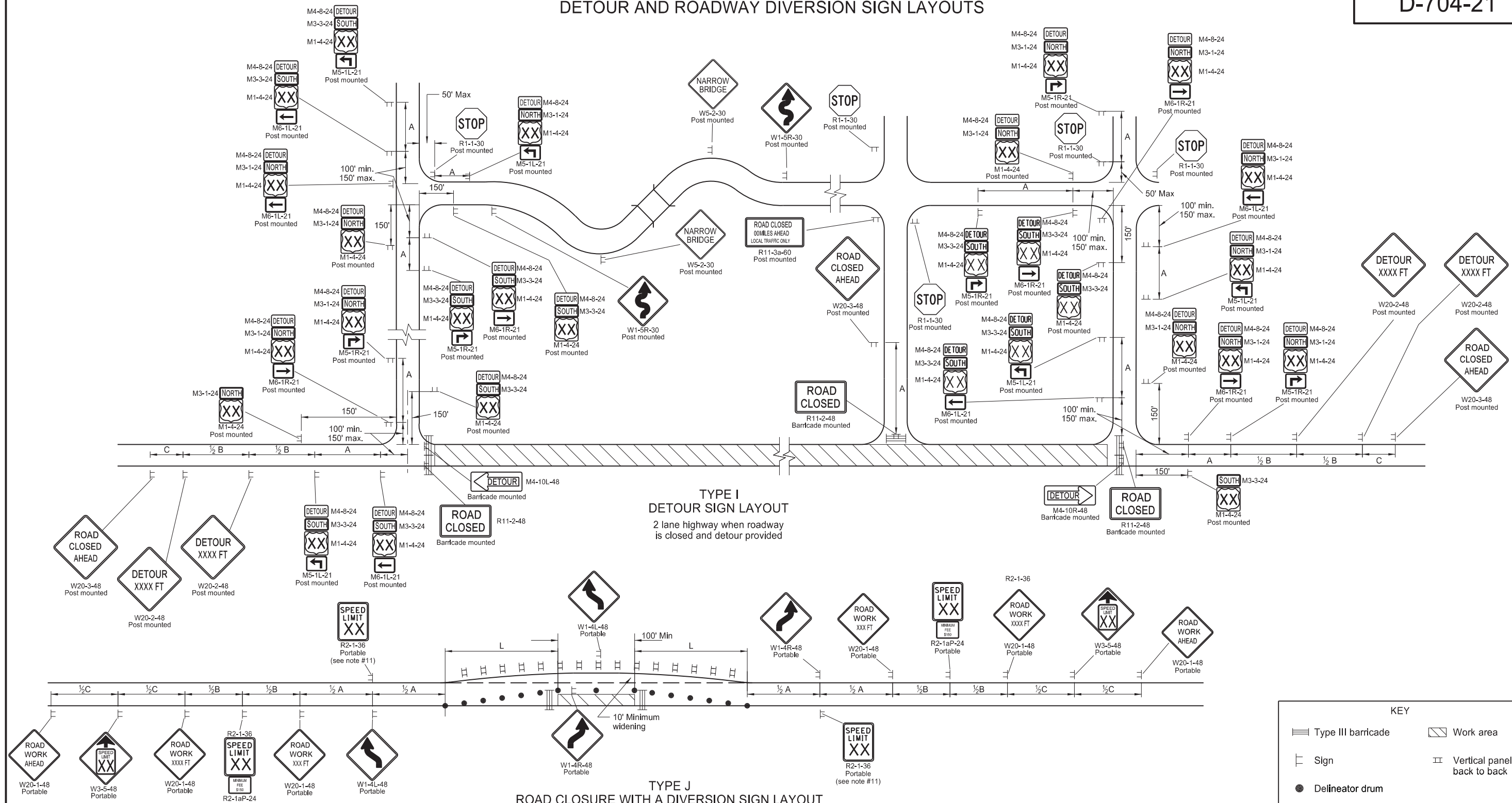

TYPE I
DETOUR SIGN LAYOUT
2 lane highway when roadway is closed and detour provided

TYPE J
ROAD CLOSURE WITH A DIVERSION SIGN LAYOUT
2 lane highway with widened section, traffic maintained in both directions.

Use layout when work is less than 5 days or is within a project.

- Notes:
- Variables
S= Numerical value of speed limit or 85th percentile. W= The width of taper.
L= Minimum length of taper, or $S \times W$ for freeways, expressways, and all other roads with speeds of 45 mph or greater, or $W \times S^2 / 60$ for urban, residential, and other streets with speeds of 40 mph or less.
 - Place barricades on moveable assemblies and signs on portable assemblies when on roadway.
 - Space delineator drums and vertical panels at dimension "S" for tapering traffic. Space delineator drums, tubular markers and vertical panels at 2 times "S" for tangents.
 - Determine the reduced speed limit based on the in place speed limit before construction. Where speed limits exceed 30 MPH, install a second speed limit sign with the desired speed reduction (not to exceed 30 mph.) Place the second speed limit sign at $\frac{1}{2} B$.
 - Install flags on warning signs in urban areas when signs are not portable. Mount 24 inches square flags perpendicular to the edges of the sign, and at such a distance above the edge that the flag does not touch the sign when limp.
 - Cover existing speed limit signs within a reduced speed limit zone.
 - Covered (when approved by engineer) or obliterated pavement marking measured as Obliteration of Pavement Marking.
 - As an option, use portable sign supports in lieu of post mounted signs in accordance with NDDOT Standard Drawing D-704-14.
 - If the tangent between tapers is less than 600', as an option, use sign W24-1-48 in place of double reverse curve signs.
 - Recommend using 40 mph speed limit in vicinity of workers, unless location and conditions dictate otherwise.
 - Re-establish speed limit. Determine exact speed limit in the field, dependent on location and conditions.

KEY

- Type III barricade
- Work area
- Sign
- Vertical panels back to back
- Delineator drum

Road Type	Distance Between Signs Min. (ft)		
	A	B	C
Urban - Low Speed (30 mph or less)	150	150	150
Urban - Low Speed (over 30 to 40 mph)	280	280	280
Urban - High Speed (over 40 mph to 50 mph)	360	360	360
Rural - High Speed (over 50 mph to 65 mph)	720	720	720
Urban Expressway and Freeway (55 mph to 60 mph)	850	1350	2200
Rural Expressway and Freeway (70 mph to 80 mph)	1000	1500	2640
Interstate/4-Lane Divided (Maintenance and Surveying)	750	1000	1500

NORTH DAKOTA DEPARTMENT OF TRANSPORTATION	
9-27-13	
REVISIONS	
DATE	CHANGE
08-17-17	Updated notes & added spd limit
11-01-19	Revised sign #s and note 8
12-08-21	Added Dollars At Work sign
11-29-22	Removed Dollars At Work
06-30-25	Legislative Changes



LANE CLOSURES ON URBAN STREETS LAYOUTS

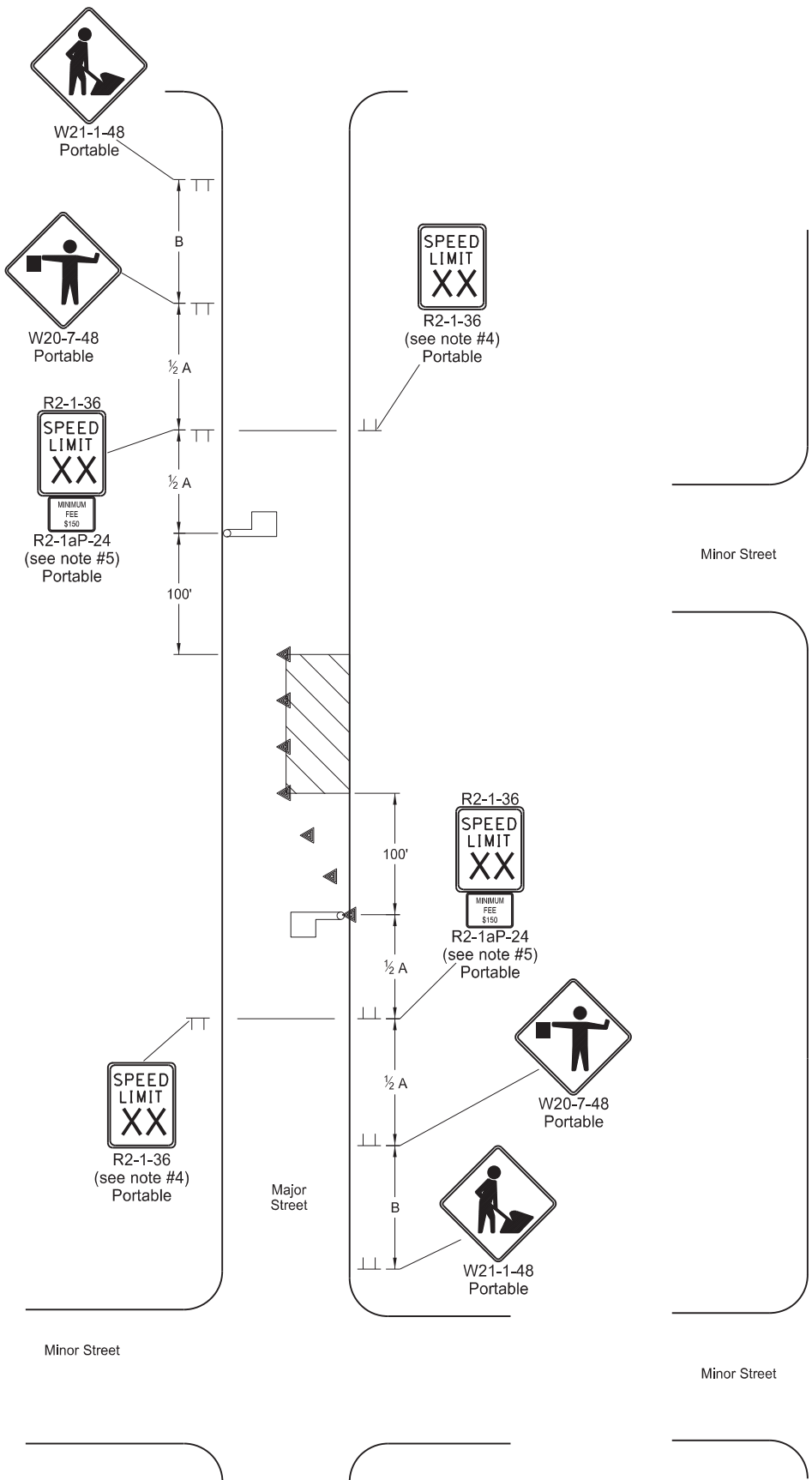

TYPE V
LANE CLOSURE ON URBAN STREET

Portion of roadway closed to traffic only during daylight hours (mid block location).

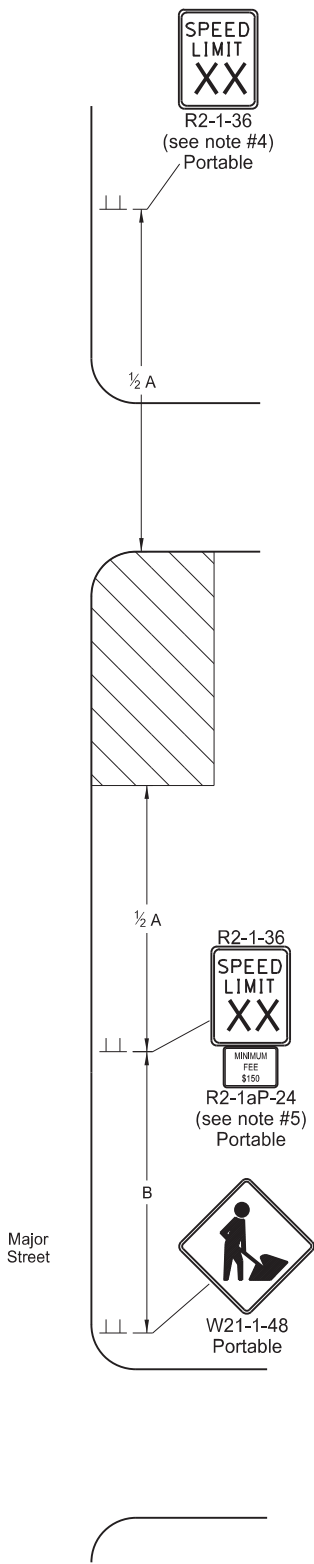

TYPE W
WORK BEYOND CURB ON URBAN STREET

Work area outside driving lane and no closure necessary.

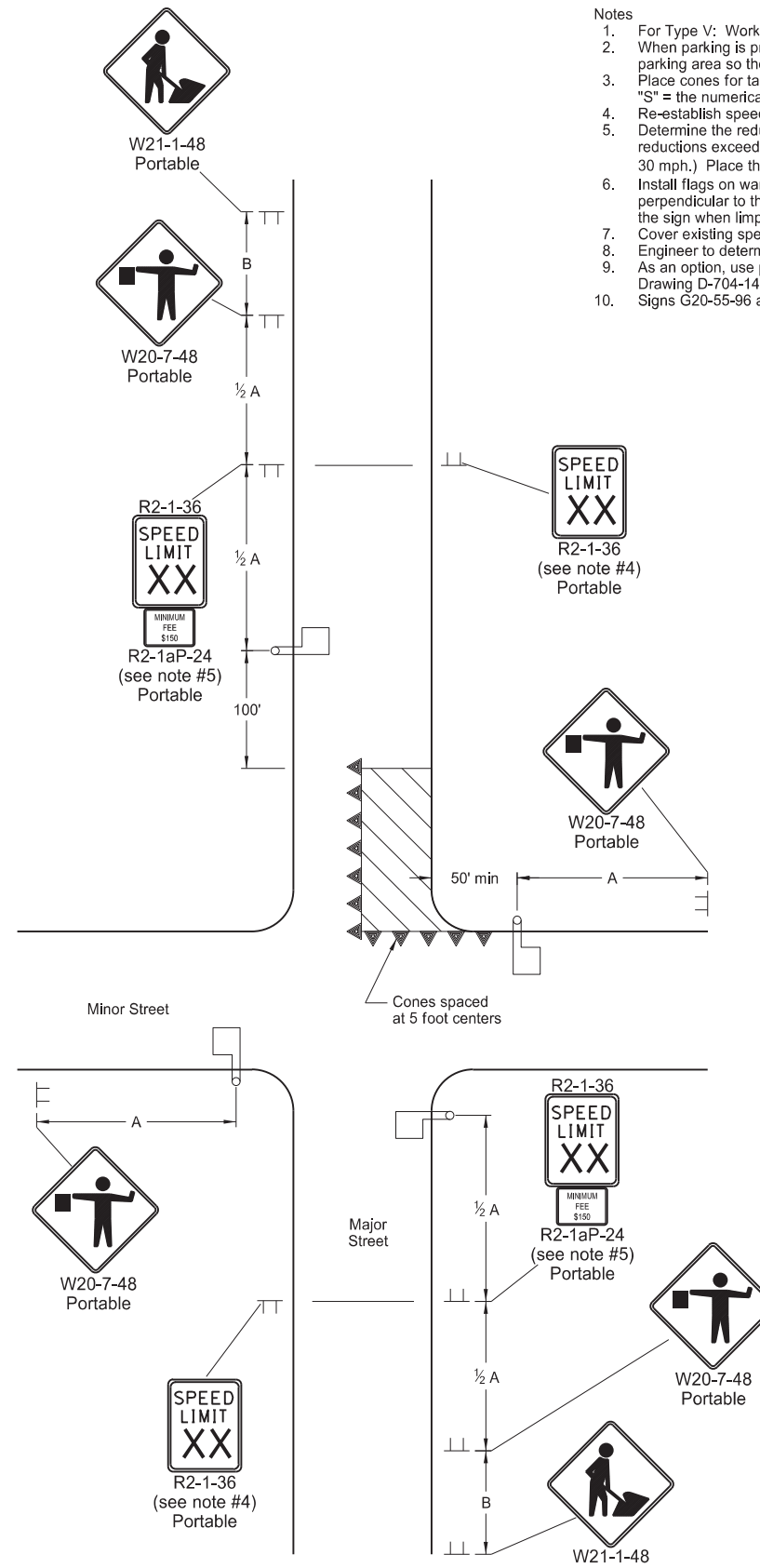

TYPE X
LANE CLOSURE NEAR INTERSECTION ON URBAN STREET

Portion of roadway closed to traffic only during daylight hours (end block location).

- Notes
- For Type V: Work on one side of roadway at a time so as not to block off more than one lane of traffic.
 - When parking is present, place signs so they are entirely visible above parked vehicles or at the edge of the parking area so they are visible to oncoming traffic. Place signs on portable mounts when located on roadway.
 - Place cones for tapering traffic at 3 equal spaces and cones for tangents at dimension "S". "S" = the numerical value of speed limit.
 - Re-establish speed limit. Determine exact speed limit in the field, dependent on location and conditions.
 - Determine the reduced speed limit based on the in-place speed limit before construction. Where speed reductions exceed 30 mph, install a second speed limit sign with the desired speed reduction (not to exceed 30 mph.) Place the second speed limit sign at 1/2 B.
 - Install flags on warning signs in urban areas when signs are not portable. Mount 24 inches square flags perpendicular to the edges of the sign, and at such a distance above the edge that the flag does not touch the sign when limp.
 - Cover existing speed limit signs within reduced speed zones.
 - Engineer to determine safe speed, when necessary.
 - As an option, use portable sign supports in lieu of post mounted signs in accordance with NDDOT Standard Drawing D-704-14.
 - Signs G20-55-96 and R2-1aP-24 are not required for urban projects.

Road Type	ADVANCE WARNING SIGN SPACING		
	Distance Between Signs Min. (ft)		
	A	B	C
Urban - Low Speed (30 mph or less)	150	150	150
Urban - Low Speed (over 30 to 40 mph)	280	280	280
Urban - High Speed (over 40 mph to 50 mph)	360	360	360
Rural - High Speed (over 50 mph to 65 mph)	720	720	720
Urban Expressway and Freeway (55 mph to 60 mph)	850	1350	2200
Rural Expressway and Freeway (70 mph to 80 mph)	1000	1500	2640
Interstate/4-Lane Divided (Maintenance and Surveying)	750	1000	1500

KEY	
	Sign
	Work area
	Cones
	Flagger

NORTH DAKOTA DEPARTMENT OF TRANSPORTATION	
9-27-13	
REVISIONS	
DATE	CHANGE
08-17-17	Updated notes & removed signs
11-01-19	Revised note & added Min Fee sign
08-01-24	Electronic Stamp/Signature
06-30-25	Legislative Changes



MISCELLANEOUS SIGN LAYOUTS

D-704-26

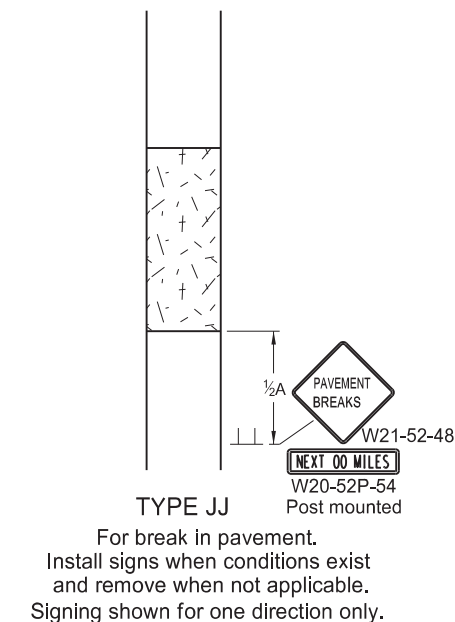
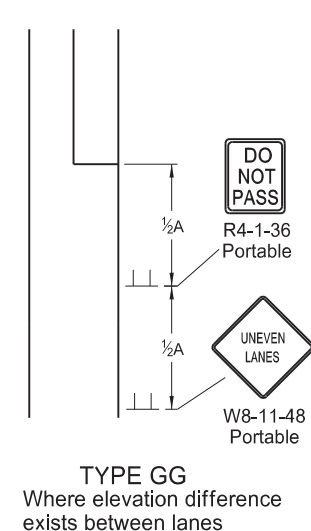
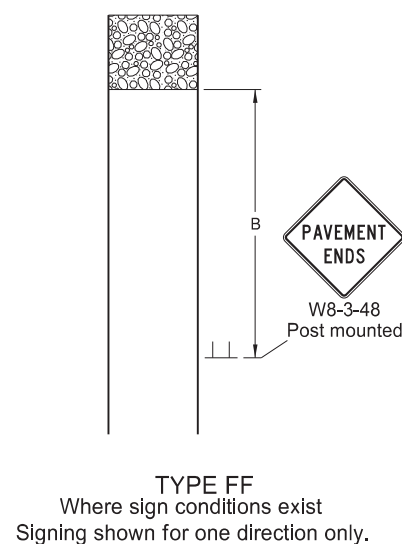
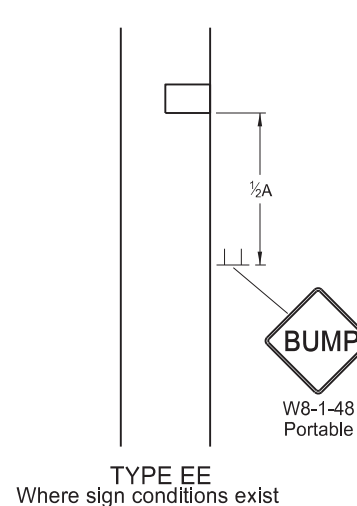
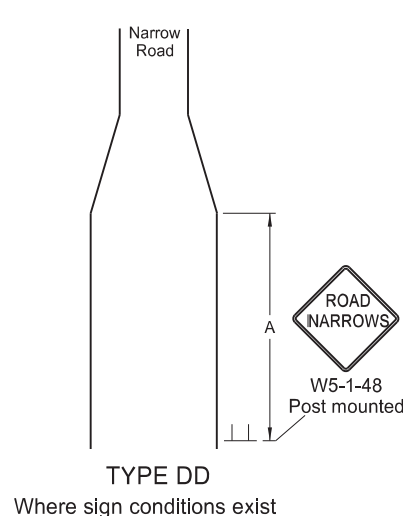
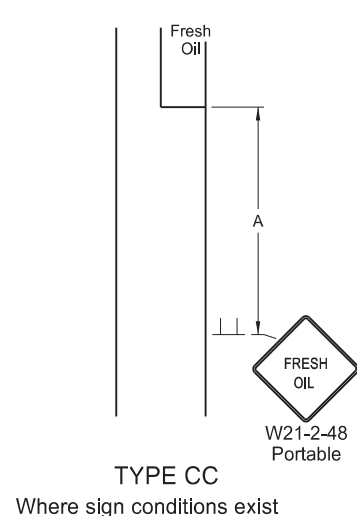
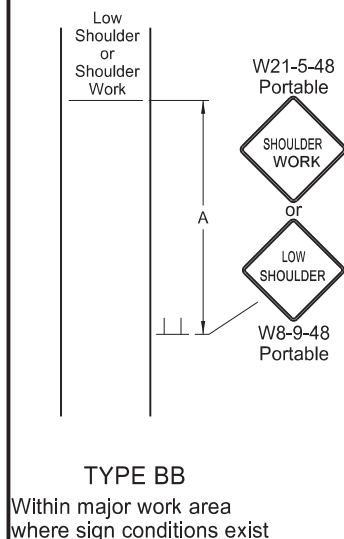
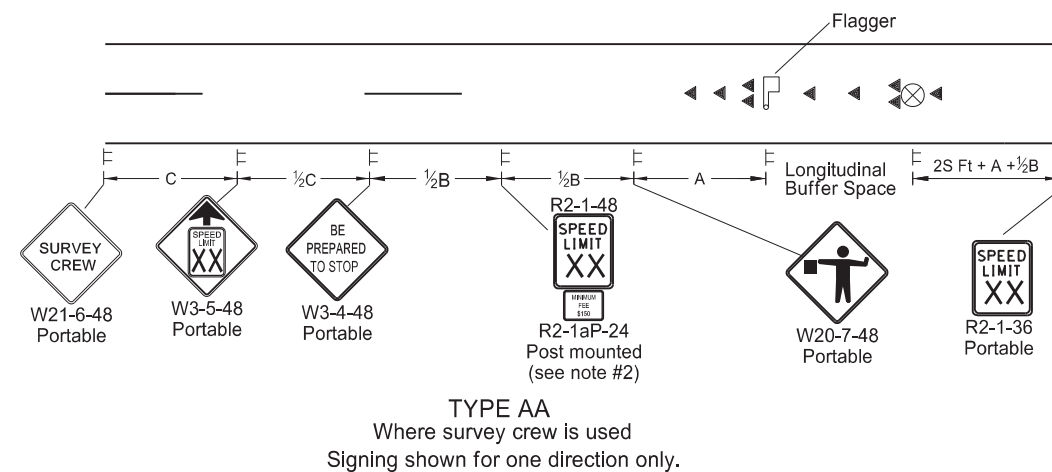
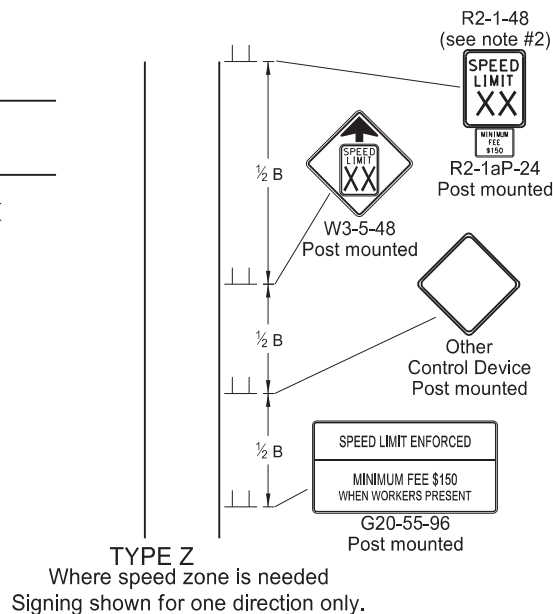
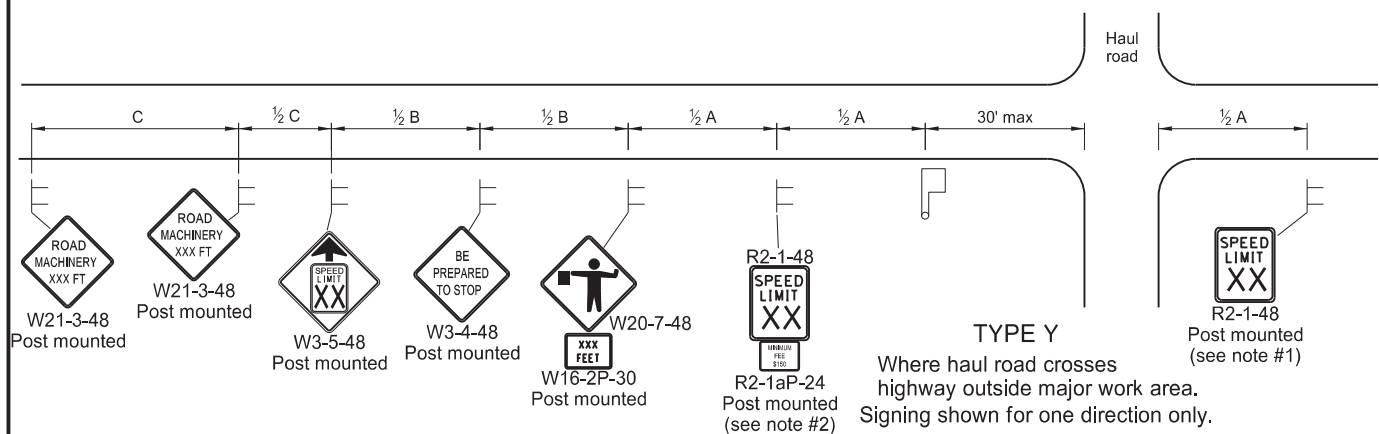

KEY

- Flagger
- Sign
- Cones
- Survey Equipment

S = Numerical value of speed limit or 85th percentile.

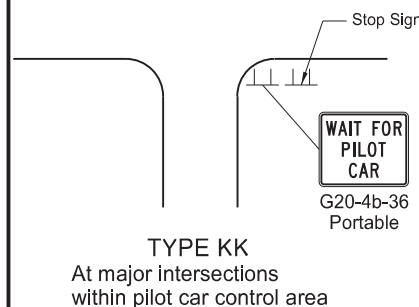

- Notes**
- Re-establish speed limit. Determine exact speed limit in the field, dependent on location and conditions. Determine reduced speed limit based on in-place speed limit before construction. Where speed reductions exceed 30 mph, install a second speed limit sign with the desired speed reduction (not to exceed 30 mph.)
 - Place the second speed limit sign at 1/2B.
 - Install flags on warning signs in urban areas when signs are not portable. Mount 24 inch square flags perpendicular to the edges of the sign, and at such a distance above the edge that the flag does not touch the sign when limp.
 - Cover existing speed limit signs within reduced speed zones.
 - As an option, use portable sign supports in lieu of post mounted signs in accordance with NDDOT Standard Drawing D-704-14.
 - Sign G20-55-96 is not required if this standard is part of other traffic control layouts, or work is less than 15 days.
 - When pilot car operation is used, place sign G20-4b-36 "Wait For Pilot Car" at major intersections within pilot car control area.
 - Recommend 40 mph speed limit in vicinity of workers, unless location and conditions dictate otherwise.
 - Layouts shown for one direction only.

ADVANCE WARNING SIGN SPACING			
Road Type	Distance Between Signs Min. (ft)		
	A	B	C
Urban - Low Speed (30 mph or less)	150	150	150
Urban - Low Speed (over 30 to 40 mph)	280	280	280
Urban - High Speed (over 40 mph to 50 mph)	360	360	360
Rural - High Speed (over 50 mph to 65 mph)	720	720	720
Urban Expressway and Freeway (65 mph to 60 mph)	850	1350	2200
Rural Expressway and Freeway (70 mph to 80 mph)	1000	1500	2640
Interstate/4-Lane Divided (Maintenance and Surveying)	750	1000	1500

Longitudinal Buffer Space	
*Speed (mph)	Length Min (feet)
20	115
25	155
30	200
35	250
40	305
45	360
50	425
55	495
60	570
65	645
70	730
75	820
80	910

* Posted speed, off-peak 85th percentile speed prior to work starting, or the anticipated operating speed in mph.

NORTH DAKOTA DEPARTMENT OF TRANSPORTATION	
9-27-13	
REVISIONS	
DATE	CHANGE
08-17-17	Added speed limit signs. Updated notes & sign numbers
11-01-19	Revised note 5 & sign numbers
02-23-23	Revised distance & removed signs
06-30-25	Legislative Changes



SIGN LAYOUT FOR ONE LANE CLOSED DIVIDED HIGHWAY MOVING OPERATION

D-704-32

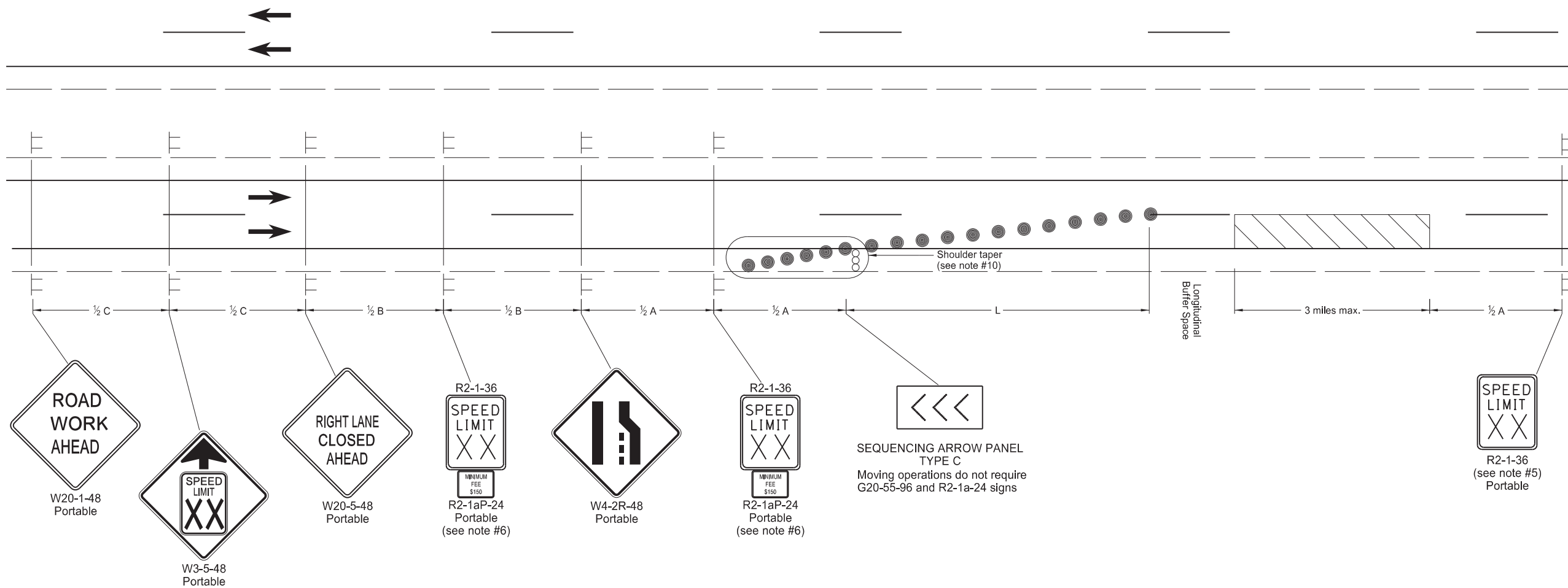

- Notes**
- Provide an additional sequencing arrow panel in the closed lane, near the work area, if the moving operation is not visible to the motorist from the end of the taper.
 - Variables
 S = Numerical value of speed limit or 85th percentile.
 W = The width of the taper.
 L = Minimum length of taper, $S \times W$ for freeways, expressways, and all other roads with speeds of 45 mph or greater, or $W \times S^2 / 60$ for urban, residential, and other streets with speeds of 40 mph or less.
 - Space delineator drums for tapering traffic at dimension "S".
 - Sequencing Arrow Panels
 Panels should normally be placed at the beginning of the taper. Where shoulder width does not provide sufficient room, the panel should be moved closer to the work area so that it can be placed on the roadway surface.
 Type A shall be used on roadways with slow moving traffic speeds and low volume (25 mph & 750 ADT or less).
 Type B shall be used on roadways with moderate traffic speeds and volumes (40 mph and 5000 ADT or less).
 Type C shall be used on roadways with high traffic speeds and volumes (over 40 mph and 5000 ADT).
 - Re-establish speed limit. Determine the exact speed limit in the field, dependent on location and conditions.
 - Determine the reduced speed limit the in-place speed limit before construction. Where speed reductions exceed 30 mph, install a second speed limit sign with the desired speed reduction (not to exceed 30 mph.) Place the second speed limit sign at 1/2 B.
 - Install flags on warning signs in urban areas when signs are not portable, Mount 24 inch square flags perpendicular to the edges of the sign, and at such a distance above the edge that the flag does not touch the sign when limp.
 - Cover existing speed limit signs within a reduced speed zone.
 - As an option, use portable sign supports in lieu of post mounted signs in accordance with NDDOT Standard Drawing D-704-14.
 - Provide shoulder taper when shoulder is 8' or wider.
 - Recommend using 40 mph speed limit in vicinity of workers, unless location and conditions dictate otherwise.

SEQUENCING ARROW PANEL
TYPE C
Moving operations do not require G20-55-96 and R2-1a-24 signs

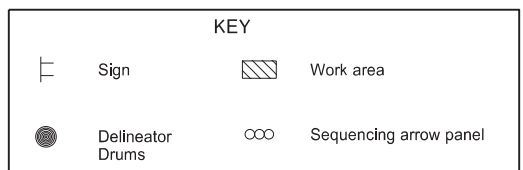

Longitudinal Buffer Space	
*Speed (mph)	Length Min (feet)
20	115
25	155
30	200
35	250
40	305
45	360
50	425
55	495
60	570
65	645
70	730
75	820
80	910

* Posted speed, off-peak 85th percentile speed prior to work starting, or anticipated operating speed in mph.

Road Type	Distance Between Signs Min. (ft)		
	A	B	C
Urban - Low Speed (30 mph or less)	150	150	150
Urban - Low Speed (over 30 to 40 mph)	280	280	280
Urban - High Speed (over 40 mph to 50 mph)	360	360	360
Rural - High Speed (over 50 mph to 65 mph)	720	720	720
Urban Expressway and Freeway (55 mph to 60 mph)	850	1350	2200
Rural Expressway and Freeway (70 mph to 80 mph)	1000	1500	2640
Interstate/4-Lane Divided (Maintenance and Surveying)	750	1000	1500

NORTH DAKOTA DEPARTMENT OF TRANSPORTATION	
9-27-13	
REVISIONS	
DATE	CHANGE
06-24-14	Revised Note 9
08-17-17	Updated notes & sign numbers
11-01-19	Added sign, revised note & sign #
08-02-24	Electronic Stamp/Signature
06-30-25	Legislative Changes



PORTABLE SIGN SUPPORT ASSEMBLY

D-704-50

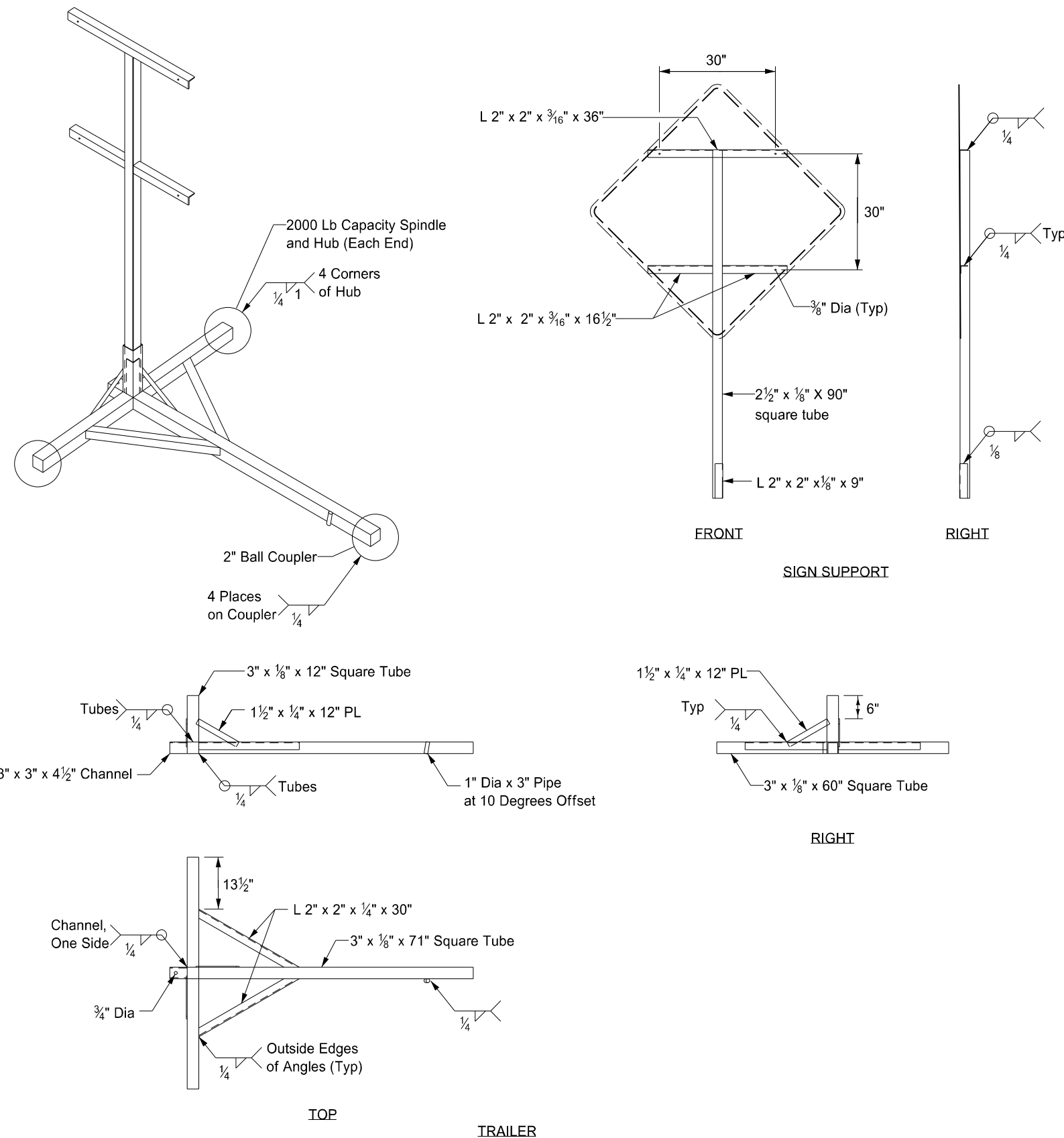

Notes:

- ① Maximum 250 pound weight of assembly.
- ② Use a 14" wheel and tire.
- ③ Use no automotive and equipment axle assemblies for trailer-mounted sign supports.
- ④ Other NCHRP 350 or MASH crash tested assemblies are acceptable.

NORTH DAKOTA DEPARTMENT OF TRANSPORTATION	
11-23-10	
REVISIONS	
DATE	CHANGE
12/02/2020	Updated Note to active voice.

KIRK J. HOFF
 REGISTERED
 PROFESSIONAL
 PE-4683
 ENGINEER
 NORTH DAKOTA
 12 02 2020

Curb & Gutter and Valley Gutter

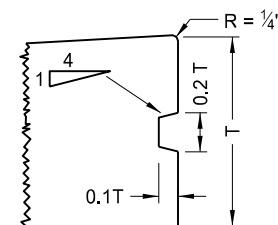
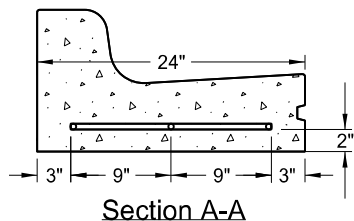
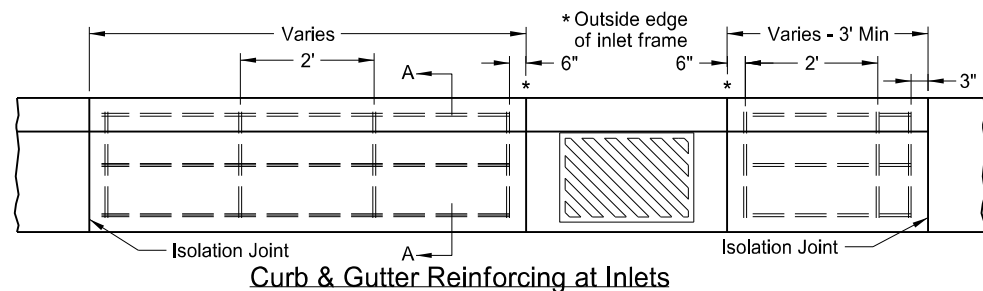

Keyway Detail for Curb & Gutter
(To be used with PCC Pavement and Drives)

T = Thickness of pavement unless otherwise noted on plans.

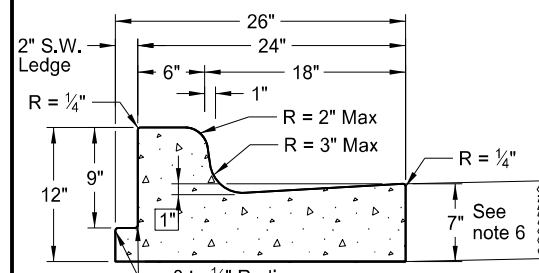

Curb & Gutter Type 1 (Sec. A & B)
Adjacent to Concrete Sidewalk, Median,
or Parking Lot. (Sec. A shown. See
Sec B for additional details.)

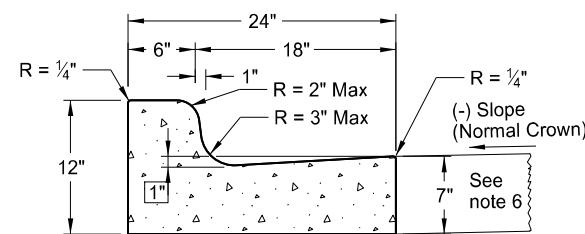

Curb & Gutter Type 1 (Sec. A)

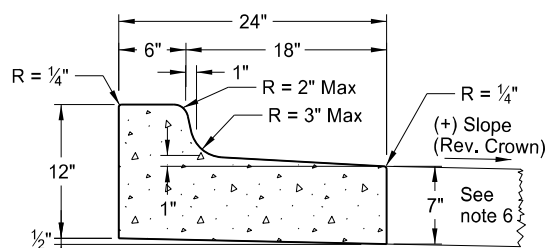

Curb & Gutter Type 1 (Sec. B)

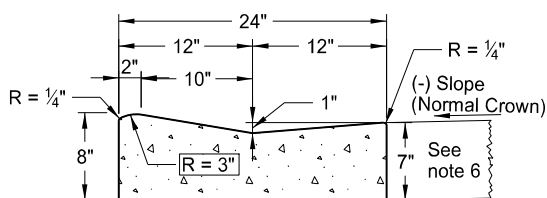

Mountable Curb & Gutter Type 1 (Sec. A)

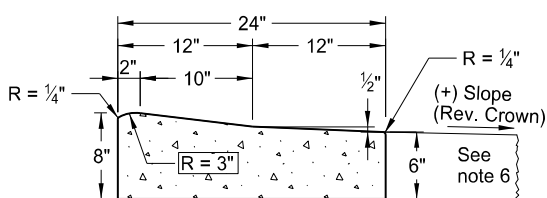

Mountable Curb & Gutter Type 1 (Sec. B)

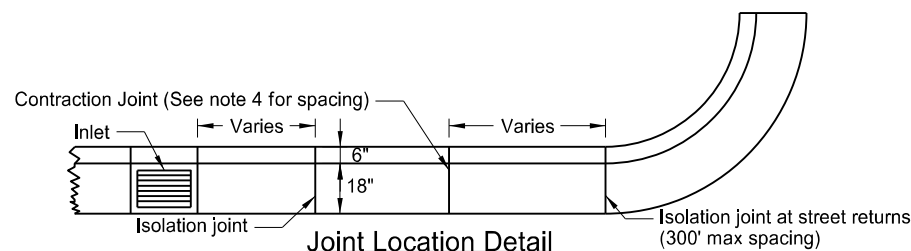

Joint Location Detail

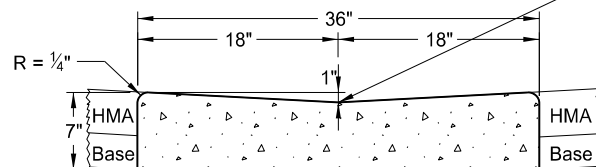

36" Concrete Valley Gutter Detail

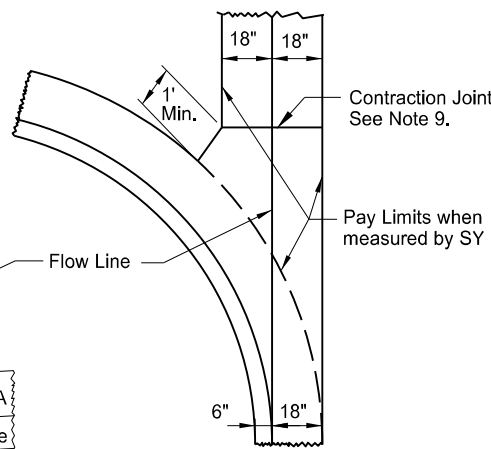

36" Concrete Valley Gutter Plan

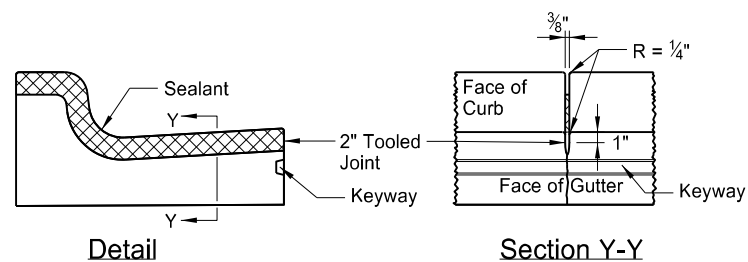

Detail
(10' Max Spacing) Contraction Joint

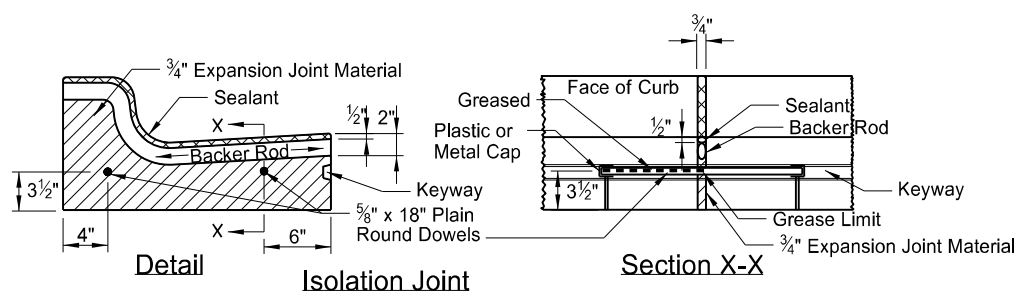

Detail
Isolation Joint

Section X-X

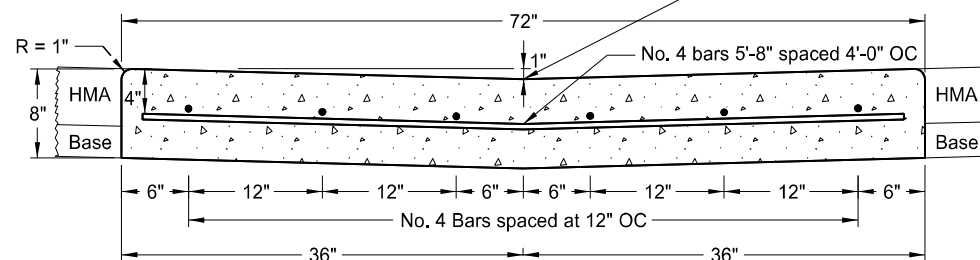

72" Concrete Valley Gutter Detail

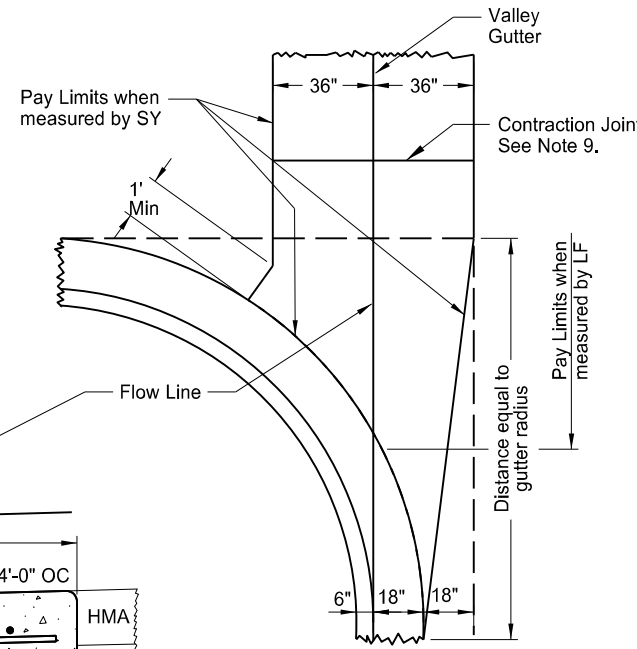

72" Concrete Valley Gutter Plan

NOTES:

1. Use Curb and Gutter Type 1 (Sec. A & B). Use section "A" with (-) pavement slopes and section "B" with (+) pavement slopes.
2. Contraction Joints: Tool the Curb & Gutter 2" as shown on the contraction joint details.
3. Isolation Joints: Use 3/4" expansion joint material for isolation joints. Form the backer rod and joint sealant opening with a pre-cut piece of wood or other material approved by the engineer. Dowel supports are not required on the second pour at a cold joint. Install plastic or metal caps and greased dowels in the cold joint for the second pour.
4. Joint Spacing: For hot mix asphalt pavements use a 10' max joint spacing for the curb and gutter with panels on each side of the inlets. For concrete pavements match the joint spacing for the curb and gutter to the pavement joint on PCC Pavements (approximately 15' spacing.)
5. Joint sealing: For contraction joint, use joint sealant that conforms to section 826.02B. Use sealant for expansion joints specified in note 3 above. Tool and install sealant in accordance with the manufacturer's recommendations.
6. Curb & Gutter-Pavement Interface: For hot mix asphalt pavement use gutter depth shown. For PCC pavements, either match gutter depth to adjacent pavement depth or construct gutter depth shown.
7. Tie curb and gutter to abutting PCC pavement with No. 4 bars, 2'-0" in length, spaced at 3'-9" centers for 15' joint spacing (maximum spacing of 4' centers).
8. On street returns and other locations where new curb and gutter ends and does not abut existing curb and gutter, taper the last two (2) feet of the curb from 6" in height to 0". Install a 1/2" premolded full depth isolation joint (the same shape as the curb and gutter just ahead of the taper) with an 18" plain round bar across the joint.
9. Valley Gutter Joints: Form, saw, or score 1/8" min. to 3/8" max. width contraction joints (a minimum 2" depth) at approx 10' intervals. Seal the joints with hot poured elastic type joint sealer (Section 826.02A.2 of the Standard Specifications.) Include all costs for the joint and sealant in the price bid for Valley Gutter.
10. Reinforcing at Inlets: Use #4 deformed reinforcing bars without splices. Include all costs for reinforcing bars at inlets (even inlets located on radii) in the price bid for "Curb & Gutter - Type 1" or "Curb & Gutter Mountable - Type 1." Extend reinforcement to the second joint (with rebar placed through the first joint) in cases where the 3' minimum panel length can't be obtained.

NORTH DAKOTA DEPARTMENT OF TRANSPORTATION	
8-7-2013	
REVISIONS	
DATE	CHANGE
10-17-17	Updated to active voice.
08-27-19	New Design Engr PE Stamp.
10-30-24	Revised bar size & notes.



10/30/24

SIDEWALK

NOTES:

1. Curb ramp and detectable warning panel layouts for informational purposes only. See Standard Drawing D-750-3 for curb ramp and detectable warning panel details.
2. Joint Spacing: Vary transverse contraction joint spacing from 4' to 6' to create approximate square panels.
Use longitudinal contraction joints when sidewalk width is 8' or greater, and space at half the sidewalk width.
Saw or groove contraction joints to a minimum depth of 1/3 the depth of the concrete.
When sidewalk is adjacent to curb & gutter, vary the sidewalk joint spacing to match curb & gutter joints.
Use isolation joints between separate concrete pours, or between old and new concrete.
3. Include all costs for labor, equipment, and material necessary to construct contraction and isolation joints in the price bid for sidewalk concrete.
4. Use 4" sidewalk concrete thickness unless otherwise specified.
5. Use 4" base material thickness unless otherwise specified. Include all costs for labor and materials necessary to place the base material in the price bid for "Salvage Base Course" or "Aggregate Base Course CL 5."
Modify existing ground slope with landscaping as needed. If not possible, such as adjacent buildings, use a vertical curb as shown in the detail below. The Engineer will measure curb at the unit price bid for "Curb - Type I" per lineal foot.
6. Sidewalk Width & Grade: Provide a continuous 4' min clear width pedestrian access route with max 2% concrete cross slope, excluding flares. The width of the curb cannot be counted as part of the pedestrian access route.
When clear width of pedestrian access routes is less than 5.0', provide passing spaces at a maximum of 200' with a minimum size of 5.0' by 5.0'.

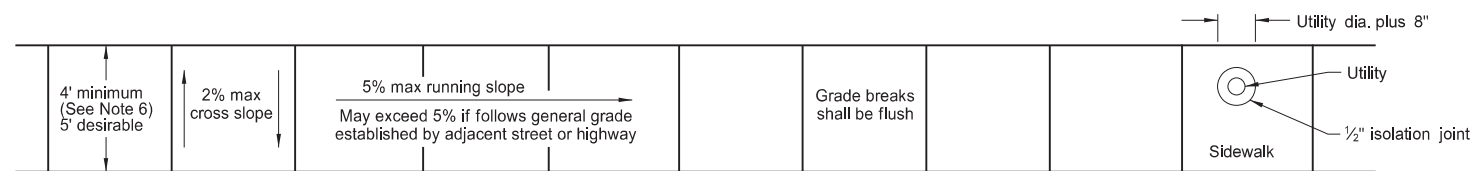
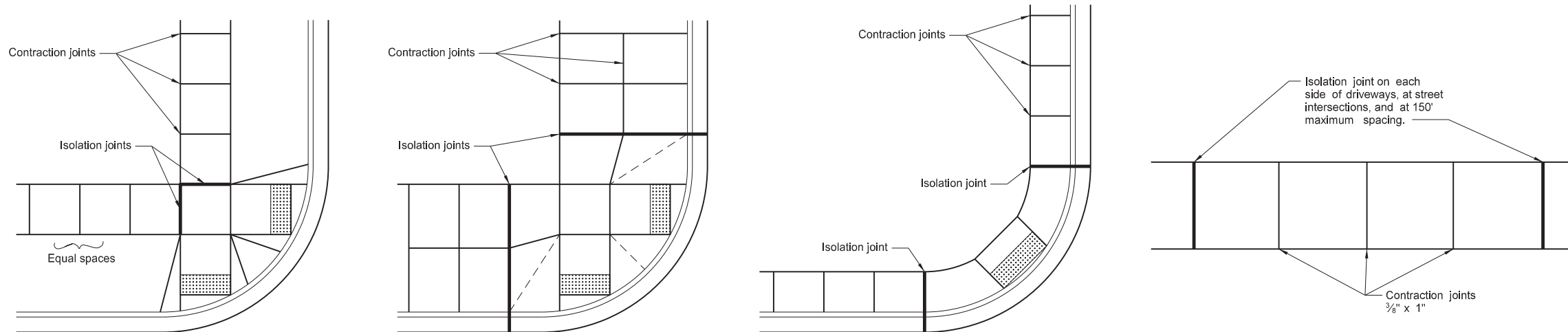

Sidewalk Width and Grade

Utility Blockout

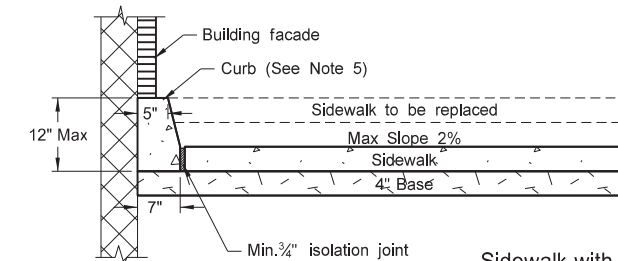

Sidewalk with Curb Detail (Building face application)

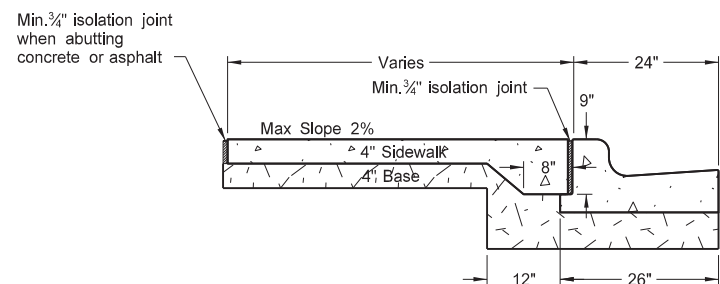

Sidewalk Detail (Installed adjacent to curb and gutter)

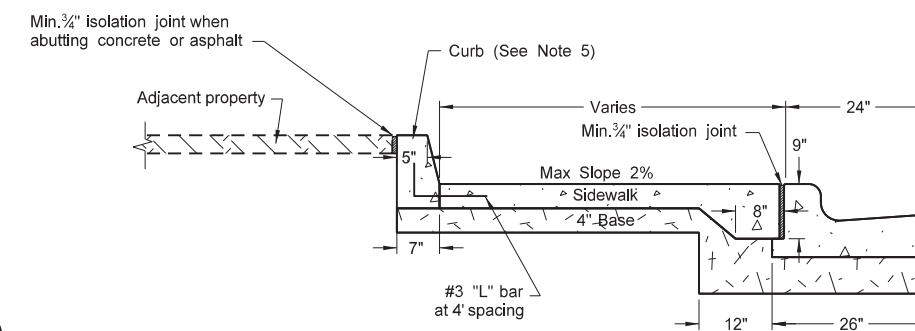
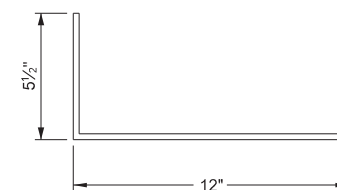
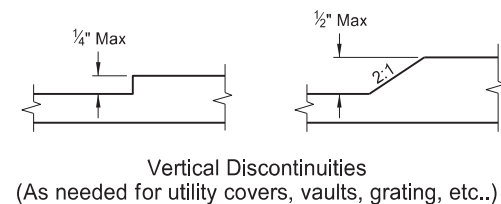

Sidewalk with Curb Detail (Adjacent property application)

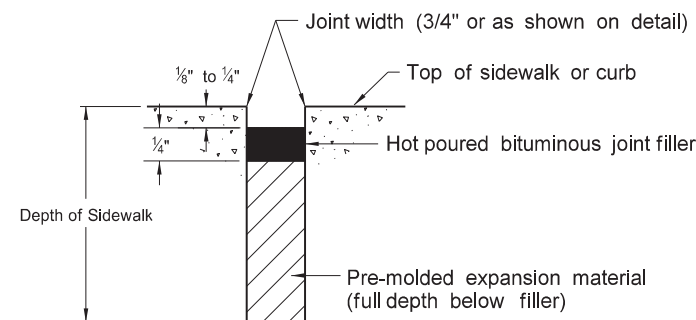
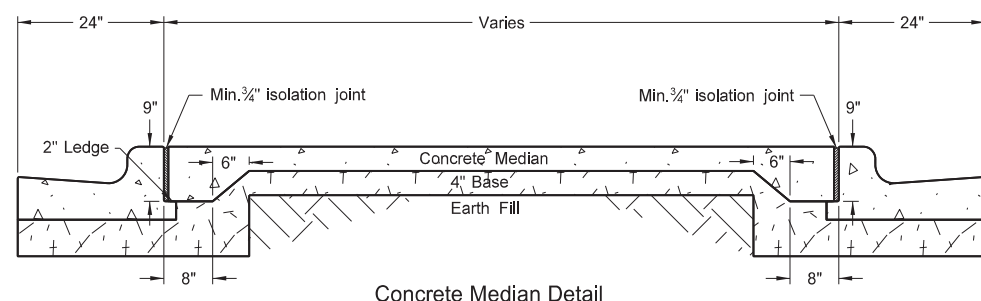

NORTH DAKOTA DEPARTMENT OF TRANSPORTATION	
11-26-13	
REVISIONS	
DATE	CHANGE
10-17-17	Updated to active voice.
09-05-18	Added sidewalk details for width & grade & passing lane requirements.
08-27-19	New Design Engineer PE Stamp.
08-09-24	Electronic Stamp/Signature.



08/09/24

CURB RAMP RETROFIT DETAILS

D-750-3

NOTES:

- Ramp width is the useable portion of the ramp, excluding flares. Match curb ramp width to Existing Pedestrian Facility (EPF) width (4' minimum or 5' for island ramps.) Match ramp width to existing shared use path width. Maximum ramp length is 15'.
- Provide turning space with desirable 5' x 5' size or larger and minimum 4' x 4' unconstrained size, for any change of direction. Provide landing 5' long x width of path at the bottom and top of parallel ramps and at the top of perpendicular ramps. Turning spaces and Landings may overlap.
- Match detectable warning panel width to ramp width. Radial panels are allowed. Place detectable warning panel within the lower turning space.
- Provide a continuous 4' minimum width EPF with 1.5% preferred cross slope and max 2% constructed cross slope.
- Modify existing ground slope with landscaping, as needed. If not possible, use a vertical curb as detailed on Standard D-750-2. The Engineer will measure curb at the unit price bid for "Curb - Type I" per lineal foot.
- Islands: If the profile of the island curb ramp is 2% or less, provide a minimum distance of 2' between warning panels. If the profile of the island curb ramp is steeper than 2%, provide a turning space between the ramps.
- Provide generally planar vertical alignments. Provide grade breaks, perpendicular to the direction of the pedestrian travel, at the top and bottom of curb ramps (1.5% preferred, 2% max constructed cross slope).
- See Curb Ramp Retrofit Details Standard D-750-4 for additional information. Also See PROWAG for full compliance in the curb ramp area.
- Grade transitions shall be flush.

LEGEND:

- : Detectable Warning Panel.
- : Landscaping.
- : Transitional tie-in to nearest joint, if needed.
- : Curb Ramp Retrofit Transitional Area (See Standard Drawing D750-4)
- : 4' long x width of EPF or 4' minimum Clear space outside traffic lanes of travel. 1.5% preferred cross slope 2% maximum cross slope 4.7% preferred running and counter slope 5% maximum running and counter slope
- : Turning Space Use at top of ramp or when changing directions. 1.5% preferred slope (2% maximum) all directions.
- : Preferred Ramp Grade = 5% to 7.5%. Maximum Constructed Grade = 8.3%. Preferred Cross Slope = 1.5%. Maximum Constructed Cross Slope = 2%.
- : 1.5% preferred cross slope 2% maximum constructed cross slope running slope consistent with the EPF 4.7% preferred max counter slope 5.0% max constructed counter slope
- : 10:1 maximum constructed slope.
- : 4:1 maximum constructed slope.
- 0", 3", or 6" : Curb Height.

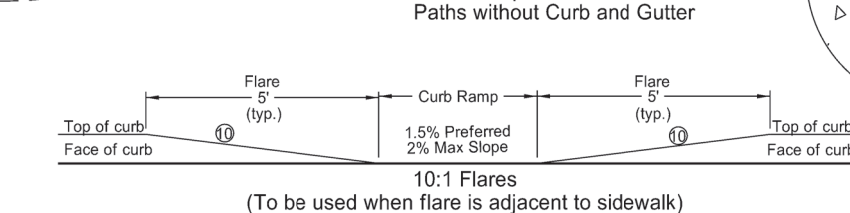
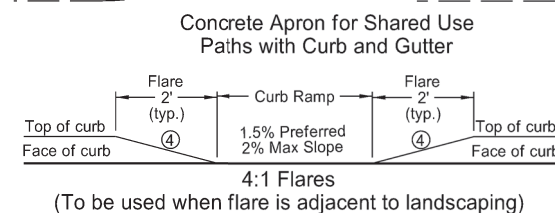
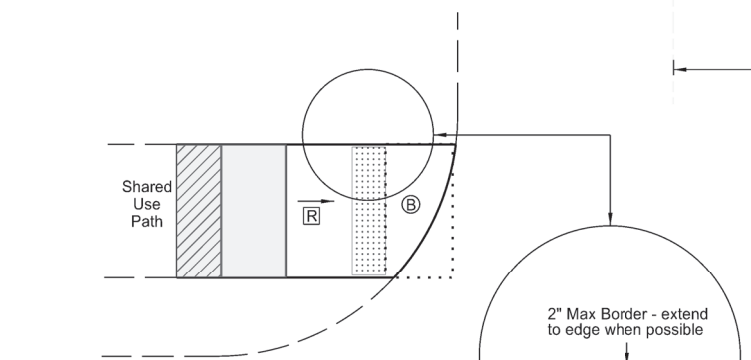
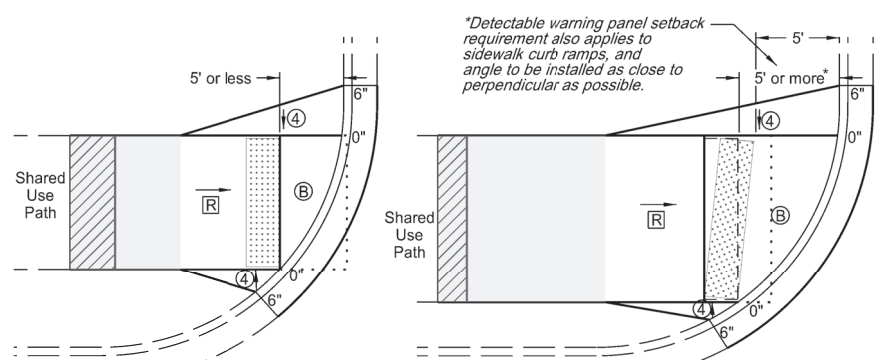
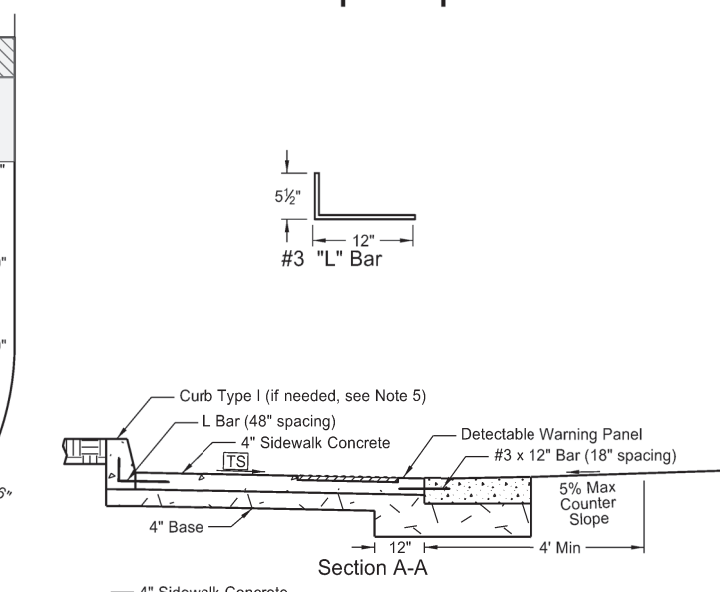
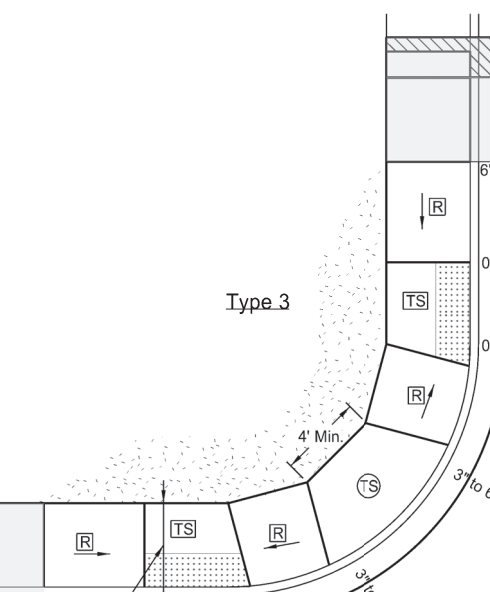
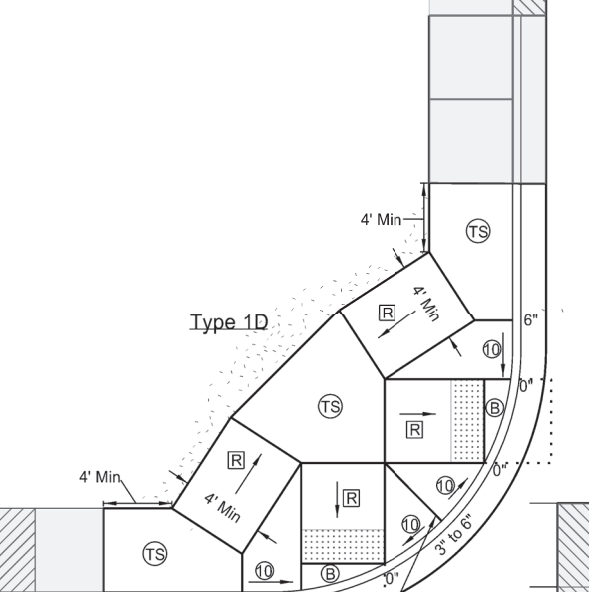
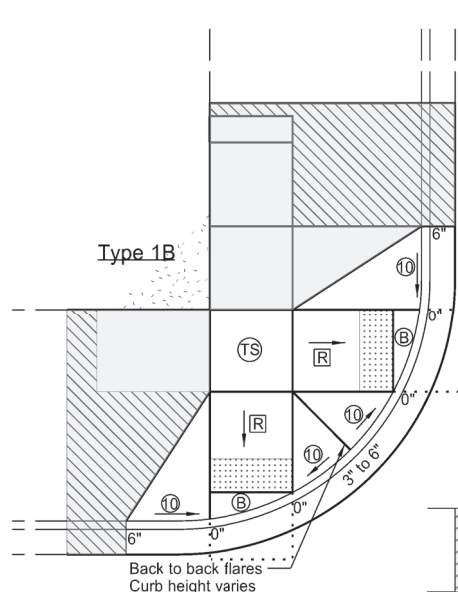
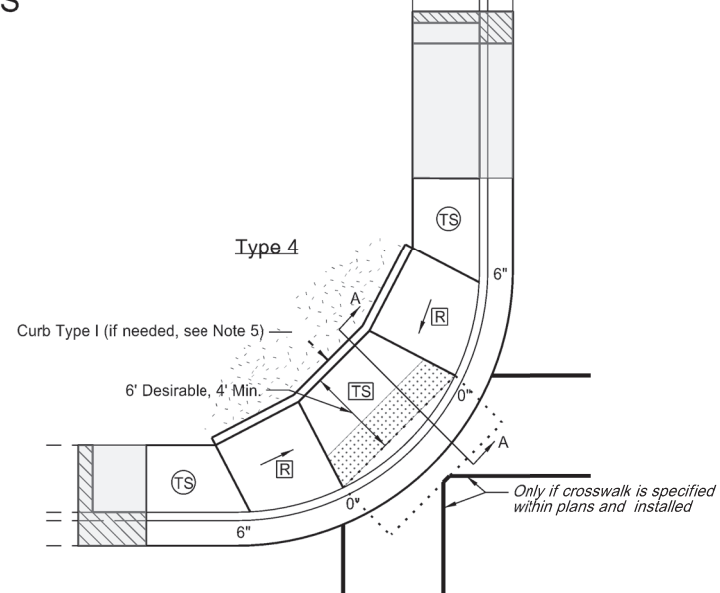
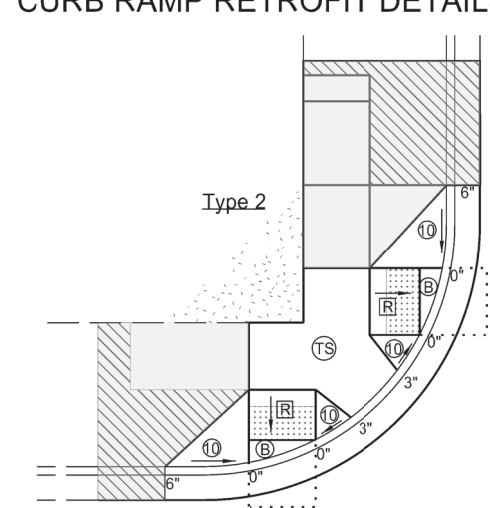
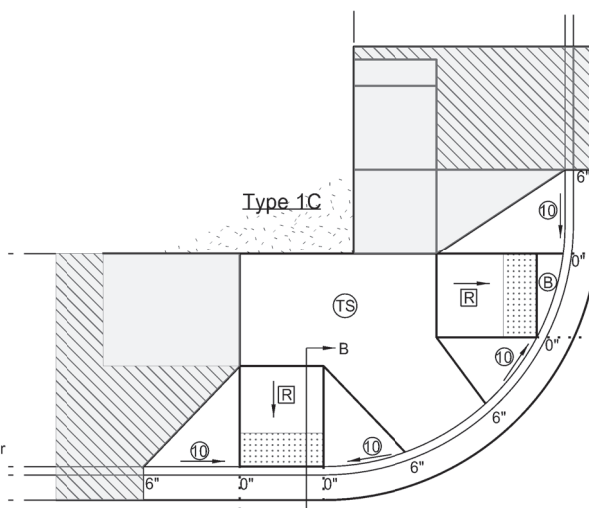
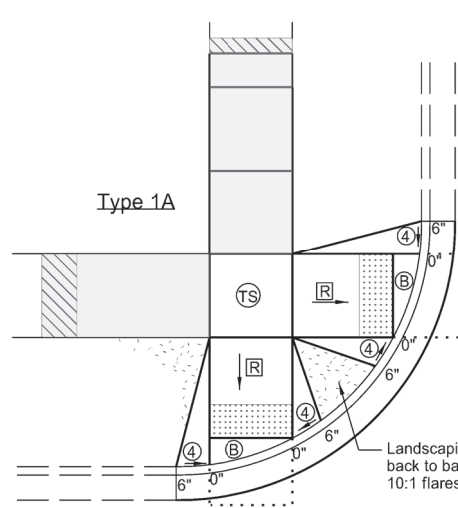

Median Refuge Islands (Cut-Through)

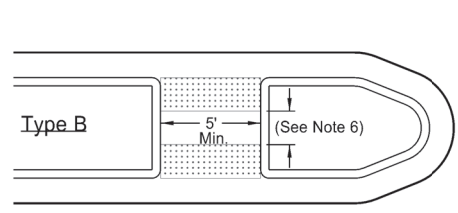
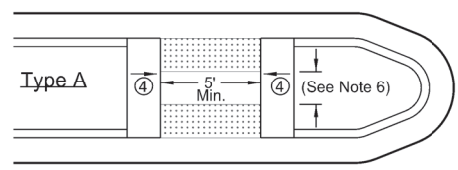

NORTH DAKOTA DEPARTMENT OF TRANSPORTATION	
11-26-13	
REVISIONS	
DATE	CHANGE
10-17-17	Updated to active voice.
09-05-18	Revised Notes, Revision for Turning Space, Added Passing Space Requirements, Turned Detectable Warning Panel
03-15-21	Slope & other clarifications.
05-19-21	Separate Curb Ramp Transition Area from Curb Ramp area

CURB RAMP RETROFIT TRANSITIONAL AREA DETAILS

D-750-4

NOTES:

1. Curb Ramp Transitional Areas are to transition from the Curb Ramp area into the Existing Pedestrian Facility (EPF). Each layout shows example transitions. Use any combination for transitions from the Ramp Area into the EPF that allows for similar or gentler slopes to that of the existing condition, yet transitions in the shortest distance possible. In some cases, if grades allow, the Ramp area can immediately transition into the EPF and no transitional area is needed.
2. Option 1: Use this transition when existing running slope grades are less than 5%. Transition from the ramp area to the EPF using the Pedestrian Access Transition Area (PTA) transition rates and in less than 20 feet.
3. Option 2: Use this transition when existing running slopes are greater than 5% and option 1 is not able to be met.

Add a ramp and a landing immediately after the ramp area. Then transition from the compliant landing into the EPF using the PTA rates (preferred), or in less than 15 feet (which ever is shorter).
4. Transitional Areas for Shared Use Paths can be concrete or asphalt.
5. See Curb Ramp Retrofit Details Standard D-750-3 for additional information.

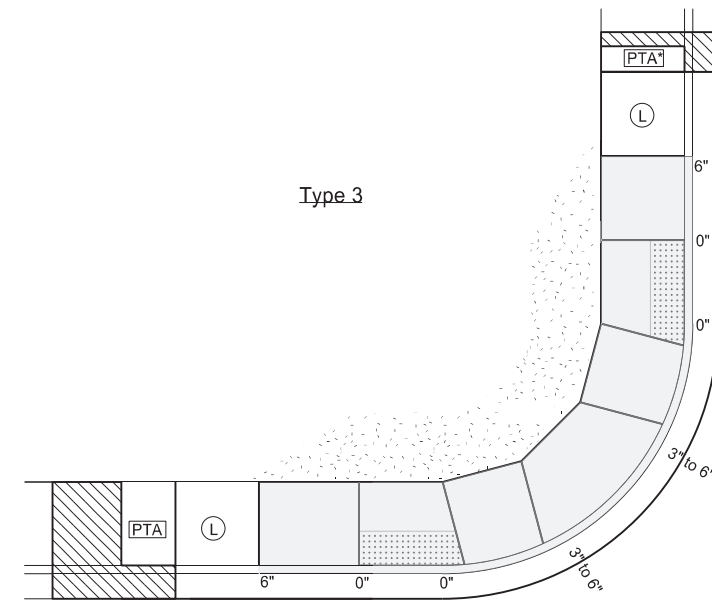
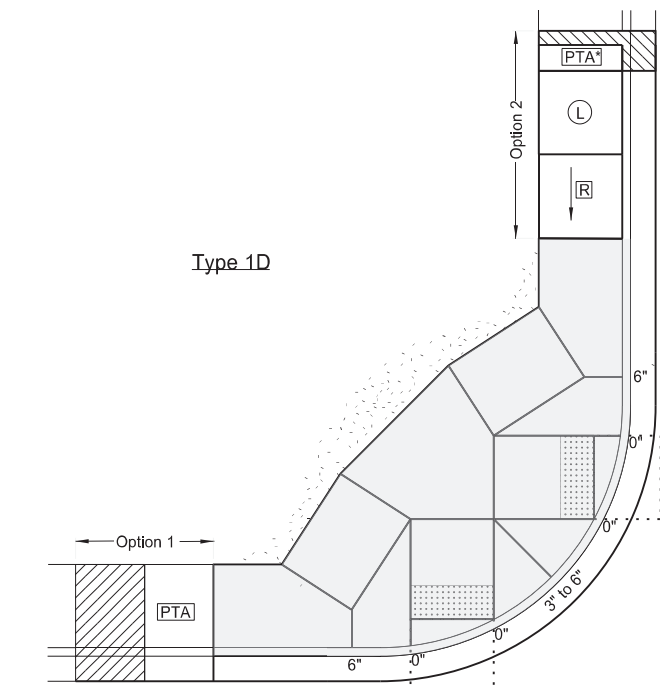
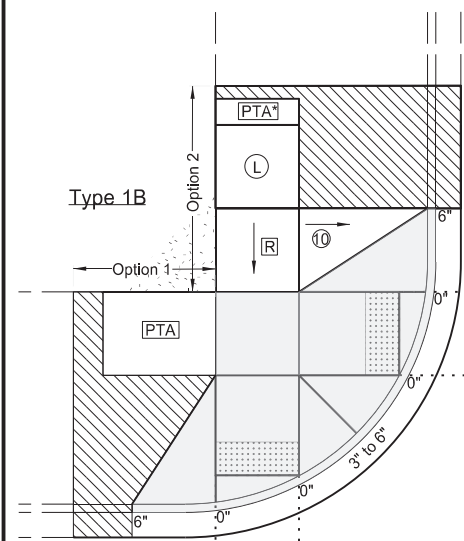
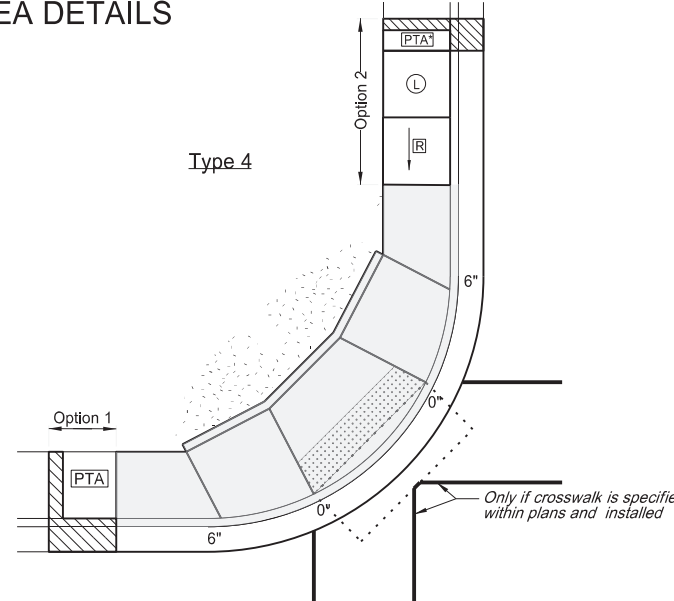
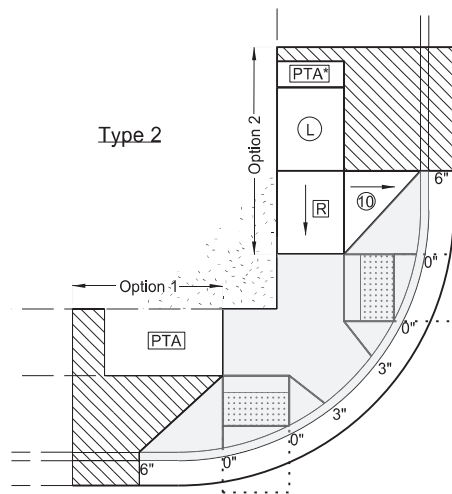
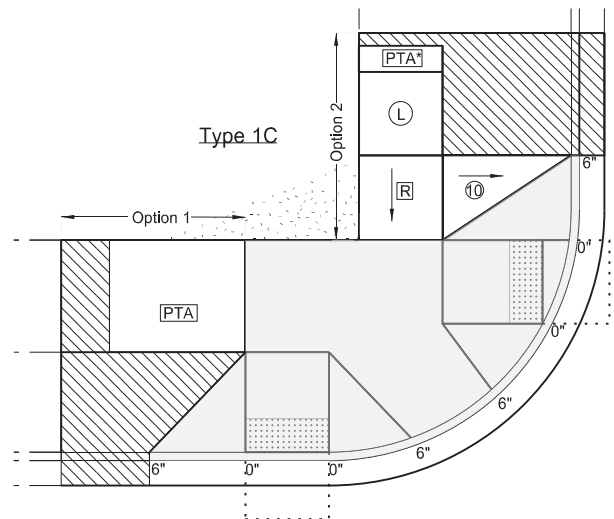
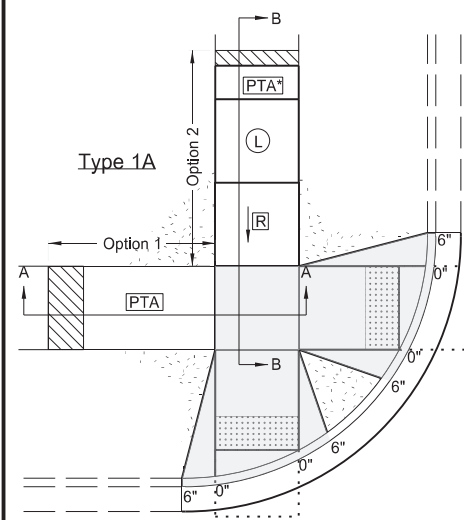

LEGEND:

- : Detectable Warning Panel.
- : Landscaping.
- : Transitional tie-in to nearest joint, if needed.
- : Curb Ramp Retrofit Area (See Standard Drawing D750-3)
- : 4' long x width of EPF or 4' minimum Clear space outside traffic lanes of travel. 1.5% preferred cross slope 2% maximum cross slope 4.7% preferred running slope 5% maximum running slope
- PTA** : Pedestrian Access Transition Area Running Slope less than 4.9%. Transition Cross Section at 1/2 percent per foot from the Ramp Area to EPF.
- L** **TS** : Turning Space/Landing Use at top of ramp or when changing directions. 1.5% preferred slope (2% maximum) all directions.
- R** : Preferred Ramp Grade = 5% to 7.5%. Maximum Constructed Grade = 8.3%. Preferred Cross Slope = 1.5%. Maximum Constructed Cross Slope = 2% Maximum Length = 15 feet
- 10** : 10:1 maximum constructed slope.
- 4** : 4:1 maximum constructed slope.
- 0", 3", or 6" : Curb Height.

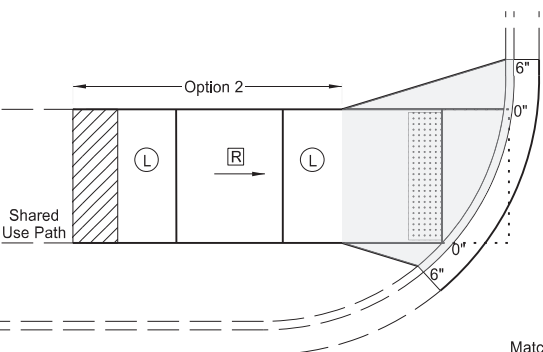
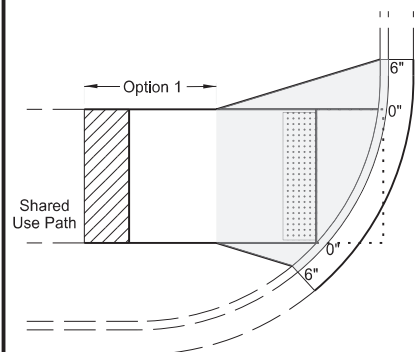

Transition Areas for Shared Use Paths

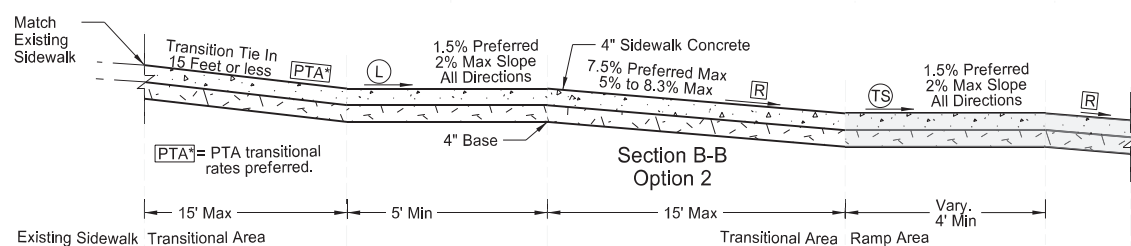
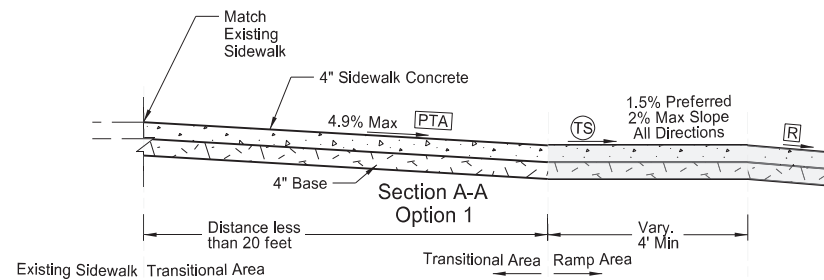

NORTH DAKOTA DEPARTMENT OF TRANSPORTATION	
05-19-21	
REVISIONS	
DATE	CHANGE

KIRK J. HOFF
REGISTERED
Kirk J Hoff
PROFESSIONAL
PE-4683
ENGINEER
NORTH DAKOTA
05 19 2021

LIGHT STANDARD, SIGNAL STANDARD,
AND SPAN WIRE MOUNTED SIGN
ASSEMBLY DETAIL

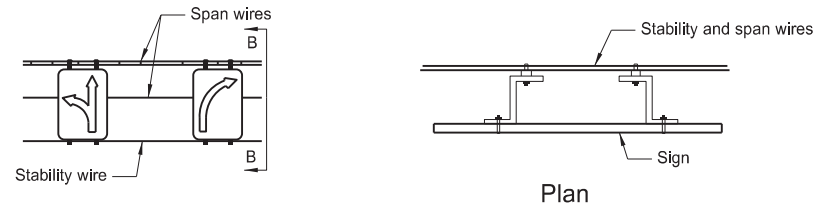

Plan

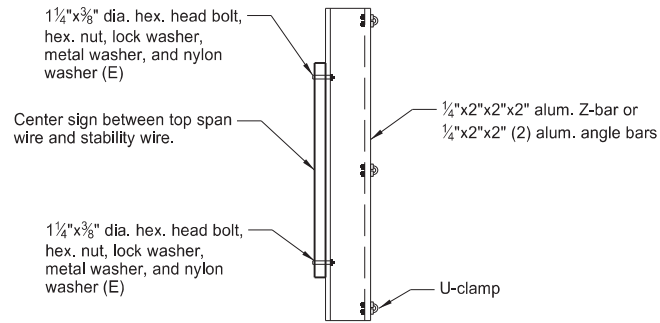

Section B-B
Span Wire Mounted Sign Detail

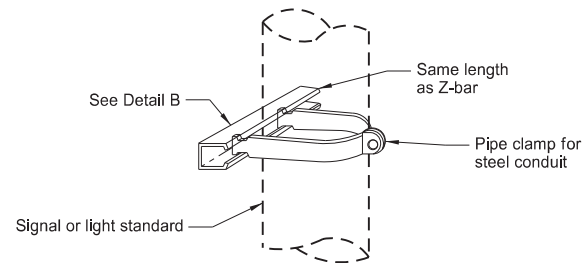

Vertical Mounting
(Use 2 clamps per sign)

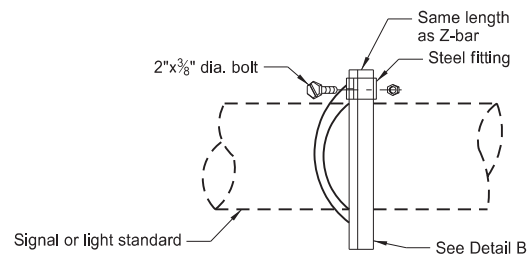

Horizontal Mounting
alternate clamp mounting
(Use 2 clamps per sign)

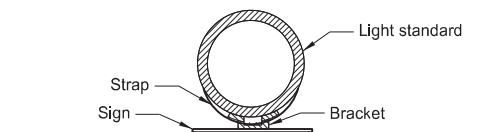

Light Standard Mounted Sign Bracket Detail
Max. 24"x30" signs (D)

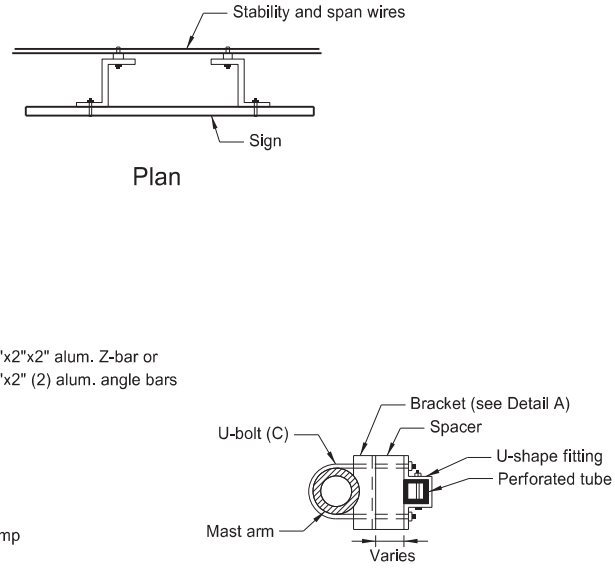

Section A-A

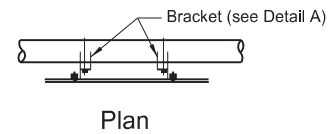

Plan

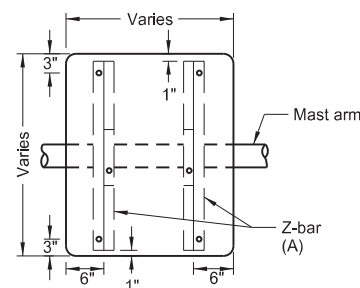

Elevation

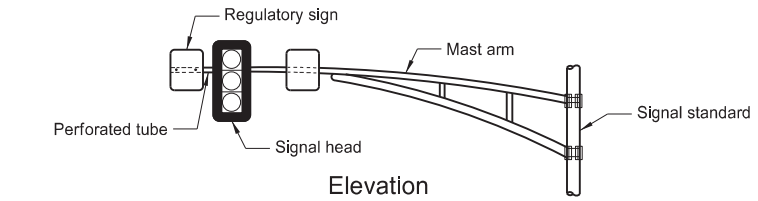

Elevation



Plan

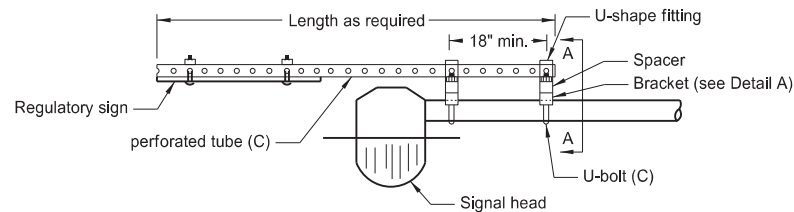

Sign Mounted Beyond End of Mast Arm Detail

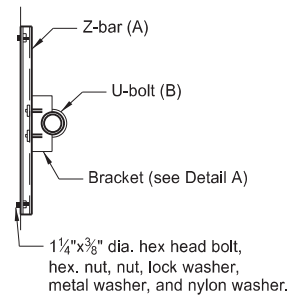

Side View

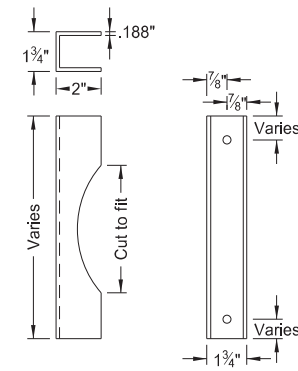

Detail A

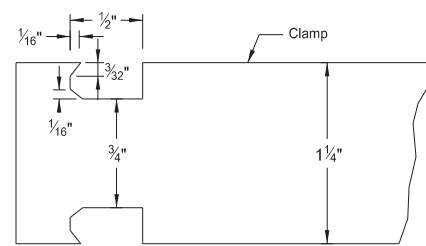

Clamp Detail

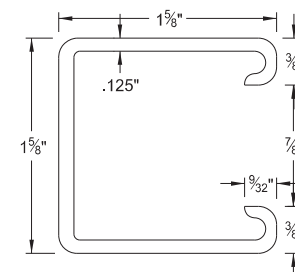

Detail B
Steel Channel

Post Size dia.	Clamp Gauge min.
3 1/2" to 5"	11
6" to 12"	10

Clamp	
Post Size dia. in.	D in.
3 1/2	3
4	3 3/16
5	5 1/8
6	7 1/16
8	13 1/16
10	20 3/4
12	29 5/8

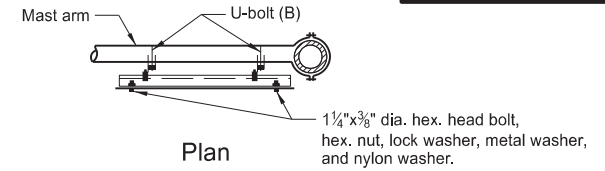

Plan

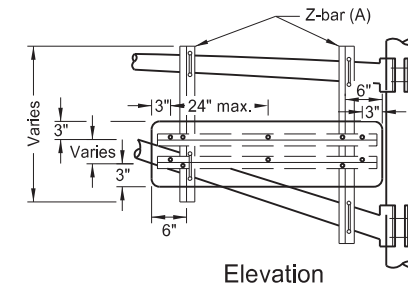

Elevation

Mast Arm Mounted Street Name Sign Detail

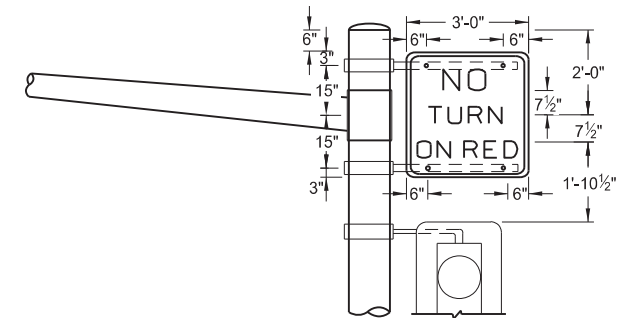

Signal Standard Mounted Sign Attachment Detail

Notes:

- (A) Use 1 3/4" x 3/16" thick 1.08 lb/ft aluminum alloy Z-bar. In place of Z-bar, use two 1 3/4" x 1 3/4" x 3/16" angles bolted together or a 1 3/4" x 2" x .188" channel.
 - (B) 3/8" U-bolt, hex. nut, lock washer, and bracket (U-bolt length depends on dia. of mast arm.)
 - (C) 3/8" U-bolt, hex. nut, lock washer, and bracket (U-bolt length depends on dia. of mast arm.)
- Maximum perforated tube lengths for mounting signs beyond end of mast arm:
 2" x 2" maximum support length 9.9'
 2 1/4" x 2 1/4" maximum support length 12.6'
 2 1/2" x 2 1/2" maximum support length 15.7'
- (D) Use galv. steel strap and sign attachment bracket similar to the one shown in the detail. Include all costs of bracket assembly in the price bid for flat sheet signs. Punch as shown on Standard Drawings. Provide a 7' minimum vertical clearance to the bottom of signs mounted on light standards.
 - (E) Use metal washers and nylon washers with a minimum outside dia. of 1 5/16" ± 1/16" and 10 gauge thickness on sign face.

NORTH DAKOTA DEPARTMENT OF TRANSPORTATION	
10-3-13	
REVISIONS	
DATE	CHANGE
8-30-18	Updated notes to active voice.
9-05-19	New Design Engineer PE Stamp.
8-08-24	Electronic Stamp/Signature.



08/08/24

PAVEMENT MARKING

D-762-4

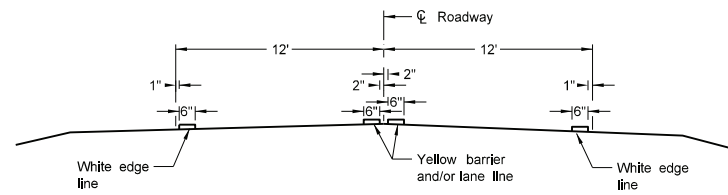

Two Lane Two Way
RURAL ROADWAY

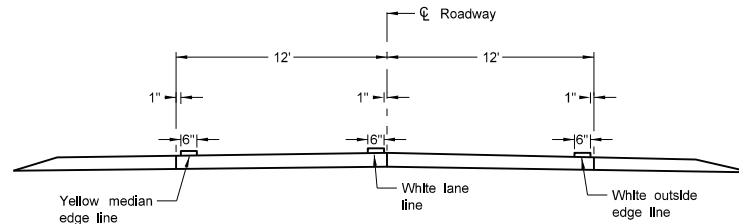

Two Lane Roadway
INTERSTATE HIGHWAY
Concrete Section

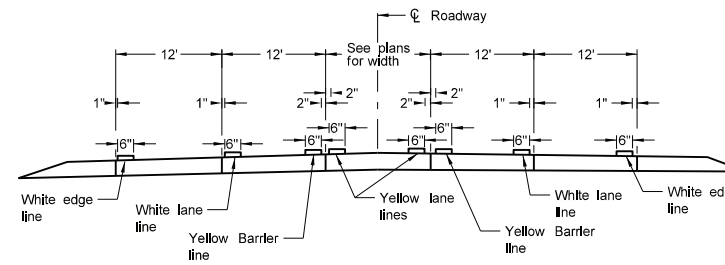

RURAL FIVE LANE ROADWAY
Concrete Section

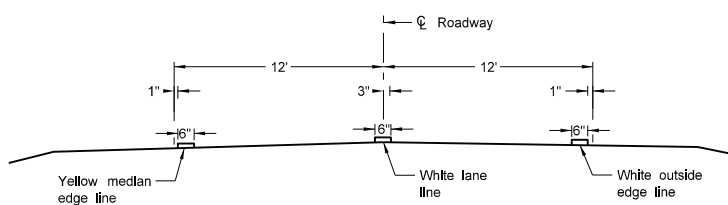

Two Lane Divided
Rural Roadway
PRIMARY HIGHWAY
Asphalt Section

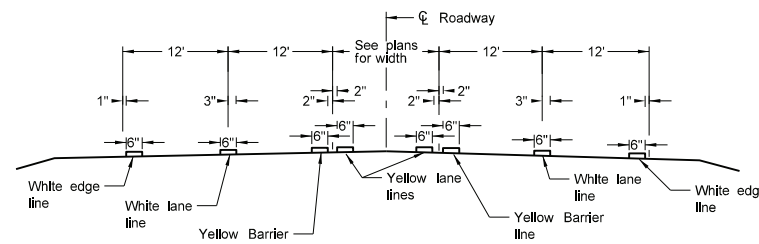

RURAL FIVE LANE ROADWAY
Asphalt Section

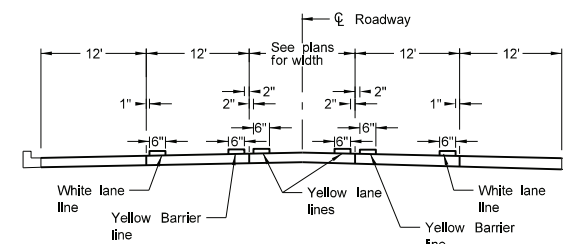

URBAN FIVE LANE SECTION
Concrete Section

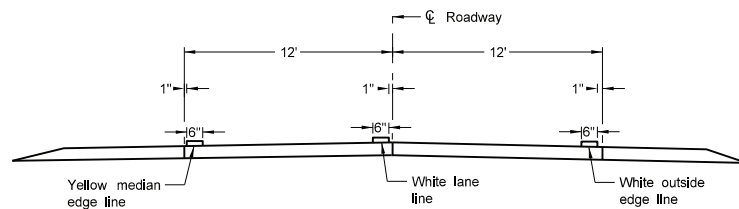

Two Lane Divided
Rural Roadway
PRIMARY HIGHWAY
Concrete Section

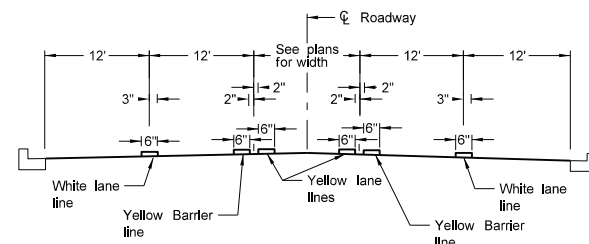

URBAN FIVE LANE SECTION
Asphalt Section

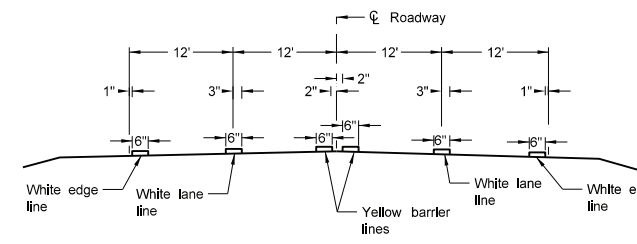

RURAL FOUR LANE ROADWAY
Asphalt Section

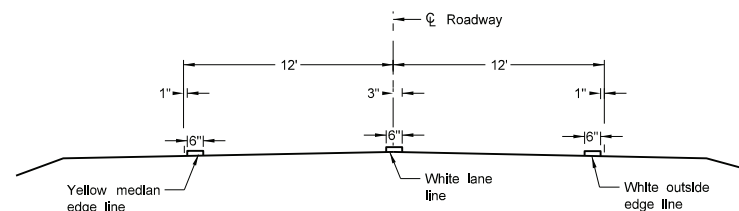

Two Lane Roadway
INTERSTATE HIGHWAY
Asphalt Section

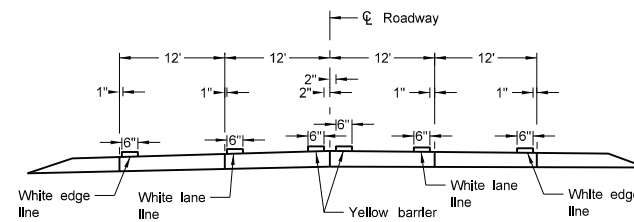

RURAL FOUR LANE ROADWAY
Concrete Section

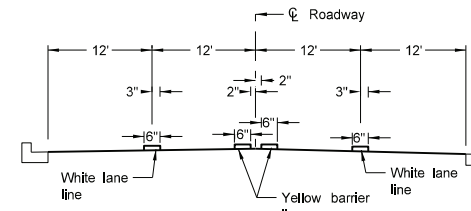

URBAN FOUR LANE SECTION
Asphalt Section

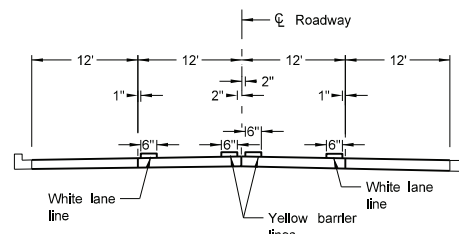

URBAN FOUR LANE SECTION
Concrete Section

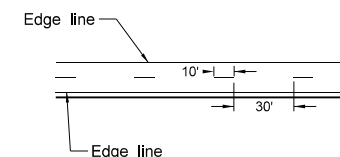

CENTERLINE PAVEMENT MARKING SKIP SPACING DETAIL

NOTES:

1. Continue edge lines through private drives and field drives. Break edge lines for intersections.

For section lines, county roads, and street approaches, stripe the radii and edge lines of the paved surface within the right of way except where curb and gutter is present.
2. Normal width line - 6 inches wide for freeways, expressways, and ramps; 6 inches for all other roadways with speed limits > 40 mph,
3. Use 4 or 6 inch wide pavement marking for all other roadways with speed limits < 40 mph.

NORTH DAKOTA DEPARTMENT OF TRANSPORTATION	
12-1-10	
REVISIONS	
DATE	CHANGE
10-17-17	Updated to active voice.
08-27-19	New Design Engineer PE Stamp.
11-22-23	Revised pavement marking widths.
07-09-24	Modified Note 1.



**CONCRETE FOUNDATIONS
(TRAFFIC SIGNALS & HIGHWAY LIGHTING)**

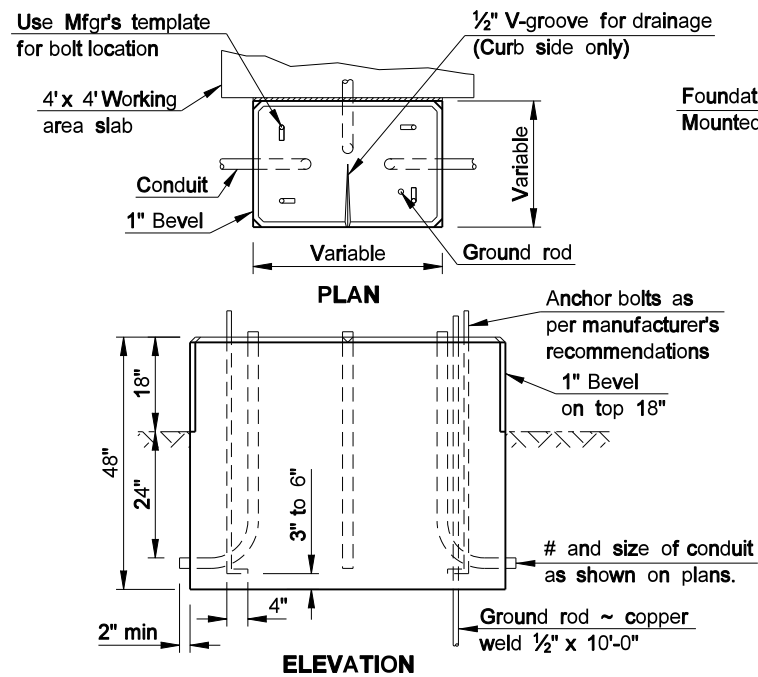

CONTROLLER CABINET FOUNDATION PAD MOUNT

The Controller Cabinet Foundation shall be bid as Concrete Foundation - Traffic Signals.

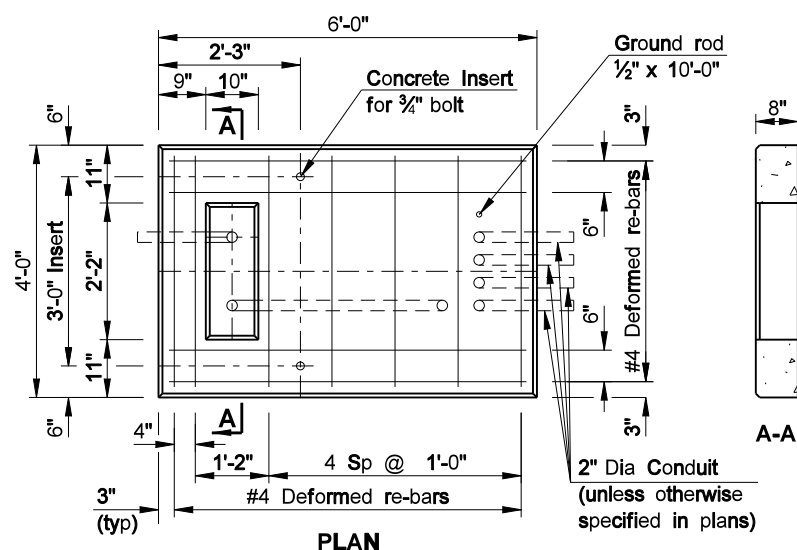

TRANSFORMER & FEED POINT CABINET FOUNDATION PAD MOUNT

The Transformer & Feed Point Cabinet Foundation Pad Mount shall be bid as Concrete Foundation ~ Feed Point ~ Type A.

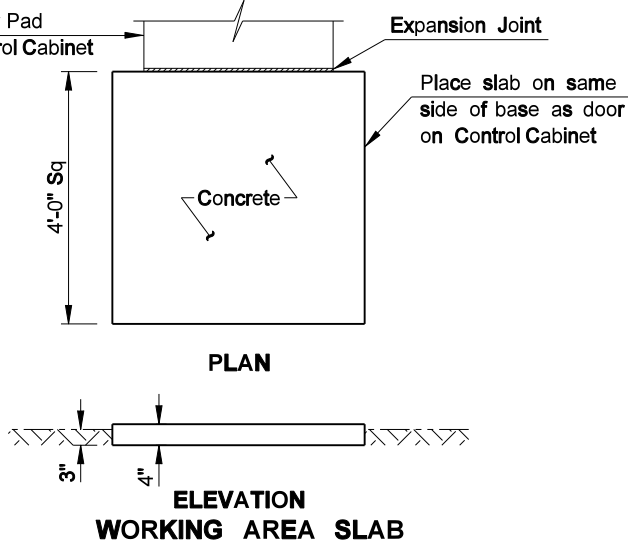

The Working Area Slab shall be installed where shown on the plans and shall not be bid separately but shall be included in the price bid for Concrete Foundation - Traffic Signals.

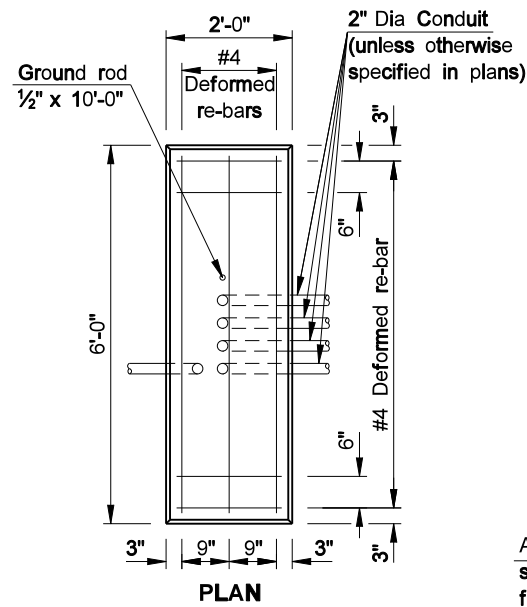

FEED POINT CABINET FOUNDATION PAD MOUNT

The Feed Point Cabinet Foundation Pad Mount shall be bid as Concrete Foundation ~ Feed Point ~ Type B.

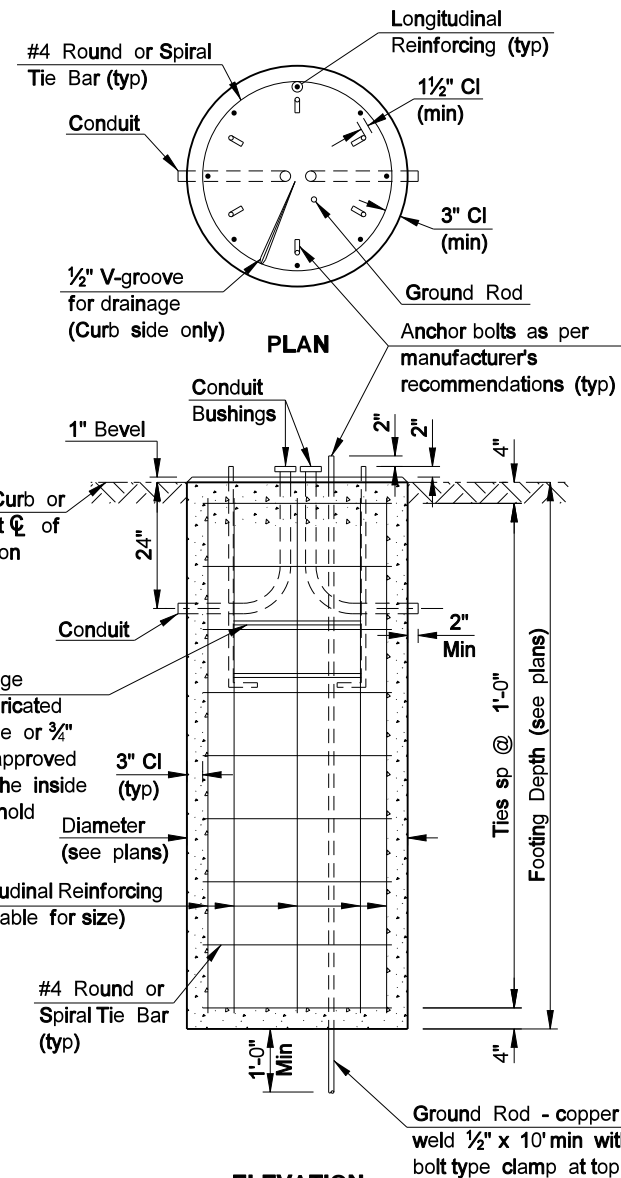
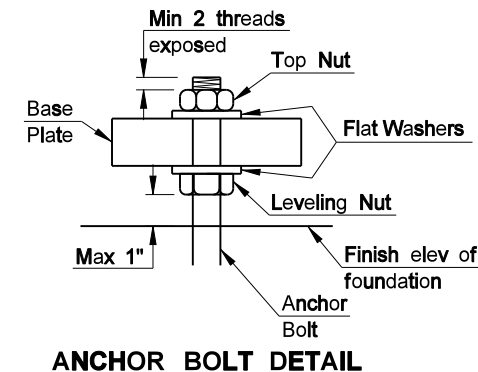

LIGHT & SIGNAL STANDARD FOUNDATION

NOTES:
LIGHT & SIGNAL STANDARD FOUNDATIONS: See plans for conduit size, number of bends and correct position for each foundation. When conduit does not continue beyond the foundation, conduit with a 105° bend and bushings on both ends may be substituted for the 90° bends shown. See plans for correct size & location of foundations. The grade and exact location shall be established by the Engineer in the field. All reinforcing shall be Grade 60. Tie bars shall have a minimum of a 12" lap. Reinforcing may be omitted for Type I, II, V, VI & VII signal standard foundations if the anchor bolts extend to within 3" to 6" above the bottom of the foundation. A minimum of 6 anchor bolts shall be used for cantilevered structures.

CONTROLLER CABINET FOUNDATION PAD MOUNT FOUNDATION: See plans for the number of 90° bends per foundation and correct positioning. The foundation for Pad Mounted Controller Cabinet shall be of sufficient size so that there is a minimum of 3" of clearance from the outside edge of cabinet to the outside edge of the foundation on any side. The contractor shall ensure a water-tight seal between the controller cabinet and the foundation by caulking, except for V-groove.

WORKING AREA SLAB: The materials and preparation of this slab shall be as approved by the Engineer in the field.

TRANSFORMER & FEED POINT CABINET FOUNDATION PAD MOUNTED: The foundation shall have a wood float finish. All conduits shown shall be installed. Conduit that is not used at this time shall be plugged with an expandable plug.

FEED POINT CABINET FOUNDATION PAD MOUNTED: The foundation shall have a wood float finish. All conduits shown shall be installed. Conduit that is not used at this time shall be plugged with an expandable plug.

LIGHT & SIGNAL FOUNDATION TABLE	
FOOTING DEPTH (ft)	LONGITUDINAL REINFORCING
≤ 12	8 - #5
13 - 14	8 - #6
15 - 16	8 - #7
17 - 19	8 - #8

NORTH DAKOTA DEPARTMENT OF TRANSPORTATION	
6-15-10	
REVISIONS	
DATE	CHANGE

This document was originally issued and sealed by Terrence R. Udland Registration Number PE- 2674 , on 6/15/10 and the original document is stored at the North Dakota Department of Transportation

FEED POINTS (ROADWAY LIGHTING)

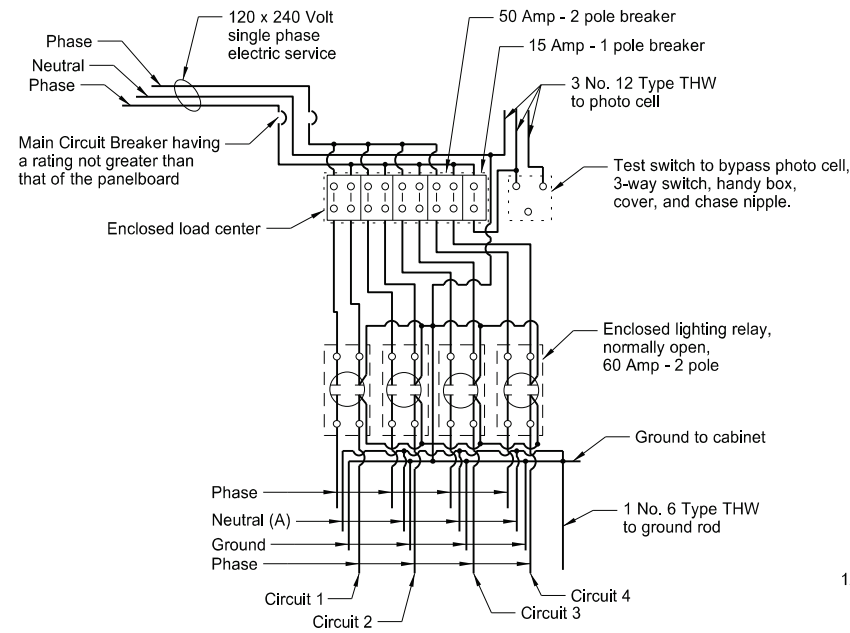
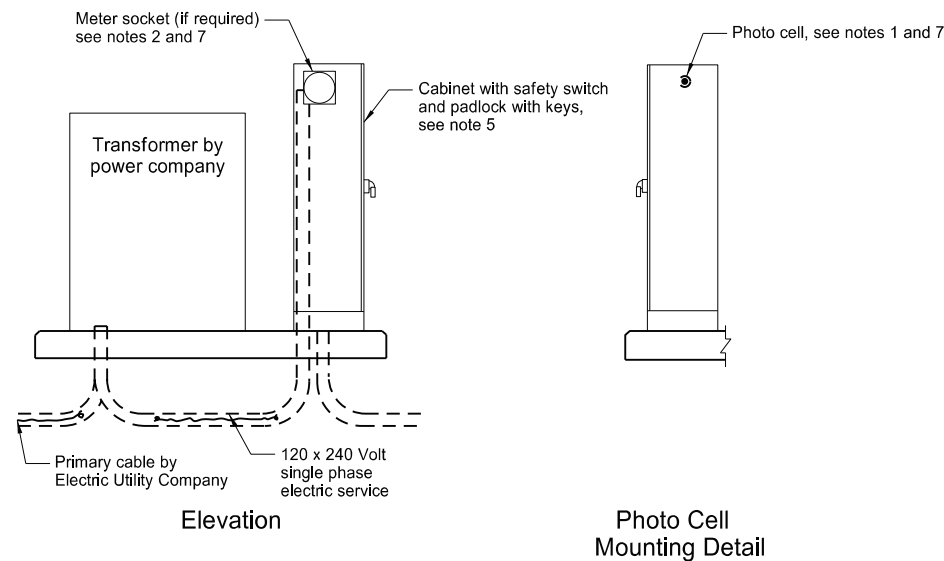

Feed Point Type IV

Provide Type I feed point similar to Type IV, except with one electrical circuit, one 50 Amp - 2 pole breakers, and one lighting relay, normally open.

Provide Type II feed point similar to Type IV, except with two electrical circuit, two 50 Amp - 2 pole breakers, and two lighting relays, normally open.

Provide Type III feed point similar to Type IV, except with three electrical circuits, three 50 Amp - 2 pole breakers, and three lighting relays, normally open.

(A) Install when festoon circuit is required.

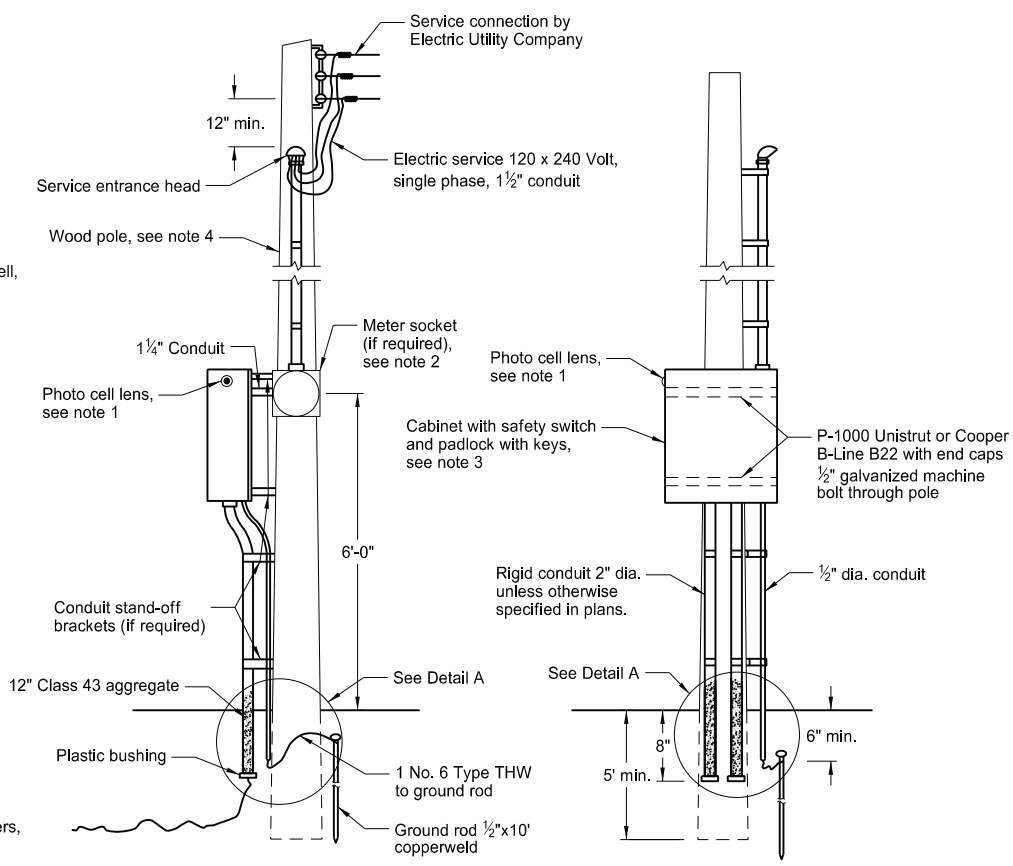

Feed Point Pole Mounted

- Notes:
1. Photo Cell: Furnish and install the photoelectric cell. Face photo lens north.
 2. Meter Socket: Install meter socket and trim if the meter is required by local Utility Company. Meter furnished and installed by Utility Company.
 3. Pole Mounted Cabinet: Provide cabinet with lock drip shield, factory installed steel backing, stainless steel hardware, and side hinge door. Shop coat cabinet with one coat of primer and two coats of exterior gray enamel.
- Provide 30" high x 24" wide x 8" deep Type I and II feed points. Provide 30" high x 42" wide x 10" deep or 36" high x 36" wide x 10" deep Type III and IV feed points.
4. Wood Pole: Provide minimum 20' Class VII full length penta pressure treated wood pole. (if required, see layout sheets)
 5. Pad Mounted Cabinet: Provide 56" high x 26" wide x 14" deep weatherproof cabinet. Minimum 12 gauge steel or aluminum with provisions for padlock.
 6. Grounding Grid: Provide grounding grid with a maximum ground resistance of 25 ohms, using one or more 5/8"x10" copperweld ground rods in parallel or series at two corners. Provide a minimum distance between ground unit assemblies of 6'0".
 7. Meter Location: Do not mount the meter (if required) on the same side of the cabinet as the photo cell.

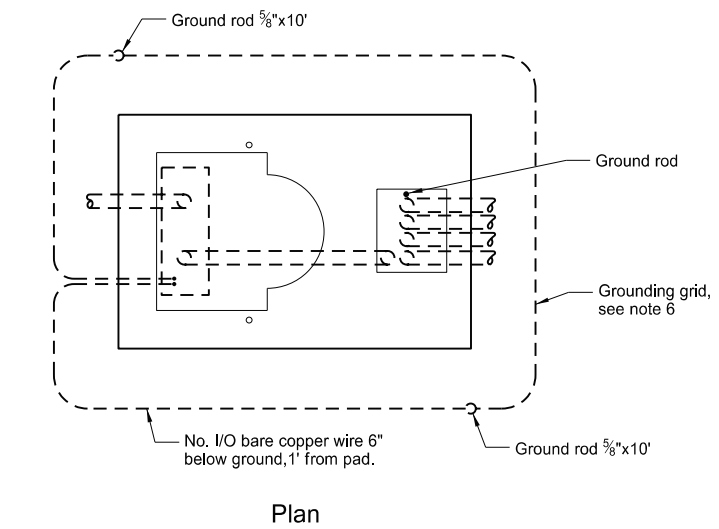

Plan
Transformer and Feed Point Cabinet Pad Mounted

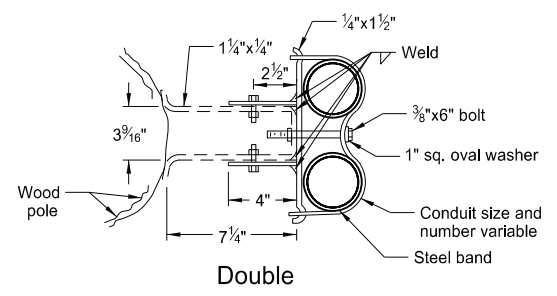

Double

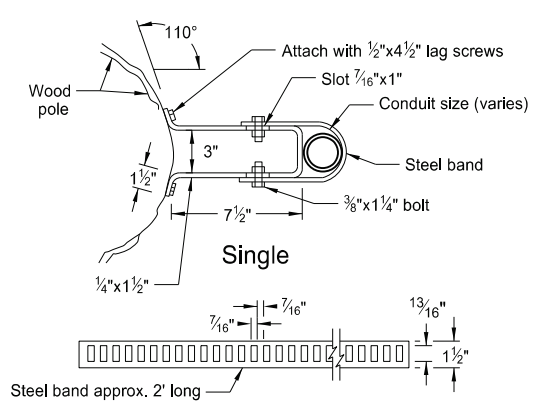

Single

Conduit Standoff Bracket

Omission of conduit standoff brackets allowed when not required by local utility company.

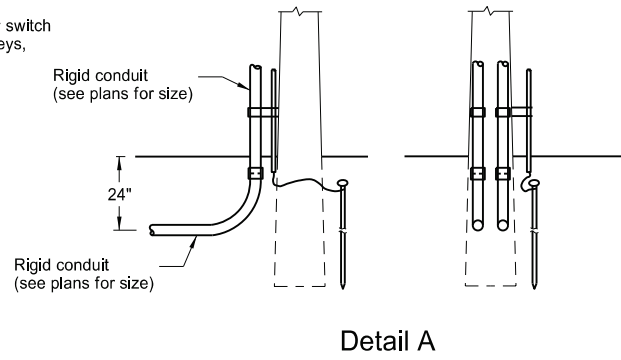

Detail A

Use this detail for a continuous run of conduit from the feed point to the first light standard.

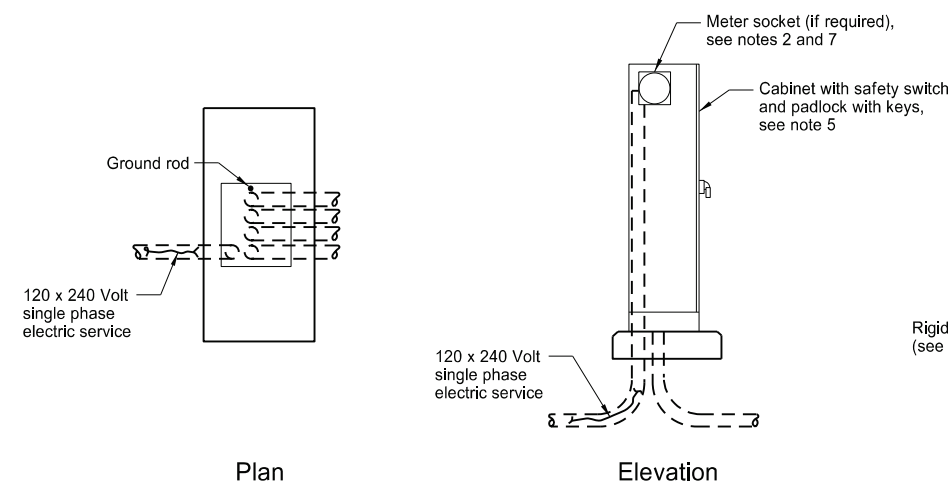

Plan
Elevation
Feed Point Cabinet Pad Mounted

NORTH DAKOTA DEPARTMENT OF TRANSPORTATION	
10-8-13	
REVISIONS	
DATE	CHANGE
07-08-14	Revised note 3.
10-17-17	Updated to active voice.
08-28-19	New Design Engineer PE Stamp.
11-01-24	Revised note 5.



COMBINATION FEED POINT DETAILS

D-770-2A

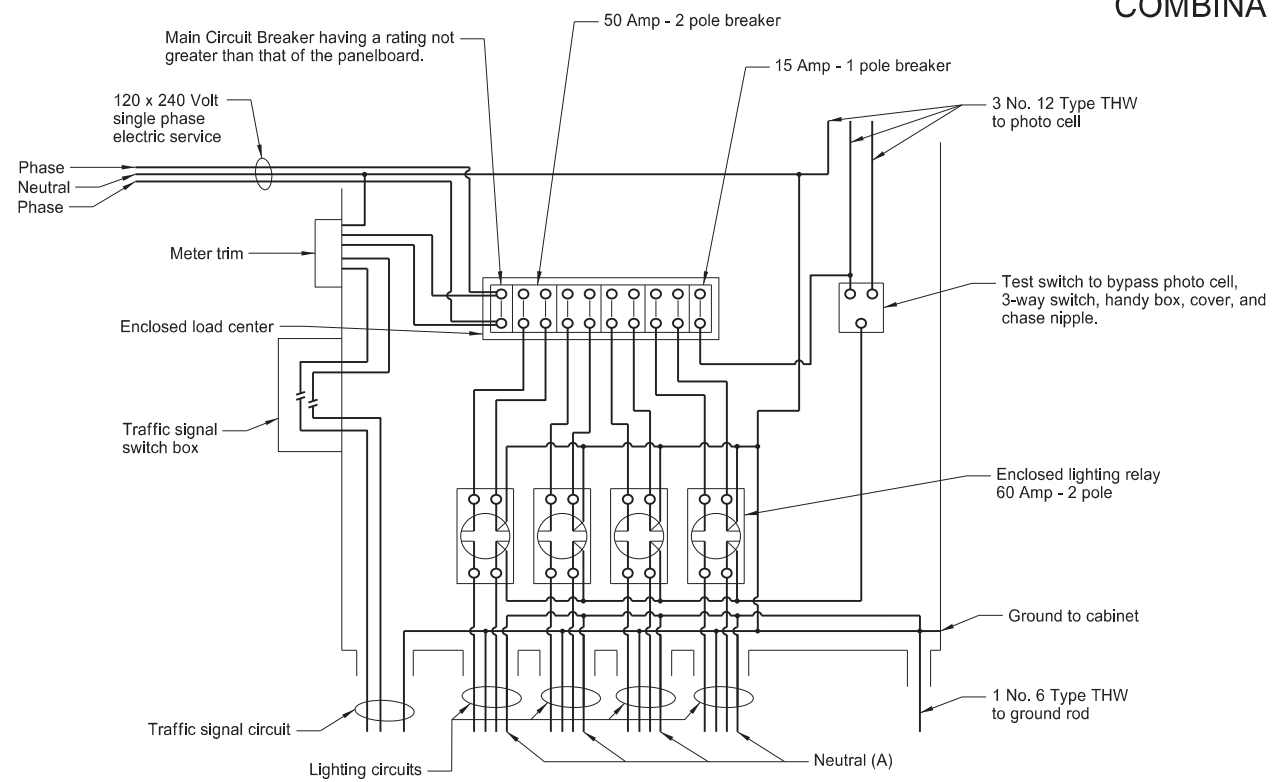

Combination Lighting and Signal Feed Point Type IV

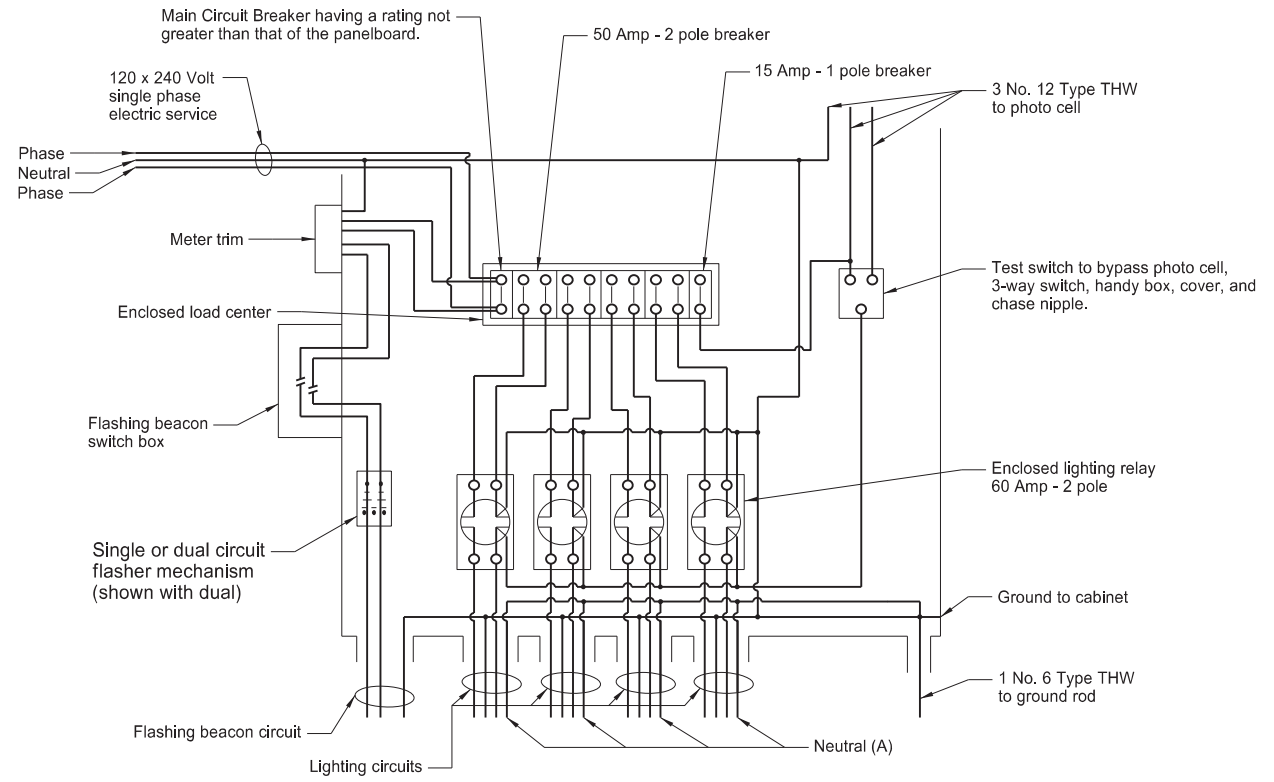

Combination Lighting and Flashing Beacon Feed Point Type IV

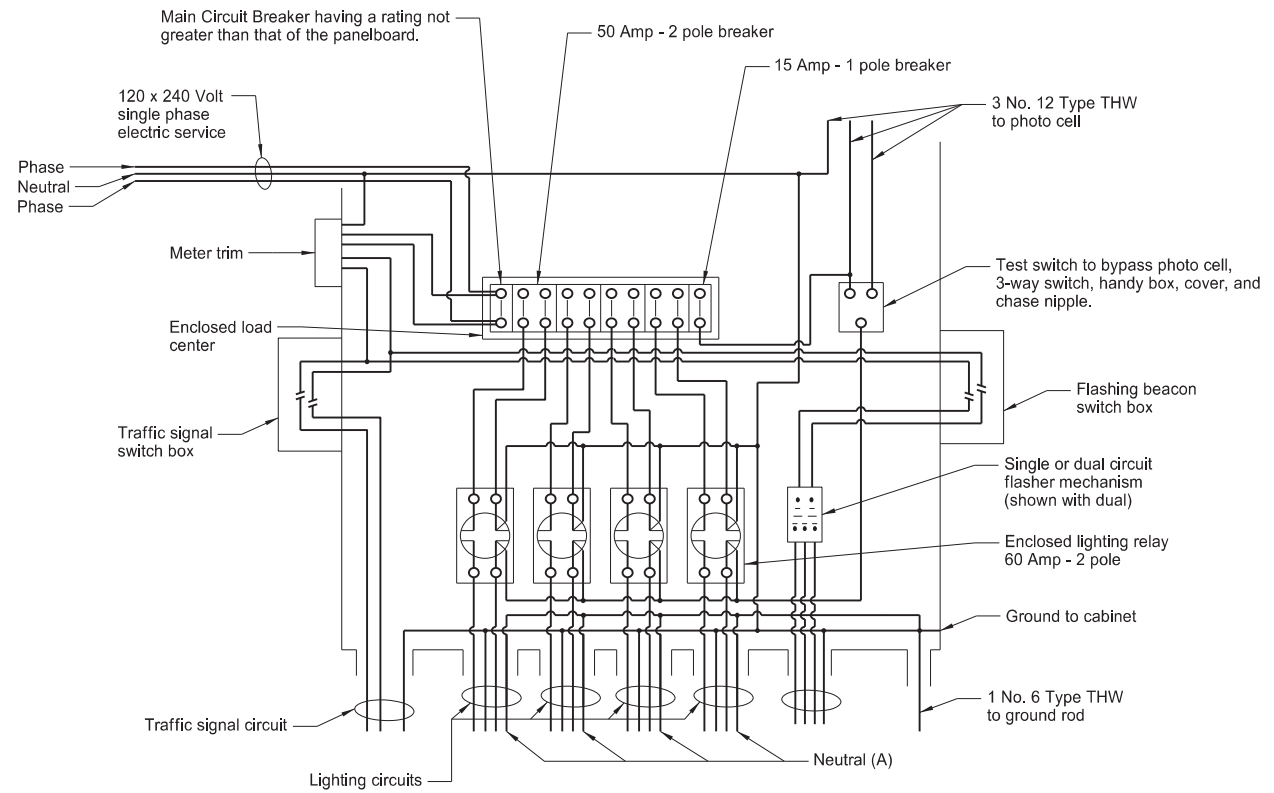

Combination Lighting, Signal, and Flashing Beacon Feed Point Type IV

Notes:
 Install Type I feed point similar to Type IV, except with one electrical circuit, one 50 Amp - 2 pole breaker, and one lighting relay, normally open.
 Install Type II feed point similar to Type IV, except with two electrical circuits, two 50 Amp - 2 pole breakers, and two lighting relays, normally open.
 Install Type III feed point similar to Type IV, except with three electrical circuits, three 50 Amp - 2 pole breakers, and three lighting relays, normally open.
 (A) Install when festoon circuits are required

NORTH DAKOTA DEPARTMENT OF TRANSPORTATION	
10-8-13	
REVISIONS	
DATE	CHANGE
10-17-17	Updated to active voice.
8-28-19	New Design Engineer PE Stamp.
8-09-24	Electronic Stamp/Signature.



08/09/24

PULL BOX & TRENCHING DETAILS

General Pull Box Notes:

1. Duct seal all conduits entering and exiting pull boxes.
2. Ensure all pull boxes are UL listed.

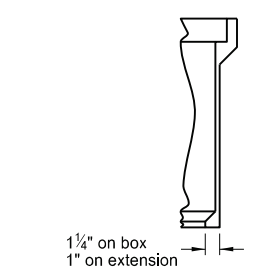
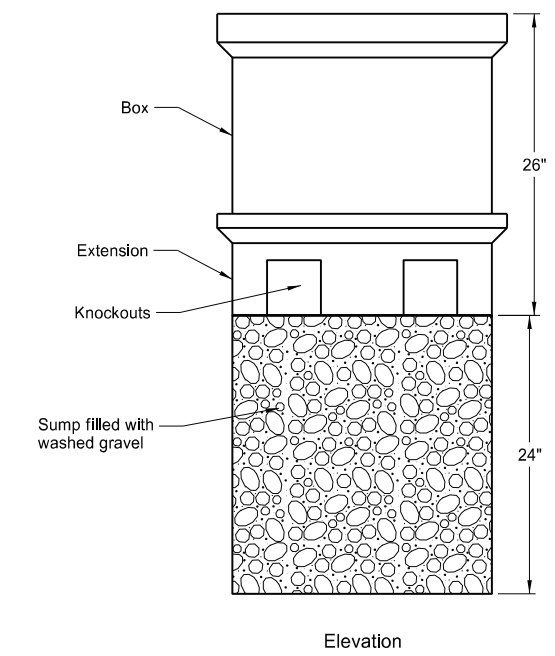
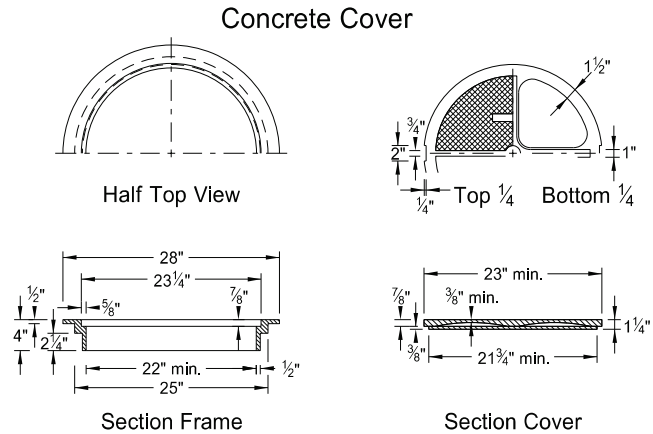
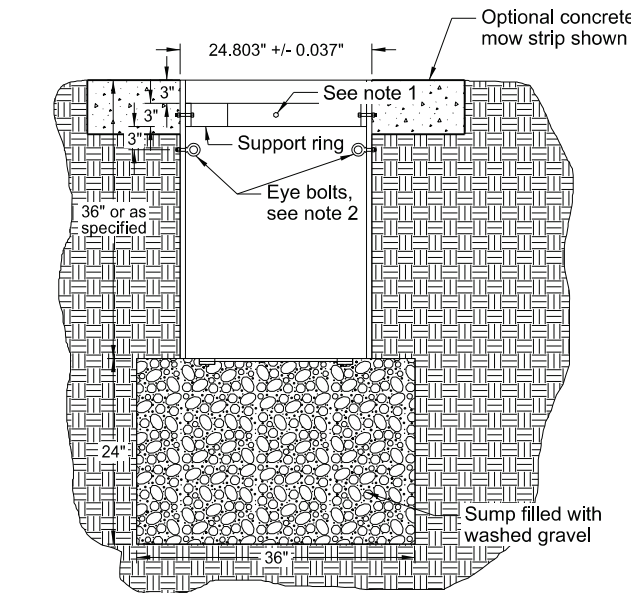
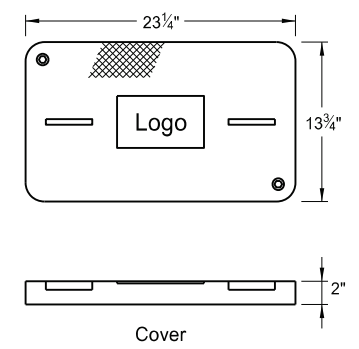
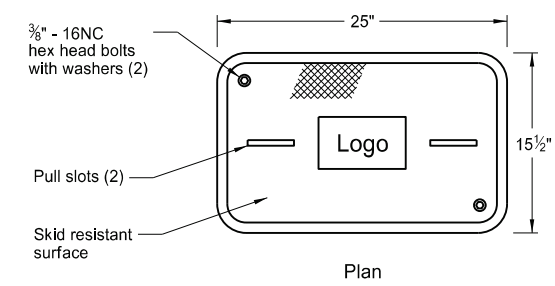
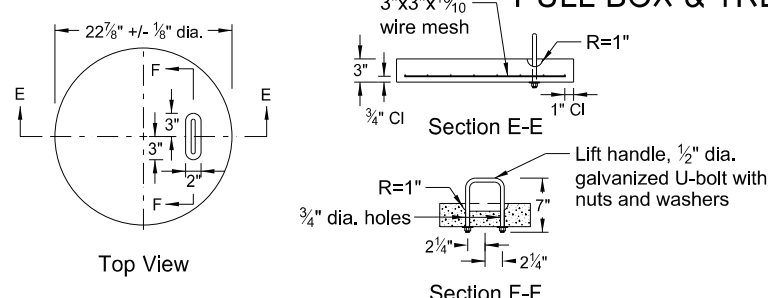
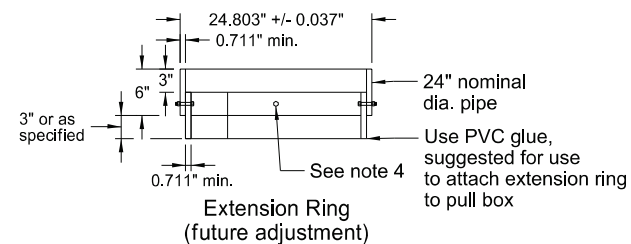

Polymer Concrete Pull Box Notes:

1. Place top of pull box flush with surfaced area and approximately one inch above earth or sodded areas on level surfaces.
2. Provide at least one knockout per side in pull box.
3. Provide Polymer Concrete pull box meeting Tier 22 as per ANSI / SCTE 77.
4. Ensure the pull box constructed of polymer concrete reinforced by a heavy weave fiberglass.

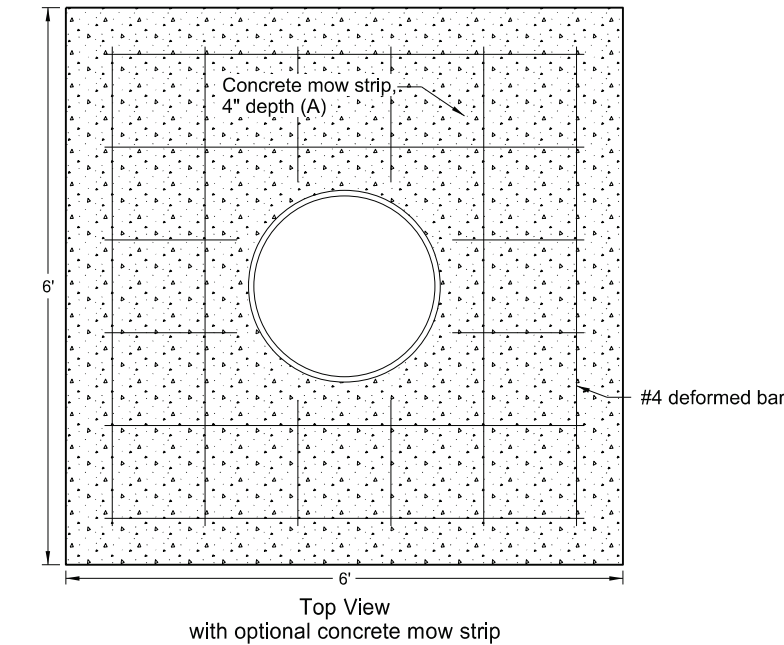
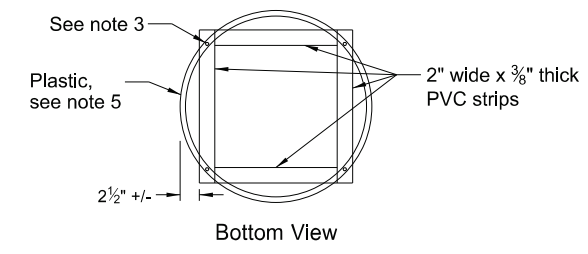

Polymer Concrete Pull Box

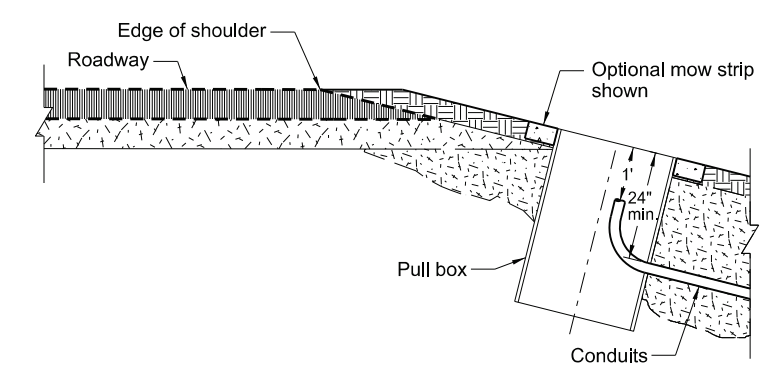

Pull Box Installation Details

PVC Pull Box Notes:

1. Attach split 24" nominal diameter PVC cover support ring with four 3/8" dia. x 2" long stainless steel hex head bolts with nuts at 90 degrees apart.
2. Two type 2 shoulder eye bolts, 3/8" dia. x 1 1/4" shank length with hex nuts 180 degrees apart (for lifting pull box and supporting electric cable).
3. Four 1/4" x 1 1/4" long galvanized lag screws. Screw assembly together.
4. Attach split 24" nominal diameter PVC cover support extension ring with four 3/8" dia. x 2" long stainless steel hex head bolts with nuts at 90 degrees apart.
5. Bolt assembly together.
6. Size conduit holes located in barrel section no more than 1" larger than size of conduit being used.
7. After pull box and conduit installation, install water tight seal for inside walls and cover.
8. PVC pipe to meet requirements of ASTM F679 or equal.
9. Provide Austenitic Stainless Steel Hex Head bolts and nuts. Other fasteners to be galvanized as per ASTM A153.
10. Install an epoxy coating on the top and sides of the concrete cover. Provide an epoxy protective coating that is light gray, clear, or neutral in color and apply as recommended by the pull box manufacturer. Before application, clean with a wire brush and dry the surfaces of the concrete to which the epoxy protective coating is applied.
11. If a Cast Iron cover is provided, use grey iron as per AASHTO M 306.

Note: The location of pull box will vary, refer to layout sheets for actual location.

When required, install a mow strip around the pull box. Place expansion material between the foundation and the mow strip. Ensure the mow strip is 4" depth and 2' width from the foundation. Use #4 deformed bars in the mow strip. Space the bars 6" from the outside edge. Place the bars in a grid pattern at 1' apart.

NORTH DAKOTA DEPARTMENT OF TRANSPORTATION	
10-8-13	
REVISIONS	
DATE	CHANGE
11-01-24	Updated PVC pull box, trenching.

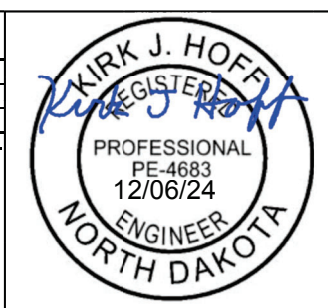

LIGHTING AND SIGNAL DETAILS

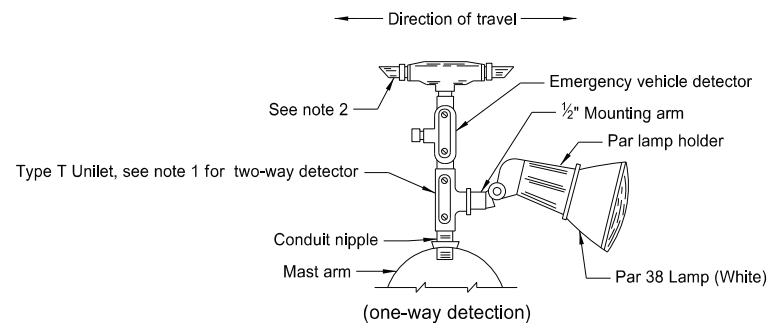

Emergency Vehicle Detector Detail

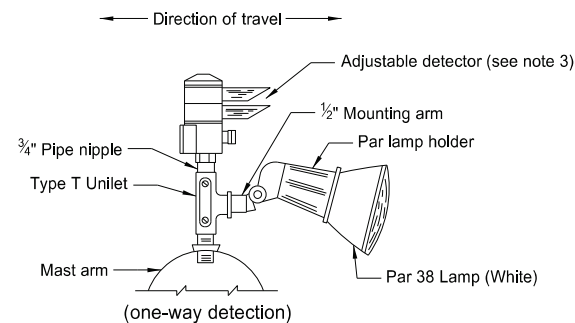

Alternate Emergency Vehicle Detector Detail (adjustable)

- Notes:
 1. Use Type X Unilet with two Par lamp holders and lamps for Two-way Detectors. (one in each direction).
 2. Plug unused end of One-way Detector with metal pipe plug.
 3. Rotate detector lens to face direction of travel on Two-way Detectors.

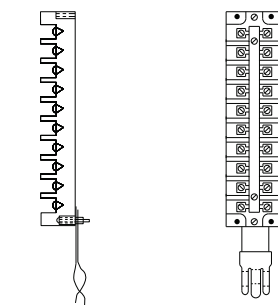

Terminal Block Detail

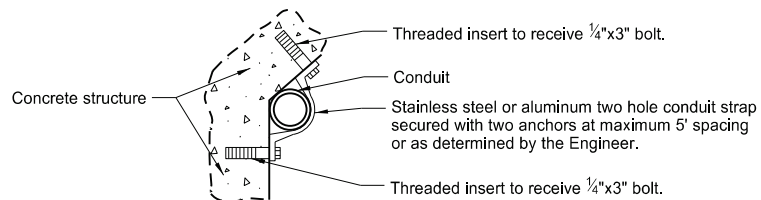

Bridge Mounted Conduit Hanger

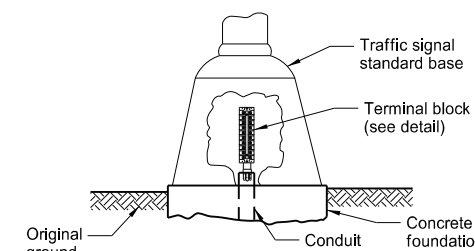

Terminal Block (rigid mounted)

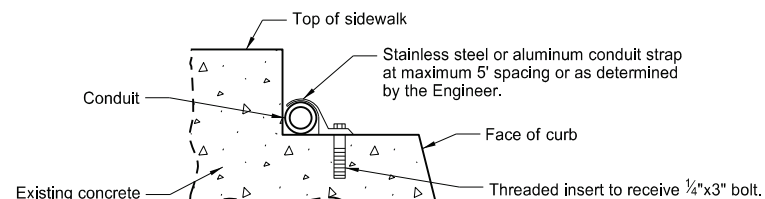

Bridge Curb Mounted Conduit

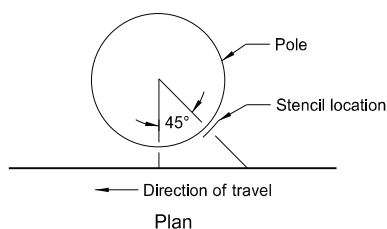

Light Standard Numbering

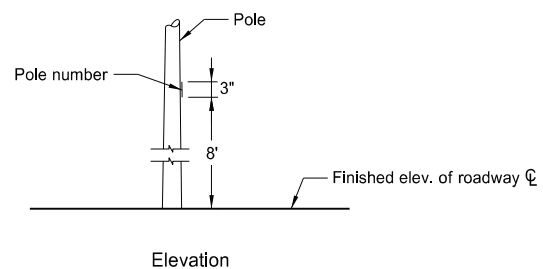

Note: On the roadway side of each light standard, stencil the pole number using contrasting color paint or an adhesive coated plastic such as Scotchlcal by 3M or as approved by the Engineer. See layout sheets for pole numbers.

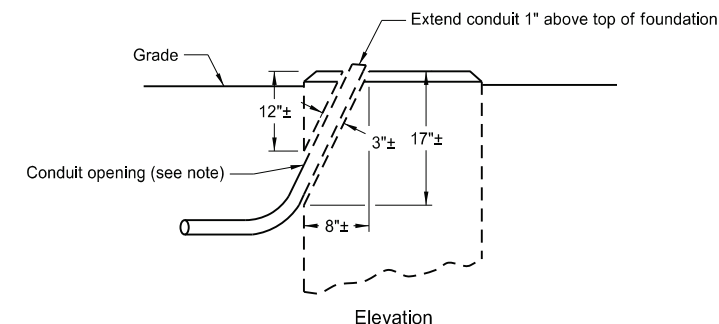

Revise Concrete Foundation

Note: Jackhammer or drill to remove material and provide a location for conduit. Make opening no larger than necessary. Place conduit, fill with concrete and finish foundation to original appearance.

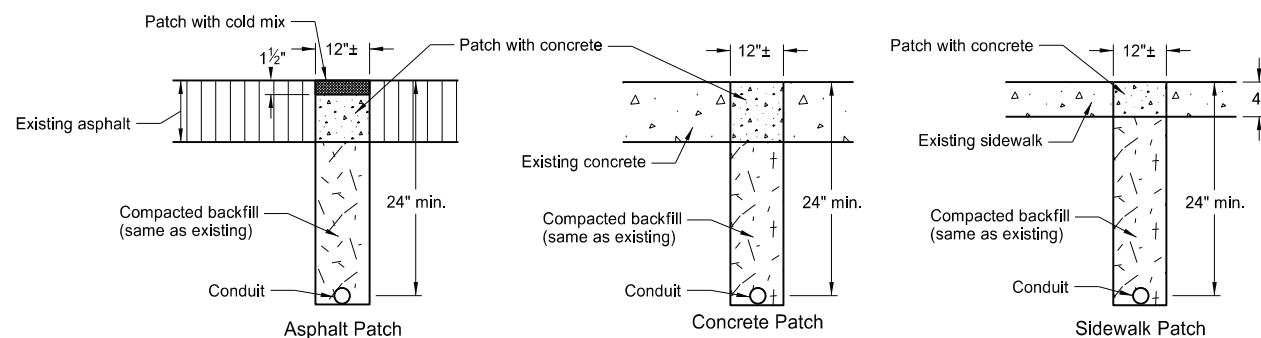

Surface Patch Details

Note: Saw cut trenches. Use PCC pavement for replacement concrete with the coarse aggregate gradation, maximum size and method of curing as approved by the Engineer. Immediately prior to pouring replacement concrete, paint all surfaces with an approved epoxy compound.

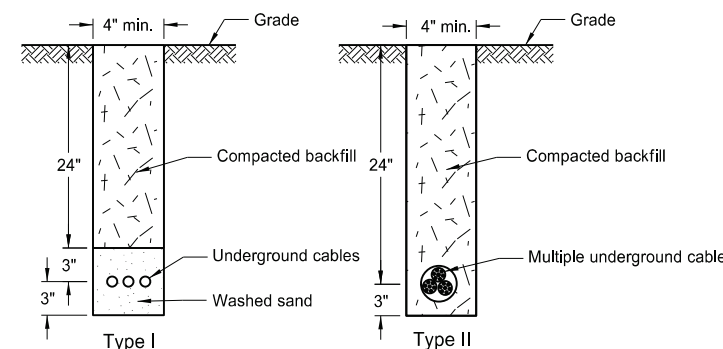

Cable Trench

Note: Seed entire area disturbed by trenching.

NORTH DAKOTA DEPARTMENT OF TRANSPORTATION	
10-8-13	
REVISIONS	
DATE	CHANGE
10-17-17	Updated to active voice.
10-25-19	Removed conduit under RR detail.
11-01-24	Updated bridge hanger detail.

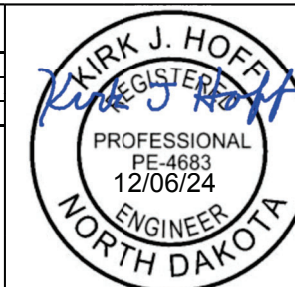

LIGHT STANDARD DETAILS

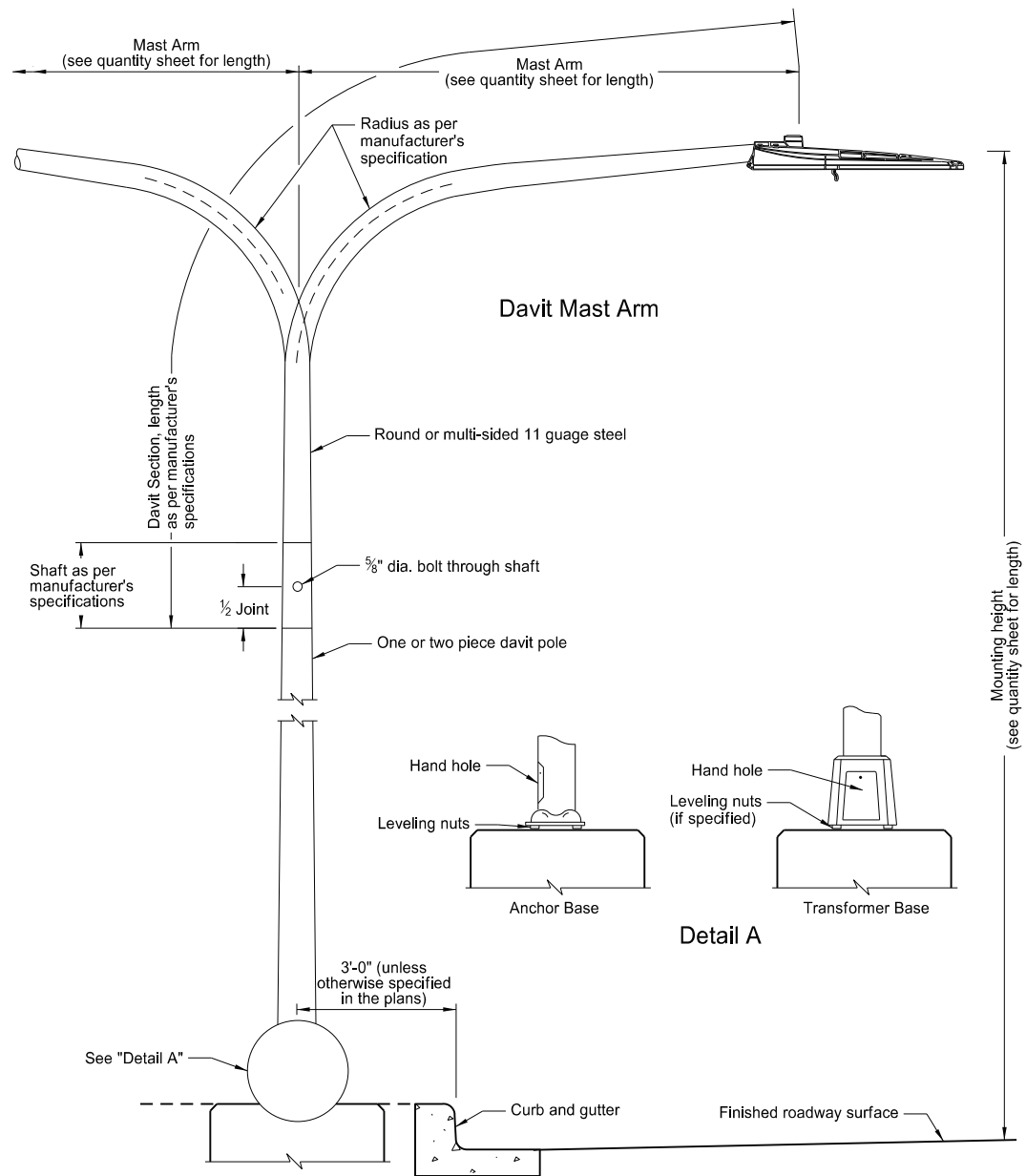

Light Standard Details

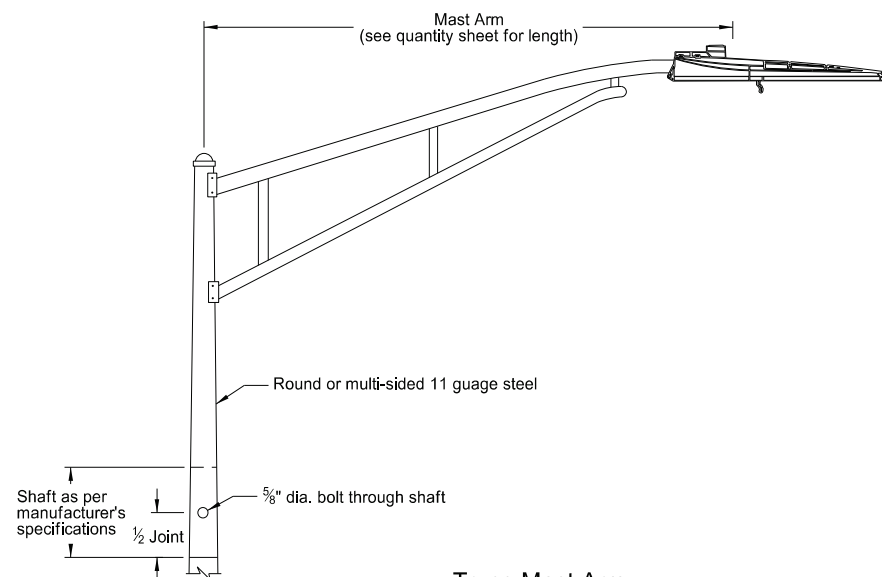

Truss Mast Arm

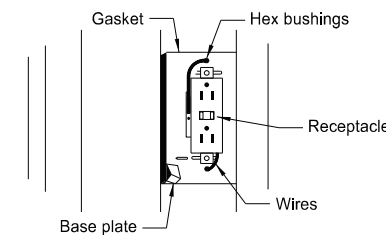

Optional: Festoon receptacle mounted on multi-sided pole.

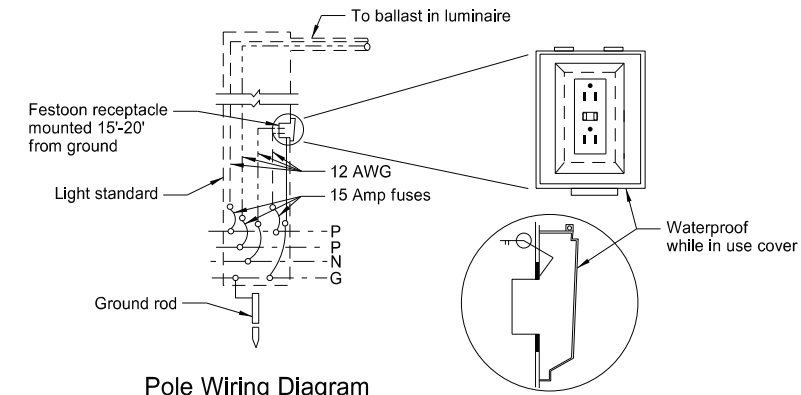

Pole Wiring Diagram

Receptacle Mounting Detail (B)

(B) Mount receptacle on side of pole that faces the street. Install Festoon Receptacle only when specified in the plans.

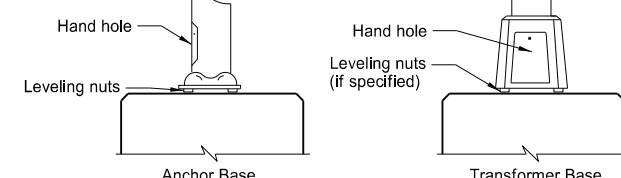

Detail A

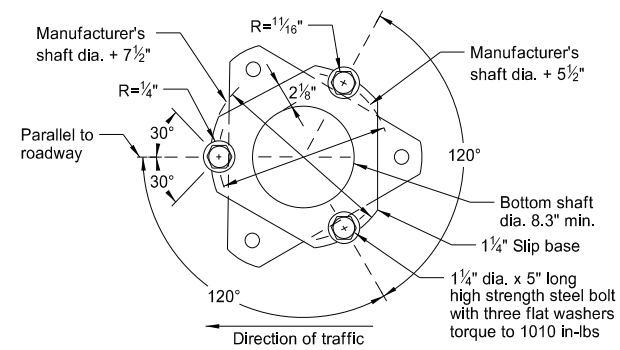

Top View

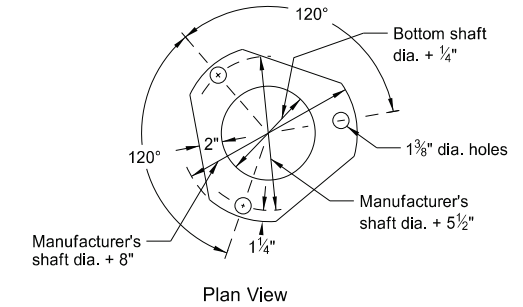

Plan View

Keeper Plate Detail (A)

(A) ASTM A446 Grade "A" 28 gauge keeper plate on top of middle flat washer. Galvanize Keeper plate after fabrication.

Notes:

Light Standard Locations: The minimum offset distance from the curb face is 3 feet. Offset light standards at least 3 feet in urban areas and where speeds are less than 30 mph. Where speeds are 30 mph or more, place light standards at least 16 feet from the driving lane.

Steel Standards: Touch up marred or scratched areas after erection.

Luminaire: Use internal ballast-constant wattage 120x240 voltage. See layout sheets for type of luminaire, wattage, I.E.S. distribution, and operating system.

Fusing: Fusing in base, see specifications.

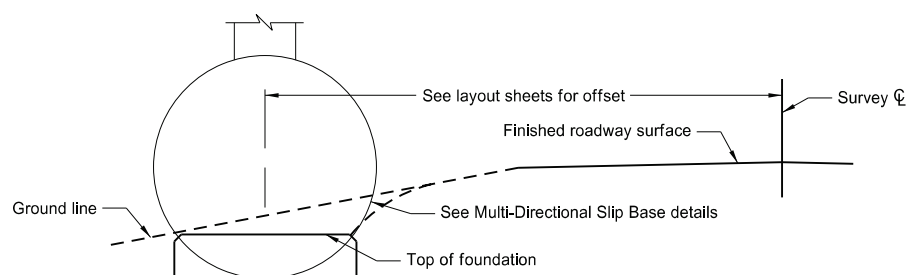

Concrete Foundation Location

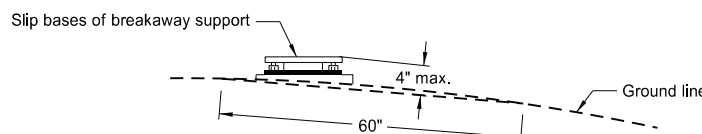

Breakaway Support Stub Clearance Diagram

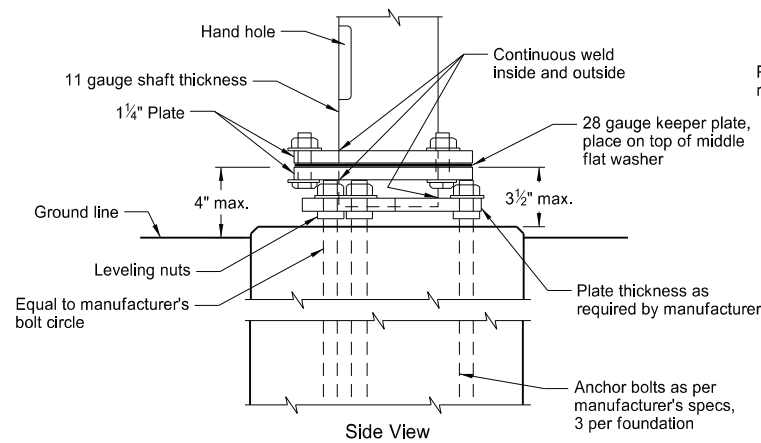

Steel Base Detail

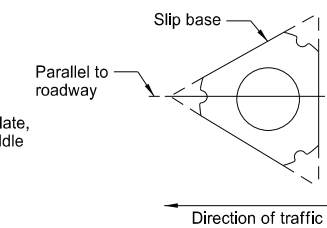

Slip Base Placement Detail

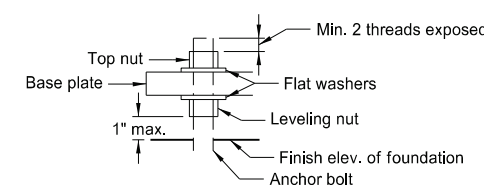

Anchor Bolt Detail

Multi-Directional Slip Base

NORTH DAKOTA DEPARTMENT OF TRANSPORTATION	
10-8-13	
REVISIONS	
DATE	CHANGE
10-17-17 08-28-19 11-01-24	Updated to active voice. New Design Engineer PE Stamp. Revised luminaire details/notes.

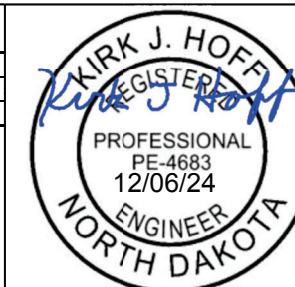

TRAFFIC SIGNAL STANDARDS

D-772-2

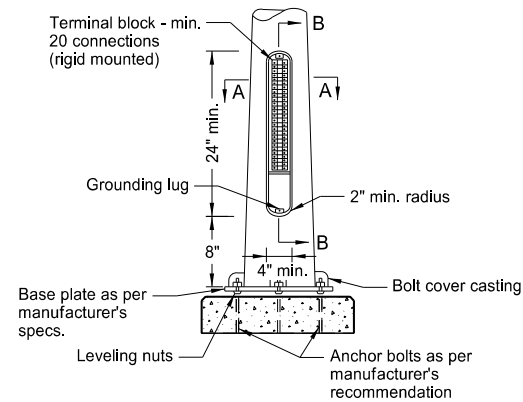
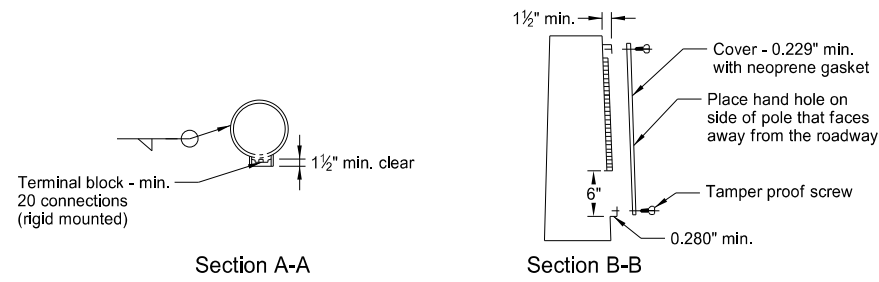

Alternate Signal Standard Base
For use only with Type V, VI, and VII signal standards.

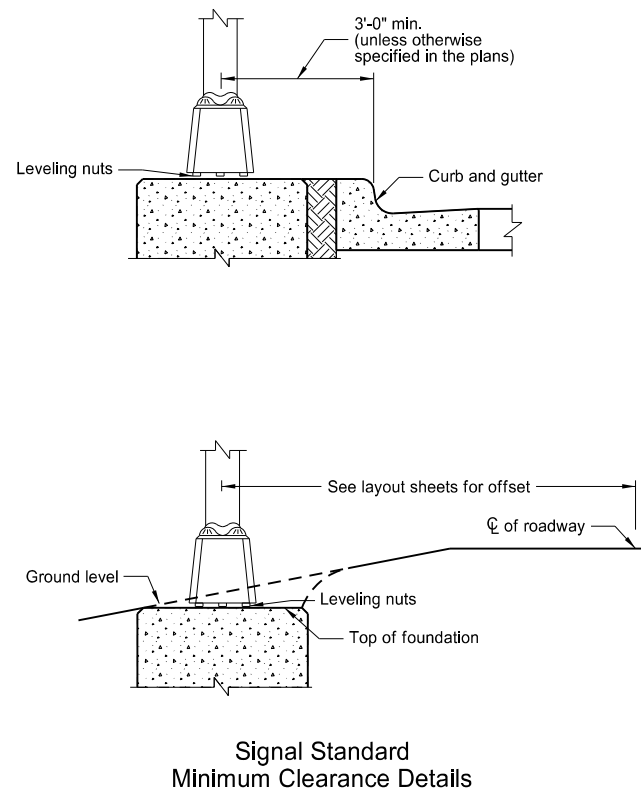
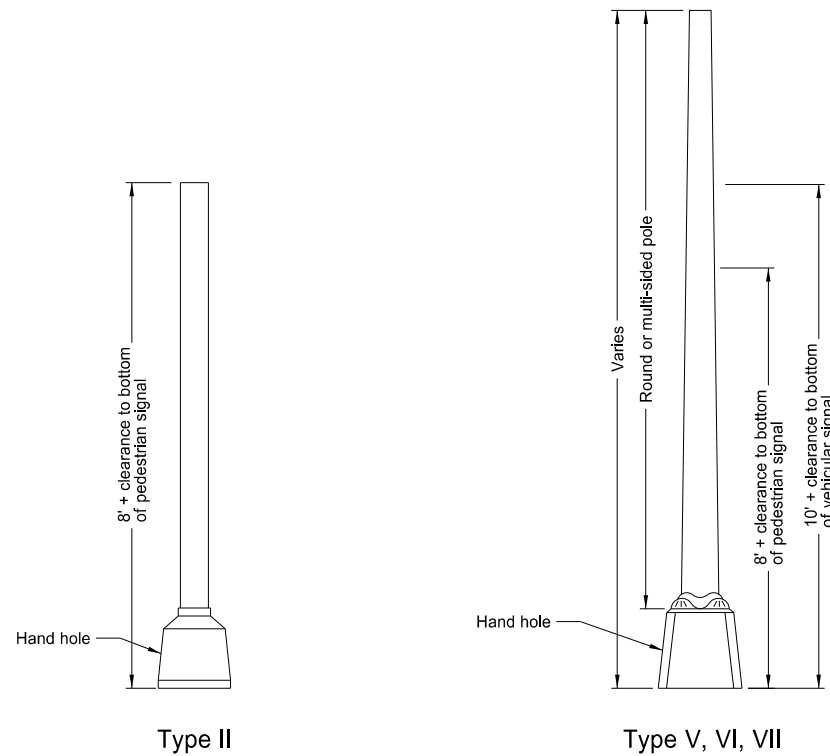
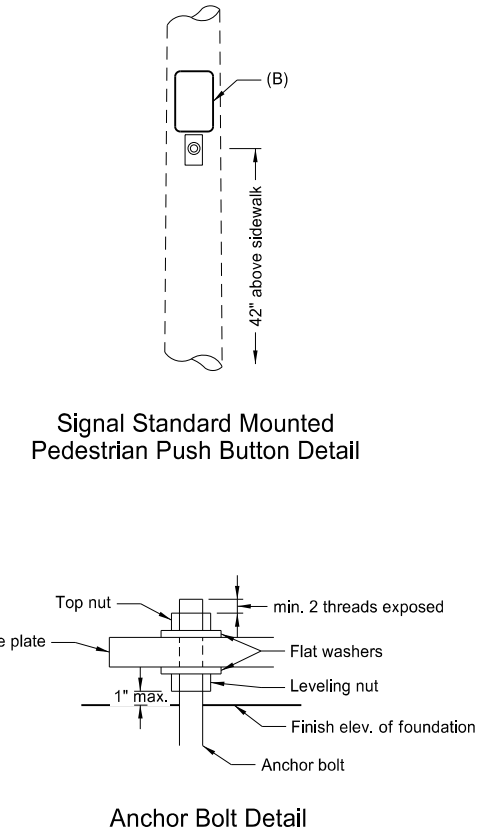
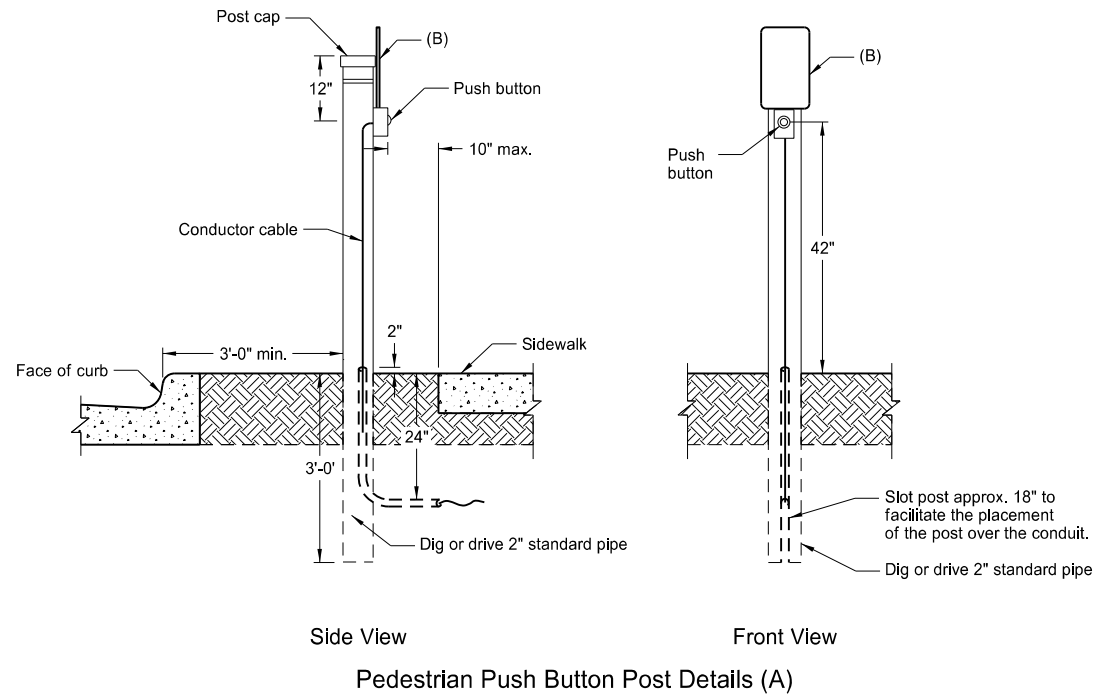

- (A) Use positioning of the sign, pushbutton, and direction of arrow to clearly indicate which crosswalk is actuated by the push button. Place type of sign based on the jurisdiction in which placed.
- (B) Attach sign to post using rust resistant 0.081 aluminum bracket and banding. See Standard Signs book for dimensions and legend series. See plans for type of sign.

Notes:

- Signal Heads: See traffic signal layout for correct mounting position, number, size, and arrangement of lenses.
- Steel Standards: Place signal standard a minimum of 3 ft. from the face of the curb to center of signal standard, unless shown otherwise on layout sheets.
- Paint: See note sheet for required color of paint.
- Transformer Base: In lieu of transformer base use alternate signal standard base.

NORTH DAKOTA DEPARTMENT OF TRANSPORTATION	
11-14-13	
REVISIONS	
DATE	CHANGE
10-17-17	Updated to active voice.
10-25-19	Added 10" dim for ped pushbutton.

This document was originally issued and sealed by
Kirk J Hoff,
Registration Number
PE- 4683,
on 10/25/19 and the original document is stored at the North Dakota Department of Transportation

TRAFFIC SIGNAL STANDARDS (MAST ARM TYPE)

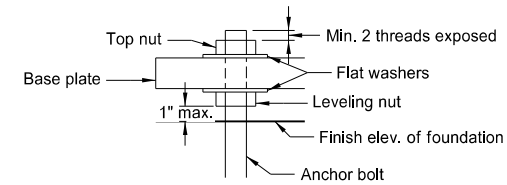

Anchor Bolt Detail

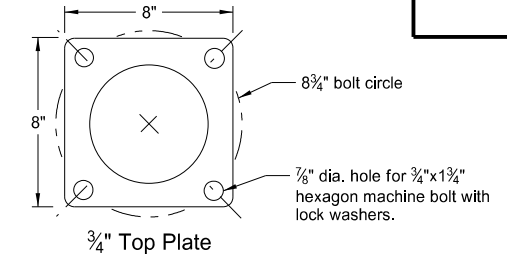

3/4" Top Plate

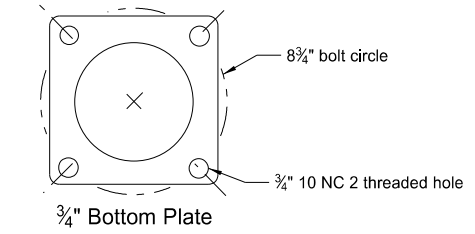

3/4" Bottom Plate

Detail A

Note: In lieu of the plate type connection, use a telescoping clamp type extension.

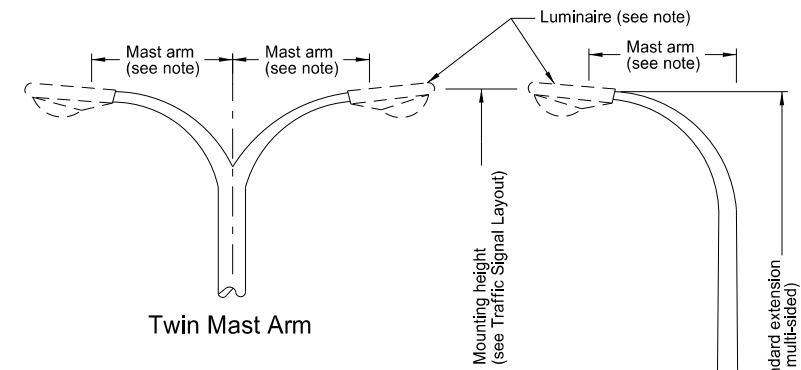

Twin Mast Arm

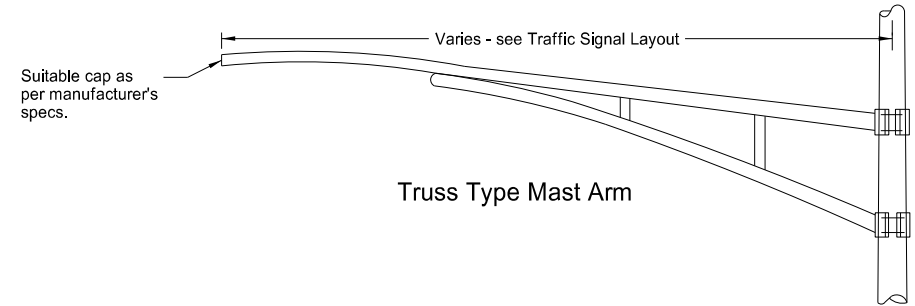

Truss Type Mast Arm

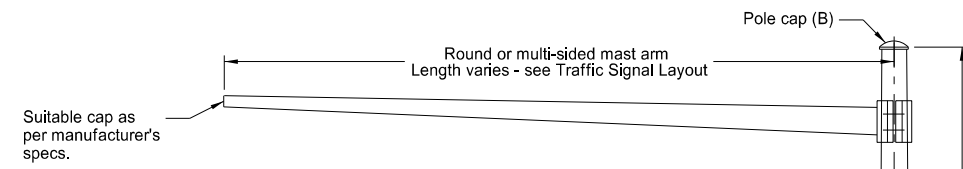
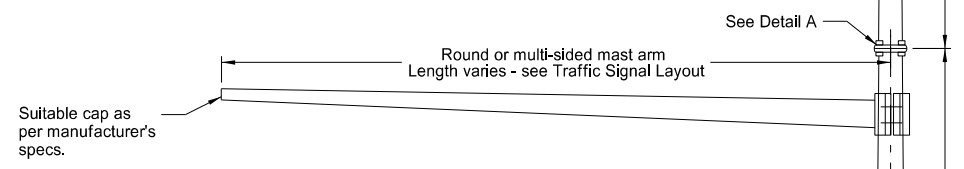

Combination Signal and Light Standard			
Signal Standard Type	Luminaire Mounting height (ft)	Install Light Standard Extension and Luminaire	Luminaire Mast Arm
A	30	yes	single
B	30	(A)	single
C	40	yes	single
D	40	(A)	single
E	30	yes	twin
F	30	(A)	twin
G	40	yes	twin
H	40	(A)	twin
I	50	yes	single
J	50	yes	twin

(A) Install the light standard extension for these signal standards at a later date under a separate contract.

Notes:

- Light standard extension: Mast arm is 6 ft. unless otherwise noted on the plans. Use light standard extension galvanized in accordance with ASTM A 123.
- Luminaire: Use internal ballast - constant wattage 120 x 240 voltage luminaires. See layout sheets for type of luminaire, wattage, and I.E.S. distribution.
- Signal head: See Traffic Signal Layout for correct mounting position, number, size, and arrangement of lenses. Place mast arm mounted signal heads with a clearance between 17 ft. and 19 ft. from the centerline of the roadway to the bottom of signal heads.
- Multi-sided poles: Provide a means, other than friction, that will not allow the mast arm to be rotated by wind forces. Fabricate the pole so the mast arm is rotatable. This feature to be as approved by the Engineer.
- Transformer base: In lieu of the transformer base, use the alternate signal standard base.

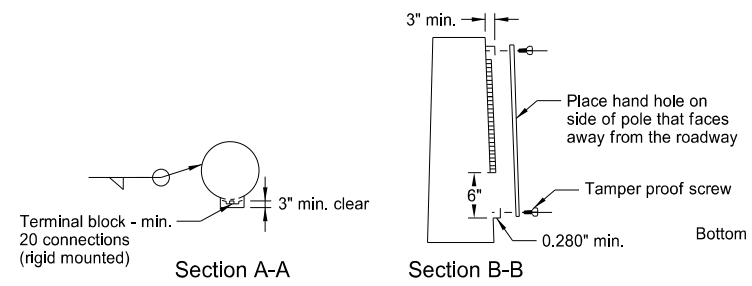

Section A-A

Section B-B

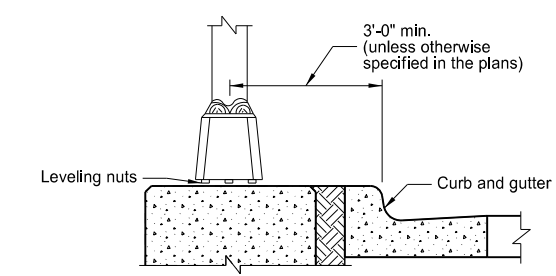

Signal Standard Minimum Clearance Detail

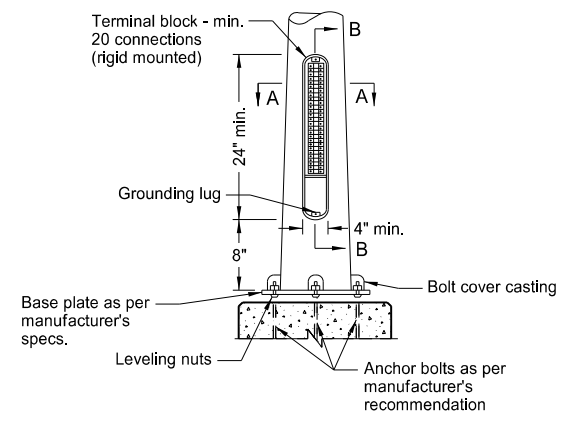

Alternate Signal Standard Base

Note: For use with Type IV and combination signal standards only

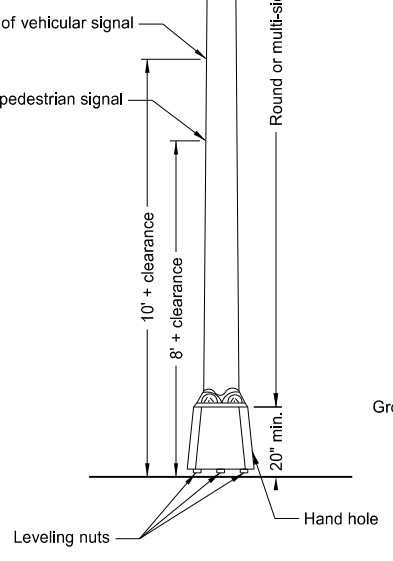

Combination Signal and Light Standard

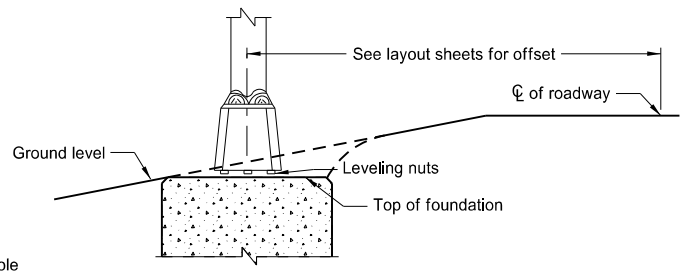

(B) On combination signal and light standards Type B, D, F, and H, and on all Type IV signal standards install a suitable pole cap as per manufacturer's specifications.

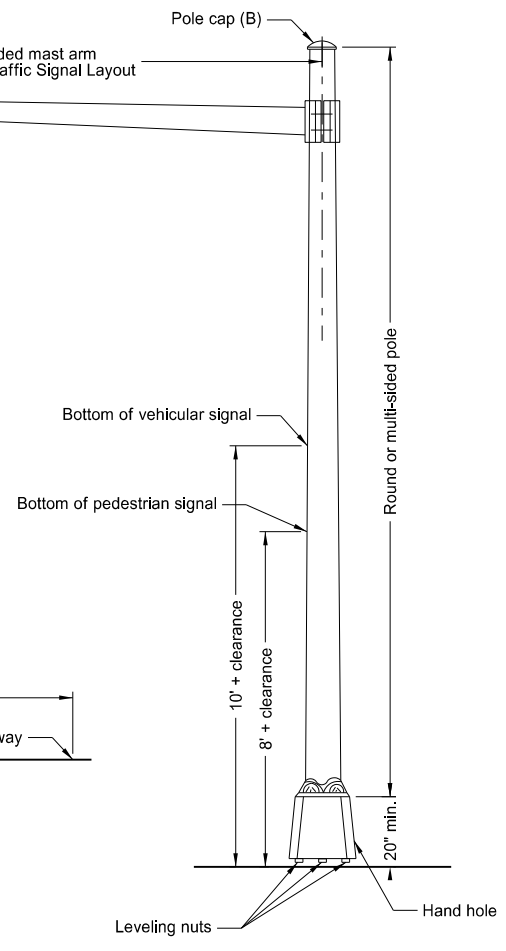

Type IV Signal Standard

NORTH DAKOTA DEPARTMENT OF TRANSPORTATION	
11-14-13	
REVISIONS	
DATE	CHANGE
10-17-17 08-28-19	Updated to active voice. New Design Engineer PE Stamp.

This document was originally issued and sealed by
Kirk J Hoff,
Registration Number
PE- 4683,
on 8/28/19 and the original document is stored at the
North Dakota Department
of Transportation

TRAFFIC SIGNAL HEAD MOUNTING

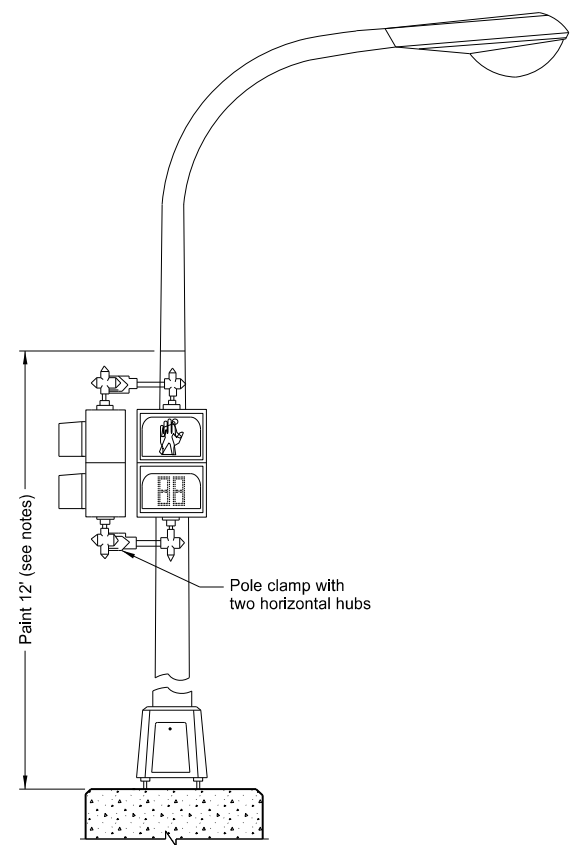

Light Standard Mounted Pedestrian Signal Head (A)



Pedestrian countdown timer
(A) See plans for the appropriate orientation and type of pedestrian signal head to use.

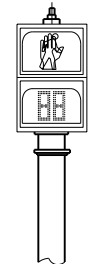

Type II
Pedestal Mounted - Pedestrian (A)

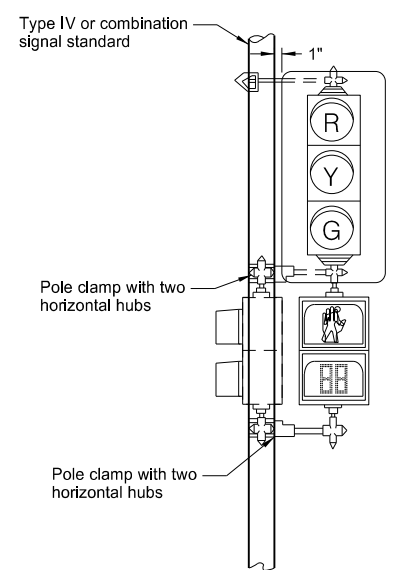

Type IV
Post Mounted - Vehicular
Post Mounted - Pedestrian (A)

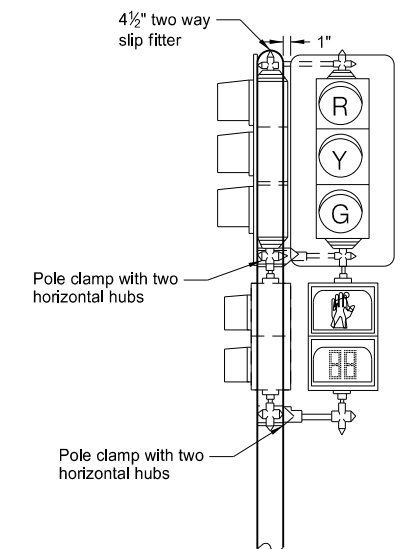

Type V
Post Mounted - Vehicular
Post Mounted - Pedestrian (A)

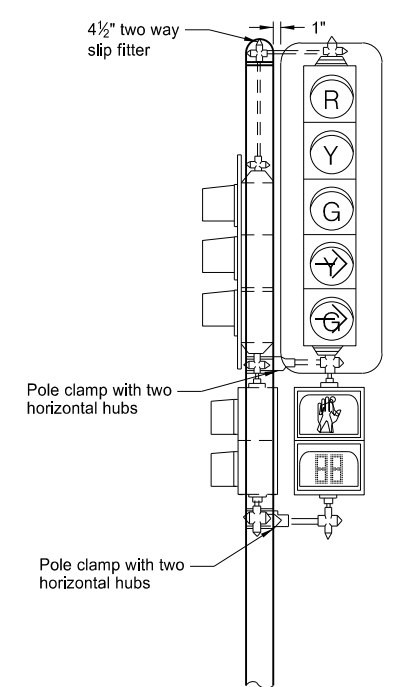

Type VI
Post Mounted - Vehicular
Post Mounted - Pedestrian (A)

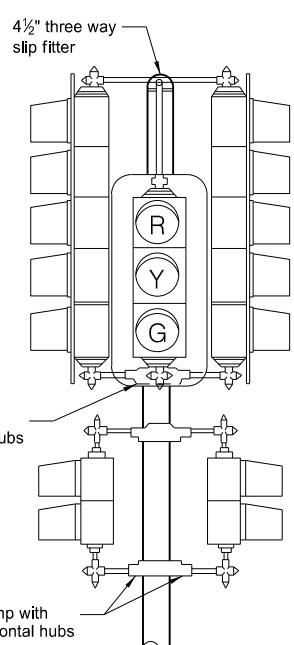

Type VII
Post Mounted - Vehicular
Post Mounted - Pedestrian (A)

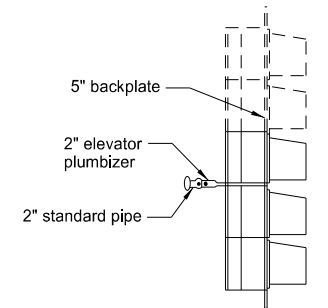

Side View
Mid-Span Mounted and Mast Arm Rigid Mounted Signal Heads

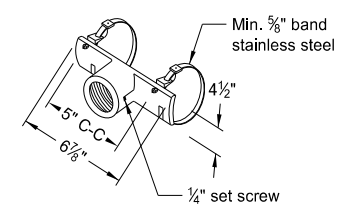

Mast Arm Signal Head Bracket

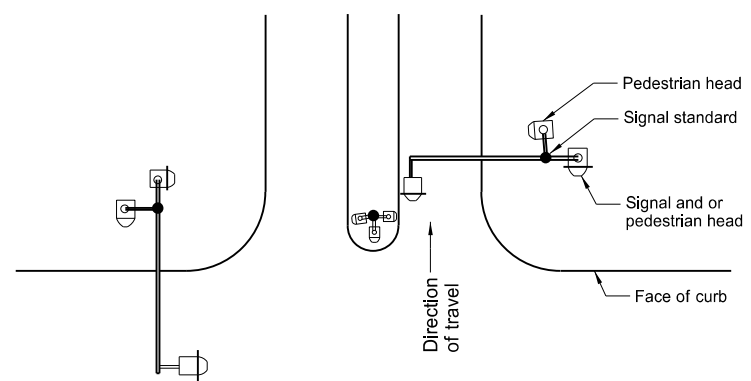

Note: Place signal heads behind the face of the curb.

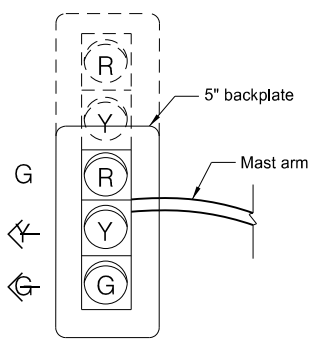

Front View

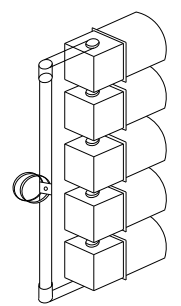

Isometric View

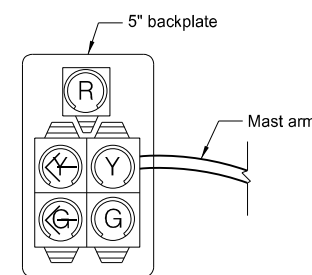

Front View

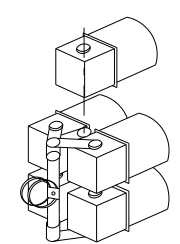

Isometric View

End Mounted and Mast Arm Rigid Mounted Signal Heads

Notes:

- Reinforcing Plates:** Install reinforcing plates where mounting hardware attaches to signal heads when using polycarbonate signal heads. Where a plumbizer is used, place reinforcing plates on each side of the plumbizer.
- Clearance:** Place the bottom of post or pedestal mounted vehicular signal heads a minimum of 10 ft. and pedestrian signal heads a minimum of 8 ft. above the ground line or sidewalk.
- Signal Heads:** See traffic signal layout for correct mounting position, numbers, size, and arrangement of lenses.
- Pole Clamps:** A pole plate with suitable banding material, as approved by the Engineer, is allowed in place of pole clamps. Where traffic signal heads and pedestrian signal heads are mounted one above the other, one pole clamp assembly is allowed.
- Paint:** Paint signal housing yellow and backplates dull black. Paint pole clamps and signal head mounting hardware the same color as the signal standard shaft.
- When pedestrian heads are light standard mounted, paint the lower 12 ft. the same color as the other traffic signal standards.
- Mounting Details:** All signal heads shown viewed from direction of travel.

NORTH DAKOTA DEPARTMENT OF TRANSPORTATION	
11-14-13	
REVISIONS	
DATE	CHANGE
7-8-14	Added reinforcing plate note
10-17-17	Updated to active voice.
8-28-19	New Design Engineer PE Stamp.

This document was originally issued and sealed by
Kirk J Hoff,
Registration Number
PE-4683,
on 8/28/19 and the original document is stored at the North Dakota Department of Transportation

LOOP DETECTOR DETAILS
(SAW SLOT)

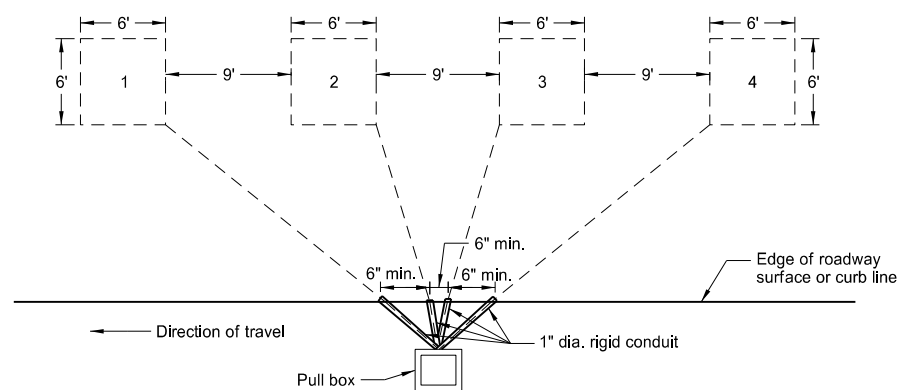

Multiple Loop Details
(Presence Loops)

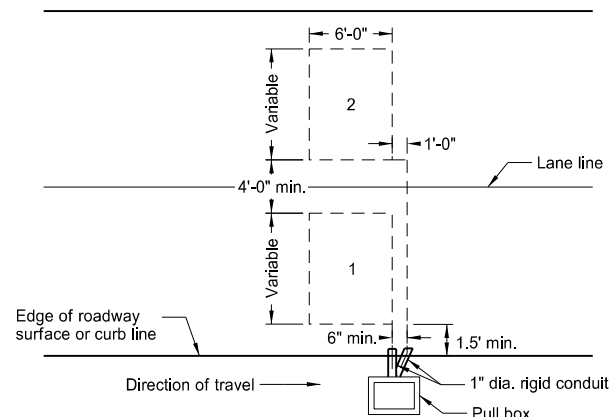

Loop Detector Detail
(Passage or Calling Loops)
Number of loops and number of turns as shown in the plans

Notes:

1. Saw cut each loop in roadway.
2. The number of turns, size of loop, and size of conductor shown on the plans.
3. Place leads from the loop to the pull box in saw slots and conduits to minimize interaction.

- (A) 1" minimum on concrete surface
2" minimum on asphalt surface

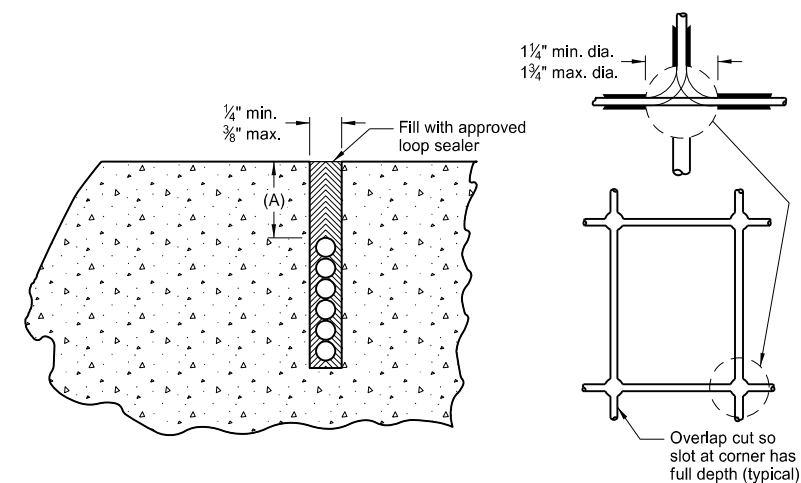

Saw Slot Details

Drill detector loop corners 2" deep then saw pavement slots to form loops. Dimensions and location shown in plans.

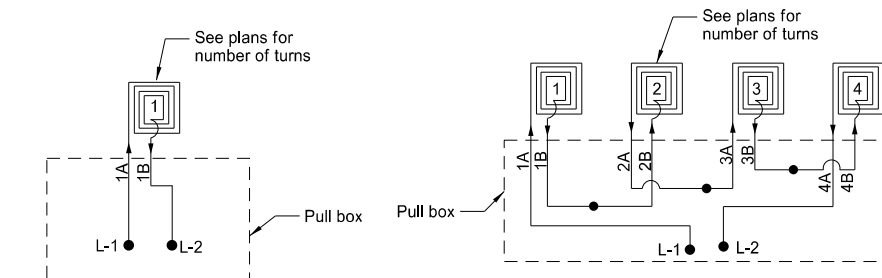

Single Loop Connection

Label all conductors in the pull box as shown. Splice loop connections in the pull box.

Multiple Loop Connection

Where multiple loops are connected to create one detection zone, label all conductors in the pull box as shown and splice loop connections in the pull box as shown. Number of loops varies with connections made following the same pattern.

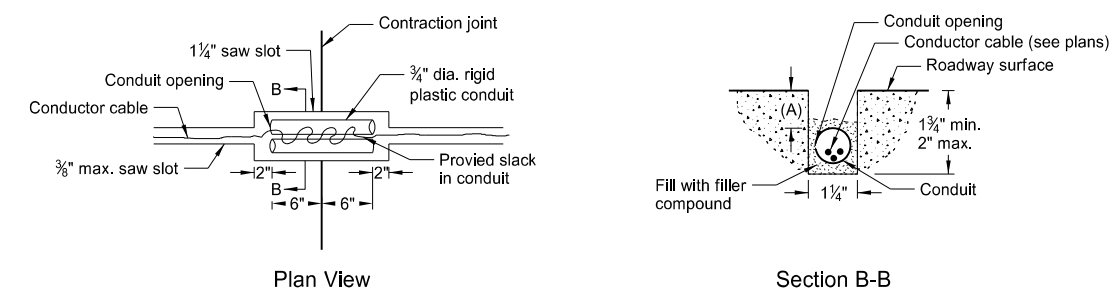

Construction Joint Detail

Use Construction Joint Detail when a crack in the roadway is encountered.

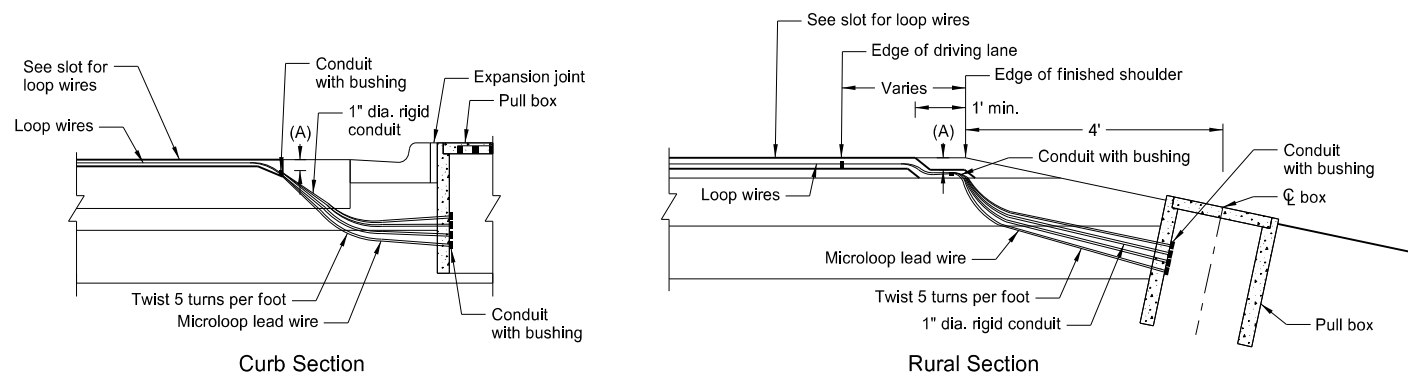

Saw Slot to Pull Box Details

NORTH DAKOTA DEPARTMENT OF TRANSPORTATION	
11-14-13	
REVISIONS	
DATE	CHANGE
10-17-17 08-28-19	Updated to active voice. New Design Engineer PE Stamp.

This document was originally issued and sealed by
Kirk J Hoff,
Registration Number
PE- 4683,
on 8/28/19 and the original document is stored at the North Dakota Department of Transportation

LOOP DETAILS

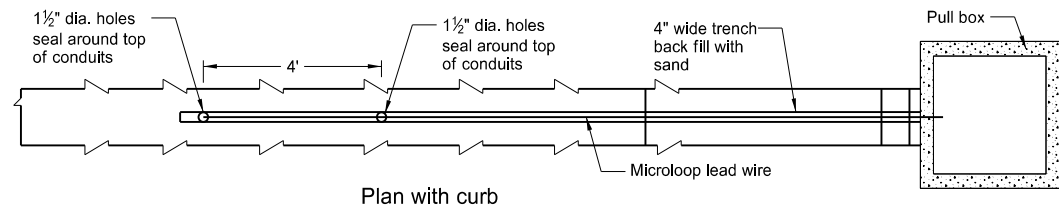

Plan with curb

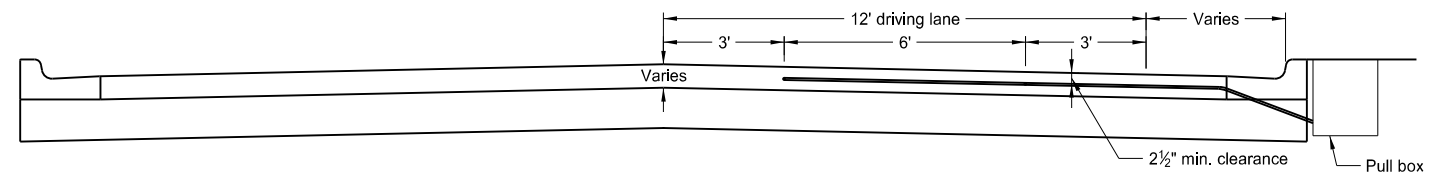

Elevation
Preformed Loop Detector Layout

Installation of Preformed Loop detector when placed in new pavement.

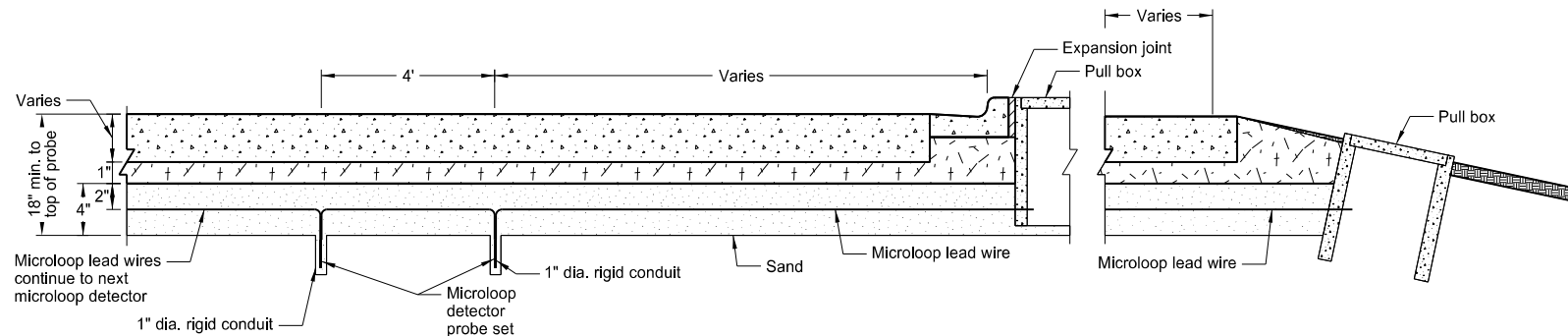

Elevation with curb

Elevation without curb

Microloop Placement in New Pavement

Notes:

After the installation and compaction of the aggregate base, trench a 4 in. trench and drill the 1 1/2 in. dia. holes. Embed microloop detectors in the sand as shown. Recompact aggregate base to the density of surrounding material and test microloops prior to placing PCC pavement.

Drill 1 1/2 in. dia. holes a minimum of 2 in. below bottom of microloop detector probe.

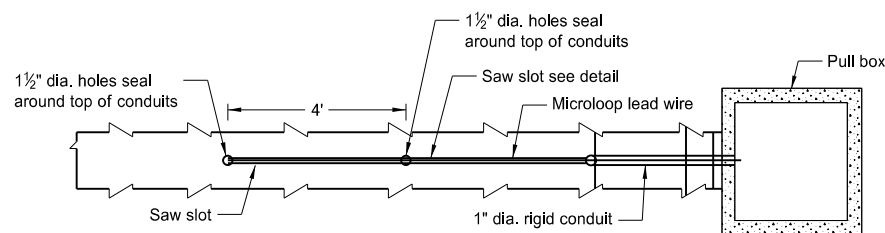

Plan with curb

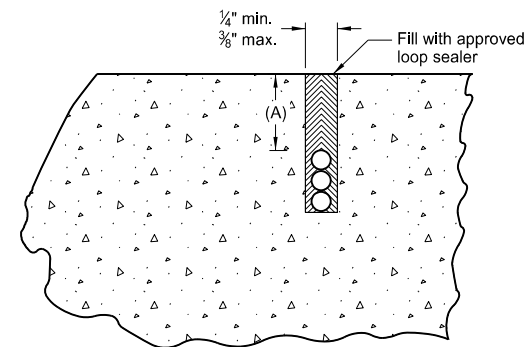

Saw Slot Details

(A) 1" minimum on concrete surface
2" minimum on asphalt surface

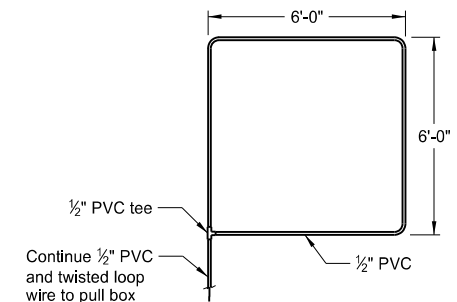

Preformed Loop Detector Layout

Securely tie down Preformed Loop to prevent loop from floating while placing concrete.

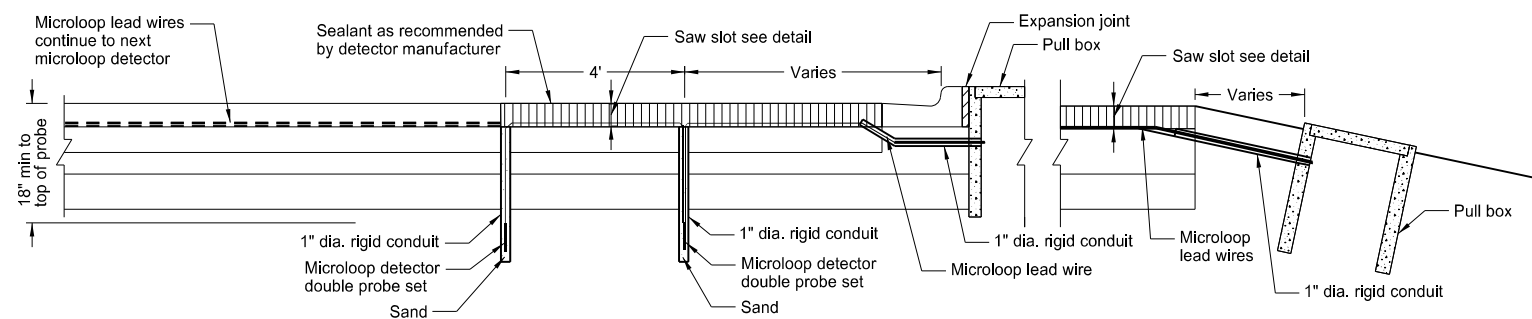

Elevation with curb

Elevation without curb

Microloop Placement in Existing Pavement

Notes:

Drill 1 1/2 in. dia. holes, cut saw slot in the pavement, install 1 in. conduit, and install microloop detectors so tops of probes are 15 in. below road surface. Fill 1 in. dia. conduit with sand, seal saw slot, and test microloops.

Drill 1 1/2 in. dia. holes a minimum of 2 in. below bottom of microloop detector probe.

NORTH DAKOTA DEPARTMENT OF TRANSPORTATION	
11-14-13	
REVISIONS	
DATE	CHANGE
10-17-17 08-28-19	Updated to active voice. New Design Engineer PE Stamp.

This document was originally issued and sealed by
Kirk J Hoff,
Registration Number
PE- 4683,
on 8/28/19 and the original document is stored at the North Dakota Department of Transportation