

DESIGN DATA			
Traffic	Average Daily		
Current 2024	Pass: -	Trucks: -	Total: 26,650
Forecast 2050	Pass: -	Trucks: -	Total: 29,000
Clear Zone Distance: 14'		Design Speed: 30 MPH	
Minimum Sight Dist. for Stopping: 200'		Bridges: N/A	
Sight Dist. for No Passing Zone: N/A			
Pavement Design Life: N/A			
Design Accumulated One-Way Flexible ESALs: N/A			

STATE	PROJECT NO.	PCN	SECTION NO.	SHEET NO.
ND	HEU-8-984(179)	24053	1	1

NORTH DAKOTA DEPARTMENT OF TRANSPORTATION

HEU-8-984(179)
TR-26-A1
Fargo, Cass County
Intersection of University Dr N and 19th Ave N

Turn Lane Realignment, ADA Ramp
Updates, Traffic Signals, Lighting

GOVERNING SPECIFICATIONS	Date Published and Adopted by the North Dakota Department of Transportation
Standard Specifications	7/01/2024
Supplemental Specifications	NONE

PROJECT NUMBER \ DESCRIPTION	NET MILES	GROSS MILES
HEU-8-984(179)	0.10	0.10

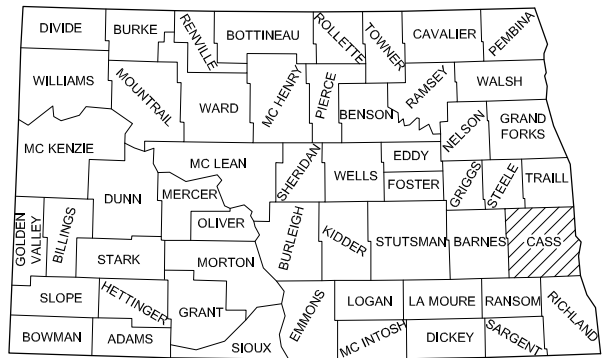
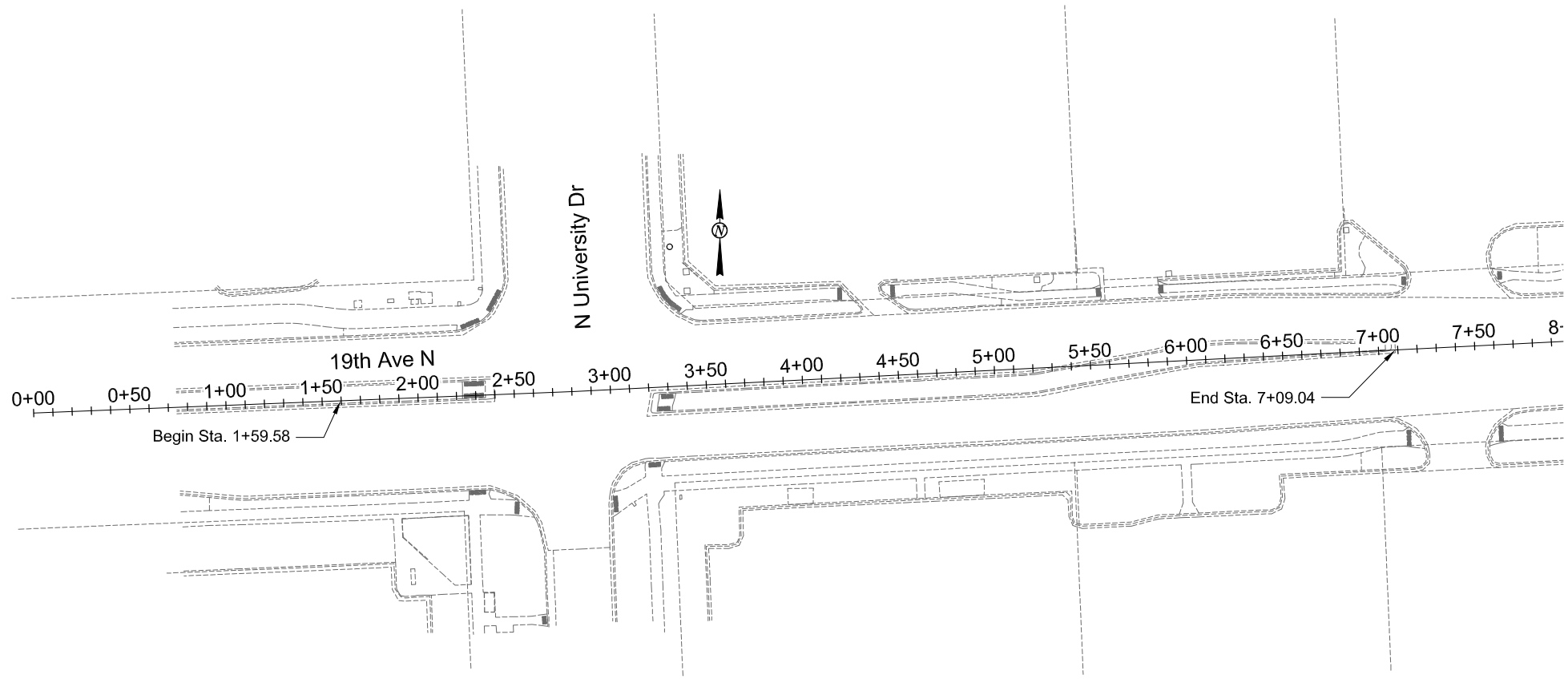

STATE COUNTY MAP

DESIGNER Matthew Huettl, PE
DESIGNER Moamer Maslesa, PE
DESIGNER Payton Wetzal, EI

CITY ENGINEER
Tom Knakmuhs
Digitally signed by Tom Knakmuhs
Date: 2025.08.28 07:05:37 -05'00'

HDR Engineering Inc.

08/19/25 10:12:54AM C:\pwworking\central01\44311311\001_Title_Sheet.dwg

TABLE OF CONTENTS

	STATE	PROJECT NO.	SECTION NO.	SHEET NO.
	ND	HEU-8-984(179)	2	1

PLAN SECTIONS

LIST OF STANDARD DRAWINGS

Section	Page(s)	Description
1	1	Title Sheet
2	1	Table of Contents
4	1	Scope of Work
6	1 - 3	Notes
8	1	Quantities
10	1	Basis of Estimate
20	1 - 2	General Details
30	1 - 2	Typical Sections
40	1	Removals
76	1	Temporary Erosion Control
77	1	Permanent Erosion Control
82	1 - 4	Survey Data Layouts
90	1 - 2	Layouts
100	1 - 18	Work Zone Traffic Control
110	1 - 3	Signing
120	1	Pavement Marking
140	1 - 5	Lighting
150	1 - 3	Signals
200	1 - 16	Cross Sections

Number	Description
D-101-1, 2, 3, 4	NDDOT Abbreviations
D-101-10	NDDOT Utility Company and Organization Abbreviations
D-101-20, 21	Line Styles
D-101-30, 31, 32, 33	Symbols
D-101-40	Cross Section Legend
D-550-3	Transverse Contraction Joint Details
D-550-4	Transverse Expansion Joint Detail
D-550-5	Transverse Construction Joint
D-704-7	Breakaway Systems For Construction Zone Signs - Perforated Tube
D-704-8	Breakaway Systems For Construction Zone Signs - U-Channel Post
D-704-9	Construction Sign Details - Terminal And Guide Signs
D-704-10	Construction Sign Details - Regulatory Signs
D-704-11, 11A	Construction Sign Details - Warning Signs
D-704-13	Barricade And Channelizing Device Details
D-704-14	Construction Sign Punching And Mounting Details
D-704-17	Sign Layout For One Lane Closure Two Lane Roadway
D-704-21	Detour And Roadway Diversion Sign Layouts
D-704-23	Short Term Urban Detour And Lane Closure On A Divided Highway Layouts
D-704-25	Lane Closures On Urban Streets Layouts
D-704-26	Miscellaneous Sign Layouts
D-704-32	Sign Layout For One Lane Closure Divided Highway Moving Operation
D-704-50	Portable Sign Support Assembly
D-748-1	Curb & Gutter And Valley Gutter
D-750-2	Sidewalk
D-750-3	Curb Ramp Retrofit Details
D-750-4	Curb Ramp Retrofit Transitional Area Details
D-754-80	Light Standard, Signal Standard, and Span Wire Mounted Sign Assembly Detail
D-762-1	Pavement Marking Message Details
D-762-4	Pavement Marking
D-770-1	Concrete Foundations (Traffic Signals & Highway Lighting)
D-770-2	Feed Points (Roadway Lighting)
D-770-2A	Combination Feed Point Details
D-770-3	Pull Box Details
D-770-4	Lighting And Signal Details
D-770-5	Light Standard Details
D-772-2	Traffic Signal Standards
D-772-3	Traffic Signal Standards (Mast Arm Type)
D-772-4	Traffic Signal Head Mounting
D-772-5	Loop Detector Details (Saw Slot)
D-772-5A	Loop Details

SPECIAL PROVISIONS

Number	Description
SP 234(24)	City Paving, Utility, and Landscaping Specifications
SP 235(24)	City Lighting and Traffic Signal Specifications
SP 236(24)	Utility Coordination
SP 264(24)	Temporary Pedestrian Facilities

STATE	PROJECT NO.	SECTION NO.	SHEET NO.
ND	HEU-8-984(179)	4	1

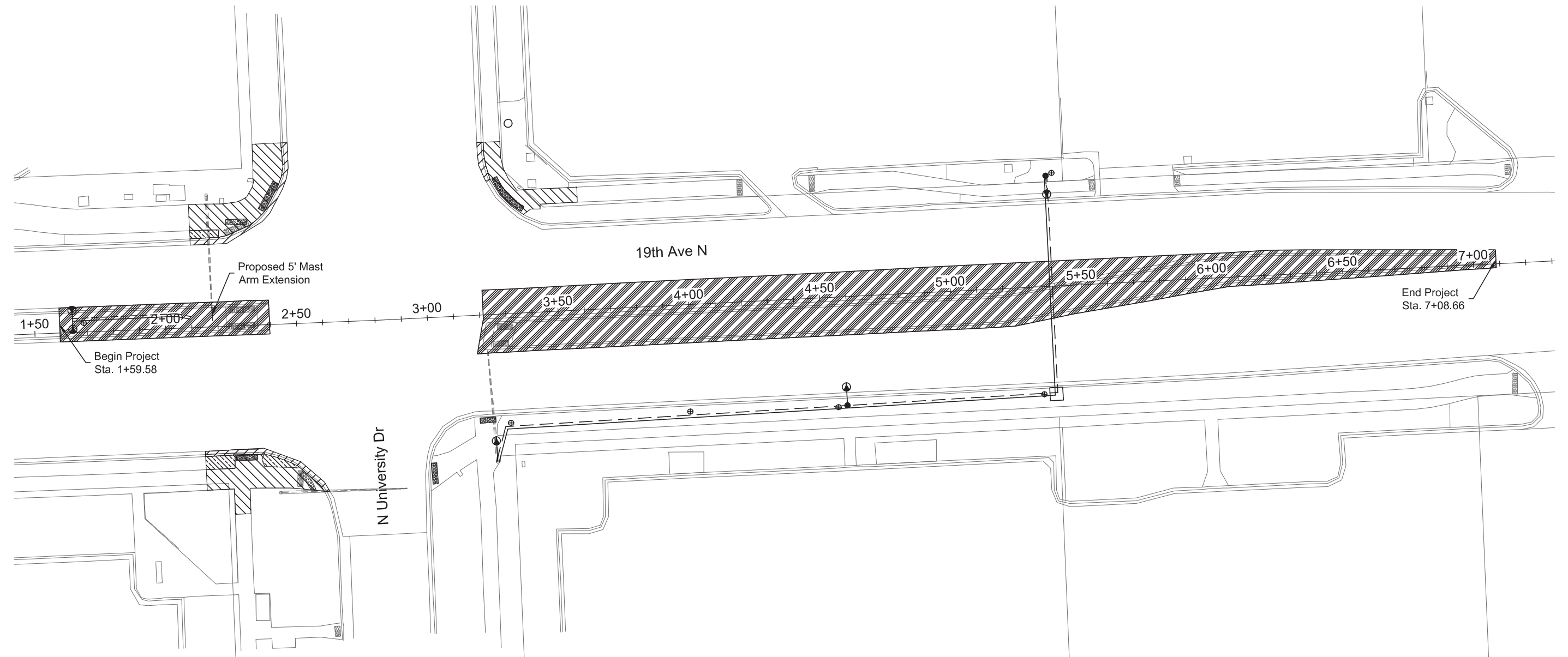

LEGEND

- Concrete Pavement
- Curb & Gutter
- Pigment Imprinted Concrete
- Sidewalk
- Lighting Conduit
- Proposed LED Luminaire
- Proposed Pull Box

Fargo Intersection Safety
Scope of Work

02/19/25 09:34:24AM C:\pwworking\central01\d4311311\004_Scope.dwg

STATE	PROJECT NO.	SECTION NO.	SHEET NO.
ND	HEU-8-984(179)	6	1

NOTES

- 100-P01 CONSTRUCTION SCHEDULE: Do not begin work prior to June 1st, 2026.
- 105-110 PAVEMENT SWEEPING: Sweep paved areas that were used by construction traffic before opening these areas to public traffic.

Sweep all newly constructed pavement no more than 24 hours before a scheduled final inspection.

Use a vacuum or pick-up type sweeper to perform this work.
- 105-P01 NOISE RESTRICTIONS: Conduct no construction activities or moving of equipment between the hours of 10:00 PM and 7:00 AM except for sawing of new concrete. When sawing is planned to occur during these hours, distribute written notices to residents located within ½ block of the work, a minimum of 4 hours prior to the start of any sawing.
- 105-P02 CONCRETE FLATWORK CERTIFICATIONS: All contractors performing concrete work, are required to have at least two employees with a current ACI concrete flatwork technician or flatwork finisher certification. At least one of the employees must be onsite performing quality control and guidance during all concrete work.
- 105-P03 SUPPLEMENTAL CONSTRUCTION SPECIFICATIONS: The City of Fargo Standard Specifications for Construction along with the plan notes will govern underground utility construction, concrete paving, curb and gutter, concrete sidewalks and driveways, landscaping, lighting, and traffic signals. The pertinent City specifications have been included in the following Special Provisions:

SP 234(24) City Paving, City Utility, and Landscaping Specifications

1000	Excavation, Trenching, and Backfilling for Underground Work
2100	Concrete Paving and Curbs & Gutters
2300	Concrete Sidewalks and Driveways
3300	Erosion and Sediment Control
4300	Signing
7000	Landscaping

SP 235(24) City Lighting and Traffic Signal Specifications

4200	Traffic Signals
4400	Street Lighting

Utility relocations/adjustments will be coordinated according to SP 236(24) "Utility Coordination".

Pedestrian WZTC will be coordinated according to SP 264(24) "Temporary Pedestrian Facilities".

- 105-P04 UTILITY COORDINATION AND PRECONSTRUCTION MEETING: A utility coordination meeting is required. The Contractor shall assist the City to organize, schedule, and attend a meeting with private utility companies and subcontractors at least 14 days prior to the start of construction for coordination purposes.
- 105-P05 POTHOLE UTILITY: Potholing is required for utility locations and depths around the proposed lighting system. Pothole locations are shown in Section 140. Backfilling the potholes with dirt to ground level will be included in the cost. Seeding and hydraulic mulch will be incidental to "POTHOLE UTILITY".
- 105-P06 STORM WATER REQUIREMENTS FOR EROSION AND SEDIMENT CONTROLS: The Contractor will be required to implement all erosion and sediment controls identified within the plans prior to beginning construction or progressing to the next phase of the project.

Along with the requirements specified within SP 234(24), the contractor shall also be required to adhere to the following:

Prior to beginning any concrete grinding or sawing operations, the Contractor must have the proper inlet protection in place at all inlets that may receive water from the grinding or sawing of the concrete. Once completed, the Contractor will be required to remove all concrete slurry that has settled out and properly dispose of it. Installation, maintaining, and removing the inlet protection for concrete grinding or sawing operations will be incidental to the bid item "INLET PROTECTION-SPECIAL". Storm Sewer Inlet Protection: Type C will be used.
- 108-100 WEEKLY PLANNING & REPORTING MEETING: A weekly planning and reporting meeting is required.
- 108-P01 FINAL COMPLETION DATE:

Do not begin work prior to June 1st, 2026.

The work must be completed within 48 consecutive working days.

Final completion shall consist of all work included in the contract. The final completion date will be adjusted accordingly based on the start date but shall in no case be later than August 15th. Working days will be calculated in accordance with Standard Specification 108.06, with the exception that Saturdays will be counted as working days.

Failure to meet completion dates will result in liquidated damages being applied per the contract.

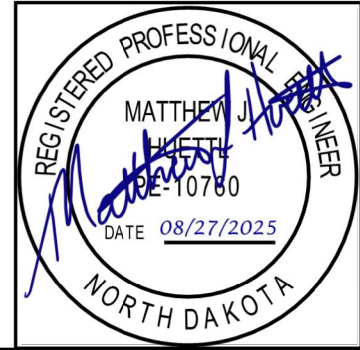

STATE	PROJECT NO.	SECTION NO.	SHEET NO.
ND	HEU-8-984(179)	6	2

NOTES

202-P01 REMOVAL OF CONCRETE PAVEMENT: Removal of concrete pavement consists of removing concrete and sidewalks. The square yards of "Removal of Concrete Pavement" are based on the plan view areas found in shown in Section 40.

Removal of Traffic Signal Loop Detectors will be incidental to the bid item for "REMOVAL OF PAVEMENT".

302-110 BASE COURSE: Trim base course as specified in 302.04 C.2, "Surface Tolerance Type B." This will be paid as "9IN REINF CONCRETE PAVEMENT CL AE".

302-P01 AGGREGATE BASE COURSE: Water will be incidental to bid item "AGGREGATE BASE COURSE CL 5".

704-100 TRAFFIC CONTROL SUPERVISOR: Provide a Traffic Control Supervisor.

704-P01 TRAFFIC CONTROL: The traffic control devices list has been developed using the following layouts shown on the Standard Drawings.

D-704-17: Sign Layout for One Lane Closure Two Lane Roadway
D-704-21: Detour and Roadway Diversion Sign Layouts
D-704-23: Short Term Urban Detour And Lane Closure On A Divided Highway Layout
D-704-25: Lane Closures On Urban Streets Layouts
D-704-26: Miscellaneous Sign Layouts
D-704-32: Sign Layout for One Lane Closure Divided Highway Moving Operation

704-P02 TRAFFIC CONTROL PHASING:

The construction phasing is listed below. Only one phase may be active at a time and each phase must be completed before proceeding to the next phase unless otherwise specified.

Phase 1

- Phase 1a
 - Install traffic control for construction of the turn lane.
 - Remove existing west bound left turn lane and adjacent median.
 - Pave new left turn lane and gore area.
 - Remove phase 1a and 1b traffic control before beginning phase 1c.
 - One east bound and west bound lane will be open for the entirety of this phase.
- Phase 1b
 - Install traffic control for construction of the concrete median nose paving.
 - Remove west median between stations 2+10.14 to 2+40.06.
 - Add concrete median nose paving.
 - Install 5' Traffic Signal Mast Arm Extension.
 - Remove phase 1a and 1b traffic control before beginning phase 1c.
 - One east bound and west bound lane will be open for the entirety of this phase.

Phase 2

- Phase 1c
 - Install traffic control for construction of the lighting system.
 - Install lighting and conduit.
 - Remove Phase 1c traffic control before beginning Phase 2a.
 - One east bound lane on the east side of the intersection will be closed for the duration of this phase.
 - Phase 1c can be constructed while Phase 2c is being constructed.
- Phase 2a
 - Install traffic control for construction of the NE ADA Ramp.
 - Remove and replace ADA Ramp as shown in plans.
 - Remove Phase 2a traffic control before beginning Phase 2b.
 - One west bound lane on the east side of the intersection will be closed for the duration of this phase.
- Phase 2b
 - Install traffic control for construction of the SW ADA Ramp.
 - Remove and replace ADA Ramp as shown in plans.
 - Remove Phase 2b traffic control before beginning Phase 2c.
 - One east bound lane on the west side of the intersection will be closed for the duration of this phase.
- Phase 2c
 - Install traffic control for construction of the NW ADA Ramp.
 - Remove and replace ADA Ramp as shown in plans.
 - Remove Phase 2c traffic control upon completion of work.
 - One west bound lane on the west side of the intersection will be closed for the duration of this phase.
 - Phase 2c can be constructed while Phase 1c is being constructed.

750-P01 DETECTABLE WARNING PANELS: Use cast-in-place, unpainted cast iron plates manufactured by East Jordan Iron Works, Neenah Foundry, or approved equal.

TufTile is not an approved equal for radial panels. Contractor will verify the required radius size of warning panels needed to best fit each curb radius as shown on plans.

750-P02 PIGMENTED IMPRINTED CONCRETE: The pigmented imprinted concrete color will match Solomon 338 Leather color or approved equivalent and stamped Pinwheel pattern along 19th Ave N. The color pigment shall be UV resistant and conform to ASTM C979 Standard Specification for Integrally Colored Concrete. Stamping, coloring of the imprinted concrete, and 2" class 5 aggregate base material required will be incidental to the bid item for "PIGMENTED IMPRINTED CONCRETE".

Concrete proportions and properties must conform to the requirements of SP 234(24) City Paving, City Utility, and Landscaping Specifications.

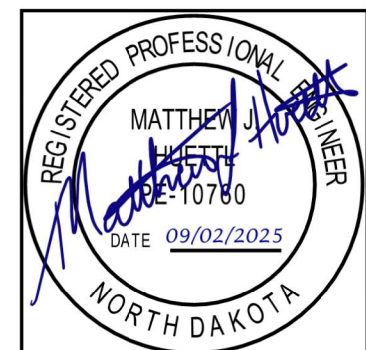

STATE	PROJECT NO.	SECTION NO.	SHEET NO.
ND	HEU-8-984(179)	6	3

NOTES

750-P03 CONCRETE SIDEWALKS: All expansion material will be ½ inch in thickness. All reinforcement will be a minimum of ½” diameter.

Expansion Joints – The “free” end of the smooth dowel must be coated with an approved lubricant and covered with an approved metal or plastic dowel cap or sleeve. All expansion joints will be sealed with low modulus silicone sealant to produce a slightly concave surface approximately ¼ inch below the concrete surface.

If uncontrolled cracking occurs, the Contractor must completely remove the concrete to the nearest planned longitudinal and transverse joints. The removal and replacement method must be approved by Engineer and will be at the Contractor’s expense.

Newly placed concrete will match the existing elevation (+/-1/8”) of all adjoining concrete. Any placed concrete not properly matching elevations as deemed by the Engineer will be removed and replaced at the contractor’s expense.

Concrete proportions and properties must conform to the requirements of SP 234(24) City Paving, City Utility, and Landscaping Specifications.

Reset landscaping will be incidental to bid item “SIDEWALK CONCRETE 5IN”.

750-P04 SIDEWALK & ADA CURB RAMP DETAILS: The Contractor is responsible for complying with all design standards outlined in Section 82 of these plans. Concrete landings will be placed separately and installed prior to adjacent ADA ramps and/or sidewalks. Minimum of 24 hours of cure time is required for concrete landings prior to adjacent concrete placement.

Sidewalk and ADA curb ramps will be constructed in accordance with details shown in Section 82 of these plans.

750-P05 ADA RAMP LAYOUT WORK: The boundary locations of proposed ADA ramps and the bottom of the curb transitions are shown in Section 82. Contractor will build per plans and current Federal ADA Standards.

Contractor will be responsible for correcting deficient ramps that don’t comply with Federal ADA Standards.

Layout work will be incidental to bid item “SIDEWALK CONCRETE 5IN”.

750-P06 SEEDING: Contractor will seed disturbed areas from installation of sidewalk, pull box installation and street lighting. All costs for labor, equipment, and material necessary to seed disturbed areas will be incidental to “SIDEWALK CONCRETE 5IN”, “PULL BOX”, AND “LIGHTING SYSTEM”.

Seeding will follow specifications in SP 234(24). Seeding mix consists of:

Perennial Ryegrass	40%
Creeping Red Fescue	30%
Annual Ryegrass	15%
Kentucky Bluegrass	15%

Application rates of 300 pounds per acre will be used. Fertilizer will be 24-24-4 at an application rate of 200 pounds per acre.

750-P07 HYDRAULIC MULCH: Contractor will install hydraulic mulch over seeded areas. All costs for labor, equipment, and material necessary to install hydraulic mulch will be incidental to “SIDEWALK CONCRETE 5IN”, “PULL BOX”, AND “LIGHTING SYSTEM”.

762-P01 CONCRETE MEDIAN NOSE PAINTING: Concrete median nose painting will be incidental to bid item “CONCRETE MEDIAN NOSE PAVING”.

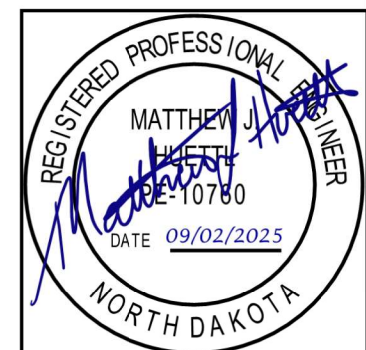

Estimated Quantities

STATE	PROJECT NO.	SECTION NO.	SHEET NO.
ND	HEU-8-984(179)	8	1

SPEC	CODE	ITEM DESCRIPTION	UNIT	HEU-8-984(179)	TOTAL
103	0100	CONTRACT BOND	L SUM	1	1
105	0200	POTHOLE UTILITY	EA	6	6
202	0128	REMOVE AGGREGATE BASE	TON	391	391
202	0130	REMOVAL OF CURB & GUTTER	LF	974	974
202	0136	REMOVAL OF PAVEMENT	TON	282	282
302	0120	AGGREGATE BASE COURSE CL 5	TON	15	15
550	0131	9IN REINF CONCRETE PAVEMENT CL AE	SY	859	859
702	0100	MOBILIZATION	L SUM	1	1
704	1000	TRAFFIC CONTROL SIGNS	UNIT	684	684
704	1052	TYPE III BARRICADE	EA	12	12
704	1054	SIDEWALK BARRICADE	EA	2	2
704	1058	PEDESTRIAN WALKWAY	LF	114	114
704	1060	DELINEATOR DRUMS	EA	85	85
704	1067	TUBULAR MARKERS	EA	22	22
704	2108	TEMPORARY CURB RAMP	EA	2	2
704	2200	TEMPORARY PEDESTRIAN SURFACING	SY	22.6	22.6
708	1540	INLET PROTECTION-SPECIAL	EA	6	6
748	0140	CURB & GUTTER-TYPE I	LF	126	126
750	0030	PIGMENTED IMPRINTED CONCRETE	SY	61	61
750	0125	SIDEWALK CONCRETE 5IN	SY	140	140
750	0210	CONCRETE MEDIAN NOSE PAVING	SY	5	5
750	2115	DETECTABLE WARNING PANELS	SF	76	76
754	0110	FLAT SHEET FOR SIGNS-TYPE XI REFL SHEETING	SF	8	8
754	0210	GALV STEEL POST-STANDARD PIPE	LF	34	34
762	0112	EPOXY PVMT MK MESSAGE	SF	64	64
762	0113	EPOXY PVMT MK 4IN LINE	LF	954	954
762	0115	EPOXY PVMT MK 8IN LINE	LF	1009	1009
762	0116	EPOXY PVMT MK 16IN LINE	LF	48	48
762	0117	EPOXY PVMT MK 24IN LINE	LF	314	314
770	0001	LIGHTING SYSTEM	EA	1	1
770	0100	PULL BOX	EA	1	1
770	4567	REMOVE LIGHTING SYSTEM	EA	1	1
770	4579	REMOVE PULL BOX	EA	1	1
772	0001	TRAFFIC SIGNALS SYSTEM	EA	1	1

STATE	PROJECT NO.	SECTION NO.	SHEET NO.
ND	HEU-8-984(179)	10	1

762-0112 - EPOXY PVMT MK MESSAGE (WHITE)				
Station		Quantity		
4+33	RT	16	SF	
5+08	RT	16	SF	
6+22	RT	16	SF	
6+58	RT	16	SF	
TOTAL		64	LF	

762-0113 - EPOXY 4IN YELLOW DOUBLE BARRIER					
Station to		Station		Quantity	
3+42	Rt	7+09	CL	736	LF
6+06	Rt	7+09	Lt	218	LF
TOTAL				954	LF

762-0115 - EPOXY 8IN WHITE LINE					
Station to		Station		Quantity	
3+42	Lt	6+22	Lt	280	LF
3+42	Rt	6+22	Lt	280	LF
3+42	CL	6+22	CL	282	LF
6+07	Rt	7+09	Rt	102	LF
TOTAL				944	LF

762-0116 - EPOXY 8IN YELLOW LINE					
Station to		Station		Quantity	
6+06	Lt	7+09	Rt	65	LF
TOTAL				65	LF

762-0116 - EPOXY 16IN WHITE LINE					
Station to		Station		Quantity	
3+41	Lt	3+41	Rt	48	LF
TOTAL				48	LF

762-0117 - EPOXY 24IN WHITE LINE					
Station to		Station		Quantity	
2+24	Lt	2+24	Rt	200	LF
3+08	Lt	3+41	Rt	114	LF
TOTAL				314	LF

QUANTITY SUMMARY					
SPEC	CODE	DESCRIPTION		QUANTITY	UNIT
762	0112	EPOXY PVMT MK MESSAGE (WHITE)		64	SF
762	0113	EPOXY PVMT MK-4IN LINE (YELLOW)		954	LF
762	0115	EPOXY PVMT MK-8IN LINE (WHITE)		944	LF
762	0115	EPOXY PVMT MK-8IN LINE (YELLOW)		65	LF
762	0116	EPOXY PVMT MK-16IN LINE (WHITE)		48	LF
762	0117	EPOXY PVMT MK-24IN LINE (WHITE)		314	LF

02/19/25 09:33:03AM C:\pwworking\central01\d4311311\010_BasisofEstimate.dwg

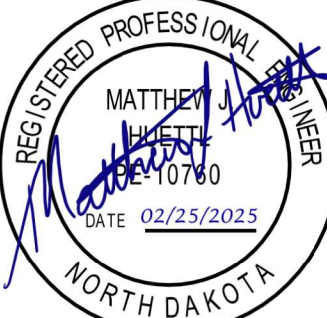
Fargo Intersection Safety Basis of Estimate	
--	---

STATE	PROJECT NO.	SECTION NO.	SHEET NO.
ND	HEU-8-984(179)	20	1

HOT POUR JOINT SEALANT INSTALLED FLUSH TO 3/8" BELOW TOP OF CONCRETE SURFACE

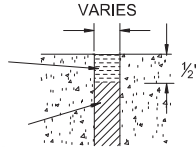

EXPANSION MATERIAL INSTALLED BELOW TOP OF CONCRETE WILL REQUIRE JOINT SEALANT (SEE NOTE 5)

JOINT W/ SEALANT DETAIL
APPLICABLE TO ALL EXPANSION JOINTS

EXPANSION MATERIAL INSTALLED FLUSH WITH TOP OF CONCRETE WILL NOT REQUIRE JOINT SEALANT. (SEE NOTE 5)

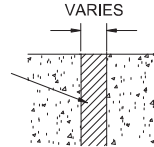

JOINT W/O SEALANT DETAIL
APPLICABLE TO ALL EXPANSION JOINTS

NOTES:

1. ALL EXPANSION MATERIAL SHALL BE INSTALLED FLUSH WITH THE TOP OF CONCRETE AND TIGHT AGAINST THE VERTICAL FACES. WHEN INSTALLED AS SPECIFIED, HOT POUR SEALANT WILL NOT BE REQUIRED. SEE SECTION 3.8.5, EXPANSION AND ISOLATION JOINTS IN STANDARD SPECIFICATIONS.

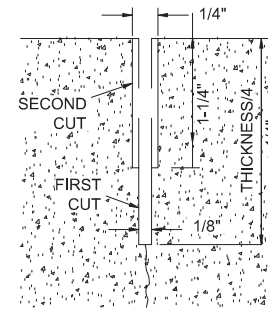

TRANSVERSE SAWED JOINT
(SEE JOINT SEALANT DETAIL)

HOT POUR JOINT SEALANT INSTALLED FLUSH TO 1/8" BELOW TOP OF CONCRETE PAVEMENT

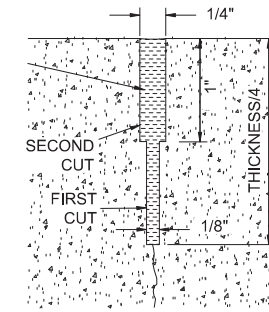

LONGITUDINAL SAWED JOINT

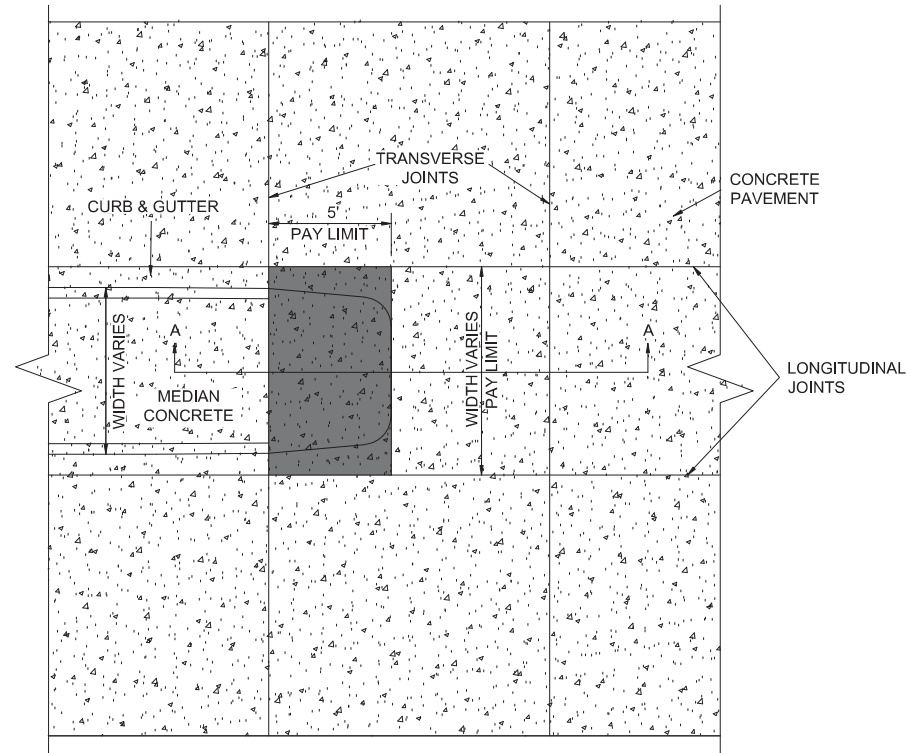

CONCRETE MEDIAN NOSE DETAIL

NOTE:
CONCRETE MEDIAN NOSE PAINTING WILL BE INCIDENTAL TO BID ITEM "CONCRETE MEDIAN NOSE PAVING"

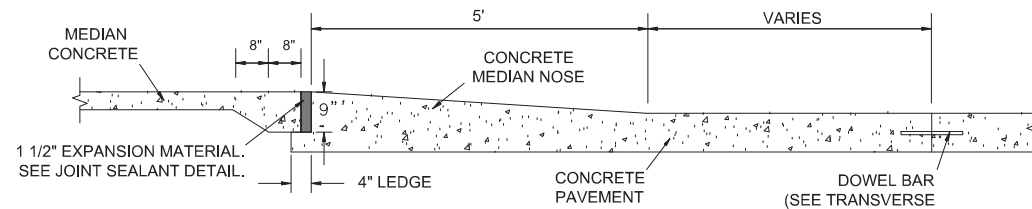

SECTION A-A

NOTE:
PAID AS "CONCRETE MEDIAN NOSE PAVING"

HOT POUR JOINT SEALANT INSTALLED FLUSH TO 1/8" BELOW TOP OF CONCRETE PAVEMENT

3/8" DIAMETER CLOSED CELL BACKER ROD

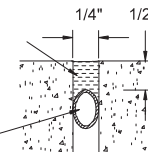

JOINT SEALANT DETAIL
ALL TRANSVERSE JOINTS

NOTES:

1. ALL LONGITUDINAL AND TRANSVERSE JOINTS SHALL BE FILLED WITH HOT POUR.
2. TRANSVERSE SAWED JOINTS, BACKER ROD AND JOINT SEALANT SHALL EXTEND THROUGH ENTIRE CURB & GUTTER SECTION.
3. ALL CONCRETE JOINT SEALANT AND BACKER ROD SHALL BE IN ACCORDANCE WITH SPECIFICATIONS.

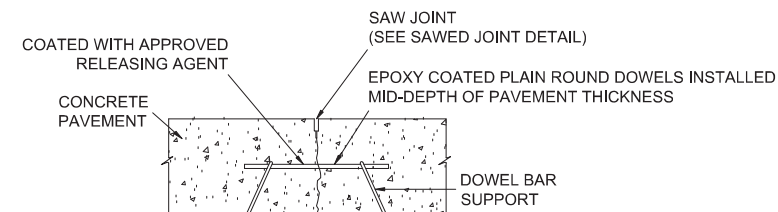

TRANSVERSE CONTRACTION JOINT
DOWEL ASSEMBLY

NOTE:

1. ALL DOWELS SHALL BE EPOXY COATED IN ACCORDANCE WITH ASTM A 775, EXCEPT EXPOSED ENDS RESULTING FROM SAW CUTTING OR SHEARING.

Fargo Intersection Safety

Median Nose Detail

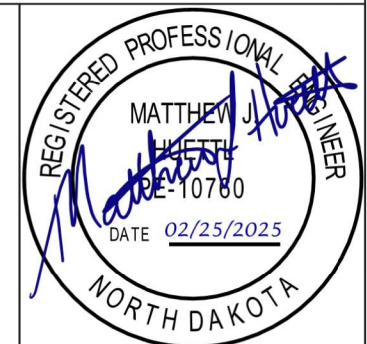

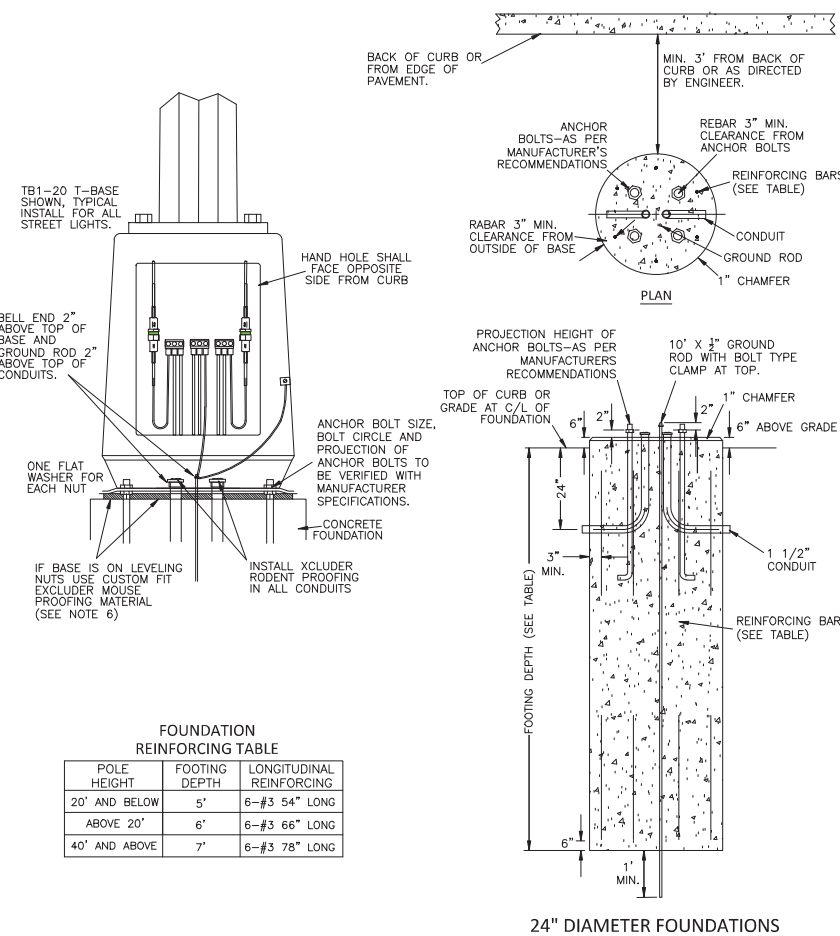

- NOTES:**
- SEE PLANS FOR CORRECT LOCATION OF FOUNDATION. THE GRADE AND EXACT LOCATION SHALL BE ESTABLISHED BY THE ENGINEER IN THE FIELD.
 - ANCHOR BOLT SIZE, BOLT CIRCLE AND PROJECTION OF ANCHOR BOLTS TO BE VERIFIED WITH MANUFACTURER SPECIFICATIONS.
 - THE FOUNDATION SHALL PROVIDE A MINIMUM OF 3" OF CONCRETE COVER FROM THE ANCHOR BOLTS TO THE REBAR, AND A MINIMUM OF 3" OF CONCRETE COVER OVER THE REBAR TO THE OUTSIDE OF THE FOUNDATION.
 - GROUND ROD SHALL BE PLACED PRIOR TO CONCRETE PLACEMENT. THE ROD SHALL PROJECT 4" ABOVE THE FINISHED FOUNDATION AND SHALL EXTEND A MINIMUM OF 12" BELOW THE FOUNDATION BOTTOM.
 - CONDUIT BENDS SHALL BE 90°. CONDUIT SHALL BE LOCATED 24" MINIMUM BELOW GROUND LEVEL. BASES AT THE END OF CIRCUIT WILL HAVE A SPARE CAPPED CONDUIT.
 - T-BASES XCLUDER LIGHT POLE GASKET 2800G ITEM#162728, (2) MAY BE NEEDED FOR PROPER SEAL.
 - ALL REINFORCING STEEL TO BE GRADE 40 OR 60.
 - SEE PLANS FOR CONDUIT SIZE, NUMBER OF BENDS AND CORRECT POSITIONING FOR EACH FOUNDATION.
 - THE TOP OF THE FOUNDATION SHALL BE CIRCULAR. IF APPROVED BY THE ENGINEER A SQUARE CASING MAY BE USED. PRIOR TO FINAL GRADING OR SIDEWALK PLACEMENT THE CASING TUBES SHALL BE REMOVED TO A POINT 6" BELOW GRADE.
 - IF FOUNDATIONS NEED TO BE INSTALLED NEAR EXISTING LOCATES SUCH AS, WATER OR SEWER PIPE, SHORING SHALL BE INSTALLED PRIOR TO CONCRETE PLACEMENT. IF VOIDS ARE CREATED DUE TO DRILLING FOUNDATIONS VOIDS SHALL BE FILLED WITH A CONCRETE FLOWABLE FILL.

- CONCRETE NOTES:**
- CONCRETE USED IN THE WORK SHALL BE PORTLAND CEMENT CONCRETE MIXED AND PROPORTIONED AS SPECIFIED IN SECTION 2100 OF THE CITY OF FARGO STANDARD SPECIFICATIONS FOR CONSTRUCTION.
 - CONTRACTOR IS RESPONSIBLE FOR CALLING OR NOTIFYING ENGINEER BEFORE CONCRETE IS ORDERED, NO CONCRETE SHALL BE INSTALLED UNTIL CONCRETE IS TESTED.
 - CONCRETE SHALL MEET THE FOLLOWING TESTS:
 - AIR CONTENT BETWEEN 5% TO 8%
 - SLUMP BETWEEN 2" TO 4"
 - MAX TEMP OF 90 DEGREES
 - CONCRETE SHALL ATTAIN A COMPRESSIVE STRENGTH OF 3500 PSI BEFORE STREET LIGHT STANDARD IS INSTALLED AND SHALL ATTAIN A COMPRESSIVE STRENGTH OF 4500 PSI WITHIN 28 DAYS TO BE ACCEPTED.
 - IF FOUNDATION IS DRILLED/EXCAVATED IN AN AREA THAT IS CAVING IN, THE AREA NEEDS TO BE SHORED TO A DEPTH THAT PREVENTS ANY CAVING IN. CONTRACTOR SHALL FILL AND COMPACT CAVED IN AREA AROUND FOUNDATION TO ENGINEERS SATISFACTION. IF CONTRACTOR IS NOT ABLE TO COMPACT TO 90% COMPACTION, FLOWABLE FILL SHALL BE USED.

CONCRETE BASE DETAIL

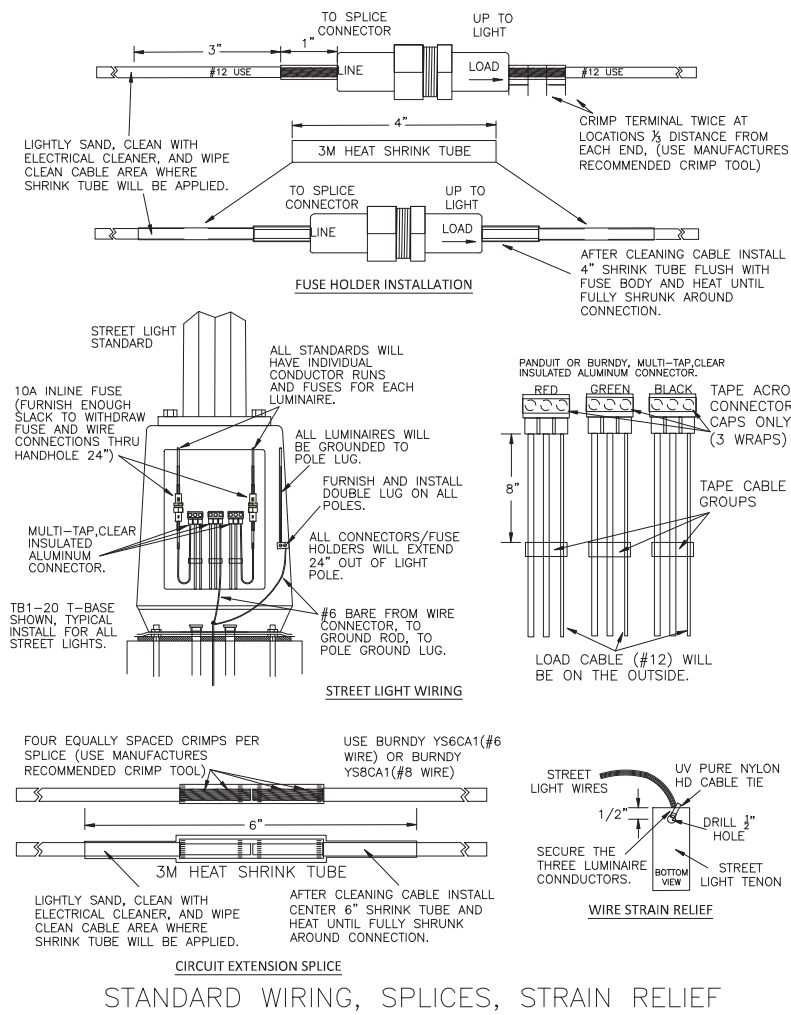

STANDARD WIRING, SPLICES, STRAIN RELIEF

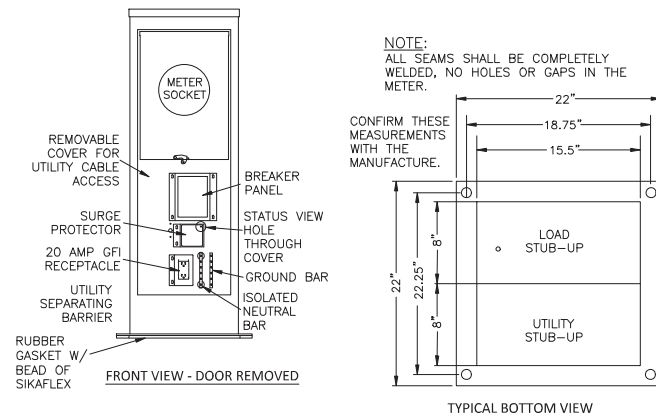

NOTE:
ALL SEAMS SHALL BE COMPLETELY WELDED, NO HOLES OR GAPS IN THE METER.

CONFIRM THESE MEASUREMENTS WITH THE MANUFACTURE.

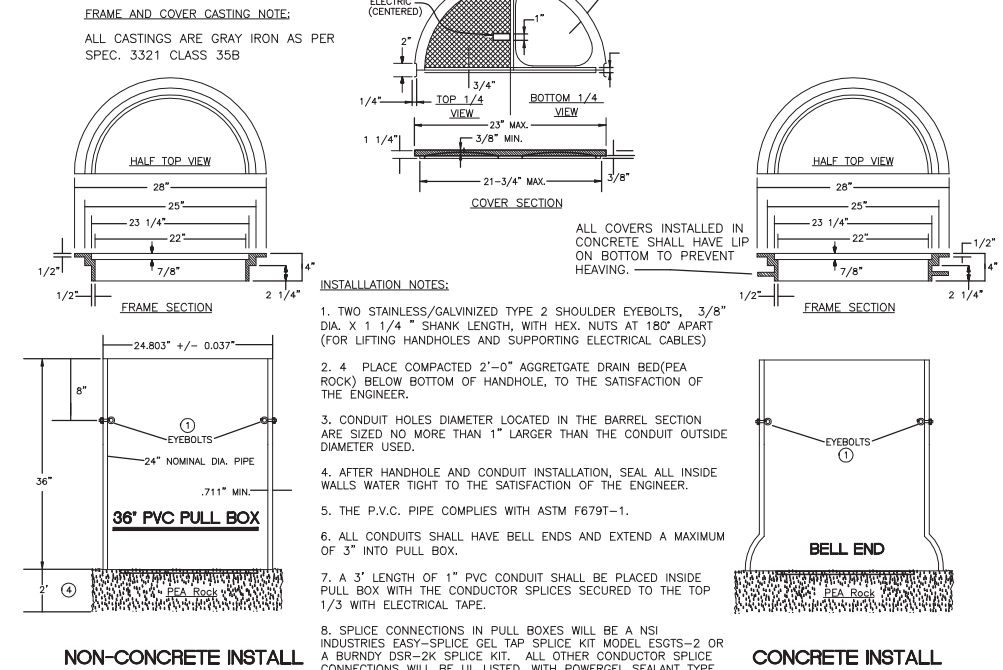

PULL BOX, METAL FRAME AND COVER DETAIL

Fargo Intersection Safety
Standard Street Light Foundations

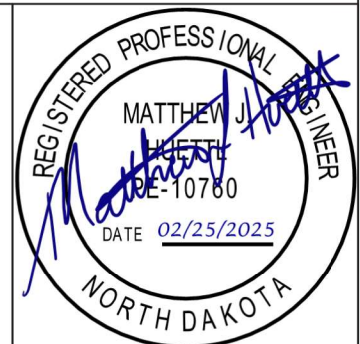

	STATE	PROJECT NO.	SECTION NO.	SHEET NO.
	ND	HEU-8-984(179)	30	1

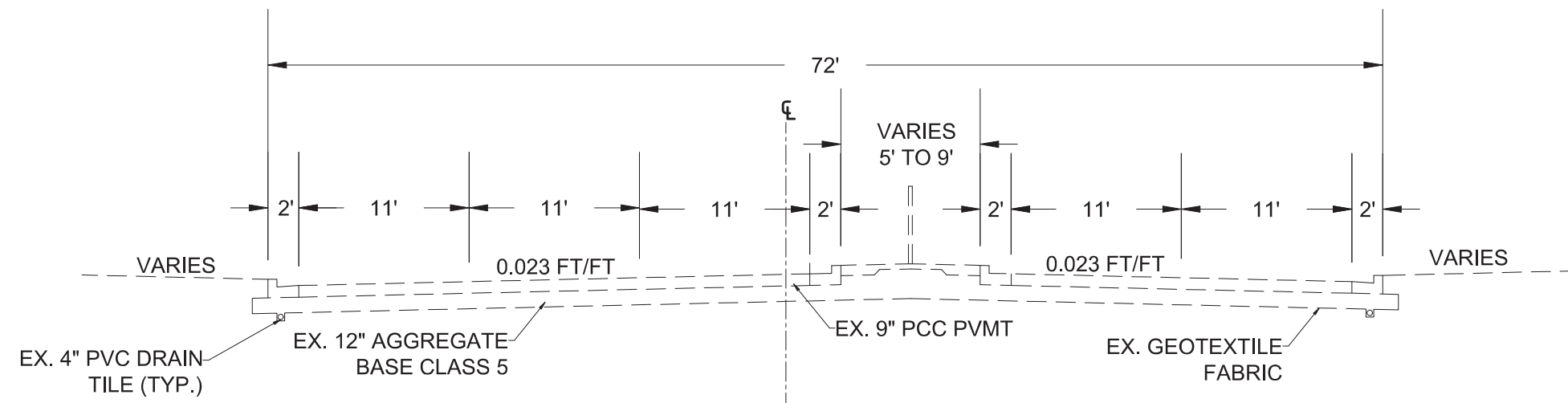

**EXISTING 19TH AVE N
STA. 3+18.46 TO STA. 6+05.78**

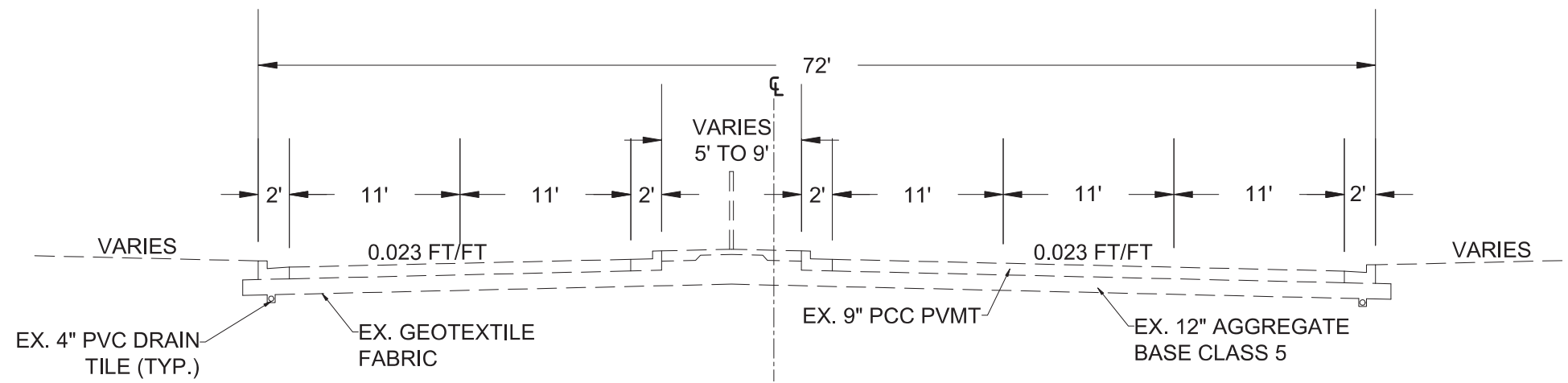

**EXISTING 19TH AVE N
STA. 6+05.78 TO STA. 7+09.00**

Fargo Intersection Safety
Typical Sections

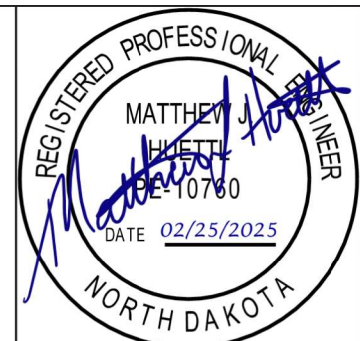

	STATE	PROJECT NO.	SECTION NO.	SHEET NO.
	ND	HEU-8-984(179)	30	2

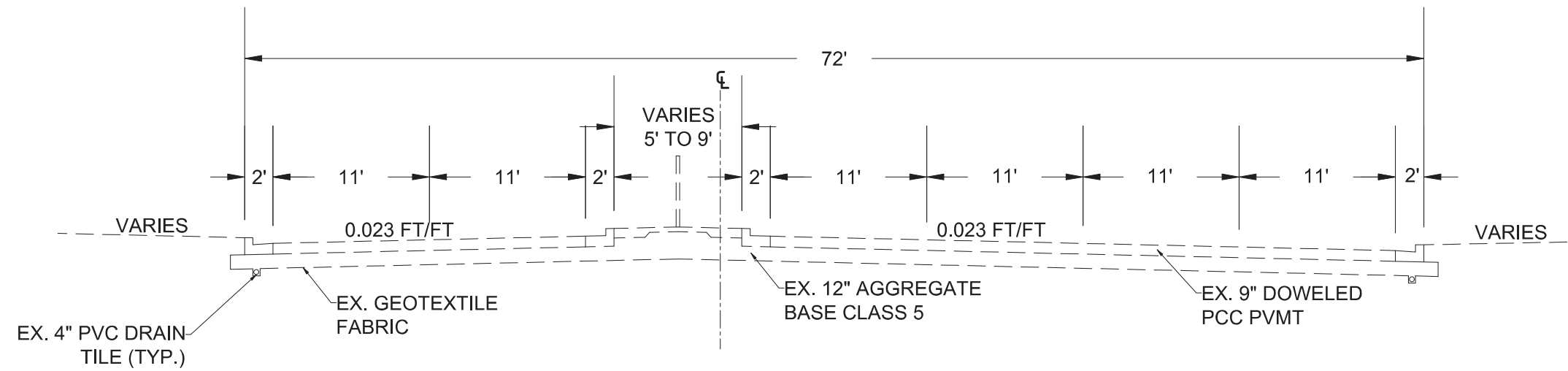

EXISTING 19TH AVE N
STA. 0+74.43 TO STA. 2+39.69

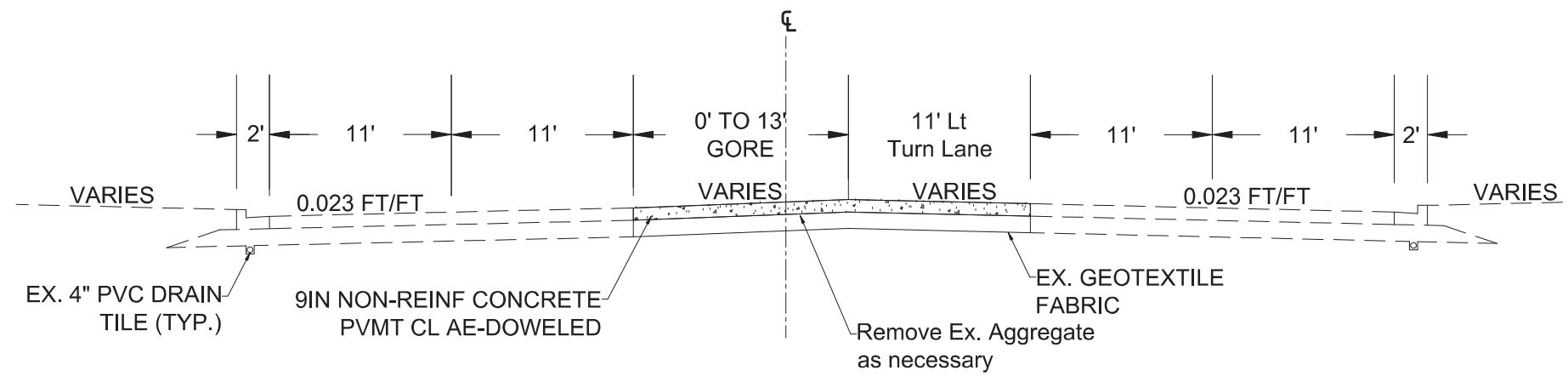

PROPOSED 19TH AVE N
STA. 3+40.54 TO STA. 7+09.00

Fargo Intersection Safety
 Typical Sections

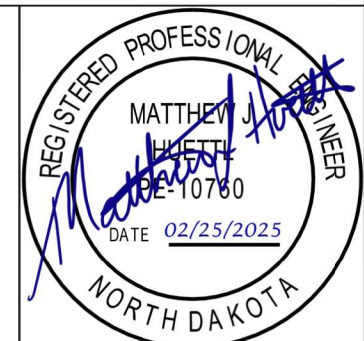

STATE	PROJECT NO.	SECTION NO.	SHEET NO.
ND	HEU-8-984(179)	40	1

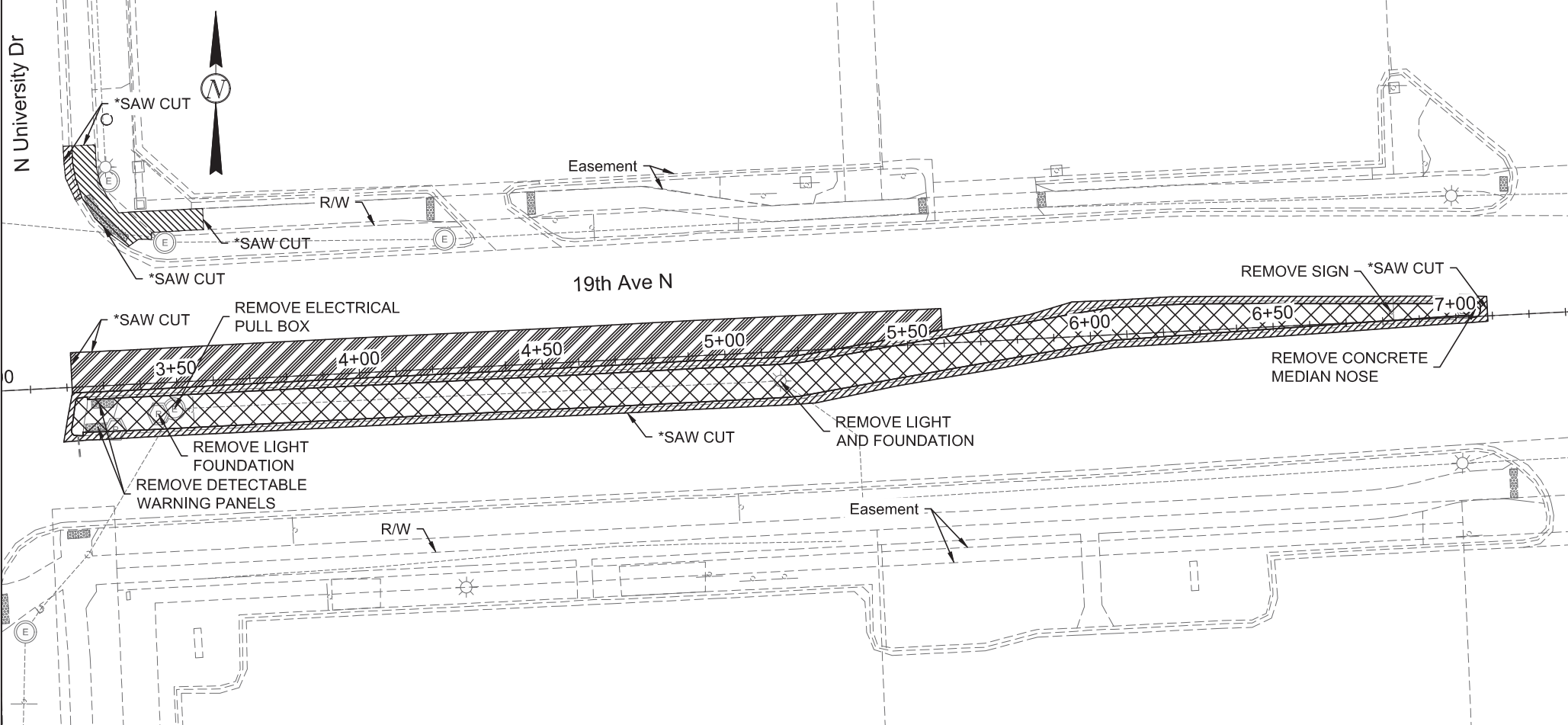
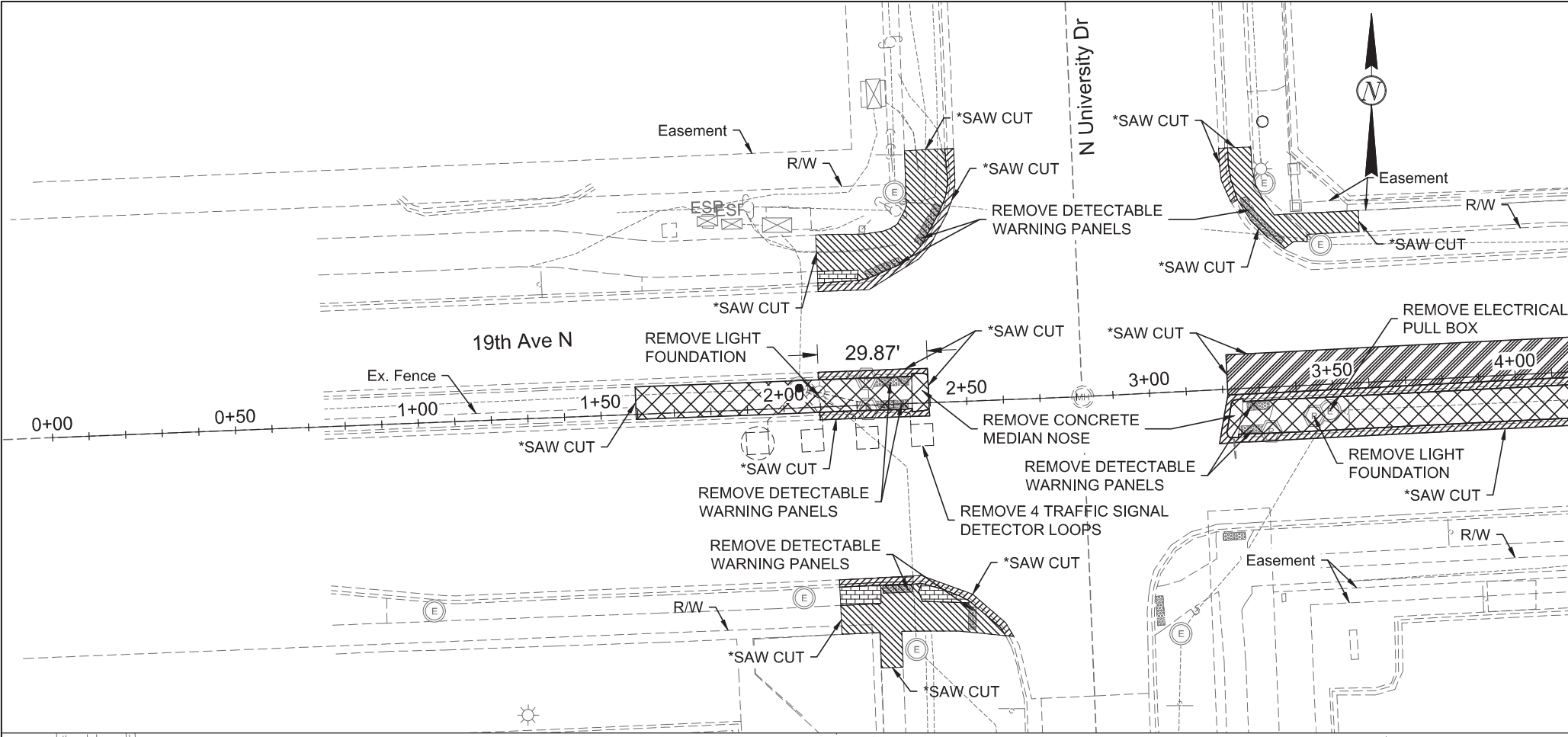

SPEC	CODE	BID ITEM	QUANTITY	UNIT
202	0136	REMOVAL OF PAVEMENT		
		Sta. 1+59.58 to Sta. 2+35.03	17	TON
		Sta. 2+10.14 to Sta. 2+39.66	3	TON
		Sta. 2+10.93 to Sta. 2+47.58	13	TON
		Sta. 2+10.97 to Sta. 2+22.15	1	TON
		Sta. 2+13.69 to Sta. 2+58.46	11	TON
		Sta. 2+13.69 to Sta. 3+59.86	1	TON
		Sta. 2+34.77 to Sta. 2+48.47	1	TON
		Sta. 3+20.93 to Sta. 3+25.79	2	TON
		Sta. 3+21.73 to Sta. 5+95.84	147	TON
		Sta. 3+18.76 to Sta. 7+09.04	79	TON
		Sta. 3+24.98 to Sta. 3+59.86	8	TON
		Sta. 7+03.99 to Sta. 7+07.17	1	TON
			282	TON
202	0128	REMOVE AGGREGATE BASE		
		Sta. 2+10.14 to Sta. 2+40.06	17	TON
		Sta. 3+18.76 to Sta. 7+09.04	261	TON
		Sta. 3+18.76 to Sta. 7+09.04	84	TON
		Sta. 3+24.98 to Sta. 3+59.86	7	TON
		Sta. 2+10.93 to Sta. 2+47.58	12	TON
		Sta. 2+13.69 to Sta. 2+58.46	10	TON
			391	TON
202	0130	REMOVAL OF CURB & GUTTER		
		Sta. 2+10.13 to Sta. 2+50.00	30	LF
		Sta. 2+10.15 to Sta. 2+50.11	30	LF
		Sta. 2+10.93 to Sta. 2+47.58	60	LF
		Sta. 2+13.69 to Sta. 2+58.46	51	LF
		Sta. 3+08.76 to Sta. 7+09.03	788	LF
		Sta. 3+24.98 to Sta. 3+27.01	15	LF
			974	LF

*Saw Cut is included in removal quantities

LEGEND

- REMOVAL OF CONCRETE
- REMOVAL OF CONCRETE MEDIAN
- REMOVAL OF CURB & GUTTER
- REMOVAL OF PIGMENT IMPRINTED CONCRETE
- REMOVAL OF SIDEWALK

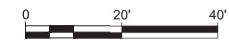

Fargo Intersection Safety
Removals

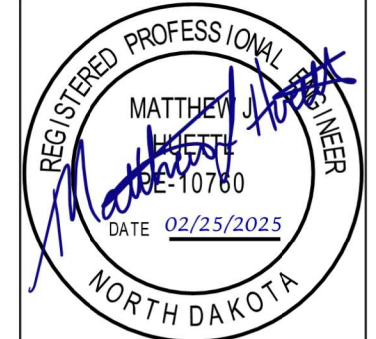

02/19/25 09:40:47AM C:\pwworking\central01\44311311\040_Removals.dwg

02/25/25 09:19:57AM C:\pwworking\central01\d4311311\076_Temporary_Erosion_Control.dwg



STATE	PROJECT NO.	SECTION NO.	SHEET NO.
ND	HEU-8-984(179)	76	1

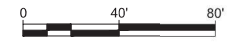

Fargo Intersection Safety
Temporary Erosion Control

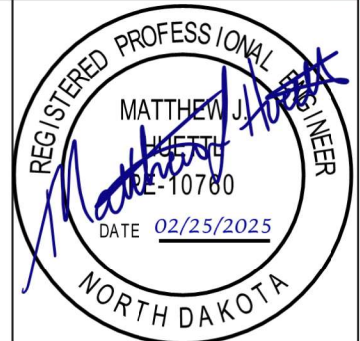

STATE	PROJECT NO.	SECTION NO.	SHEET NO.
ND	HEU-8-984(179)	77	1

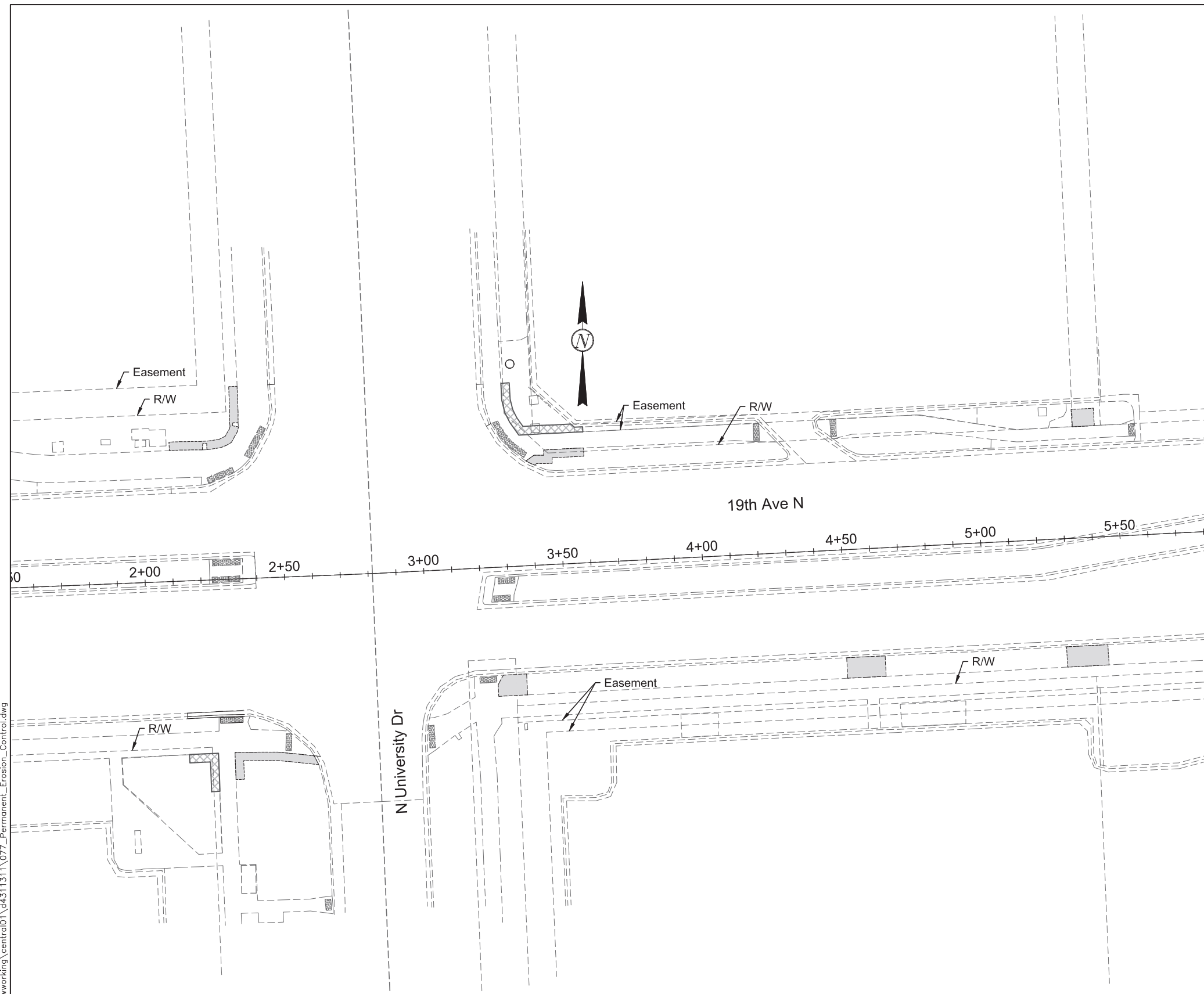

LEGEND

- Seeding Class II/Hydraulic Mulch
- Seeding Line
- Reset Landscaping

0 20' 40'

Fargo Intersection Safety
Permanent Erosion Control

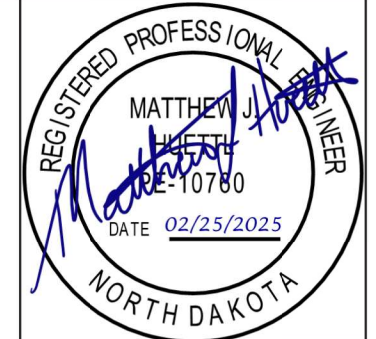

02/19/25 09:45:35AM C:\pwworking\central01\44311311\077_Permanent_Erosion_Control.dwg

STATE	PROJECT NO.	SECTION NO.	SHEET NO.
ND	HEU-8-984(179)	82	1



Line Table: Alignments - 19th Ave N					
Number	PI Station	Northing	Easting	Distance	Direction
L1	0+00.00	473315.75	2893211.10	281.55	N87° 42' 48.24"E
L2	2+81.55	473326.99	2893492.43	618.45	N87° 06' 44.28"E

<p>Fargo Intersection Safety</p> <p>Survey Data</p> <p>Alignment Definition</p>	
---	--

University Dr N

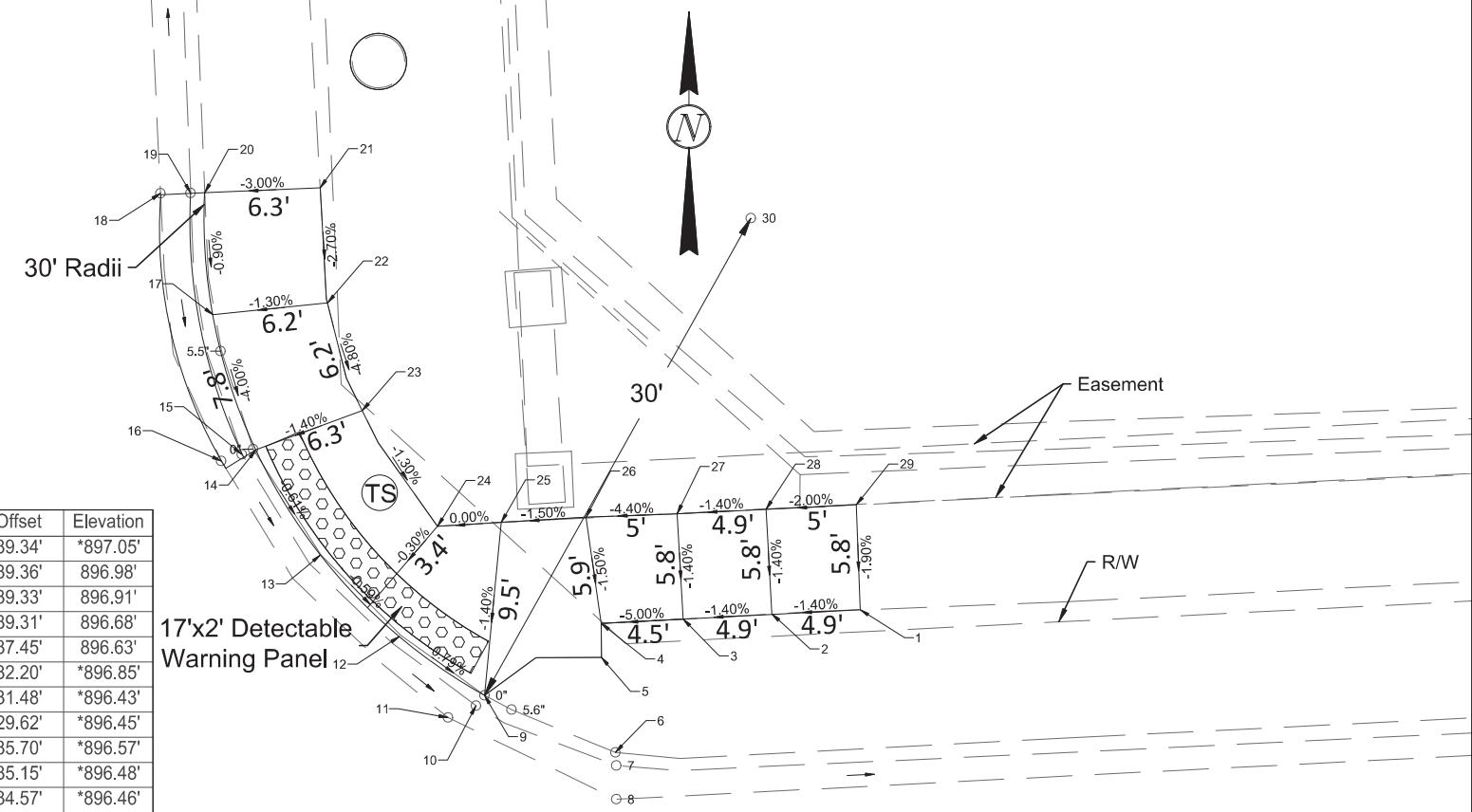

Point	Northing	Easting	Station	Offset	Elevation
1	473372.07	2893568.13	3+59.56	39.34'	*897.05'
2	473371.84	2893563.28	3+54.71	39.36'	896.98'
3	473371.56	2893558.40	3+49.83	39.33'	896.91'
4	473371.32	2893553.91	3+45.33	39.31'	896.68'
5	473369.46	2893553.92	3+45.24	37.45'	896.63'
6	473364.24	2893554.68	3+45.74	32.20'	*896.85'
7	473363.52	2893554.75	3+45.77	31.48'	*896.43'
8	473361.66	2893554.74	3+45.67	29.62'	*896.45'
9	473367.38	2893547.51	3+38.74	35.70'	*896.57'
10	473366.80	2893547.04	3+38.23	35.15'	*896.48'
11	473366.15	2893545.50	3+36.67	34.57'	*896.46'
12	473370.60	2893542.84	3+34.23	39.16'	*896.61'
13	473375.08	2893538.51	3+30.14	43.85'	*896.65'
14	473380.85	2893534.96	3+26.89	49.79'	896.71'
15	473380.61	2893534.20	3+26.11	49.59'	*896.58'
16	473380.24	2893533.06	3+24.96	49.28'	*896.57'
17	473388.27	2893532.60	3+24.90	57.32	897.02'
18	473394.93	2893529.73	3+22.37	64.12'	*896.66'
19	473394.96	2893531.38	3+24.02	64.06'	*896.63'
20	473394.97	2893532.16	3+24.80	64.03'	*897.08'
21	473395.23	2893538.49	3+31.13	63.97'	*897.27'
22	473392.84	2893525.79	3+18.31	39.34'	*897.05'
23	473394.32	2893524.02	3+16.62	39.36'	896.98'
24	473395.80	2893522.25	3+14.92	39.33'	896.91'
25	473397.28	2893520.49	3+13.23	39.31'	896.68'
26	473398.76	2893518.72	3+11.54	37.45'	896.63'
27	473400.25	2893516.95	3+09.85	32.20'	*896.85'
28	473401.73	2893515.18	3+08.16	31.48'	*896.43'
29	473403.21	2893513.42	3+06.47	29.62'	*896.45'
30	473393.58	2893562.13	3+54.66	61.13'	-

*Match existing elevations

- Flow Arrow
- (TS) Turning Space
1.5% Maximum Slope (All. Dir.)

Notes:
1. Dimensions shown may vary from actual. contractor will field fit adjust if maximum slopes can not be met with dimensions shown.

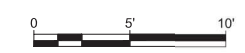

19th Ave N

Fargo Intersection Safety
ADA Ramp Details - NE

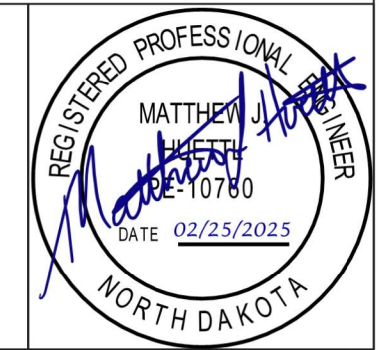

02/19/25 12:10:50PM C:\pwworking\central01\44311308\Ramp_Exhibits_Sheets.dwg

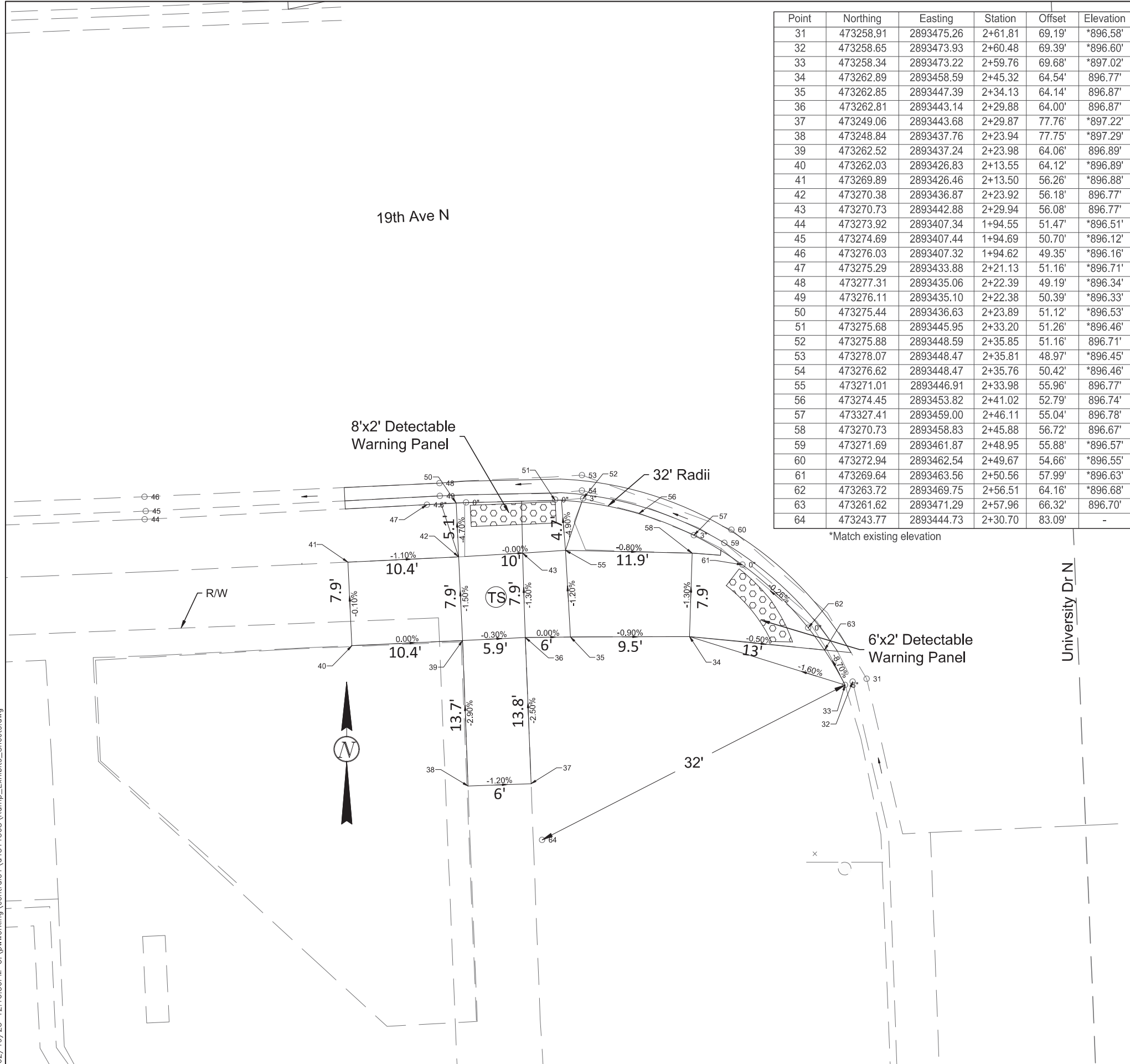

Point	Northing	Easting	Station	Offset	Elevation
31	473258.91	2893475.26	2+61.81	69.19'	*896.58'
32	473258.65	2893473.93	2+60.48	69.39'	*896.60'
33	473258.34	2893473.22	2+59.76	69.68'	*897.02'
34	473262.89	2893458.59	2+45.32	64.54'	896.77'
35	473262.85	2893447.39	2+34.13	64.14'	896.87'
36	473262.81	2893443.14	2+29.88	64.00'	896.87'
37	473249.06	2893443.68	2+29.87	77.76'	*897.22'
38	473248.84	2893437.76	2+23.94	77.75'	*897.29'
39	473262.52	2893437.24	2+23.98	64.06'	896.89'
40	473262.03	2893426.83	2+13.55	64.12'	*896.89'
41	473269.89	2893426.46	2+13.50	56.26'	*896.88'
42	473270.38	2893436.87	2+23.92	56.18'	896.77'
43	473270.73	2893442.88	2+29.94	56.08'	896.77'
44	473273.92	2893407.34	1+94.55	51.47'	*896.51'
45	473274.69	2893407.44	1+94.69	50.70'	*896.12'
46	473276.03	2893407.32	1+94.62	49.35'	*896.16'
47	473275.29	2893433.88	2+21.13	51.16'	*896.71'
48	473277.31	2893435.06	2+22.39	49.19'	*896.34'
49	473276.11	2893435.10	2+22.38	50.39'	*896.33'
50	473275.44	2893436.63	2+23.89	51.12'	*896.53'
51	473275.68	2893445.95	2+33.20	51.26'	*896.46'
52	473275.88	2893448.59	2+35.85	51.16'	896.71'
53	473278.07	2893448.47	2+35.81	48.97'	*896.45'
54	473276.62	2893448.47	2+35.76	50.42'	*896.46'
55	473271.01	2893446.91	2+33.98	55.96'	896.77'
56	473274.45	2893453.82	2+41.02	52.79'	896.74'
57	473327.41	2893459.00	2+46.11	55.04'	896.78'
58	473270.73	2893458.83	2+45.88	56.72'	896.67'
59	473271.69	2893461.87	2+48.95	55.88'	*896.57'
60	473272.94	2893462.54	2+49.67	54.66'	*896.55'
61	473269.64	2893463.56	2+50.56	57.99'	*896.63'
62	473263.72	2893469.75	2+56.51	64.16'	*896.68'
63	473261.62	2893471.29	2+57.96	66.32'	896.70'
64	473243.77	2893444.73	2+30.70	83.09'	-

*Match existing elevation

STATE	PROJECT NO.	SECTION NO.	SHEET NO.
ND	HEU-8-984(179)	82	3

- Flow Arrow
- (TS) Turning Space
1.5% Maximum Slope (All. Dir.)

Notes:
1. Dimensions shown may vary from actual. contractor will field fit adjust if maximum slopes can not be met with dimensions shown.



Fargo Intersection Safety
ADA Ramp Details - SW

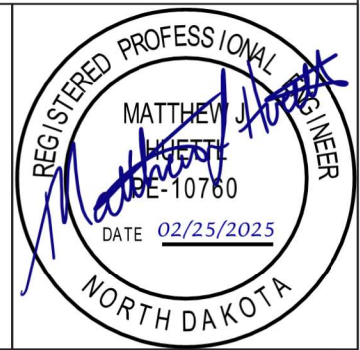

02/19/25 11:25:10AM C:\pwworking\central01\d44311311\090_Paving.dwg

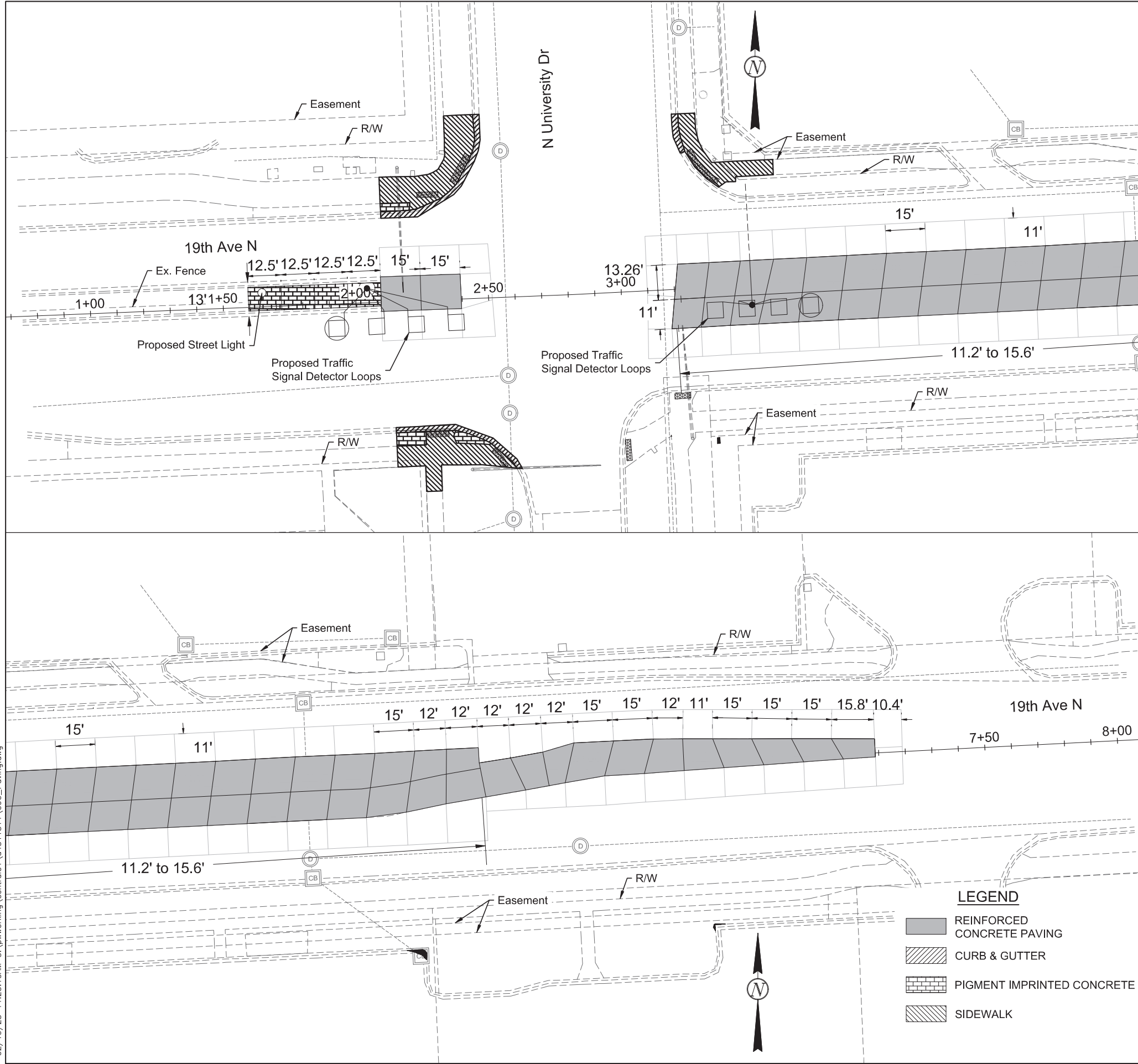

STATE	PROJECT NO.	SECTION NO.	SHEET NO.
ND	HEU-8-984(179)	90	1

SPEC	CODE	BID ITEM	QUANTITY	UNIT
302	0120	AGGREGATE BASE COURSE CL 5		
		Sta. 3+24.98 to Sta. 3+59.86 (Sidewalk)	4	TON
		Sta. 2+10.93 to Sta. 2+47.58 (Sidewalk)	6	TON
		Sta. 2+13.69 to Sta. 2+58.46 (Sidewalk)	5	TON
			15	TON
550	0131	9IN REINF CONCRETE PVMT CL AE		
		Sta. 2+09.56 to Sta. 2+39.70	43	SY
		Sta. 3+18.39 to Sta. 7+08.68	816	SY
			859	SY
748	0140	CURB & GUTTER-TYPE 1		
		Sta. 3+24.98 to Sta. 3+27.01	15	LF
		Sta. 2+10.93 to Sta. 2+47.58	60	LF
		Sta. 2+13.69 to Sta. 2+58.46	51	LF
			126	LF
750	0030	PIGMENTED IMPRINTED CONCRETE		
		Sta. 1+59.58 to Sta. 2+09.76	46	SY
		Sta. 2+10.97 to Sta. 2+22.15	4	SY
		Sta. 2+13.69 to Sta. 3+59.86	6	SY
		Sta. 2+34.77 to Sta. 2+48.47	5	SY
			61	SY
750	0125	SIDEWALK CONCRETE 5IN		
		Sta. 2+10.93 to Sta. 2+47.58	58	SY
		Sta. 2+13.69 to Sta. 2+58.46	48	SY
		Sta. 3+24.98 to Sta. 3+59.86	34	SY
			140	SY
750	0210	CONCRETE MEDIAN NOSE PAVING		
		Sta. 2+10.14 to Sta. 2+15.14	5	SY
750	2115	DETECTABLE WARNING PANELS		
		Sta. 2+23.93 to Sta. 2+33.93	20	SF
		Sta. 2+25.47 to Sta. 2+33.50	16	SF
		Sta. 2+37.75 to Sta. 2+45.50	24	SF
		Sta. 2+48.40 to Sta. 2+50.68	16	SF
			76	SF

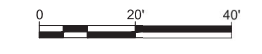

LEGEND

	REINFORCED CONCRETE PAVING
	CURB & GUTTER
	PIGMENT IMPRINTED CONCRETE
	SIDEWALK

Fargo Intersection Safety
Paving Layout

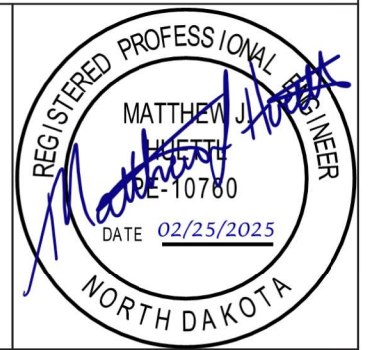

STATE	PROJECT NO.	SECTION NO.	SHEET NO.
ND	HEU-8-984(179)	90	2

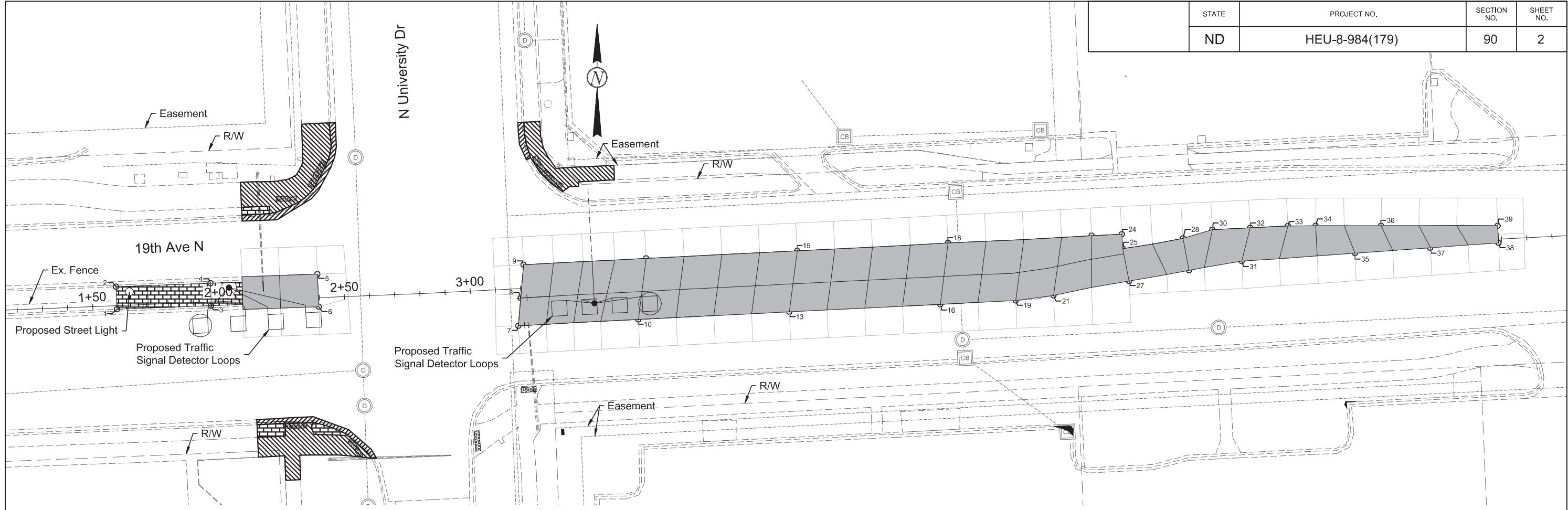

Point	Station	Offset	Elevation	Point	Station	Offset	Elevation
1	1+59.58	1.39' Rt	*896.80'	20	5+18.17	3.50' Rt	896.12'
2	1+59.59	7.51' Lt	*896.50'	21	5+31.23	13.37' Lt	*895.97'
3	1+97.03	1.47' Rt	*897.03'	22	5+33.40	1.89' Rt	897.26'
4	1+97.12	7.43' Lt	*896.74'	23	5+47.51	9.51' Lt	*896.64'
5	2+39.61	9.37' Lt	*896.94'	24	5+59.53	9.54' Lt	*896.66'
6	2+39.73	3.60' Rt	*897.20'	25	5+59.56	3.79' Lt	*896.78'
7	3+18.39	14.77' Rt	*896.90'	26	5+59.86	1.73' Lt	896.47'
8	3+19.88	3.76' Rt	*897.01'	27	5+61.46	9.16' Rt	*896.25'
9	3+21.66	9.40' Lt	*896.88'	28	5+83.69	6.66' Lt	*896.88'
10	3+66.12	14.59' Rt	*896.62'	29	5+85.40	6.14' Rt	*896.45'
11	3+68.09	3.59' Rt	896.85'	30	5+95.52	9.52' Lt	*896.89'
12	3+70.44	9.44' Lt	*896.79'	31	6+06.54	3.49' Rt	*896.59'
13	3+26.12	14.57' Rt	*896.21'	32	6+10.52	9.48' Lt	*896.95'
14	4+28.12	3.58' Rt	896.44'	33	6+25.52	9.44' Lt	*897.02'
15	4+30.48	9.41' Lt	*896.61'	34	6+36.51	9.01' Lt	*897.09'
16	4+86.12	14.63' Rt	*896.80'	35	6+51.54	2.68' Rt	*896.89'
17	4+88.09	3.63' Rt	896.05'	36	6+62.50	7.69' Lt	*897.19'
18	4+90.26	9.54' Lt	*895.32'	37	6+81.52	2.01' Rt	*897.12'
19	5+16.12	14.64' Rt	*895.86'	38	7+08.66	1.45' Rt	*897.34'
				39	7+08.68	5.36' Lt	*897.38'

*Match Existing Elevation

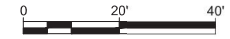

Fargo Intersection Safety

Paving Layout

	STATE	PROJECT NO.	SECTION NO.	SHEET NO.
	ND	HEU-8-984(179)	100	3

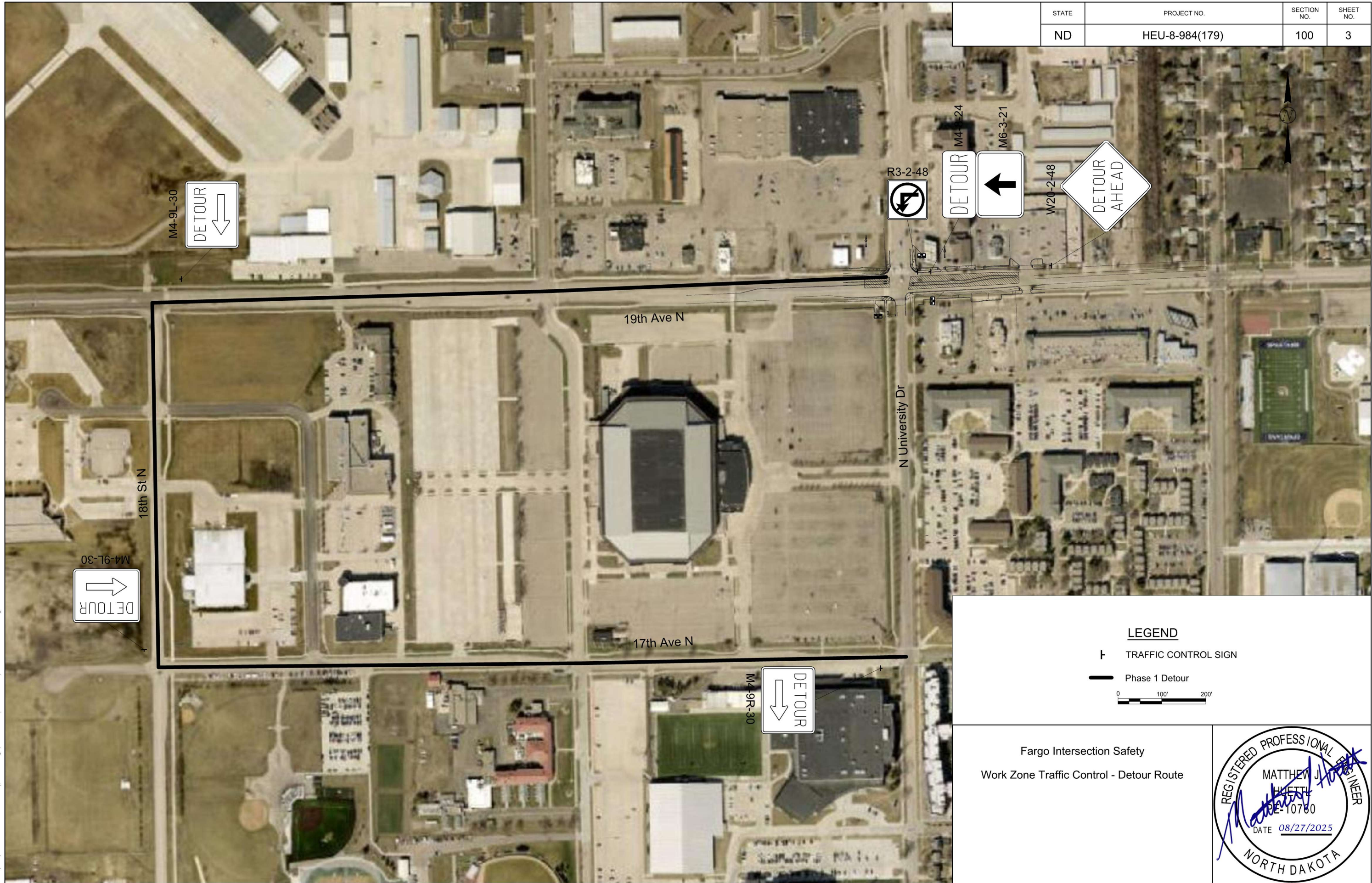

LEGEND

- ⊥ TRAFFIC CONTROL SIGN
- Phase 1 Detour

0 100' 200'

Fargo Intersection Safety
 Work Zone Traffic Control - Detour Route

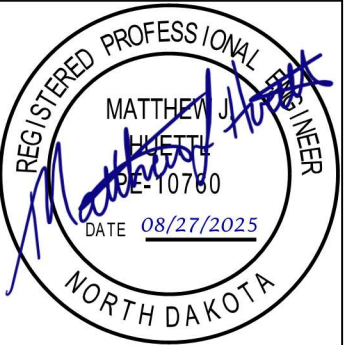



08/27/25 06:35:59AM C:\pwworking\central01\d4311311\100_WorkZone.dwg

STATE	PROJECT NO.	SECTION NO.	SHEET NO.
ND	HEU-8-984(179)	100	4



LEGEND

-  PHASE 1a&b WORK AREA
-  PHASE 1c WORK AREA
-  PHASE 2 WORK AREA

0 20' 40'

Fargo Intersection Safety
Work Zone Traffic Control

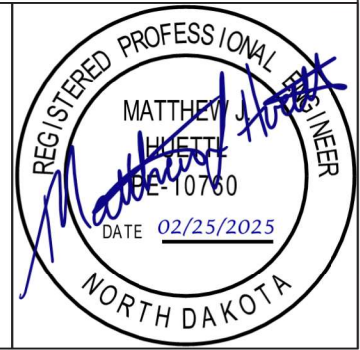

02/19/25 11:30:40AM C:\pwworking\central01\04311311\100_WorkZone.dwg

STATE	PROJECT NO.	SECTION NO.	SHEET NO.
ND	HEU-8-984(179)	100	5



LEGEND

- DELINEATOR DRUM
- ▩ TYPE III BARRICADE
- ┆ TRAFFIC CONTROL SIGN

Fargo Intersection Safety
 Work Zone Traffic Control - Phase 1a & 1b

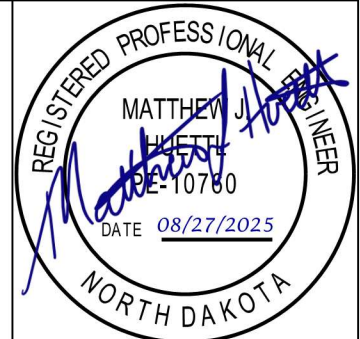

08/27/25 06:37:28AM C:\pwworking\central01\44311311\100_WorkZone.dwg

STATE	PROJECT NO.	SECTION NO.	SHEET NO.
ND	HEU-8-984(179)	100	6



LEGEND

- DELINEATOR DRUM
- ▨ TYPE III BARRICADE
- ⊥ TRAFFIC CONTROL SIGN

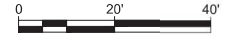

Fargo Intersection Safety
 Work Zone Traffic Control - Phase 1a & 1b

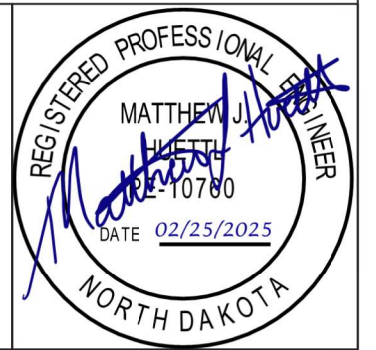

02/19/25 11:31:46AM C:\pwworking\central01\d4311311\100_WorkZone.dwg

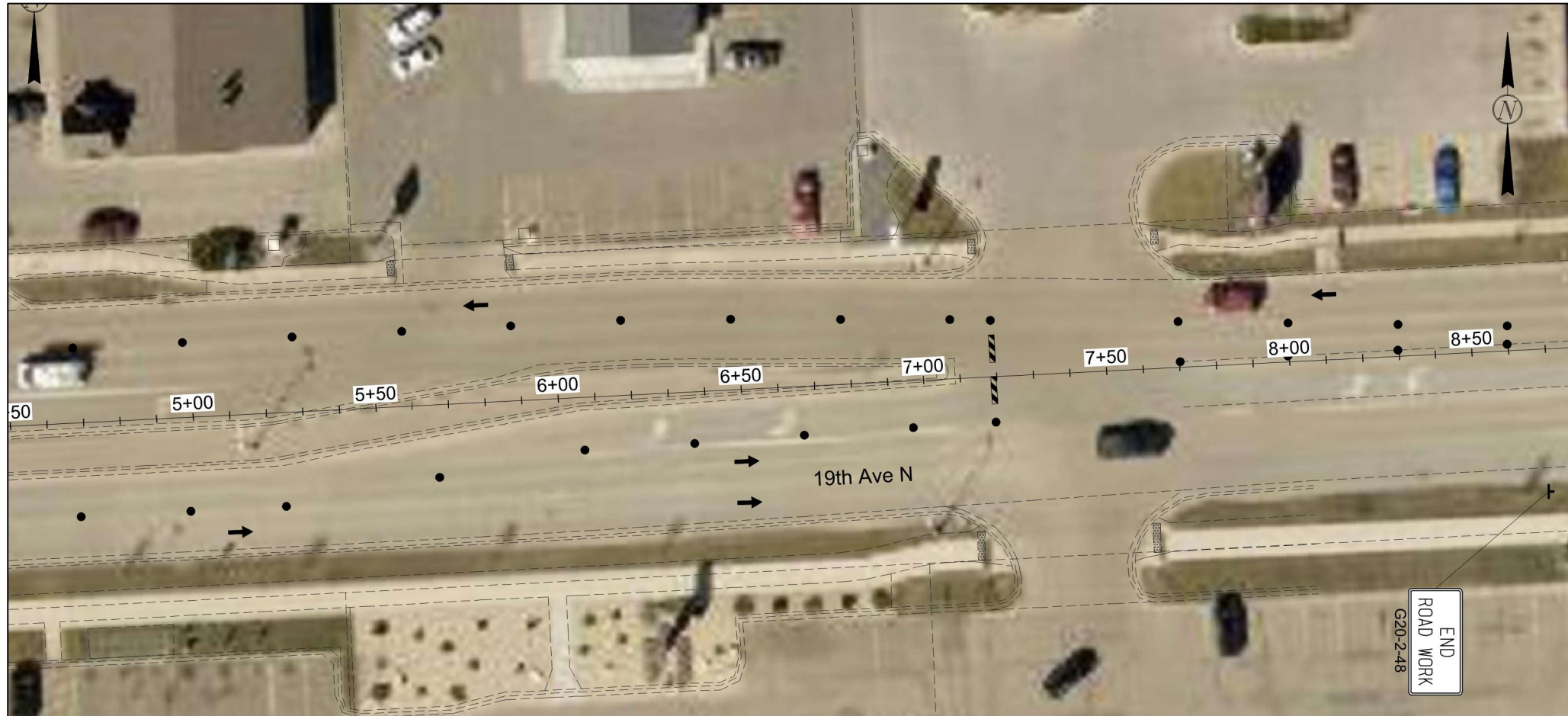

STATE	PROJECT NO.	SECTION NO.	SHEET NO.
ND	HEU-8-984(179)	100	7

LEGEND

- DELINEATOR DRUM
- ▩ TYPE III BARRICADE
- ⊥ TRAFFIC CONTROL SIGN

Fargo Intersection Safety
 Work Zone Traffic Control - Phase 1a & 1b

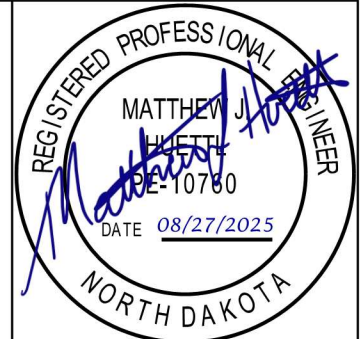

08/27/25 06:38:32AM C:\pwworking\central01\d4311311\100_WorkZone.dwg

STATE	PROJECT NO.	SECTION NO.	SHEET NO.
ND	HEU-8-984(179)	100	8

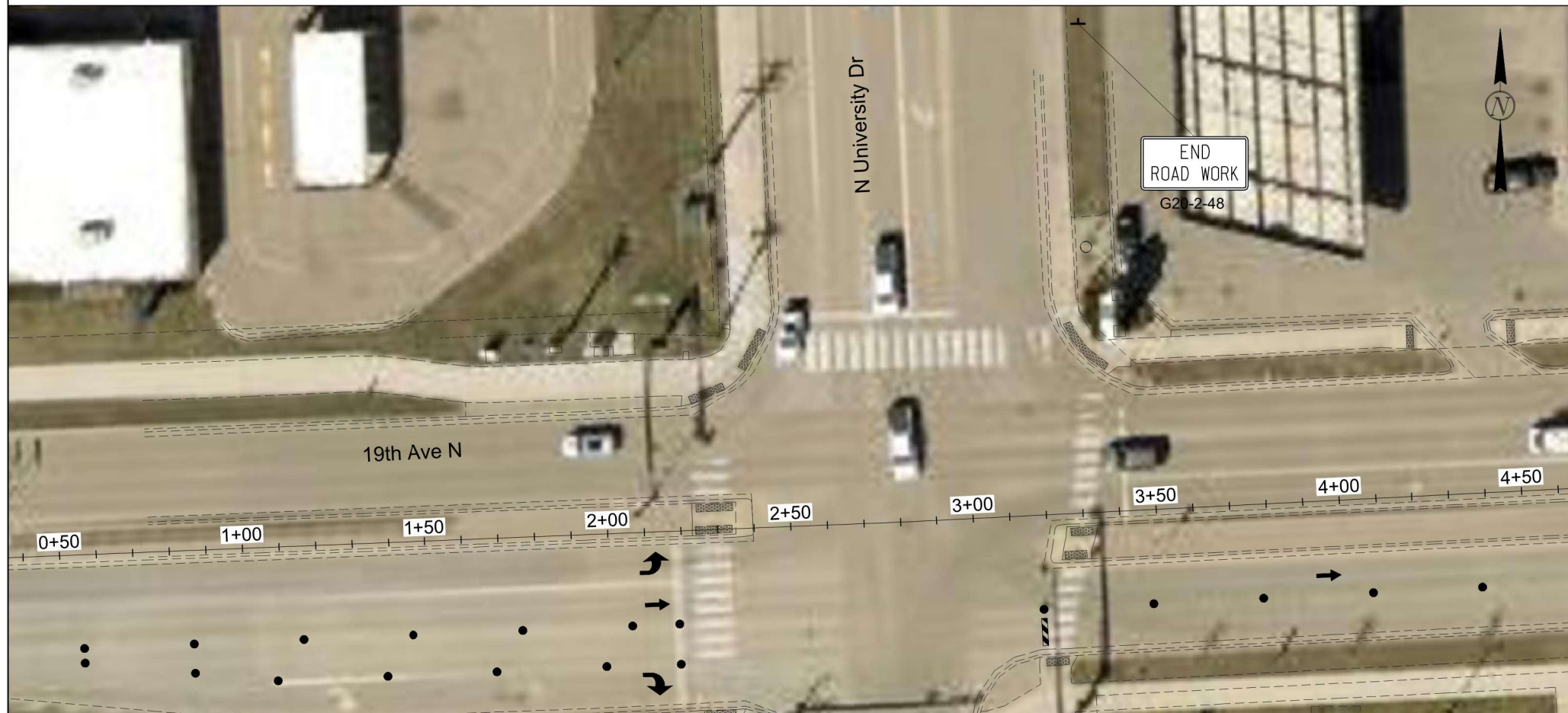

LEGEND

- DELINEATOR DRUM
- ▩ TYPE III BARRICADE
- ⊥ TRAFFIC CONTROL SIGN

0 20' 40'

Fargo Intersection Safety
Work Zone Traffic Control - Phase 1c

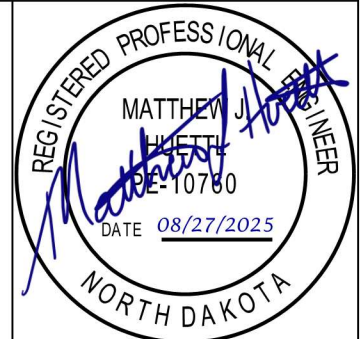

08/27/25 06:39:23AM C:\pwworking\central01\44311311\100_WorkZone.dwg

STATE	PROJECT NO.	SECTION NO.	SHEET NO.
ND	HEU-8-984(179)	100	9



LEGEND

- DELINEATOR DRUM
- ▩ TYPE III BARRICADE
- ⊠ TRAFFIC CONTROL SIGN

Fargo Intersection Safety
 Work Zone Traffic Control - Phase 1c

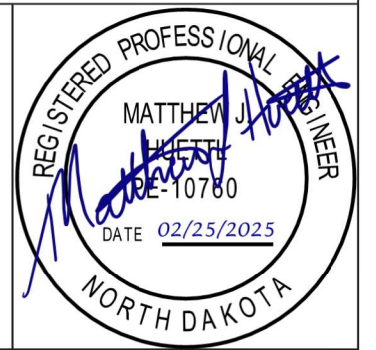

02/19/25 11:33:12AM C:\pwworking\central01\d43311\100_WorkZone.dwg

	STATE	PROJECT NO.	SECTION NO.	SHEET NO.
	ND	HEU-8-984(179)	100	10

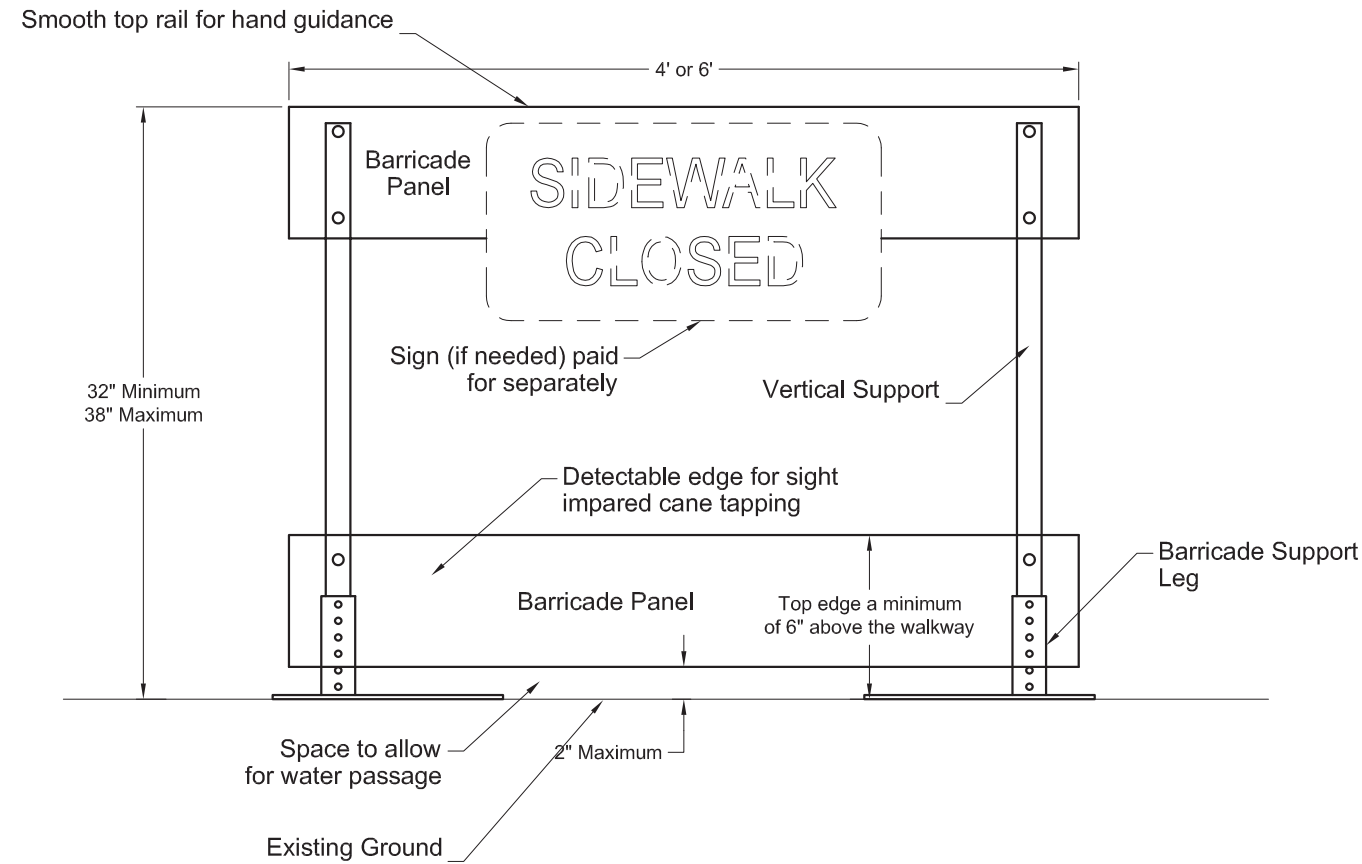

Front View

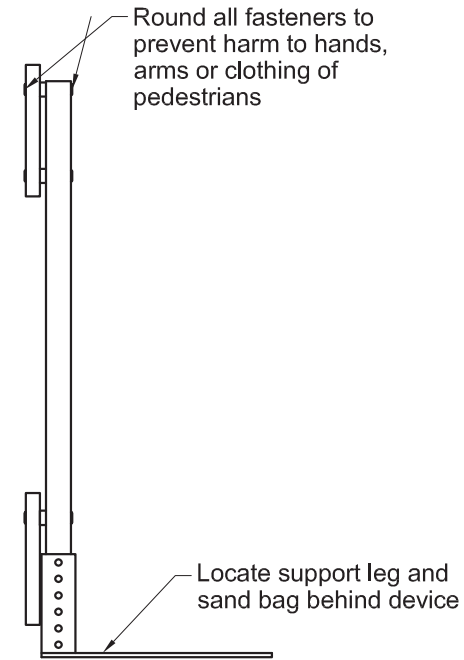

End View

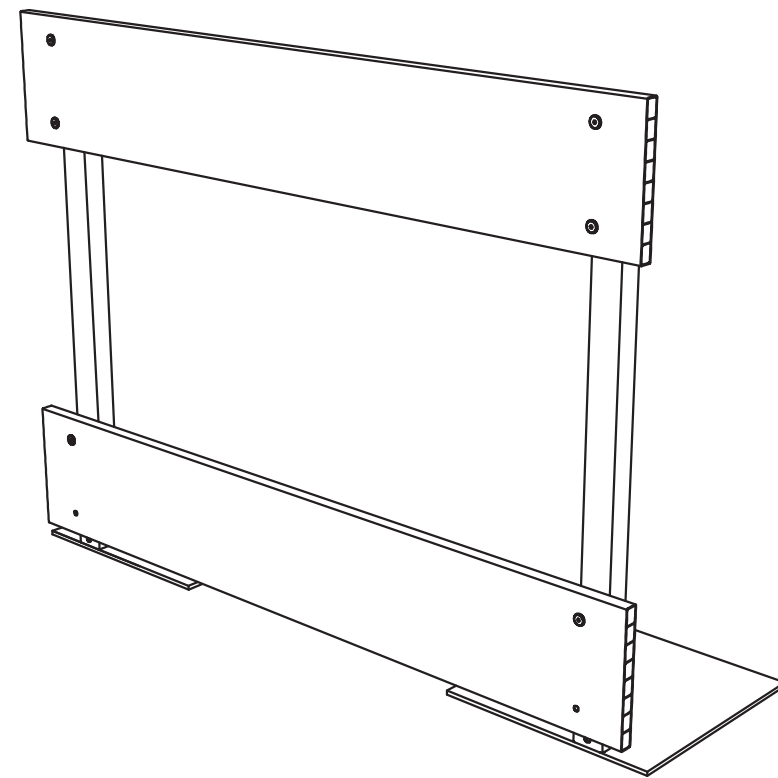

Perspective View

NOTES:

Sidewalk Barricades

1. Provide self standing sidewalk barricade with no supports extending into the pedestrians path.
2. Use orange or orange and white diagonal striped barricade panels contrasting with the walkway surface.
3. Provide ADA compliant and NCHRP 350 or Mash Test Level 3 (TL3) approved sidewalk barricades.
4. Include all costs to furnish, maintain and remove sidewalk barricades in the price bid for "Sidewalk Barricade".

Fargo Intersection Safety
Sidewalk Barricade



	STATE	PROJECT NO.	SECTION NO.	SHEET NO.
	ND	HEU-8-984(179)	100	11

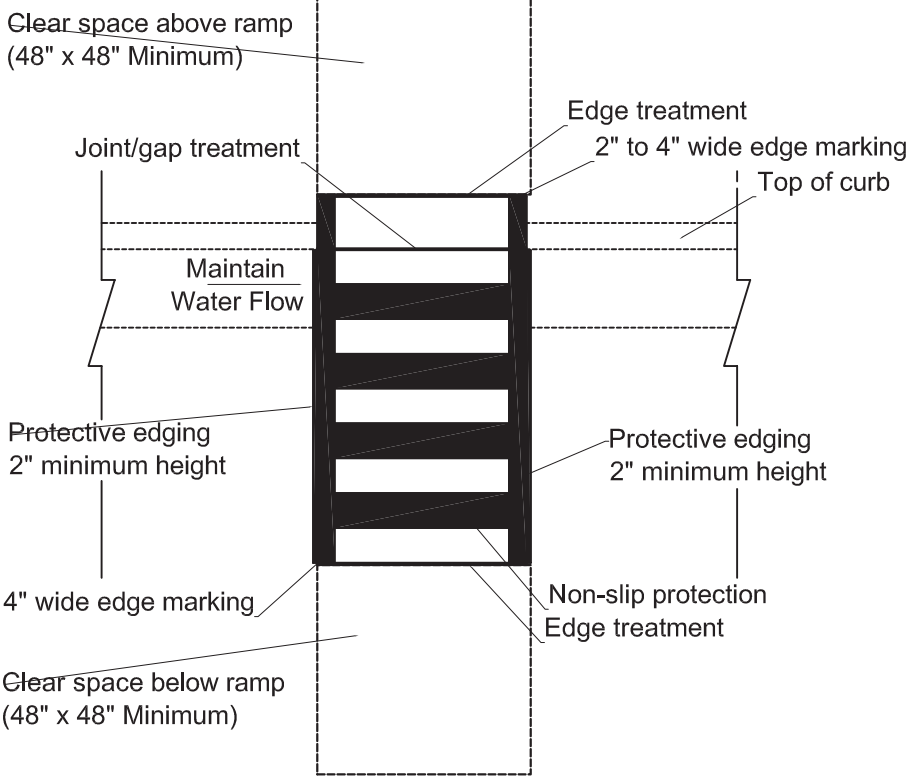

Top View

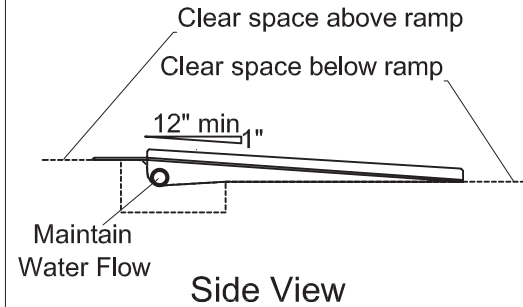

Side View

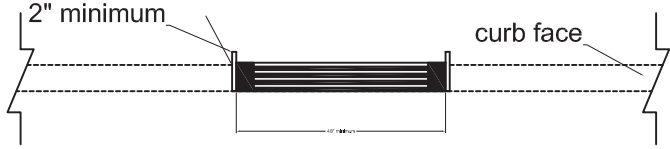

Front View

Temporary Perpendicular Curb Ramp

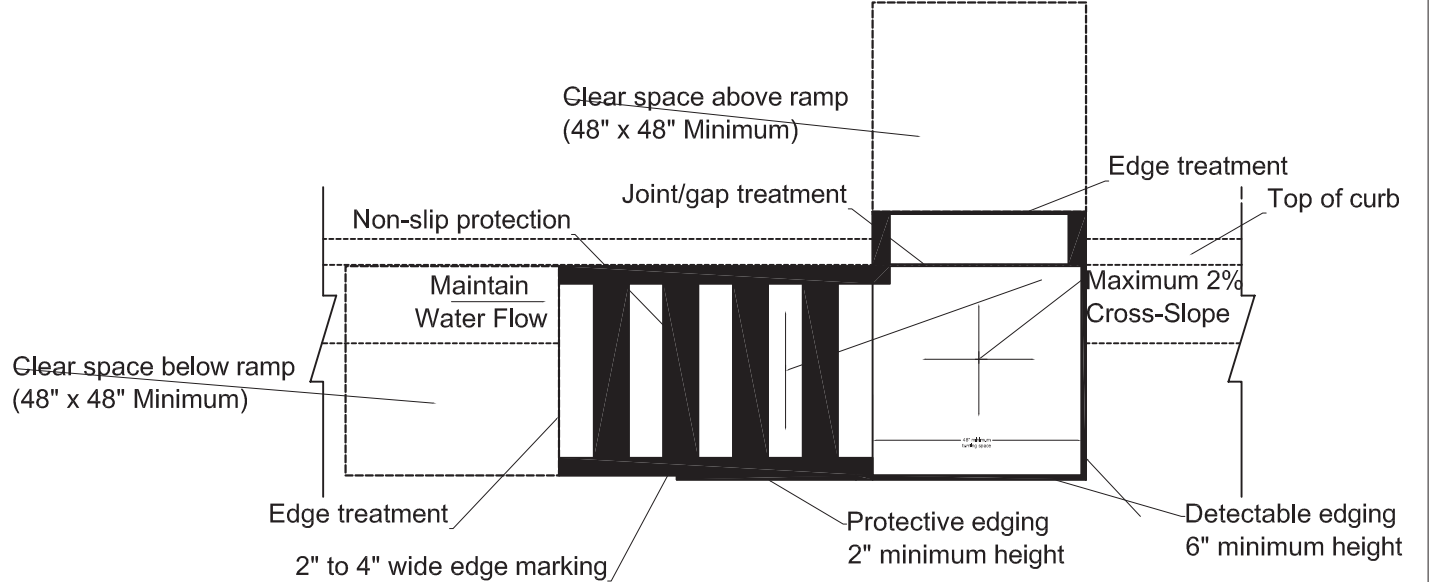

Top View

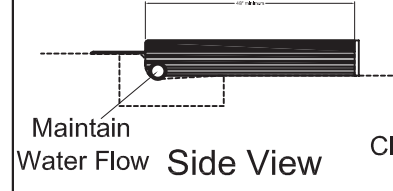

Side View

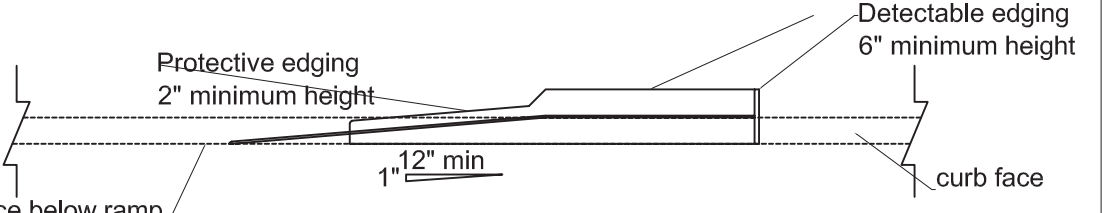

Front View

Temporary Parallel Curb Ramp

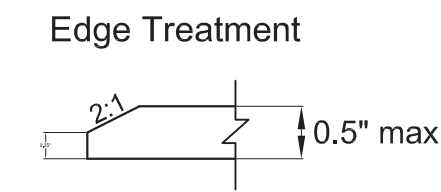

Maximum Surface Height Change Detail

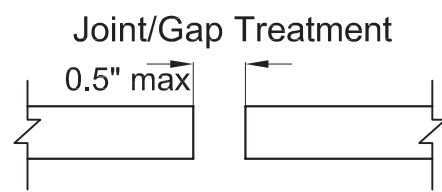

Maximum Width Lateral Joints or Gaps

Fargo Intersection Safety
Temporary Pedestrian Curb Ramp Details

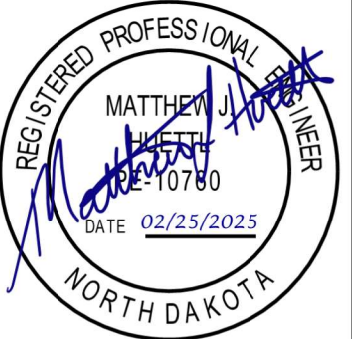

STATE	PROJECT NO.	SECTION NO.	SHEET NO.
ND	HEU-8-984(179)	100	12

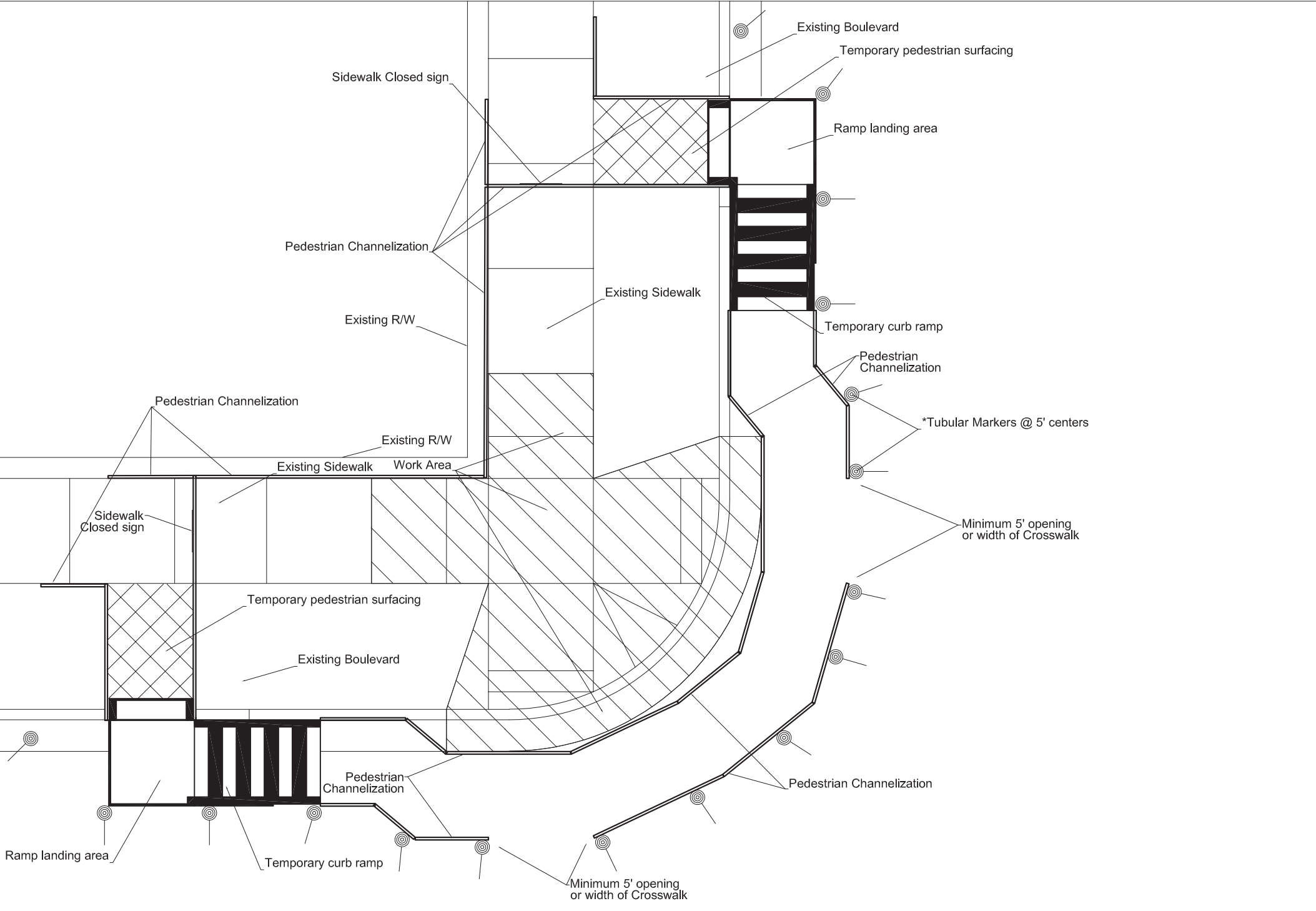

*NOTE: Eliminate tubular markers if pedestrian channelization is retro-reflective

Fargo Intersection Safety
Temporary Pedestrian Access Route

STATE	PROJECT NO.	SECTION NO.	SHEET NO.
ND	HEU-8-984(179)	100	13



LEGEND

- PEDESTRIAN CHANNELIZATION
- TUBULAR MARKER
- ⊠ TEMPORARY PEDESTRIAN SURFACING
- DELINEATOR DRUM
- ▨ SIDEWALK BARRICADE
- † TRAFFIC CONTROL SIGN

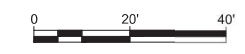

Fargo Intersection Safety
Pedestrian Traffic Control - Phase 2a

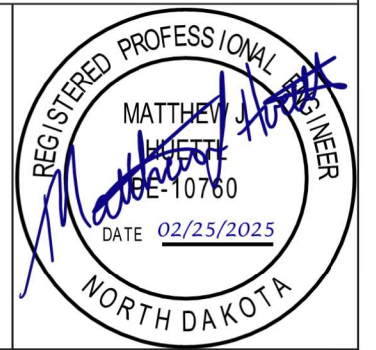

02/19/25 11:35:07AM C:\pwworking\central01\d4311311\100_WorkZone.dwg

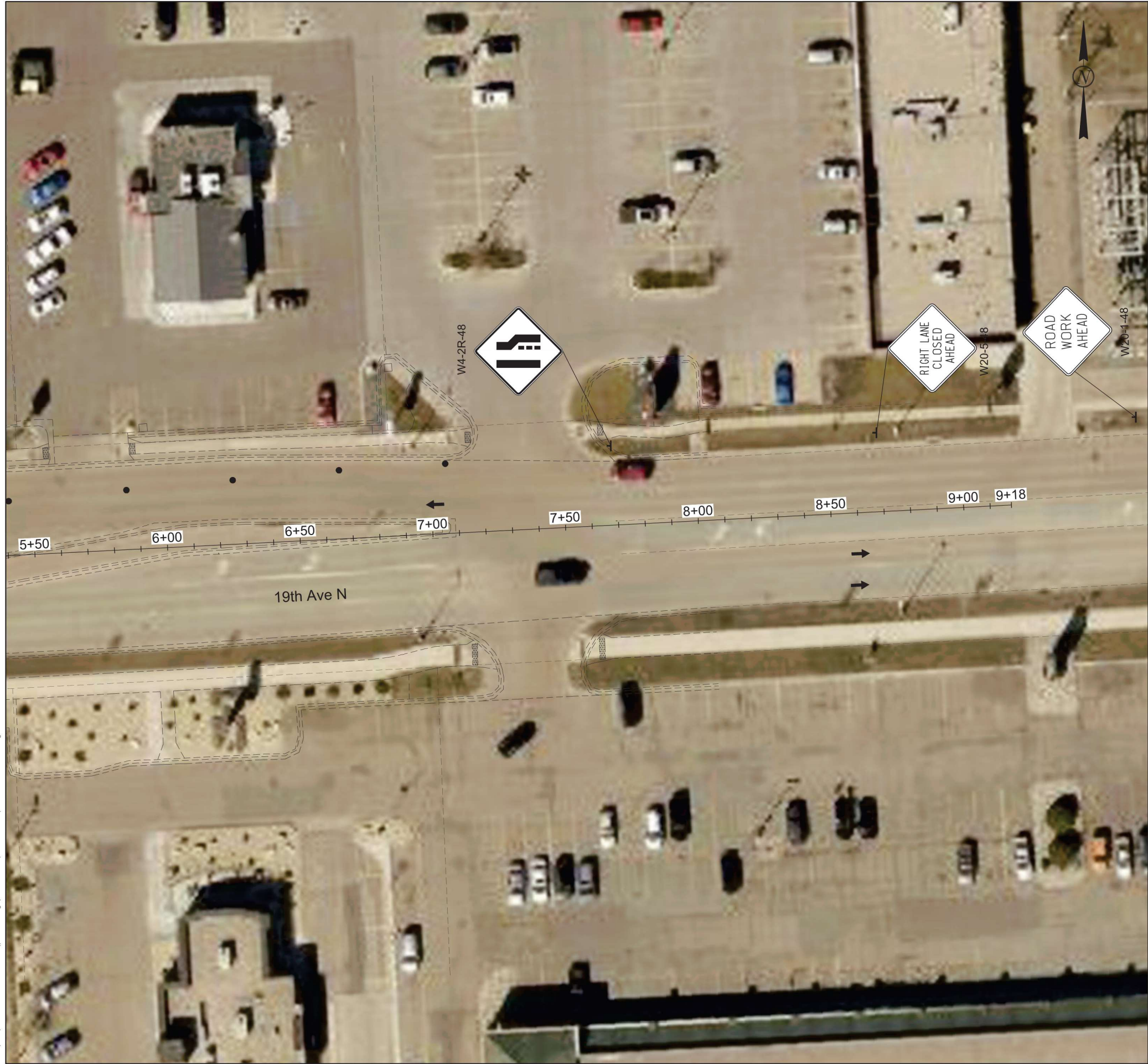

STATE	PROJECT NO.	SECTION NO.	SHEET NO.
ND	HEU-8-984(179)	100	14

LEGEND

- PEDESTRIAN CHANNELIZATION
- TUBULAR MARKER
- ⊠ TEMPORARY PEDESTRIAN SURFACING
- DELINEATOR DRUM
- ▨ SIDEWALK BARRICADE
- ⊣ TRAFFIC CONTROL SIGN

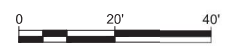

02/19/25 11:35:32AM C:\pwworking\central01\d4311311\100_WorkZone.dwg



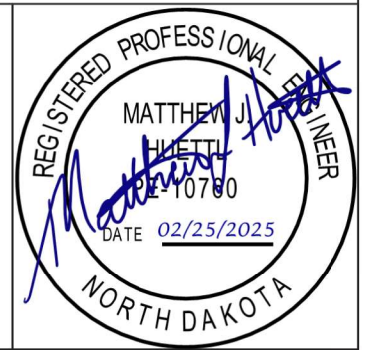



Fargo Intersection Safety
Pedestrian Traffic Control - Phase 2a



STATE	PROJECT NO.	SECTION NO.	SHEET NO.
ND	HEU-8-984(179)	100	15



LEGEND

-  PEDESTRIAN CHANNELIZATION
-  TUBULAR MARKER
-  TEMPORARY PEDESTRIAN SURFACING
-  DELINEATOR DRUM
-  SIDEWALK BARRICADE
-  TRAFFIC CONTROL SIGN

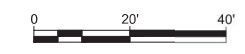

Fargo Intersection Safety
Pedestrian Traffic Control - Phase 2b

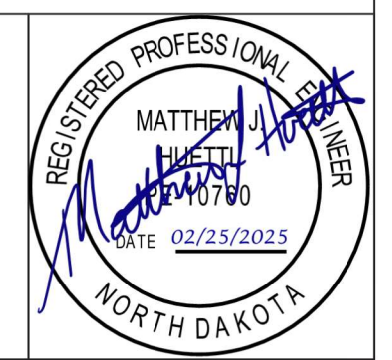



STATE	PROJECT NO.	SECTION NO.	SHEET NO.
ND	HEU-8-984(179)	100	16

LEGEND

- PEDESTRIAN CHANNELIZATION
- TUBULAR MARKER
- ⊠ TEMPORARY PEDESTRIAN SURFACING
- DELINEATOR DRUM
- ▨ SIDEWALK BARRICADE
- ⊣ TRAFFIC CONTROL SIGN

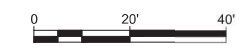

Fargo Intersection Safety
Pedestrian Traffic Control - Phase 2b

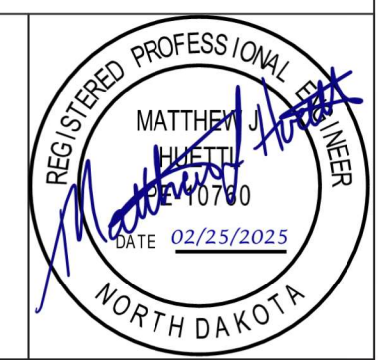

02/19/25 11:36:18AM C:\pwworking\central01\d4311311\100_WorkZone.dwg

02/19/25 11:36:38AM C:\pwworking\central01\d4311311\100_WorkZone.dwg



STATE	PROJECT NO.	SECTION NO.	SHEET NO.
ND	HEU-8-984(179)	100	17

LEGEND

- PEDESTRIAN CHANNELIZATION
- TUBULAR MARKER
- ☒ TEMPORARY PEDESTRIAN SURFACING
- DELINEATOR DRUM
- ▨ SIDEWALK BARRICADE
- ⊣ TRAFFIC CONTROL SIGN



Fargo Intersection Safety
 Pedestrian Traffic Control - Phase 2c

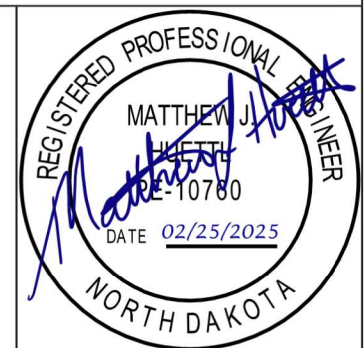

STATE	PROJECT NO.	SECTION NO.	SHEET NO.
ND	HEU-8-984(179)	100	18



LEGEND

- PEDESTRIAN CHANNELIZATION
- TUBULAR MARKER
- ⊠ TEMPORARY PEDESTRIAN SURFACING
- DELINEATOR DRUM
- ▨ SIDEWALK BARRICADE
- † TRAFFIC CONTROL SIGN

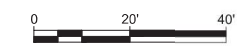

Fargo Intersection Safety
Pedestrian Traffic Control - Phase 2c

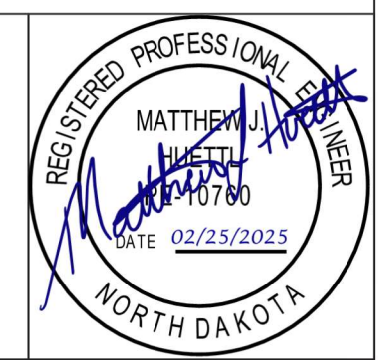

STATE	PROJECT NO.	SECTION NO.	SHEET NO.
N.D.	HEU-8-984(179)	110	1

Station / RP	Sign No.	Assembly No.	Flat Sheet For Signs		Sign Support Length				Vert Clearance FT	Support Size	Max Post Len LF	Sleeve Length				Sleeve Size	Anchor EA	Anchor LF	Anchor Size	Reset Sign Panel EA	Reset Sign Support EA	Break-Away EA	Comments
			IV SF	XI SF	1st LF	2nd LF	3rd LF	4th LF				1st LF	2nd LF	3rd LF	4th LF								
1+90 Lt mdn	SA-A		4.0		13.7				7.0	2.5 x 2.5 10 ga	14.2					1	4	3 x 3 7 ga	1		1		
5+57 Lt		14	4.0		11.7				7.0	2 x 2 12 ga	13.0					1	4	2.25 x 2.25 12 ga					
Sub Total			0.0	8.0	Total	25.4									Total	8.0			1	0	1		
Grand Total			0.0	8.0	Total	25.4									Total	8	0		1	0	1		

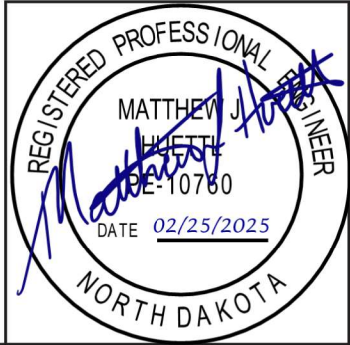

Sign Summary
 Perforated Tube
 Fargo Intersection Safety

STATE	PROJECT NO.	SECTION NO.	SHEET NO.
ND	HEU-8-984(179)	110	2

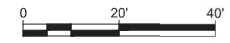
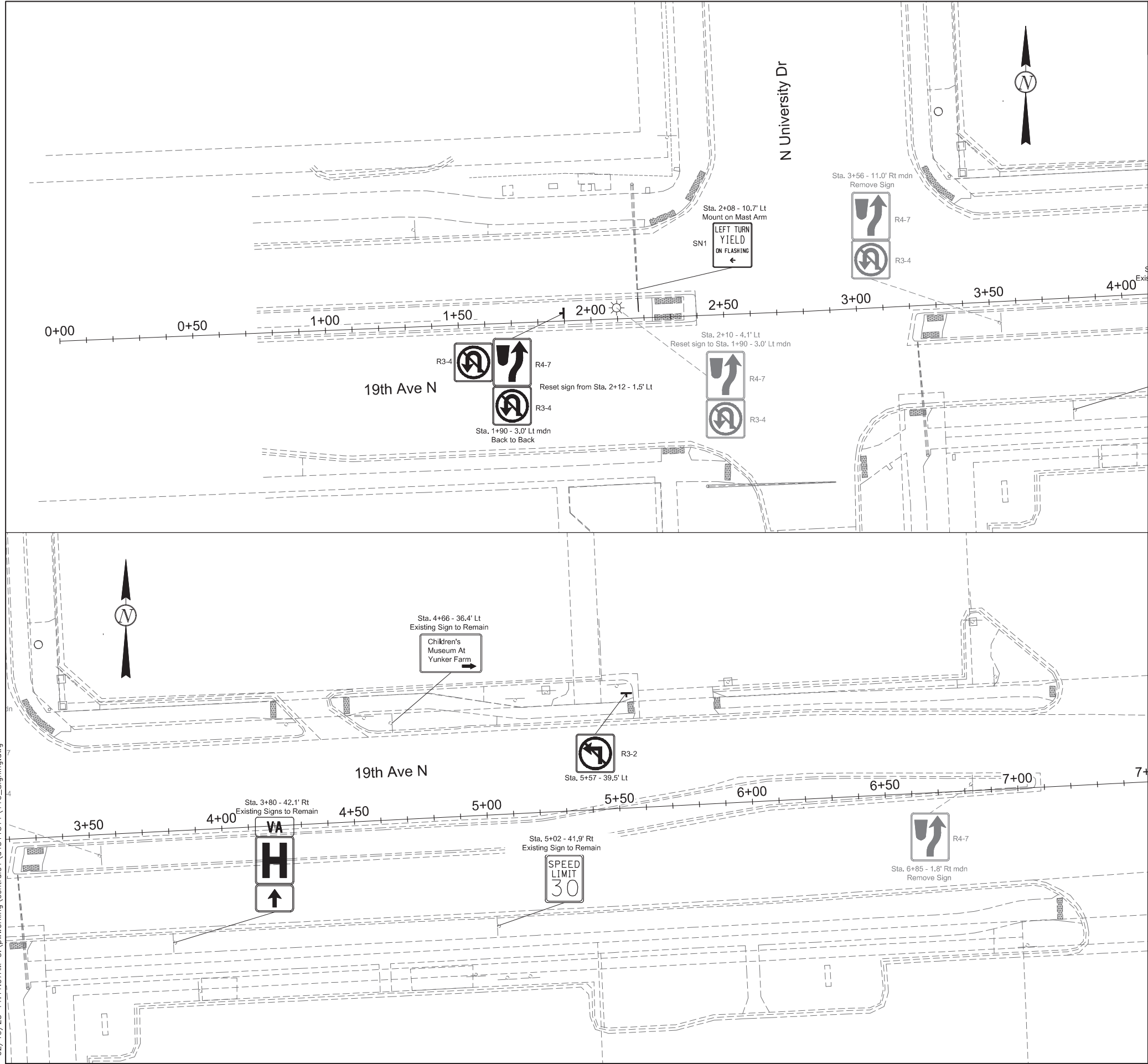

02/19/25 11:41:07AM C:\pwworking\central01\d43111311\110_Signing.dwg

Fargo Intersection Safety
Signing Layout

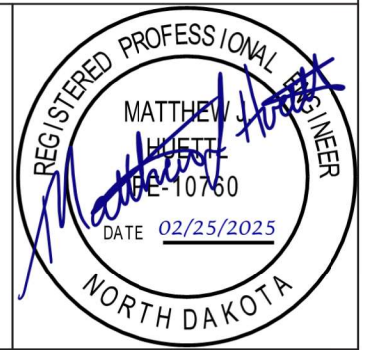

STATE	PROJECT NO.	SECTION NO.	SHEET NO.
ND	HEU-8-984(179)	110	3

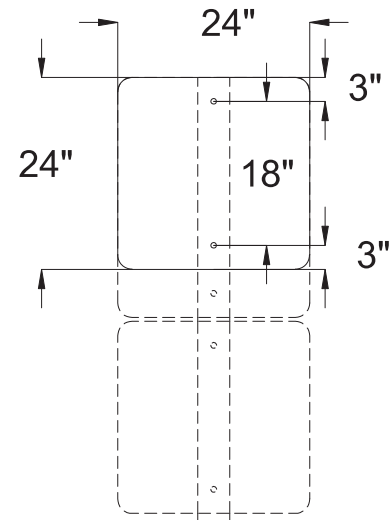

Special Assembly A - Front
 Design Area = 13.00 SF
 Pay Area = 4.00 SF

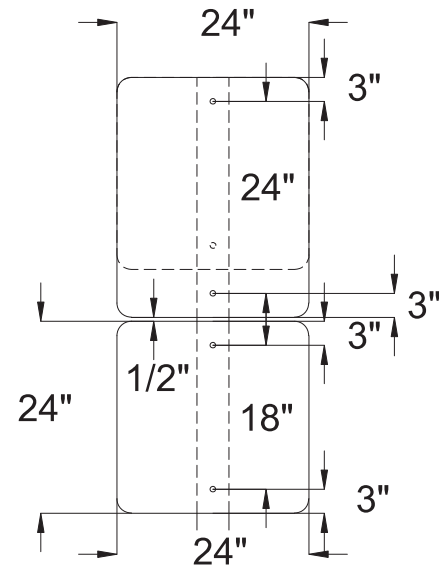

Special Assembly A - Back
 Design Area = 13.00 SF
 Pay Area = 4.00 SF

<p>Fargo Intersection Safety Special Assemblies</p>	
--	--

STATE	PROJECT NO.	SECTION NO.	SHEET NO.
ND	HEU-8-984(179)	120	1

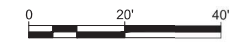
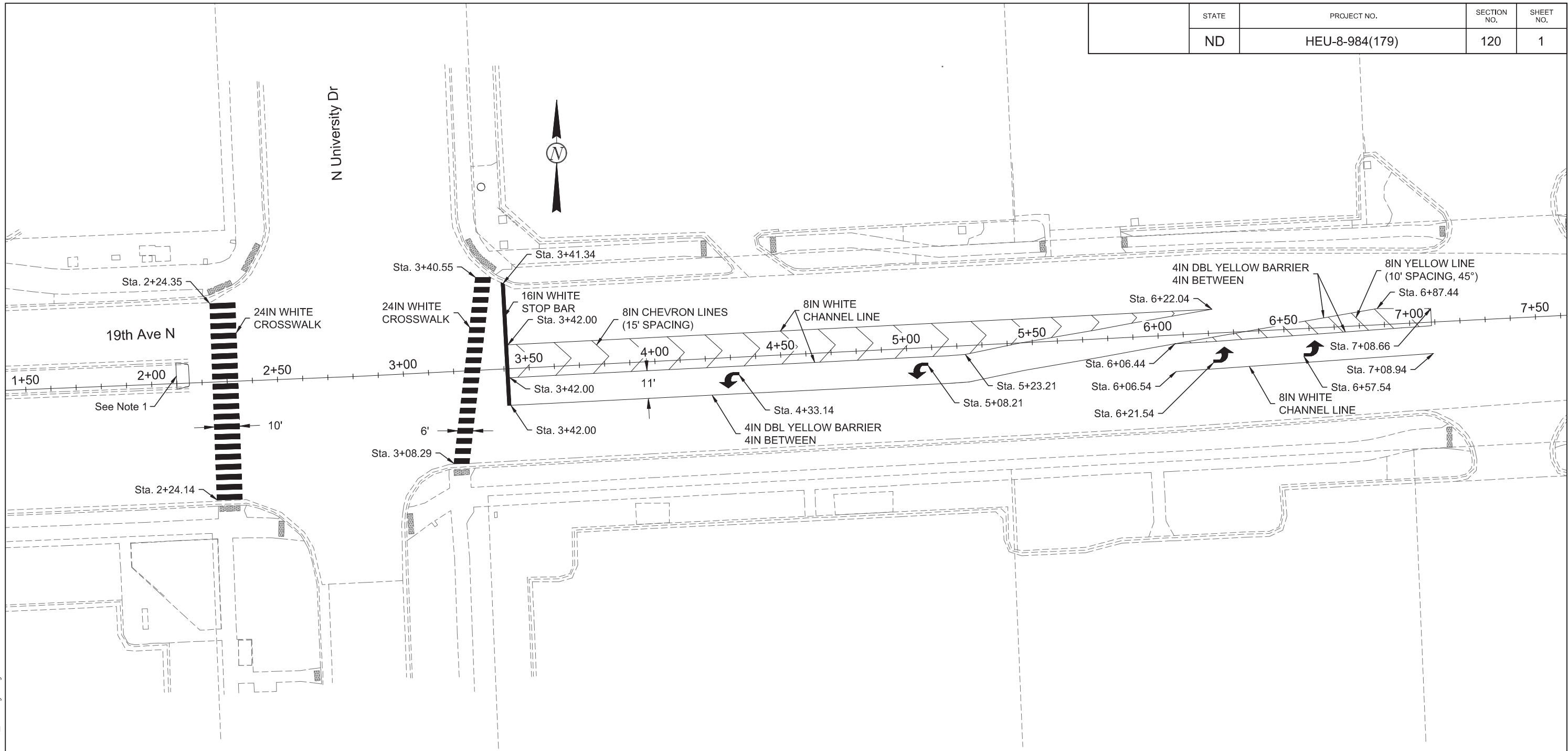

Note 1: Concrete Median Painting is incidental to bid item "CONCRETE MEDIAN NOSE PAVING".

Fargo Intersection Safety Pavement Markings	
--	--

STATE	PROJECT NO.	SECTION NO.	SHEET NO.
ND	HEU-8-984(179)	140	1

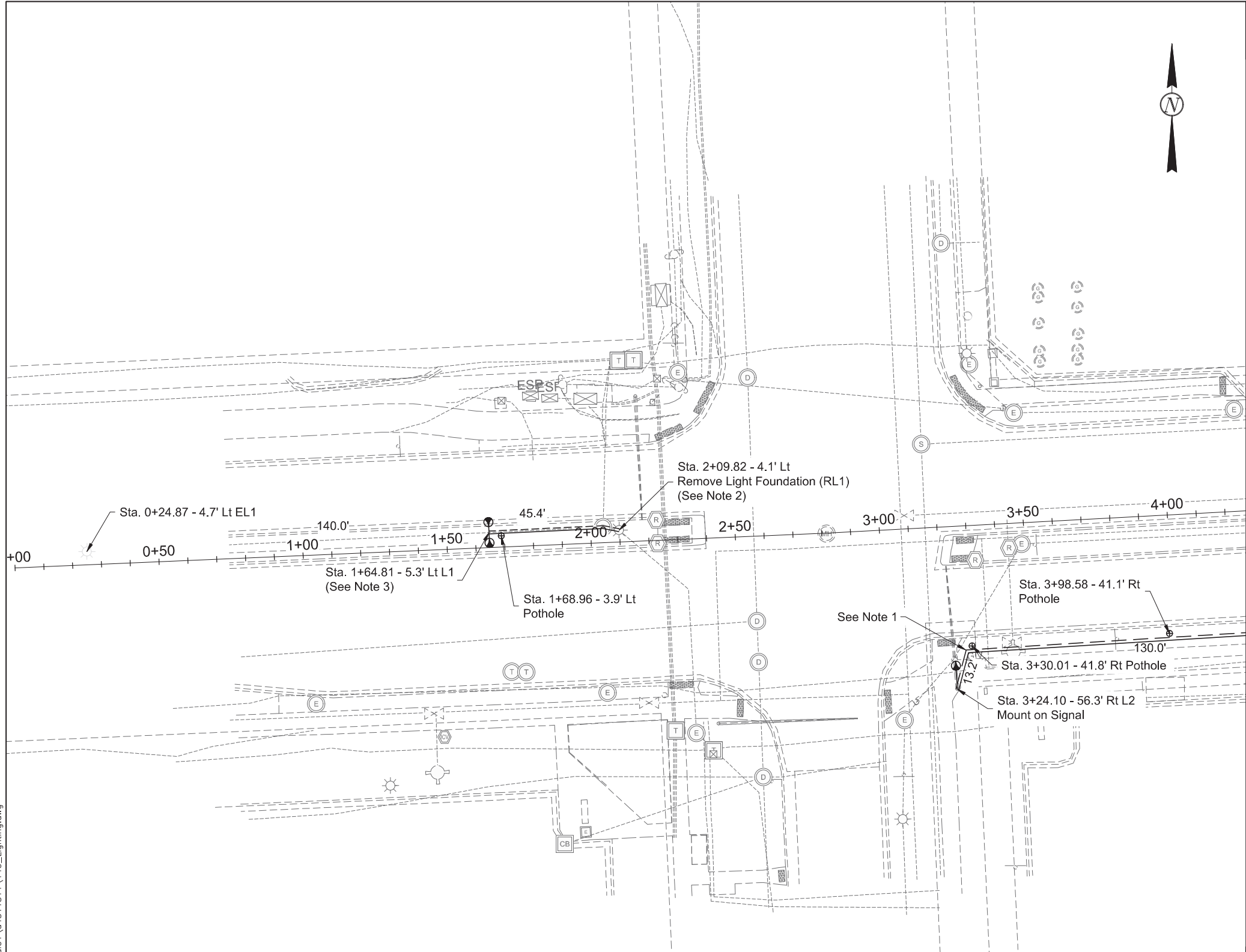

LEGEND

- ⊕ Pothole
- Pull Box
- ☀ Existing Street Light
- Type 'A' LED Lum, on 30' STD
- Conductor
- 1.5" Innerduct
- Existing 1.5" Innerduct & conductor

Note 1: Pothole and locate existing innerduct.

Note 2: Splice existing conduit. Remove and salvage existing wire. Remove existing concrete light base, and install a conduit in place of base. Patch concrete where base is removed.

Note 3: Splice existing conduit and add new foundation and light pole.

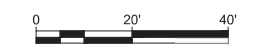

Fargo Intersection Safety
Lighting Layout

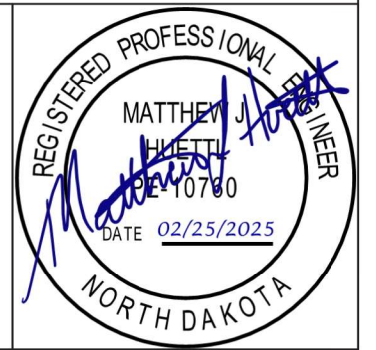

STATE	PROJECT NO.	SECTION NO.	SHEET NO.
ND	HEU-8-984(179)	140	2

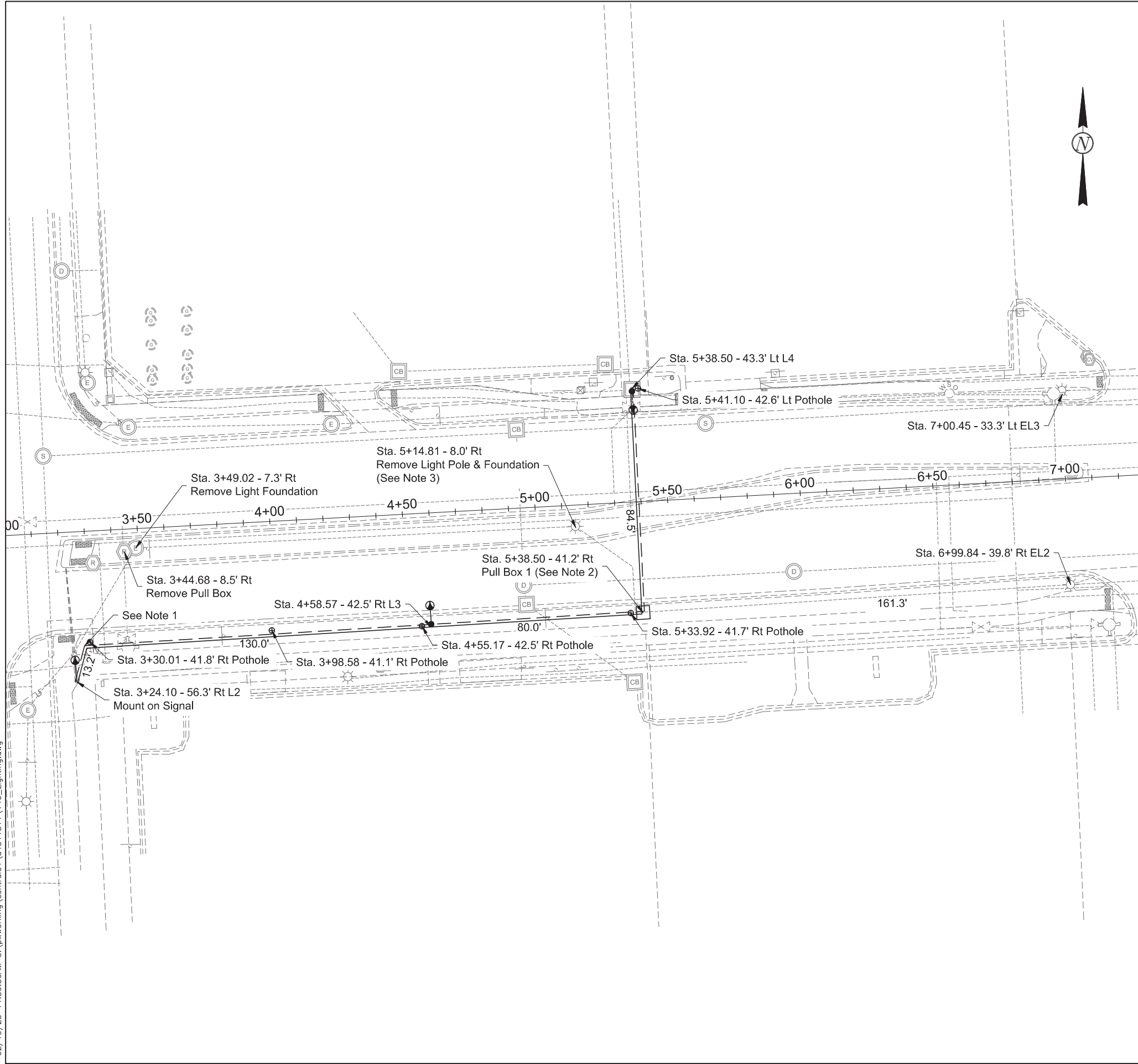

LEGEND

- ⊕ Pothole
- Pull Box
- ☀ Existing Street Light
- Type 'A' LED Lum, on 30' STD
- Conductor
- 1.5" Innerduct
- - - Existing 1.5" Innerduct & conductor

Note 1: Pothole and locate existing innerduct

Note 2: Pothole and locate existing innerduct. Install new pull box. Connect existing conductor with circuit 2. (Lights L2, L3, and L4).

Note 3: Return pole and fixture to City.

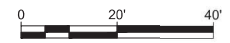

Fargo Intersection Safety
Lighting Layout

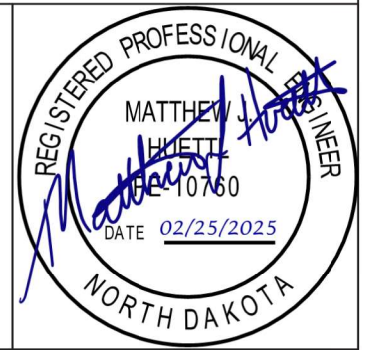

STATE	PROJECT NO.	SECTION NO.	SHEET NO.
ND	HEU-8-984(179)	140	3

LEGEND

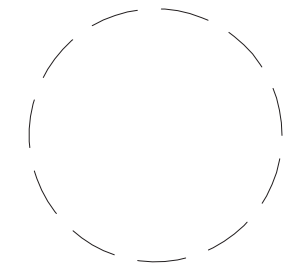

Feed Point

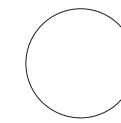

Light Standard



Pull Box



Roadway LED Luminaire



Existing Roadway LED Luminaire

L7

Light Standard Number



Ground Conductor



Phase 2 Conductor



Ground Conductor

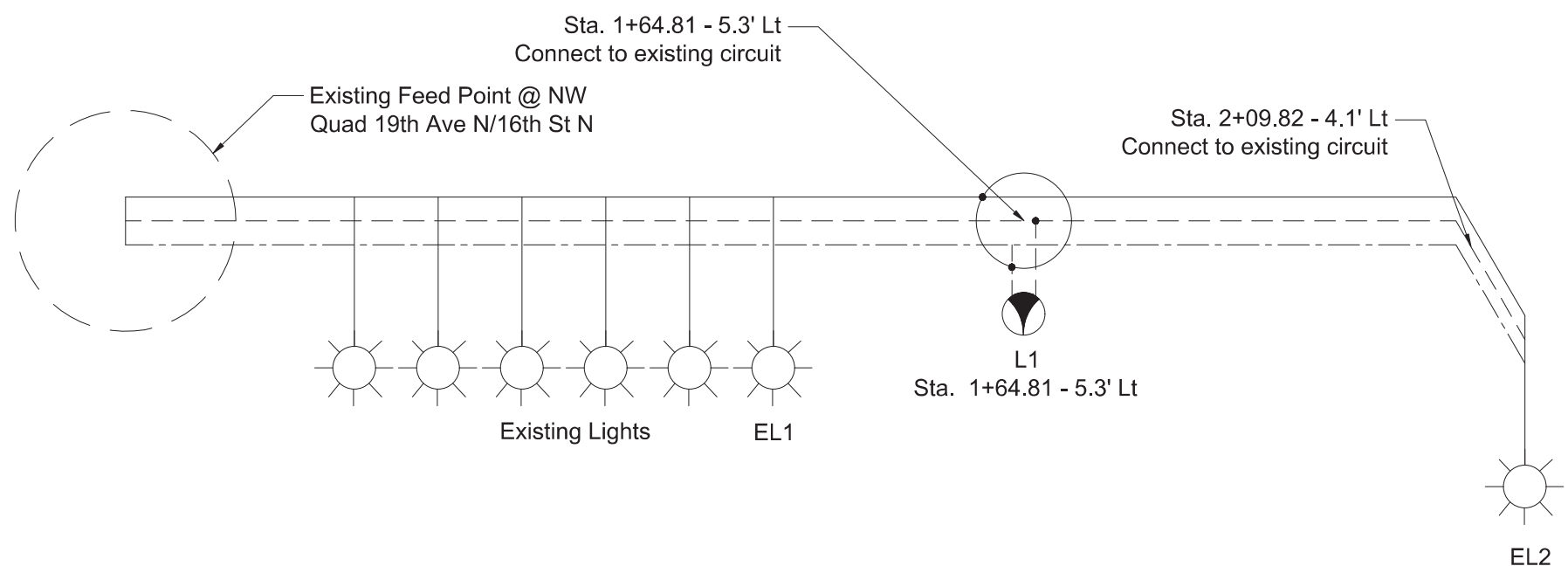





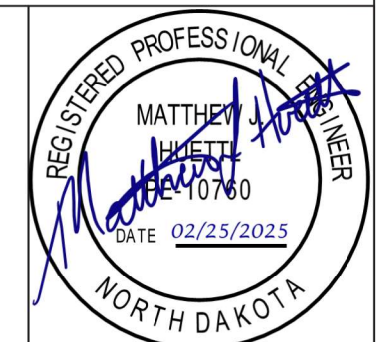

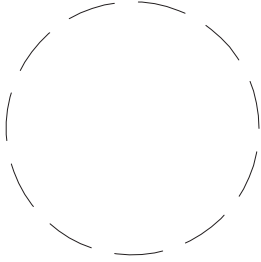
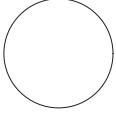

02/19/25 11:51:17AM C:\pwworking\central01\d4311311\140_Lighting.dwg

Fargo Intersection Safety
Lighting Layout - Circuit 1



STATE	PROJECT NO.	SECTION NO.	SHEET NO.
ND	HEU-8-984(179)	140	4

LEGEND

-  Feed Point
-  Light Standard
-  Pull Box
-  Roadway LED Luminaire
-  Existing Roadway LED Luminaire
-  Light Standard Number
-  Ground Conductor
-  Phase 2 Conductor
-  Ground Conductor

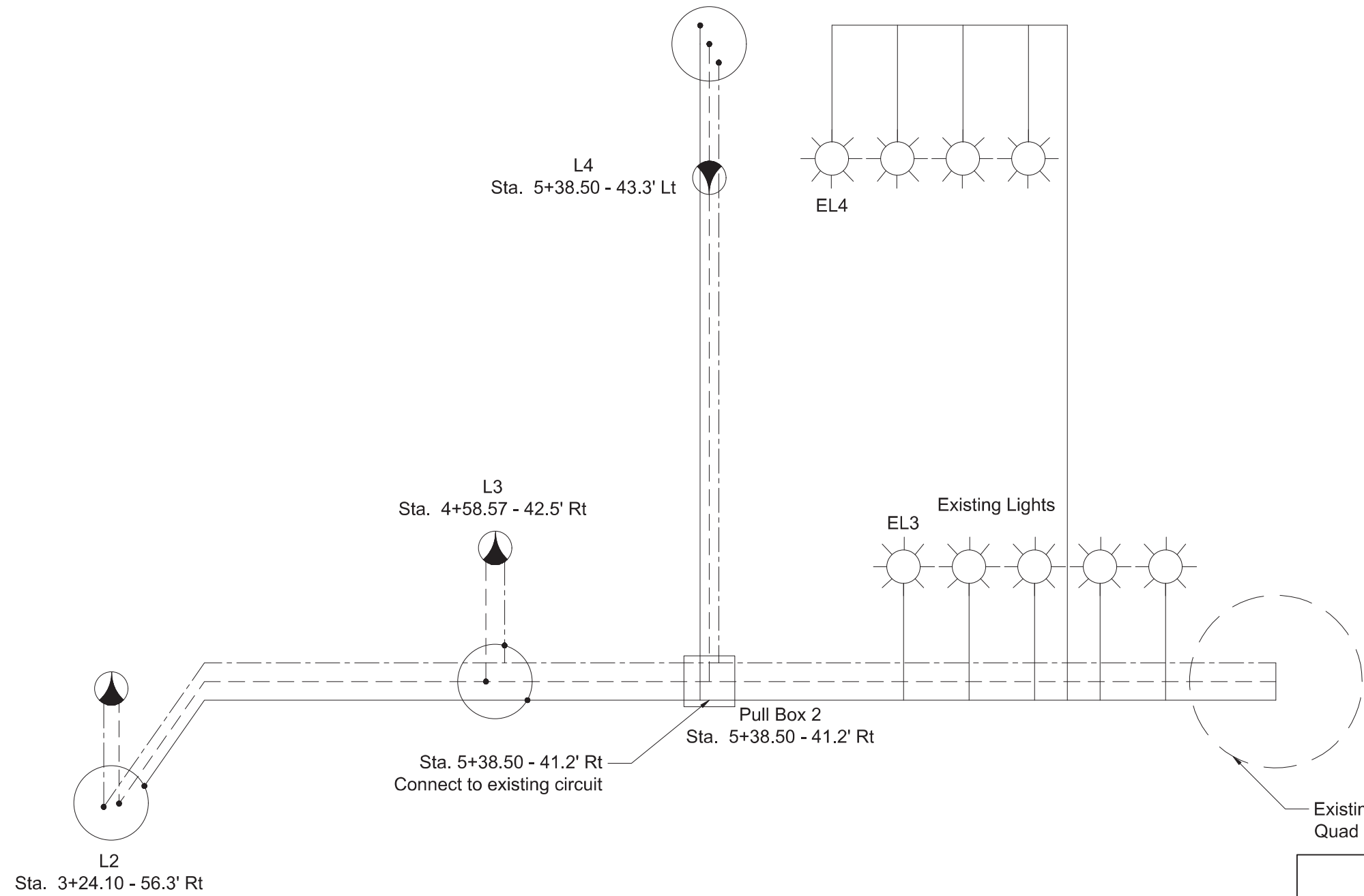

Existing Feed Point @ SE
Quad 19th Ave N/10th St N

Fargo Intersection Safety
Lighting Layout - Circuit 2

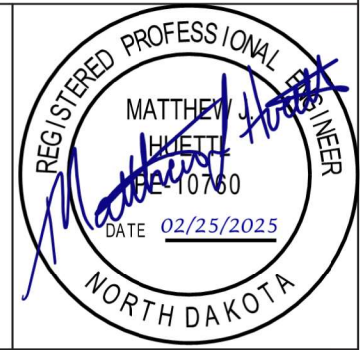

STATION OFFSET	STATION ALIGNMENT	REMOVALS
2+09.82 - 4.1' Lt	19th Ave N	Remove Light Foundation
3+44.68 - 8.5' Rt	19th Ave N	Remove Pull Box
3+49.02 - 7.3' Rt	19th Ave N	Remove Light Foundation
5+14.81 - 8.0' Rt	19th Ave N	Remove Light Pole
5+14.81 - 8.0' Rt	19th Ave N	Remove Light Foundation

LIGHTING REMOVAL QUANTITIES (A)	
REMOVE LIGHT POLE	REMOVE LIGHT FOUNDATION
EA	EA
1	3

(A) These items shall not be bid separately but shall be included in the bid item "REMOVE LIGHTING SYSTEM".

Lighting Cable and Conduit Schedule - Circuit 1					
Assembly #	Station	Conduit Runs		Cable Runs	
		LF	DIA (IN)	LF	Type
Light 1 to RL1	1+64.81 - 5.3' Lt 2+09.82 - 4.1' Lt	45.4	1.5	53.4	3 No. 6 USE

Lighting Cable and Conduit Schedule - Circuit 2					
Assembly #	Station	Conduit Runs		Cable Runs	
		LF	DIA (IN)	LF	Type
Light 1 to Light 2	3+24.10 - 56.3' Rt 4+58.57 - 42.5' Rt	143.2	1.5	151.2	3 No. 6 USE
Light 2 to Pull Box 1	4+58.57 - 42.5' Rt to 5+38.50 - 41.2' Rt	80.0	1.5	88.0	3 No. 6 USE
Pull Box to Light 3	5+38.50 - 41.2' Rt 5+38.50 - 43.3' Lt	84.5	1.5	92.5	3 No. 6 USE

LIGHT STANDARDS							
No.	Station	Lumens	Circuit	Mounting	Mounting Ht	Mast Arm	Breakaway
1	1+64.81 - 5.3' Lt	12,185	1	Double	30'	6'	Bkway
2	3+24.10 - 56.3' Rt	12,185	2	Single	40'	6'	N/A
3	4+58.57 - 42.5' Rt	12,185	2	Single	30'	6'	Bkway
4	5+38.50 - 43.3' Lt	12,185	2	Single	30'	6'	Bkway

Pull Box	
No.	Station
1	5+38.50 - 41.2' Rt

LIGHTING QUANTITIES (B)				
CONCRETE FOUNDATION - ROADWAY LIGHTING	1.5 IN DIAMETER RIGID CONDUIT	MULTIPLE UNDERGROUND CABLE 3 NO. 6 USE	LT STD ROADWAY 6 FT MA 30 FT MH POLE BREAKAWAY	LED LUMINAIRE - 12,185 LUMENS
EA	LF	LF	EA	EA
3	353.1	385.1	3	5

(B) These items shall not be bid separately but shall be included in the bid item "LIGHTING SYSTEM".

Light Standard Foundation Table	
Description	Foundation Depth
	30' MH Pole - Single Mast Arm

1. Led lighting poles shall be placed in the locations specified on the plans.
2. Any other maker or model shall meet the illuminance criteria and attributed and be approved by the engineer prior to ordering.

Fargo Intersection Safety Lighting Layout	
--	--

STATE	PROJECT NO.	SECTION NO.	SHEET NO.
ND	HEU-8-984(179)	150	1

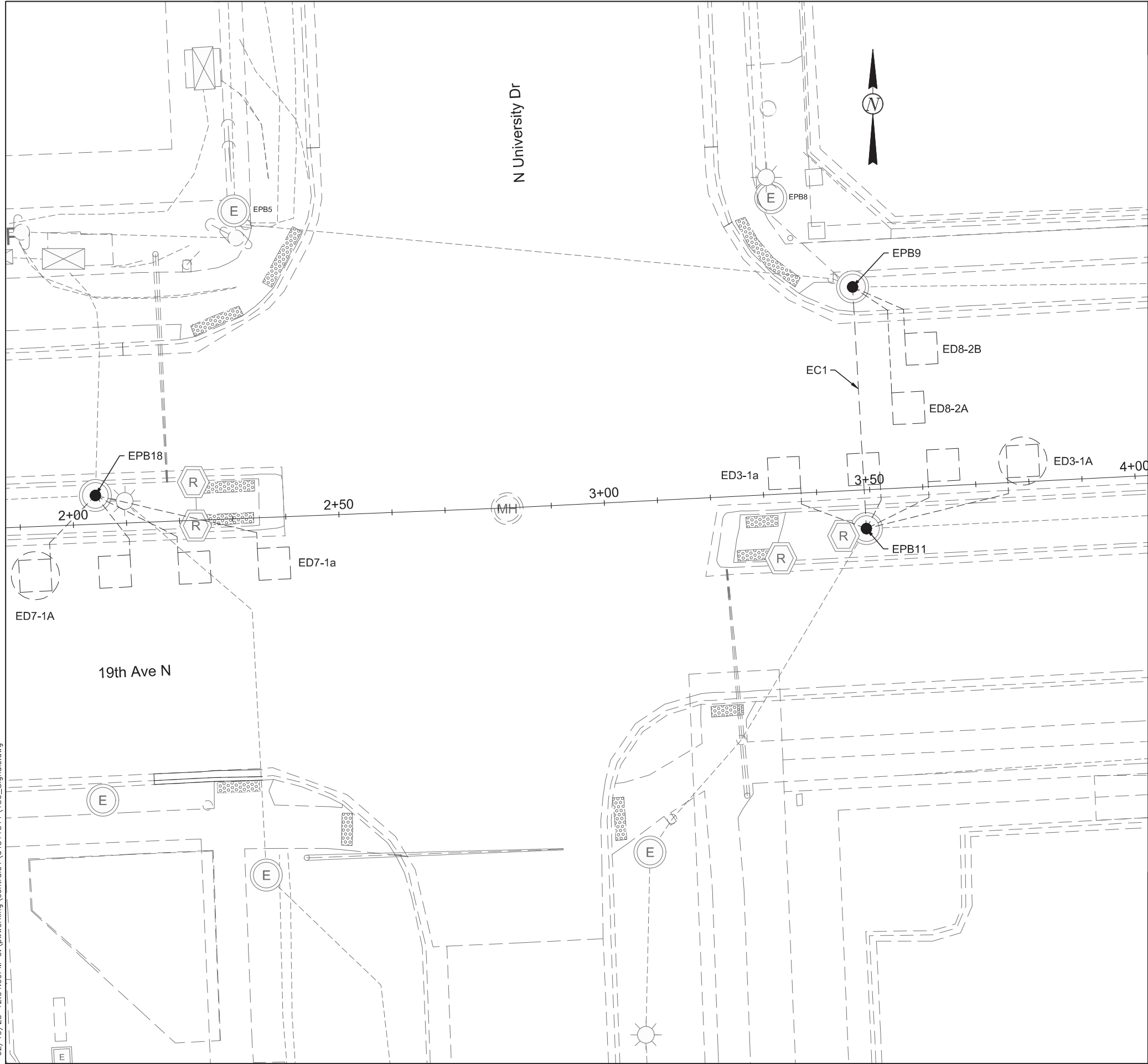

EPB9 - Existing Pull Box to Remain.

EC1 - Locate existing 2" conduit. Cut at Sta 3+48.92 - 7.5' Lt. Protect for field splice. Remove existing 2" conduit from cut to EPB11.

ED8 - 2B - Existing detector loop to remain.

ED8-2A - Existing detector loop to remain.

Pull back both ED3-1A & ED3-1a loop leads to EPB9 and terminate to new loops when sawed in.

Pull back both ED7-1A & ED7-1a loop leads to EPB18 and terminate to new loops when sawed in.

EPB11 - Remove and salvage back to the city.

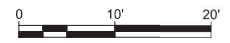

Fargo Intersection Safety
Existing Signal Layout

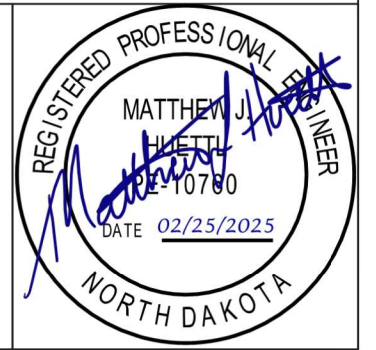

02/19/25 12:04:09PM C:\pwworking\central01\d43111311\150_Signals.dwg

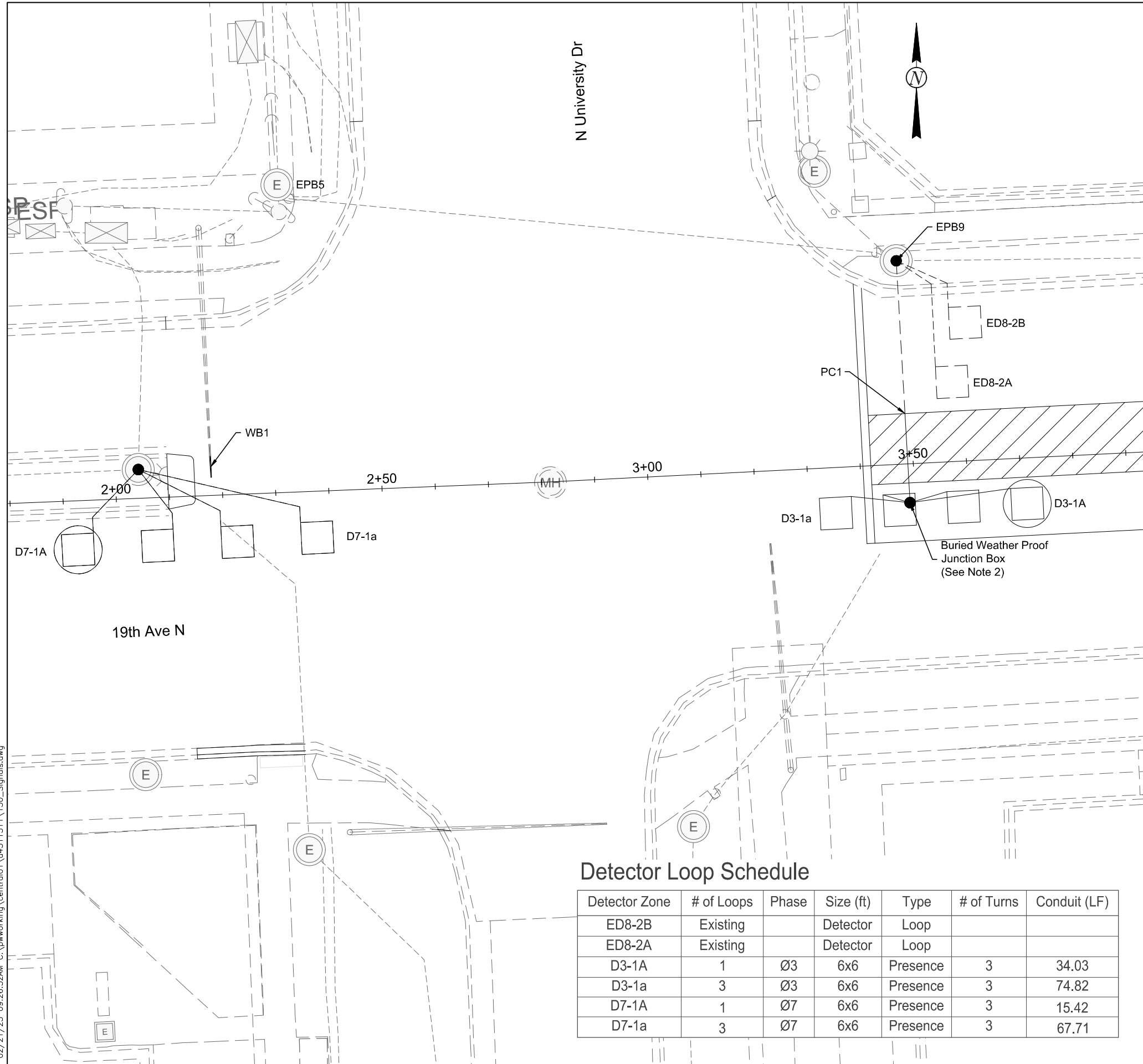

STATE	PROJECT NO.	SECTION NO.	SHEET NO.
ND	HEU-8-984(179)	150	2

WB1 - Install 5' mast arm extension.

PC1 - Field splice 14.80' - 2" conduit to existing 2" conduit. Install 4-6'x6' detector loops. (D3-1A, D3-1a)

D3-1a - Keep wires in the same conduit. Install 1" pipe in each panel for each loop that is cut.

D3-1A - Keep separate from D3-1a. Loop needs its own conduit. Install 1" pipe in each panel for each loop that is cut.

D7-1a - Replace existing signal detector loops

D7-1A - Replace existing signal detector loop.

Note 1: Existing 16 bay traffic signal cabinet, remove hot jumpers for channel 10 + 12, to enable RED arrow monitoring for OLB + OLD. F+I a Reno MMU2 with a fully jumpered card. F+I, 2 load switches and 2 flasher relays. Revise cabinet prints and perform a conflict text for added overlap channels.

Note 2: Add buried weather proof junction box to connect 4-1" loop conduits to the 2" existing conduit at PC1.

Quantities Incidental to "Traffic Signals System"	
	Quantity
Load Switches	2
Flasher Relays	2
MMU & Jumper Card	1
Traffic Signal Loop Detectors	8
Weather Proof Junction Box	1

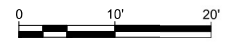

Detector Loop Schedule

Detector Zone	# of Loops	Phase	Size (ft)	Type	# of Turns	Conduit (LF)
ED8-2B	Existing		Detector	Loop		
ED8-2A	Existing		Detector	Loop		
D3-1A	1	Ø3	6x6	Presence	3	34.03
D3-1a	3	Ø3	6x6	Presence	3	74.82
D7-1A	1	Ø7	6x6	Presence	3	15.42
D7-1a	3	Ø7	6x6	Presence	3	67.71

Fargo Intersection Safety
Proposed Signal Layout

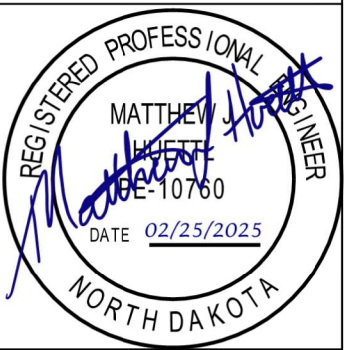

02/21/25 09:26:52AM C:\pwworking\central01\d4311311\150_Signals.dwg

All traffic signal equipment will be black in color.

All signal heads will be sig polycarbonate. All back plates will be louvered .063" thick aluminum.

Note 1: Remove and salvage 5 sec heads and signs back to the City.

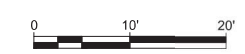

Fargo Intersection Safety
N University Dr & 19th Ave N
Traffic Signal Standards

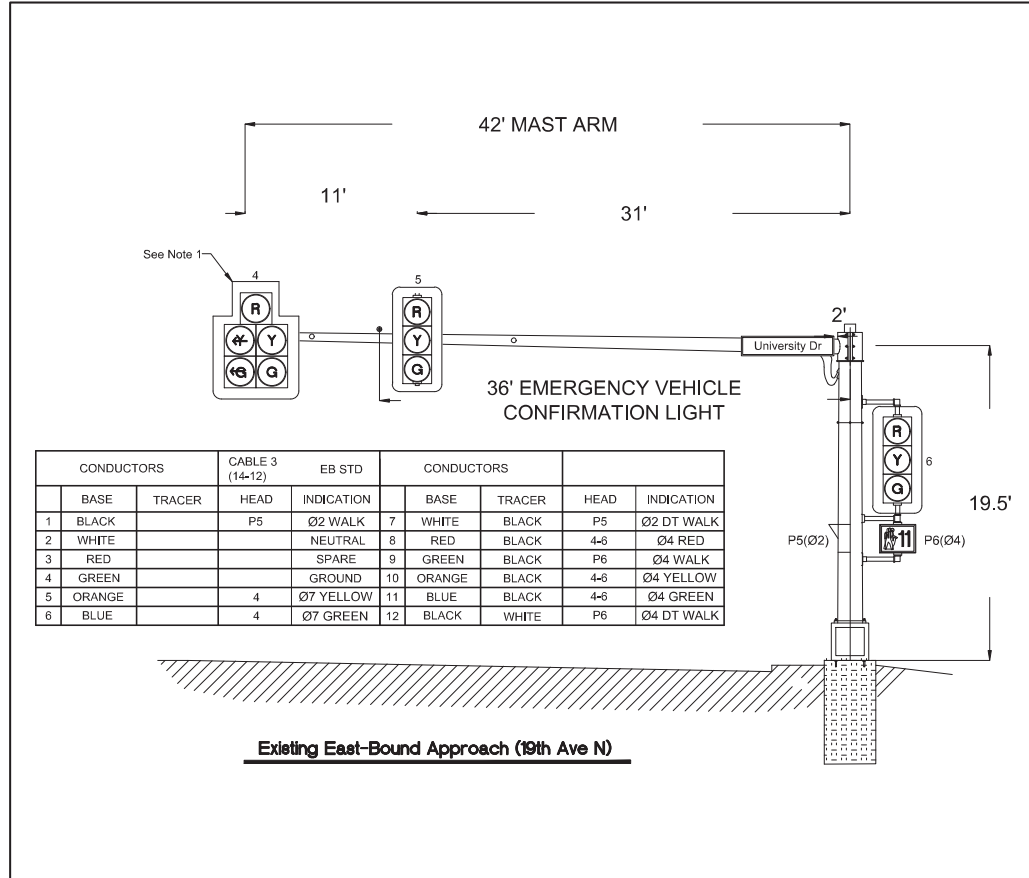
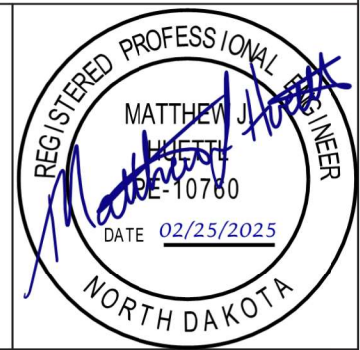

CONDUCTORS		CABLE 3 (14-12)		EB STD		CONDUCTORS			
BASE	TRACER	HEAD	INDICATION	BASE	TRACER	HEAD	INDICATION		
1	BLACK		Ø2 WALK	7	WHITE	BLACK	P5	Ø2 DT WALK	
2	WHITE		NEUTRAL	8	RED	BLACK	4-6	Ø4 RED	
3	RED		SPARE	9	GREEN	BLACK	P6	Ø4 WALK	
4	GREEN		GROUND	10	ORANGE	BLACK	4-6	Ø4 YELLOW	
5	ORANGE	4	Ø7 YELLOW	11	BLUE	BLACK	4-6	Ø4 GREEN	
6	BLUE	4	Ø7 GREEN	12	BLACK	WHITE	P6	Ø4 DT WALK	

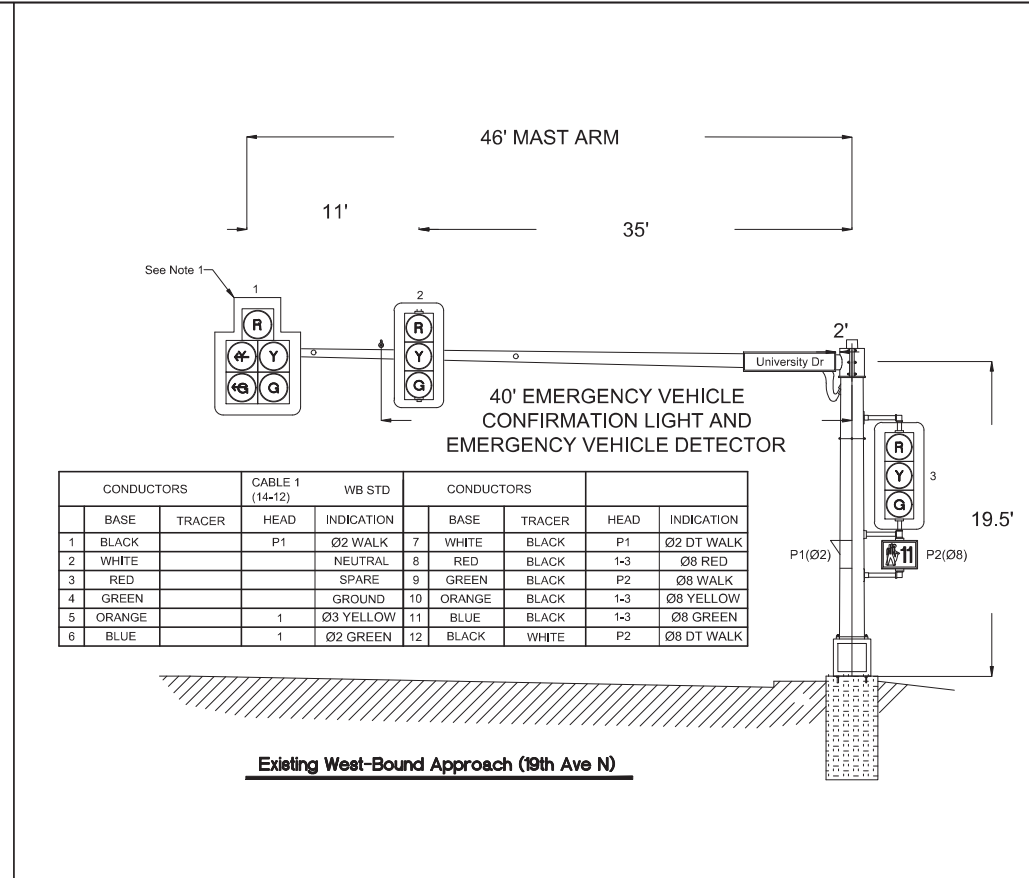

CONDUCTORS		CABLE 1 (14-12)		WB STD		CONDUCTORS			
BASE	TRACER	HEAD	INDICATION	BASE	TRACER	HEAD	INDICATION		
1	BLACK		Ø2 WALK	7	WHITE	BLACK	P1	Ø2 DT WALK	
2	WHITE		NEUTRAL	8	RED	BLACK	1-3	Ø8 RED	
3	RED		SPARE	9	GREEN	BLACK	P2	Ø8 WALK	
4	GREEN		GROUND	10	ORANGE	BLACK	1-3	Ø8 YELLOW	
5	ORANGE	1	Ø3 YELLOW	11	BLUE	BLACK	1-3	Ø8 GREEN	
6	BLUE	1	Ø2 GREEN	12	BLACK	WHITE	P2	Ø8 DT WALK	

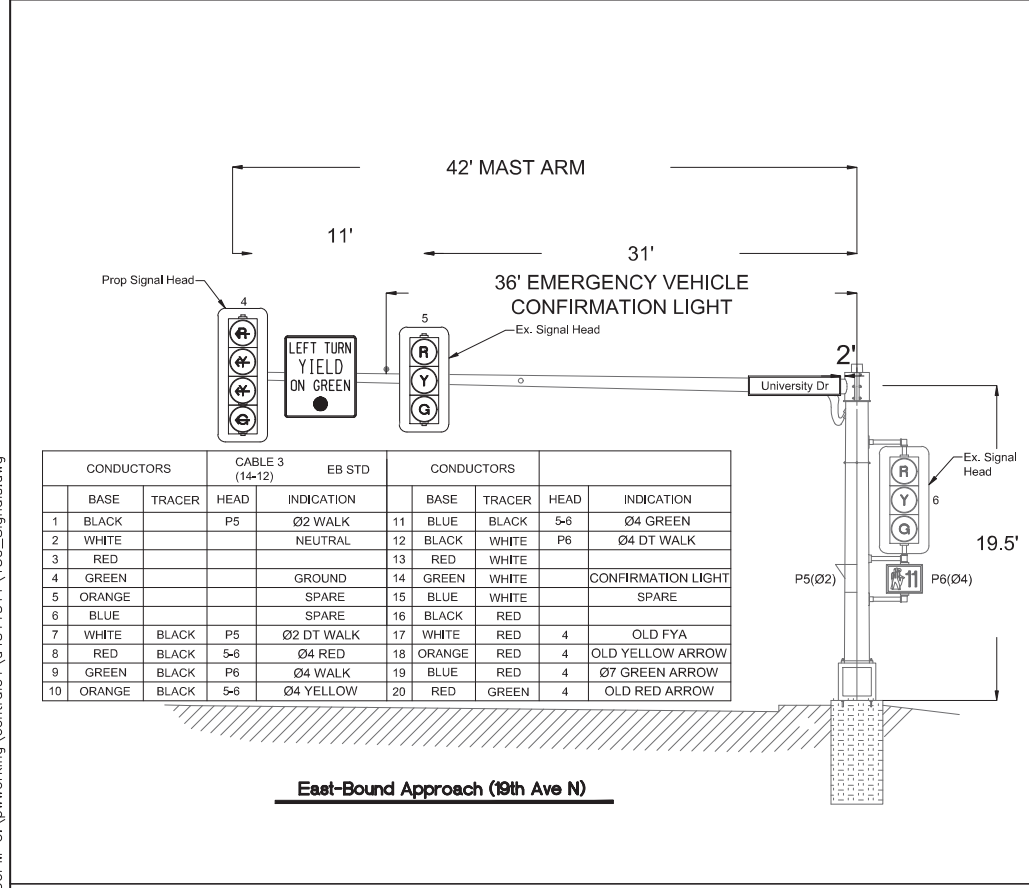

CONDUCTORS		CABLE 3 (14-12)		EB STD		CONDUCTORS			
BASE	TRACER	HEAD	INDICATION	BASE	TRACER	HEAD	INDICATION		
1	BLACK		Ø2 WALK	11	BLUE	BLACK	5-6	Ø4 GREEN	
2	WHITE		NEUTRAL	12	BLACK	WHITE	P6	Ø4 DT WALK	
3	RED		SPARE	13	RED	WHITE			
4	GREEN		GROUND	14	GREEN	WHITE		CONFIRMATION LIGHT	
5	ORANGE		SPARE	15	BLUE	WHITE		SPARE	
6	BLUE		SPARE	16	BLACK	RED			
7	WHITE	BLACK	P5	Ø2 DT WALK	17	WHITE	RED	4	OLD FYA
8	RED	BLACK	5-6	Ø4 RED	18	ORANGE	RED	4	OLD YELLOW ARROW
9	GREEN	BLACK	P6	Ø4 WALK	19	BLUE	RED	4	Ø7 GREEN ARROW
10	ORANGE	BLACK	5-6	Ø4 YELLOW	20	RED	GREEN	4	OLD RED ARROW

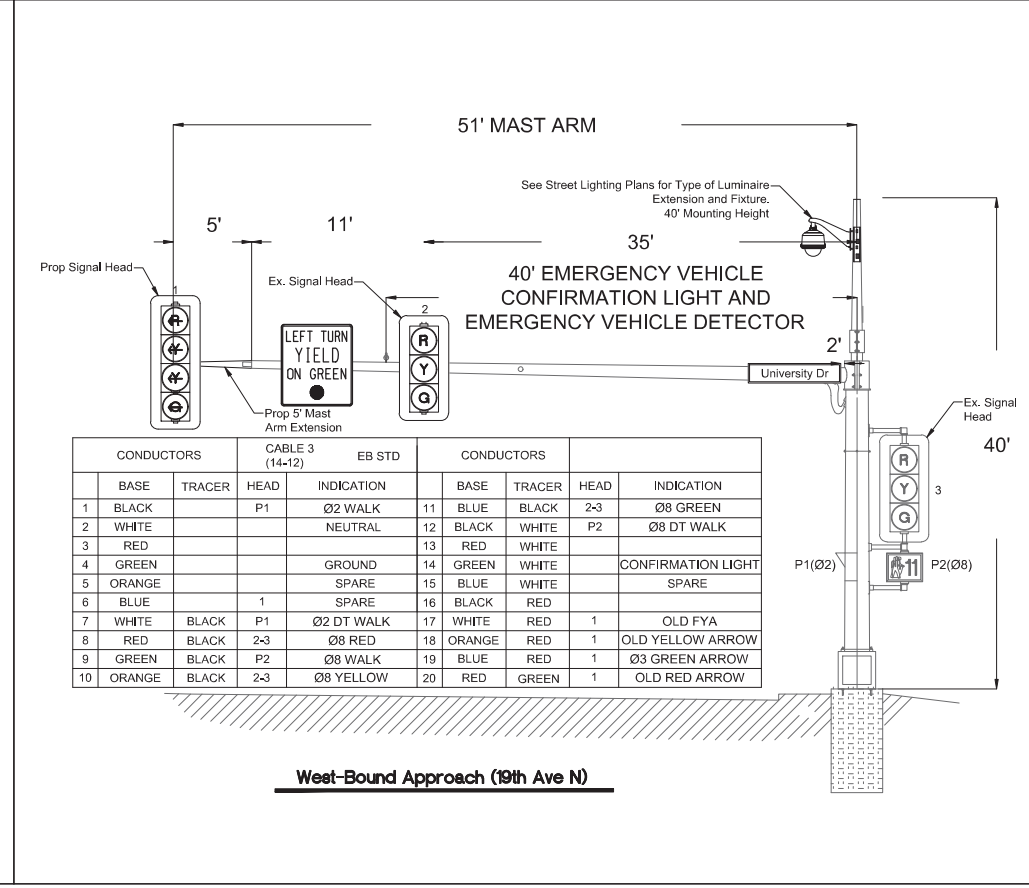

CONDUCTORS		CABLE 3 (14-12)		EB STD		CONDUCTORS			
BASE	TRACER	HEAD	INDICATION	BASE	TRACER	HEAD	INDICATION		
1	BLACK		Ø2 WALK	11	BLUE	BLACK	2-3	Ø8 GREEN	
2	WHITE		NEUTRAL	12	BLACK	WHITE	P2	Ø8 DT WALK	
3	RED		SPARE	13	RED	WHITE			
4	GREEN		GROUND	14	GREEN	WHITE		CONFIRMATION LIGHT	
5	ORANGE		SPARE	15	BLUE	WHITE		SPARE	
6	BLUE	1	SPARE	16	BLACK	RED			
7	WHITE	BLACK	P1	Ø2 DT WALK	17	WHITE	RED	1	OLD FYA
8	RED	BLACK	2-3	Ø8 RED	18	ORANGE	RED	1	OLD YELLOW ARROW
9	GREEN	BLACK	P2	Ø8 WALK	19	BLUE	RED	1	Ø3 GREEN ARROW
10	ORANGE	BLACK	2-3	Ø8 YELLOW	20	RED	GREEN	1	OLD RED ARROW

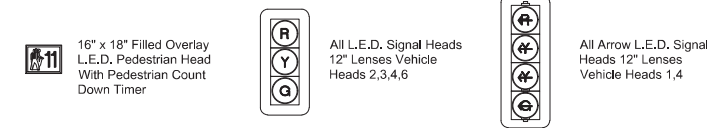

02/19/25 12:04:56PM C:\pwworking\central01\d4311311\150_Signals.dwg