

NDDOT ABBREVIATIONS

D-101-1

? This is a special text character used in the labeling of existing features. It indicates a feature that has an unknown characteristic, potentially based on: lack of description, location accuracy or purpose.

Abn abandoned
 Abut abutment
 Adj adjusted
 Aggr aggregate
 Ahd ahead
 ARV air release valve
 Align alignment
 Al alley
 Alt alternate
 Alum aluminum
 ADA Americans with Disabilities Act
 & and
 Appr approach
 Approx approximate
 ACP asbestos cement pipe
 Asph asphalt
 AC asphalt cement
 Assmd assumed
 @ at
 Atten attenuation
 ATR automatic traffic recorder
 Ave Avenue
 Avg average
 ADT average daily traffic

Bk back
 BF back face
 Balc balcony
 B Wire barbed wire
 Barr barricade
 Btry battery
 BI beehive inlet
 Beg begin
 BG below grade
 BM bench mark
 Bkwy bikeway
 Bit bituminous
 Blk block
 BH bore hole
 Bot bottom
 Blvd Boulevard
 Bndry boundary
 Brkwy breakaway
 Br bridge
 Bldg building
 Bus. business
 BV butterfly valve
 Byp bypass

C Gdrl cable guardrail
 Calc calculate
 CIP cast iron pipe
 CB catch basin
 CRS cationic rapid setting
 C Gd cattle guard
 C To C center to center
 CL or C centerline
 Ch chain
 Chnlk chain-link
 Ch Blk channel block
 Ch Ch channel change
 Chk check
 Chsld chiseled
 Cir circle
 Cl class
 Clnt clean-out
 Clr clear
 Cl&gr clearing & grubbing
 Comb. combination
 Coml commercial
 Compr compression
 CADD computer aided drafting & design
 Conc concrete
 CECB concrete erosion control blanket
 Cond conductor
 Const construction
 Cont continuous
 CSB continuous split barrel sample
 Contr contraction
 Contr contractor
 CP control point
 Coord coordinate
 Cor corner
 Corr corrected
 CAES corrugated aluminum end section
 CAP corrugated aluminum pipe
 CMES corrugated metal end section
 CMP corrugated metal pipe
 CPVCP corrugated poly-vinyl chloride pipe
 CSES corrugated steel end section
 CSFES corrugated steel flared end section
 CSP corrugated steel pipe
 CSTES corrugated steel traversable end section
 Co County
 Crse course
 Ct Court
 Xarm cross arm
 Xbuck cross buck
 Xsec cross sections
 Xing crossing
 Xrd crossroad
 Crn crown

Culv culvert
 C&G curb & gutter
 CI curb inlet
 CR curb ramp
 C cut
 Dd Ld dead load
 Defl deflection
 Defm deformed
 DInt delineate
 DIntr delineator
 Depr depression
 Desc description
 Det detail
 DWP detectable warning panel
 Dtr detour
 Dia or \emptyset diameter
 Dir direction
 Dist distance
 DM disturbed material
 DB ditch block
 DG ditch grade
 Dbl double
 Dn down
 Dwg drawing
 Dr drive
 Drwy driveway
 DI drop inlet
 D dry density

Ea each
 Esmt easement
 E East
 EB Eastbound
 Elast elastomeric
 EL electric locker
 E Mtr electric meter
 Elec electric/al
 EDM electronic distance meter
 Elev or El elevation
 Ellipt elliptical
 Emb embankment
 Emuls emulsion/emulsified
 ES end section
 Engr engineer
 ESS environmental sensor station
 Eq equal
 Evgr evergreen
 Exc excavation
 Exst existing
 Exp expansion
 Expy Expressway
 E external of curve
 Extru extruded

FOS factor of safety
 Fed Federal
 FP feed point
 Fn fence
 Fn P fence post
 FO fiber optic
 FD field drive
 F fill
 FAA fine aggregate angularity
 FH fire hydrant
 Fl flange
 Flrd flared
 FES flared end section
 F Bcn flashing beacon
 FA flight auger sample
 FL flow line
 Ftg footing
 FM force main
 Fnd found
 Fdn foundation
 Frac fractional
 Frwy freeway
 Frt front
 FF front face
 F Disp fuel dispenser
 FFP fuel filler pipes
 FLS fuel leak sensor
 Furn furnish/ed

NORTH DAKOTA DEPARTMENT OF TRANSPORTATION	
07-01-14	
REVISIONS	
DATE	CHANGE
04-23-18	General Revisions
05-20-18	General Revisions
12-10-20	General Revisions
08-16-22	General Revisions



NDDOT ABBREVIATIONS

Galv	galvanized	Ln	lane	Obsc	obscure(d)	Qty	quantity
Gar	garage	Lg	large	Ocpd	occupied	Qtr	quarter
Gs L	gas line	Lat	latitude	Ocpy	occupy		
G Reg	gas line regulator	Lt	left	O/s	offset		
GMV	gas main valve	Lens	lenses	OC	on center	Rad or R	radius
G Mtr	gas meter	Lvl	level	C	one dimensional consolidation	RR	railroad
GSV	gas service valve	Lvng	leveling	OC	organic content	Rlwy	railway
GVP	gas vent pipe	Lht	light	Orig	original	Rsd	raised
GV	gate valve	LP	light pole	O To O	out to out	RC	rapid curing
Ga	gauge	Ltg	lighting	OD	outside diameter	Rec	record
Gov	government	Liq	liquid	OH	overhead	Recy	recycle
Grd	graded/grade	LL	liquid limit			RAP	recycled asphalt pavement
Grnd	ground	Loc	location			RPCC	recycled portland cement concrete
GWM	ground water monitor	Long.	longitude	PMT	pad mounted transformer	Ref	reference
Gdrl	guardrail	Lp	loop	Pg	pages	R Mkr	reference marker
Gtr	gutter	LD	loop detector	Pntd	painted	RM	reference monument
		Lum	luminaire	Pr	pair	RP	reference point
				Pnl	panel	Refl	reflectorized
H Plg	H piling			Pk	park	RCB	reinforced concrete box
Hdwl	headwall	Mb	mailbox	PSD	passing sight distance	RCES	reinforced concrete end section
Ht	height	ML	main line	Pvmt	pavement	RCFES	reinforced concrete flared end section
Hel	helical	MH	manhole	Ped	pedestal	RCP	reinforced concrete pipe
HDPE	high density polyethylene	Mkd	marked	Ped	pedestrian	RCPS	reinforced concrete pipe sewer
HM	high mast	Mkr	marker	PPP	pedestrian pushbutton post	RCTES	reinforced concrete traversable end section
HP	high pressure	Mkg	marking	Pen.	penetration	Reinf	reinforcement
HPS	high pressure sodium	MA	mast arm	Perf	perforated	Res	reservation
HTCG	high tension cable guardrail	Matl	material	Per.	perimeter	Res	residence
Hwy	highway	Max	maximum	Perm	permanent	Ret	retaining
Hor	horizontal	MC	meander corner	PL	pipeline	Rev	reverse
HBP	hot bituminous pavement	Meas	measure	PI	place	Rt	right
HMA	hot mix asphalt	Mdn	median	P&P	plan & profile	R/W	right of way
Hyd	hydrant	MD	median drain	PL	plastic limit	Riv	river
Ph	hydrogen ion content	MC	medium curing	Pl or \bar{P}	plate	Rd	road
		MGS	Midwest Guardrail System	Pt	point	Rdbd	road bed
		MM	mile marker	PE	polyethylene	Rdwy	roadway
Id	identification	MP	mile post	PVC	polyvinyl chloride	RWIS	roadway weather information system
Incl	inclinometer tube	Min	minimum	PCC	Portland Cement concrete	Rk	rock
IMH	inlet manhole	Misc	miscellaneous	PP	power pole	Rt	route
ID	inside diameter	Mon	monument	Preempt	preemption		
Inst	instrument	Mnd	mound	Prefab	prefabricated		
Intchg	interchange	Mtbl	mountable	Prfmd or Pref	performed		
Intmdt	intermediate	Mtd	mounted	Prep	preparation		
Intscn	intersection	Mtg	mounting	Press.	pressure		
Inv	invert	Mk	muck	PRV	pressure relief valve		
IP	iron pipe			Prestr	prestressed		
				Pvt	private		
				PD	private drive		
Jt	joint	Neop	neoprene	Prod.	production/produce		
Jct	junction	Ntwk	network	Prog	programmed		
		N	North	Prop.	property		
		NE	North East	Prop Ln	property line		
		NW	North West	Ppsd	proposed		
		NB	Northbound	PB	pull box		
		No. or #	number				

NORTH DAKOTA DEPARTMENT OF TRANSPORTATION	
07-01-14	
REVISIONS	
DATE	CHANGE
08-03-15	General Revisions
04-23-18	General Revisions
12-18-20	General Revisions
08-16-22	General Revisions

KIRK J. HOFF
REGISTERED
PROFESSIONAL
PE-4683
ENGINEER
NORTH DAKOTA
08/16/22

NDDOT ABBREVIATIONS

D-101-3

Salv	salvage(d)	Tel	telephone
San	sanitary sewer line	Tel B	Telephone Booth
Sec	section	Tel P	telephone pole
SL	section line	Tv	television
Sep	separation	Temp	temperature
Seq	sequence	Temp	temporary
Serv	service	TBM	temporary bench mark
Sht	sheet	T	thinwall tube sample
Shtng	sheeting	Ts	topsoil
Shldr	shoulder	Traf	traffic
Sw or Sdwk	sidewalk	TSCB	traffic signal control box
SD	sight distance	Tr	trail
SN	sign number	Transf	transformer
Sig	signal	Trans	transition
Sgl	single	TT	transmission tower
SRCP	slotted reinforced concrete pipe	TES	traversable end section
SC	slow curing	Trans	transverse
SS	slow setting	Trtd	treated
Sm	small	Trmt	treatment
S	South	Qc	triaxial compression
SE	South East	TERO	tribal employment rights ordinance
SW	South West	Tpl	triple
SB	Southbound	Typ	typical
Sp	spaces		
Spcl	special	Qu	unconfined compressive strength
SA	special assembly	Ugrnd	underground
SP	special provisions	Util	utility
G	specific gravity		
Spk	spike	VG	valley gutter
SB	split barrel sample	Vap	vapor
SH	sprinkler head	Vert	vertical
SV	sprinkler valve	VCP	vitrified clay pipe
Sq	square	Vol	volume
Stk	stake	VSFS	vehicle speed feedback sign
Std	standard		
N	standard penetration test	Wkwy	walkway
Std Specs	standard specifications	W	water content
Stm L	steam line	WGV	water gate valve
SEC	steel encased concrete	WL	water line
SMA	stone matrix asphalt	WM	water main
SSD	stopping sight distance	WMV	water main valve
SD	storm drain	W Mtr	water meter
St	street	WSV	water service valve
SPP	structural plate pipe	WW	water well
SPPA	structural plate pipe arch	Wrng	wearing
Str	structure	WIM	weigh in motion
Subd	subdivision	W	west
Sub	subgrade	WB	westbound
Sub Prep	subgrade preparation	Wrng	wiring
Ss	subsoil	W/	with
SS	supplement specification	W/o	without
Supp	supplemental	WC	witness corner
Surf	surfacing		
Surv	survey		
Sym	symmetrical		

NORTH DAKOTA DEPARTMENT OF TRANSPORTATION	
07-01-14	
REVISIONS	
DATE	CHANGE
08-03-15	General Revisions
04-23-18	General Revisions
12-18-20	General Revisions
08-16-22	General Revisions



NDDOT ABBREVIATIONS

D-101-4

MEASUREMENTS

ac acres
 A ampere
 Bd Ft board feet
 Cd candela
 cm centimeter
 C coulomb
 CF cubic feet
 m3 cubic meter
 m3/s cubic meters per second
 CY cubic yard
 CY/mi cubic yards per mile
 D or Deg degree
 F Fahrenheit
 F farad
 ft feet/foot
 Gal gallon
 G giga
 Ha hectare
 H henry
 Hz hertz
 hr hour(s)
 in inch
 J joule
 K kelvin
 kN kilo newton
 kPa kilo pascal
 kg kilogram
 kg/m3 kilogram per cubic meter
 km kilometer
 K Kip(s)
 LF linear foot
 L litre
 Lm lumen
 L sum lump sum
 Lx lux
 M Hr man hour
 M mega
 m meter
 m/s meters per second
 mi mile
 mL milliliter
 mm millimeter
 mm/hr millimeters per hour
 n nano
 N newton
 Pa pascal
 lb pounds
 sec seconds
 S siemens
 SF square feet
 km2 square kilometer
 m2 square meter
 SY square yard
 Sta Yd station yards
 SI Systems International

T tesla
 T/mi tons per mile
 V volt
 W watt
 Wb weber

SURVEY DESCRIPTIONS

Az azimuth
 Bs backsight
 Brg bearing
 BP Cap blue plastic cap
 BS both sides
 BC brass cap
 CS curve to spiral
 Eq equation
 E external of curve
 FS far side
 FB field book
 Fs foresight
 Geod geodetic
 GIS Geographical Information System
 GPS Global Positioning System
 HI height of instrument
 IM iron monument
 I Pn iron pin
 LS Land Surveyor (licensed)
 LSIT Land Surveyor In Training
 L length of curve
 LC long chord
 LB level book
 Mer meridian
 M mid ordinate of curve
 NGS National Geodetic Survey
 NS near side
 Obsn observation
 Off Loc office location
 OP Cap orange plastic cap
 PK Parker-Kalon nail
 P Cap plastic cap
 PP Cap pink plastic cap
 PCC point of compound curve
 PC point of curve
 PI point of intersection
 PRC point of reverse curvature
 PT point of tangent
 POC point on curve
 POT point on tangent
 RTP random traverse point
 Rge range
 RP Cap red plastic cap
 SC spiral to curve
 ST spiral to tangent
 Sta station
 SE superelevation
 Tan tangent
 T tangent (semi)
 TS tangent to spiral
 Twp township
 TB transit book
 TP traverse point
 TP turning point
 USC&G US Coast & Geodetic Survey
 USGS US Geologic Survey
 VC vertical curve
 WGS World Geodetic System
 YP Cap yellow plastic cap
 Z zenith

SOIL TYPES

Cl clay
 Cl F clay fill
 Cl Hvy clay heavy
 Cl Lm clay loam
 Co S coal slack
 C Gr coarse gravel
 CS coarse sand
 FS fine sand
 Gr gravel
 Lig Co lignite coal
 Lig Sl lignite slack
 Lm loam
 Rk rock
 Sd sand
 Sdy Cl sandy clay
 Sdy Cl Lm sandy clay loam
 Sdy Fl sandy fill
 Sdy Lm sandy loam
 Sc scoria
 Sh shale
 Si Cl silt clay
 Si Cl Lm silty clay loam
 Si Lm silty loam

NORTH DAKOTA DEPARTMENT OF TRANSPORTATION	
07-01-14	
REVISIONS	
DATE	CHANGE
12-18-20	Sheet Added - Continued from D-101-3



NDDOT UTILITY COMPANY AND ORGANIZATION ABBREVIATIONS

D-101-10

702COM 702 Communications
 ACCENT Accent Communications
 AGASSIZ WU Agassiz Water Users Incorporated
 AGC Associated General Contractors of America
 ALL PL Alliance Pipeline
 ALL SEAS WU All Seasons Water Users Association
 AMOCO PI Amoco Pipeline Company
 AMRDA HESS Amerada Hess Corporation
 AT&T AT&T Corporation
 B PAW Bear Paw Energy Incorporated
 BAKER ELEC Baker Electric
 BASIN ELEC Basin Electric Cooperative Incorporated
 BEK TEL Bek Communications Cooperative
 BELLE PL Belle Fourche Pipeline Company
 BLM Bureau of Land Management
 BNSF Burlington Northern Santa Fe Railway
 BOEING Boeing
 BRNS RWD Barnes Rural Water District
 BURK-DIV ELEC Burke-Divide Electric Cooperative
 BURL WU Burleigh Water Users
 CABLE ONE Cable One
 CABLE SERV Cable Services
 CAP ELEC Capital Electric Cooperative Incorporat
 CASS CO ELEC Cass County Electric Cooperative
 CASS RWU Cass Rural Water Users Incorporated
 CAV ELEC Cavalier Rural Electric Cooperative
 CBLCOM Cablecom Of Fargo
 CENEX PL Cenex Pipeline
 CENT PL WATER DIST Central Pipe Line Water District
 CENT PWR ELEC Central Power Electric Cooperative
 CENTURYLINK CenturyLink
 COE Corps of Engineers
 CONS TEL Consolidated Telephone
 CONT RES Continental Resource Inc
 CPR Canadian Pacific Railway
 D O E Department Of Energy
 DAK CARR Dakota Carrier Network
 DAK CENT TEL Dakota Central Telephone
 DAK RWD Dakota Rural Water District
 DGC Dakota Gasification Company
 DICKEY R NET Dickey Rural Networks
 DICKEY RWU Dickey Rural Water Users Association
 DICKEY TEL Dickey Telephone
 DNRR Dakota Northern Railroad
 DOME PL Dome Pipeline Company
 DVELEC Dakota Valley Electric Cooperative
 DVMW Dakota, Missouri Valley & Western
 ENBRDG Enbridge Pipelines Incorporated
 ENVENTIS Enventis Telephone
 EQUINOR Equinor Pipeline
 FALK MNG Falkirk Mining Company
 FHWA Federal Highway Administration
 G FKS-TRL WD Grand Forks-traill Water District
 GETTY TRD & TRAN Getty Trading & Transportation
 GLDN W ELEC Golden West Electric Cooperative
 GRGS CO TEL Griggs County Telephone
 GTR RAMSEY WD Greater Ramsey Water District

GT PLNS NAT GAS Great Plains Natural Gas Company
 HALS TEL Halstad Telephone Company
 IDEA1 Idea1
 INT-COMM TEL Inter-Community Telephone Company
 KANEB PL Kaneb Pipeline Company
 KEM ELEC Kem Electric Cooperative Incorporated
 KOCH GATH SYS Koch Gathering Systems Incorporated
 LKHD PL Lakehead Pipeline Company
 LNGDN RWU Langdon Rural Water Users Incorporated
 LWR YELL R ELEC Lower Yellowstone Rural Electric
 MCKNZ CON McKenzie Consolidated Telcom
 MCKENZ ELEC McKenzie Electric Cooperative
 MCKNZ WRD McKenzie County Water Resource District
 MCLEOD McLeod USA
 MCLN ELEC McLean Electric Cooperative
 MCLN-SHRDN R WAT McLean-Sheridan Rural Water
 MDU Montana-dakota Utilities
 MIDCO MidContinent Communications
 MIDSTATE TEL Midstate Telephone Company
 MINOT CABLE Minot Cable Television
 MINOT TEL Minot Telephone Company
 MISS VALL COMM Missouri Valley Communications
 MISS W W S Missouri West Water System
 MNKOTA PWR Minnkota Power
 MOR-GRAN-SOU ELEC Mor-gran-sou Electric Cooperative
 MOUNT-WILLI ELEC Mountrail-williams Electric Cooperative
 MRE LBTY TEL Moore & Liberty Telephone
 MUNICIPAL City Water And Sewer
 MUNICIPAL City Of '.....'
 N CENT ELEC North Central Electric Cooperative
 N VALL W DIST North Valley Water District
 ND PKS & REC North Dakota Parks And Recreation
 ND TEL North Dakota Telephone Company
 NDDOT North Dakota Department of Transportation
 NDSU SOIL SCI DEPT NDSU Soil Science Department
 NEMONT TEL Nemont Telephone
 NODAK R ELEC Nodak Rural Electric Cooperative
 NOON FRMS TEL Noonan Farmers Telephone Company
 NPR Northern Plains Railroad
 NSP Northern States Power
 NTH PRAIR RW Northern Prairie Rural Water Association
 NTHN BRDR PL Northern Border Pipeline
 NTHN PLNS ELEC Northern Plains Electric Cooperative Incorporated
 NTHWSTRN REF Northwestern Refinery Company
 NW COMM Northwest Communication Cooperation
 NWRWD Northwest Rural Water District
 ONEOK Oneok gas
 OSHA Occupational Safety and Health Administration
 OTTR TL PWR Otter Tail Power Company
 PAAP Plains All American Pipeline
 P L E M Prairielands Energy Marketing
 POLAR COM Polar Communications
 PVT ELEC Private Electric
 QWEST Qwest Communications
 R&T W SUPPLY R & T Water Supply Association

RED RIV COMM Red River Rural Communications
 RESVTN TEL Reservation Telephone
 ROBRTS TEL Roberts Company Telephone
 R-RIDER ELEC Roughrider Electric Cooperative
 RRVW Red River Valley & Western Railroad
 S CENT REG WD South Central Regional Water District
 S E W U South East Water Users Incorporated
 SCOTT CABLE Scott Cable Television Dickinson
 SHERDN ELEC Sheridan Electric Cooperative
 SHEYN VLY ELEC Sheyenne Valley Electric Cooperative
 SKYTECH Skyland Technologies Incorporated
 SLOPE ELEC Slope Electric Cooperative Incorporated
 SOURIS RIV TELCOM Souris River Telecommunications
 ST WAT COMM State Water Commission
 STATE LN WATER State Line Water Cooperative
 STER ENG Sterling Energy
 STUT RWU Stutsman Rural Water Users
 SW PL PRJ Southwest Pipeline Project
 T M C Turtle Mountain Communications
 TCI TCI of North Dakota
 TESORO GHG PLNS PL Tesoro High Plains Pipeline
 TRI-CNTY WU Tri-County Water Users Incorporated
 TRL CO RWU Traill County Rural Water Users
 UNTD TEL United Telephone
 UPPR SOUR WUA Upper Souris Water Users Association
 US SPRINT U.S. Sprint
 USAF MSL CABLE U.S.A.F. Missile Cable
 USFWS US Fish and Wildlife Service
 USW COMM U.S. West Communications
 VRNDRY ELEC Verendrye Electric Cooperative
 W RIV TEL West River Telephone Incorporated
 WAPA Western Area Power Administration
 WAWSA Western Area Water Supply Authority
 WEB W. E. B. Water Development Association
 WILLI RWA Williams Rural Water Association
 WILSTN BAS PL Williston Basin Interstate Pipeline Company
 WLSH RWD Walsh Water Rural Water District
 WOLVRTN TEL Wolverton Telephone
 XLENER Xcel Energy
 YSVR Yellowstone Valley Railroad

NORTH DAKOTA DEPARTMENT OF TRANSPORTATION	
07-01-14	
REVISIONS	
DATE	CHANGE
04-23-18	General Revisions
05-20-18	General Revisions
12-18-20	General Revisions
08-16-22	General Revisions



LINE STYLES

D-101-20

Existing Topography

- Void - Void - Void - V Existing Ground Void
- Existing Cemetary Boundary
- Existing Box Culvert Bridge
- Existing Concrete Surface
- Existing Drainage Structure
- Existing Gravel Surface
- Existing Riprap
- Existing Dirt Surface
- Existing Asphalt Surface
- Existing Tie Point Line
- Existing Railroad Centerline
- Existing Guardrail Cable
- Existing Guardrail Metal
- Existing Edge of Water
- Existing Fence
- Existing Railroad
- Existing Field Line
- Exst Flow
- Existing Curb
- Existing Valley Gutter
- Existing Driveway Gutter
- Existing Curb and Gutter
- Existing Mountable Curb and Gutter

- Existing 3-Cable w Posts
- Site Boundary
- Existing Berm, Dike, Pit, or Earth Dam
- Existing Ditch Block
- Existing Tree Boundary
- Existing Brush or Shrub Boundary
- Existing Retaining Wall
- Existing Planter or Wall
- Existing W-Beam Guardrail with Posts
- Existing Railroad Switch
- Gravel Pit - Borrow Area
- Existing Wet Area-Vegetation Break
- Existing High Tension Cable Guardrail
- Existing High Tension Cable Guardrail with Posts

Proposed Topography

- 3-Cable w Posts
- Flow
- Fence
- Remove Line
- Wall
- Retaining Wall (Plan View)
- W-Beam w Posts
- High Tension Cable Guardrail with Posts

Existing Utilities

- Existing Electrical
- Existing Fiber Optic Line
- Existing TV Fiber Optic
- Existing Gas Pipe
- Existing Overhead Utility Line
- Existing Power
- Existing Fuel Pipeline
- Existing Undefined Above Ground Pipe Line
- Existing Sanitary Sewer
- Existing Sanitary Force Main
- Existing Storm Drain
- Existing Storm Drain Force Main
- Existing Culvert
- Existing Telephone Line
- Existing TV Line
- Existing Water or Steam Line
- Existing Under Drain
- Existing Slotted Drain
- Existing Conduit
- Existing Conductor
- Existing Down Guy Wire Down Guy
- Existing Underground Vault or Lift Station

Proposed Utilities

- 24 Inch Pipe
- Reinforced Concrete Pipe
- Under Drain
- Edge Drain

Traffic Utilities

- Conductor
- Fiber Optic
- Existing Loop Detector
- Existing Double Micro Loop Detector
- Micro Loop Detector Double
- Existing Micro Loop Detector
- Micro Loop Detector
- Signal Head with Mast Arm
- Existing Signal Head with Mast Arm

Sign Structures

- Existing Overhead Sign Structure
- Existing Overhead Sign Structure Cantilever
- Overhead Sign Structure Cantilever

NORTH DAKOTA DEPARTMENT OF TRANSPORTATION	
07-01-14 REVISIONS	
DATE	CHANGE
09-23-16	Added and Revised Items, Organized by Functional Groups General Revisions
12-18-20	

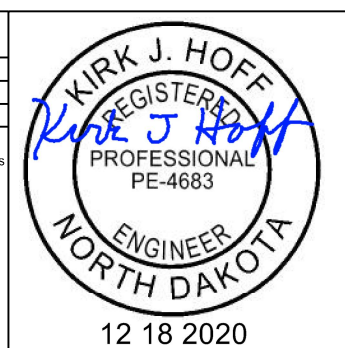

LINE STYLES

D-101-21

Right Of Way

- Easement
- Existing Easement
- Right of Way
- Existing Right of Way
- Existing Right of Way Railroad
- Existing Right of Way Not State Owned
- Existing Government Lot Line
- Existing Adjacent Block Lines
- Existing Adjacent Lot Lines
- Existing Adjacent Property Line
- Existing Adjacent Subdivision Lines
- Sight Distance Triangle Line
- Dimension Leader

Boundary Control

- ////// Existing City Corporate Limits or Reservation Boundary
- Existing State or International Line
- Existing Township
- Existing County
- Existing Section Line
- Existing Quarter Section Line
- Existing Sixteenth Section Line
- Existing Centerline
- Tangent Line

Cross Sections and Typical

- Existing Ground
- Existing Topsoil (Cross Section View)
- void - void - void - v Existing Ground Void (Not Surveyed)
- Existing Concrete
- Existing Aggregate (Cross Section View)
- Existing Curb and Gutter (Cross Section View)
- Existing Asphalt (Cross Section View)
- Existing Reinforcement Rebar

Geotechnical

- D ----- D ----- Geotextile Fabric Type D
- **Geo** ----- **Geo** ----- Geogrid
- R ----- R ----- Geotextile Fabric Type R
- R ----- R ----- Geotextile Fabric Type R1
- RR ----- RR ----- Geotextile Fabric Type RR
- S ----- S ----- Geotextile Fabric Type S

Countours

- Depression Contours
- Supplemental Contour

Profile

- Subgrade, Subcut or Ditch Grade
- Topsoil Profile

Striping

- Centerline Pavement Marking
- ===== Barrier with Centerline Pavement Marking
- ===== Barrier Pavement Marking
- - - - - Stripe 4 IN Dotted Extension White
- - - - - Stripe 8 IN Dotted Extension White
- - - - - Stripe 8 IN Lane Drop

Pavement Joints

- ===== Doweled Joint
- +++++ Tie Bar 30 Inch 4 Foot Center to Center
- +++++ Tie Bar 18 Inch 3 Foot Center to Center
- +++++ Tie Bar at Random Spacing

Bridge Details

- Small Hidden Object
- Large Hidden Object
- Phantom Object
- Existing Conditions Object
- Centerline Main
- Centerline Secondary
- Excavation Limits
- Proposed Ground
- Sheet Piling

Erosion Control

- Limits of Const Transition Line
- Bale Check
- Rock Check
- s ----- s ----- Floating Silt Curtain
- SF ----- SF ----- Silt Fence
- Excavation Limits
- Fiber Rolls

Environmental

- Wetland Mitigation
- Existing Wetland Easement USFWS
- Existing Wetland Jurisdictional
- Existing Wetland
- Tree Row

NORTH DAKOTA DEPARTMENT OF TRANSPORTATION	
07-01-14	
REVISIONS	
DATE	CHANGE
09-23-16	Added and Revised Items, Organized by Functional Groups General Revisions
12-18-20	



SYMBOLS



North Arrow (Half Scale)



Alignment Data Point



Alignment Monument



Spot Elevation



Existing Miscellaneous Spot



Existing Access Control Arrow



Existing Benchmark



Reset USGS Marker



Iron Monument Found



Iron Pin R/W Monument



Property Corner



Iron Pin Reference Monument



Right of Way Marker (Exst, Ppsd, Reset)



Existing Federal Reference Corner



Existing Section Corner (Full, Quarter, Sixteenth, Meander)



Existing Witness Corner



Existing Control Point (CP, GPS-RTK, TRI)



Existing Traverse PI Aerial Panel



Existing Reference Marker Point NGS



Existing EFB Misc



Existing Bush or Shrub



Existing Large Evergreen Tree



Existing Small Evergreen Tree



Existing Large Tree



Existing Small Tree



Existing Tree Trunk

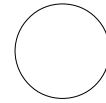

Cairn or Stone Circle



Existing Artifact



Existing Satellite Dish



Existing Weather Station



Existing Windmill or Tower



Reinforced Pavement



Continuous Split Barrel Sample



Flight Auger Sample



Split Barrel Sample



Thinwall Tube Sample



Standard Penetration Test



Inclinometer Tube



Excavation Unit



Existing Ground Water Well Bore Hole

NORTH DAKOTA
DEPARTMENT OF TRANSPORTATION

07-01-14

REVISIONS

















































































DATE	CHANGE
12-18-20	General Revisions



12 18 2020

SYMBOLS

D-101-32

 Existing Luminaire  Luminaire LED  Existing Light Standard Luminaire  Relocate Light Standard  Light Standard Light LED Luminaire  Light Standard 35 Watt High Pressure Sodium Vapor Luminaire  Light Standard 50 Watt High Pressure Sodium Vapor Luminaire  Light Standard 70 Watt High Pressure Sodium Vapor Luminaire  Light Standard 100 Watt High Pressure Sodium Vapor Luminaire  Light Standard 150 Watt High Pressure Sodium Vapor Luminaire  Light Standard 200 Watt High Pressure Sodium Vapor Luminaire  Light Standard 250 Watt High Pressure Sodium Vapor Luminaire  Light Standard 310 Watt High Pressure Sodium Vapor Luminaire  Light Standard 400 Watt High Pressure Sodium Vapor Luminaire  Light Standard 700 Watt High Pressure Sodium Vapor Luminaire  Light Standard 1000 Watt High Pressure Sodium Vapor Luminaire  Emergency Vehicle Detector  Video Detection Camera	  High Mast Light Standard 3 Luminaire (Exst, Ppsd)   High Mast Light Standard 4 Luminaire (Exst, Ppsd)   High Mast Light Standard 5 Luminaire (Exst, Ppsd)   High Mast Light Standard 6 Luminaire (Exst, Ppsd)   High Mast Light Standard 7 Luminaire (Exst, Ppsd)   High Mast Light Standard 8 Luminaire (Exst, Ppsd)   High Mast Light Standard 9 Luminaire (Exst, Ppsd)   High Mast Light Standard 10 Luminaire (Exst, Ppsd)   Overhead Sign Structure Load Center (Exst, Ppsd)   Traffic Signal Controller (Exst, Ppsd)   Pad Mounted Traffic Signal Controller (Exst, Ppsd)   Flashing Beacon (Exst, Ppsd)   Concrete Foundation (Exst, Ppsd)   Pipe Mounted Flasher (Exst, Ppsd)   Pad Mounted Feed Point (Exst, Ppsd)   Pipe Mounted Feed Point with Pad (Exst, Ppsd)   Pole Mounted Feed Point (Exst, Ppsd)   Junction Box (Exst, Ppsd)  Existing Pedestrian Head with Number  Existing Signal Head  Pole Mounted Head  Existing Lighting Standard Pole	 Existing Traffic Signal Standard    Pull Box (Exst-Ppsd-Undefined)   Intelligent Transportation Pull Box (Exst, Ppsd)   Transformer (Exst, Ppsd)    Power Pole (Exst-Ppsd-with Transformer)   Wood Pole (Exst, Ppsd)   Pedestrian Push Button Post (Exst, Ppsd)  Existing Pole  Existing Telephone Pole  Existing Post     Connection Conductor (Ground, Neutral, Phase 1, Phase 2)
---	---	--

NORTH DAKOTA DEPARTMENT OF TRANSPORTATION	
07-01-14	
REVISIONS	
DATE	CHANGE
12-18-20	General Revisions



KIRK J. HOFF
REGISTERED
PROFESSIONAL
ENGINEER
NORTH DAKOTA
12 18 2020

SYMBOLS

D-101-33

				Existing Manhole (Electrical, Gas, Telephone)		
				Water Manhole (Exst, Exst with Valve)		
				Sanitary Sewer Manhole (Exst, Ppsd, Exst with Valve)		
				Sanitary Force Main Manhole (Exst, Ppsd, Exst with Valve)		
				Storm Drain Manhole (Exst, Ppsd, Exst with Inlet, Ppsd with Inlet)		
				Force Main Storm Drain Manhole (Exst, Exst with Valve)		
				Manhole (Ppsd, Ppsd 48 Inch, Exst Undefined)		
				Existing Water Appurtenance		
				Sprinkler Head (Exst, Ppsd)		
				Fire Hydrant (Exst, Ppsd)		
				Cleanout (Exst Sanitary, Underdrain)		
				Existing Catch Basin Inlet (Round, Square)		
				Existing Curb Inlet (Round, Square)		
				Existing Slotted Reinforced Concrete Pipe		
				Catch Basin (Riser 30 Inch, Beehive, Type A)		
				Inlet Mountable Curb (Type A, Type B)		
				Inlet Saddle Base (Type 1, Type 2)		
				Inlet Special (Catch Basin, Type 1, Type A)		
				Inlet (Tee, Type 1, Type 2, Type 2 Double)		
				Median Drain		
				Headwall (Exst, Ppsd, Ppsd Single with Vegetation Barrier, Ppsd Double with Vegetation Barrier)		

Cap or Stub
Exst Gas, Exst Sanitary, Exst Storm Drain, Ppsd Storm Drain, Exst Water

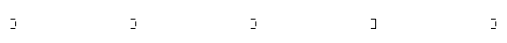

Existing Pedestal
Electrical, Telephone, Fiber Optic Telephone, TV, Fiber Optic TV, Undefined



Existing Pipe Vent
Gas, Fuel, Sanitary, Storm Drain, Water, Undefined



Valve
Exst Gas, Exst Water, Ppsd Water, Exst Undefined



Pump
Sanitary, Storm Drain, Exst Water



Corrugated Metal End Section (18, 24, 30, 36, 42, 48, 54, 60 Inch)



Reinforced Concrete End Section (18, 24, 30, 36, 42, 48, 54, 60 Inch)



Existing Utility Marker

Existing Meter

Existing Fuel Dispensers

Existing Fuel Filler Pipes

Existing Fuel Leak Sensors

NORTH DAKOTA DEPARTMENT OF TRANSPORTATION	
07-01-14	
REVISIONS	
DATE	CHANGE
12-18-20	General Revisions Sheet added - Continued from D-101-32

KIRK J. HOFF
REGISTERED
PROFESSIONAL
ENGINEER
NORTH DAKOTA
12 18 2020

Cross Section Legend

D-101-40

Description	Longitudinal Parallel to Roadway	Transverse Perpendicular to Roadway*
Cable Line	● CBL1	● CBL2
Conduit Line	● CDU1	● CDU2
Electric Line	● E1	● E2
Fiber Optic Line	● F1	● F2
Gas Main Line	● GM1	● GM2
Gas Service Line	● GS1	● GS2
Gas Transmission Line	● GT1	● GT2
Fuel Pipeline	● PL1	● PL2
Sanitary Sewer Force Main	● SSF1	● SSF2
Sanitary Sewer	● SS1	● SS2
Steam Line	● STE1	● STE2
Storm Drain (Assumed Depth)	● SD1	● SD2
Telephone Line	● T1	● T2
TV Line	● TV1	● TV2
Water Main Line	● WM1	● WM2
Water Service Line	● WS1	● WS2

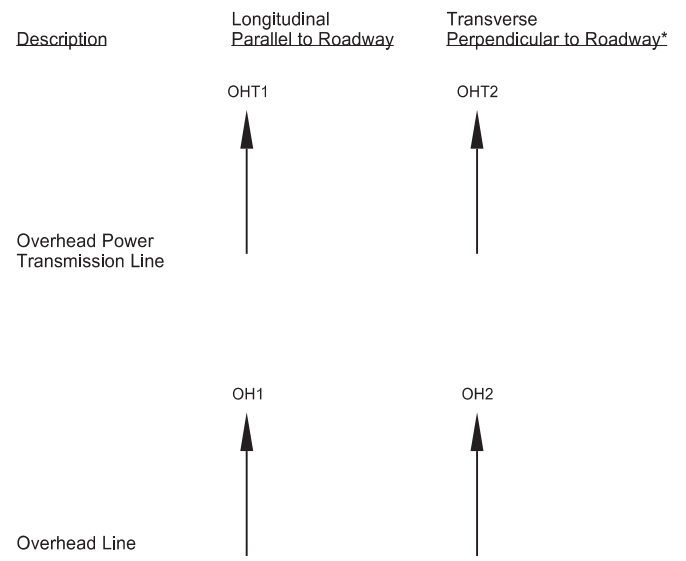

Light Standard - Multiple Variations
Concrete
Steel
Wood
with Traffic Signal

Pole - Multiple Variations
Utility
Brace
Feed Point
Guy
Power
Power Structure
Power with Light
Power with Transformer

Manhole - Multiple Variations
Electric
Fiber Optic
Gas
Inlet
Sanitary Force Main
Sanitary
Sanitary with Valve
Steam
Storm
Storm Force Main
Storm with Valve
Telephone
Water
Water with Meter
Water with Valve
Water with Air Release Valve

Anchor

High Tension Cable Guardrail

* Usually the transverse utilities are shown on a cross section with 2 or more symbols. The utility runs from one symbol to the other, but the connection may not be shown.

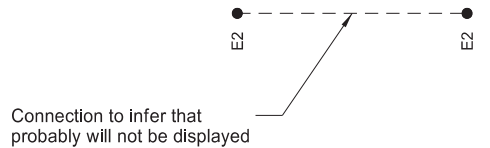

When storm drain invert elevations are NOT used to draw pipe, they will appear as shown to the left. When invert elevations are used to draw pipe, they will be a cross section similar to the graphics shown below.

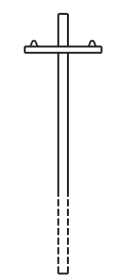

NORTH DAKOTA DEPARTMENT OF TRANSPORTATION	
9-20-18	
REVISIONS	
DATE	CHANGE
6/14/2023	CADD Standards Update



06/14/23

EROSION AND SILTATION CONTROLS - SILT FENCE

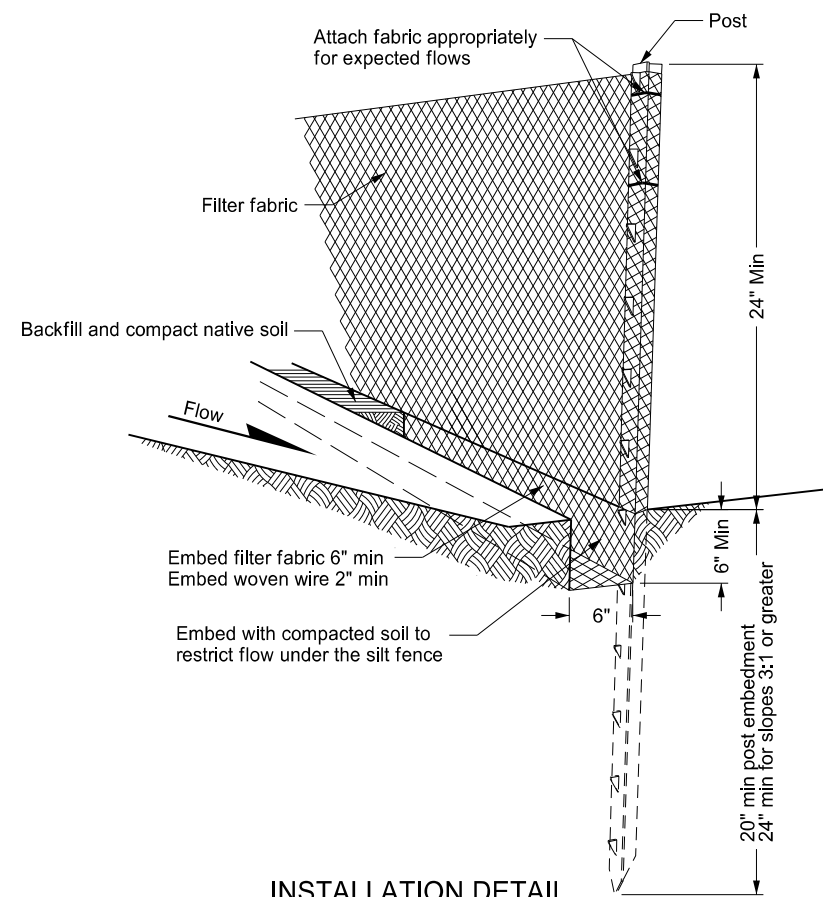

INSTALLATION DETAIL

Minimize disturbance of ground around trench and smooth surface after excavation to avoid concentrating flows. Compact to prevent undercutting flows.

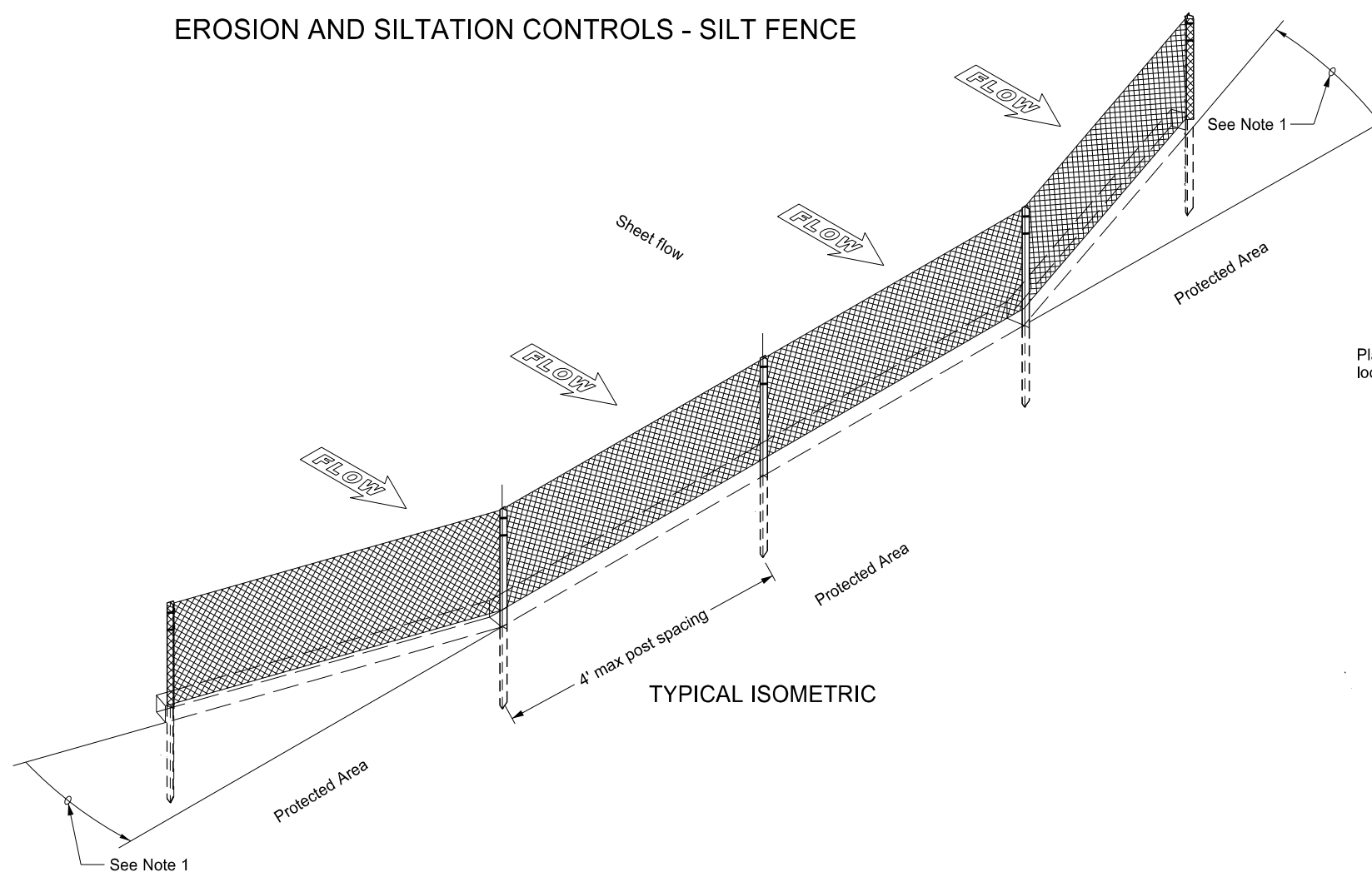

TYPICAL ISOMETRIC

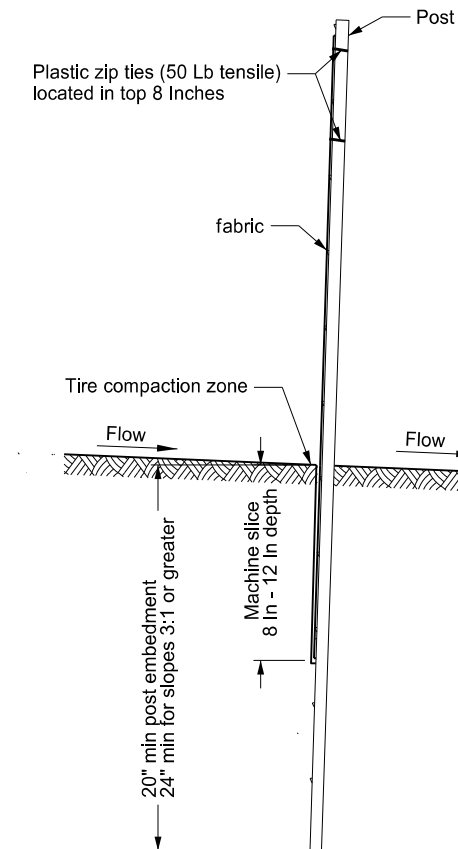

MACHINE SLICED SILT FENCE

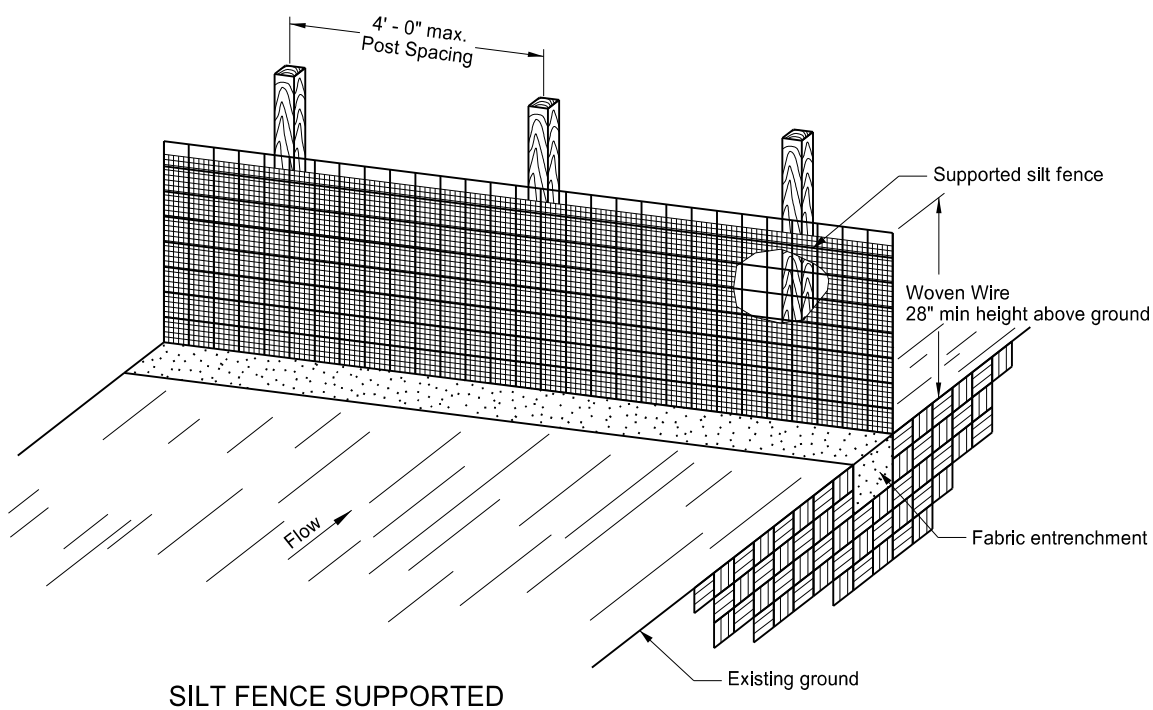

SILT FENCE SUPPORTED

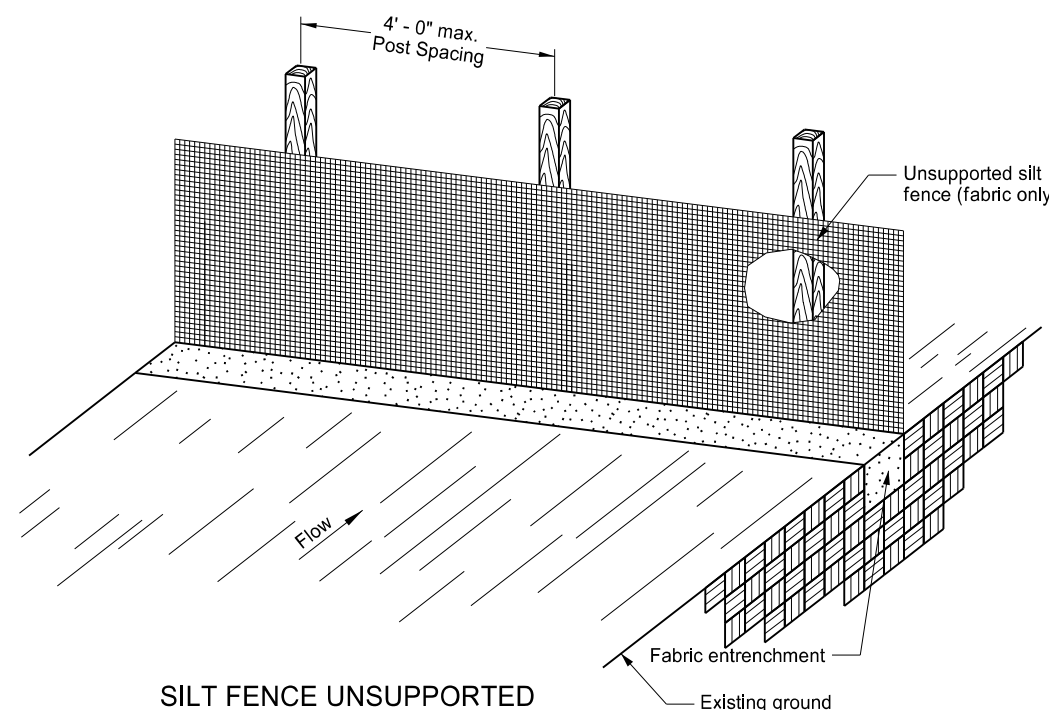

SILT FENCE UNSUPPORTED

- NOTES:
1. Install the ends of the silt fence to point slightly upslope to prevent sediment from flowing around the ends of the fence.
 2. Place splices outside low spots.
 3. Install silt fencing parallel to contour lines.
 4. Do not embed silt fence when placed in standing water.
 5. Silt fence material does not need to reach the top of woven wire support.

NORTH DAKOTA DEPARTMENT OF TRANSPORTATION	
10-03-13	
REVISIONS	
DATE	CHANGE
06-26-14	Standard drawing resulted from splitting standard D-708-2.
06-27-16 08-27-19	Revised details & added new ones. New Design Engineer PE Stamp.

This document was originally issued and sealed by
Kirk J Hoff,
Registration Number
PE- 4683,
on 08/27/19 and the original document is stored at the North Dakota Department of Transportation

EROSION CONTROL
FIBER ROLL PLACEMENT DETAILS

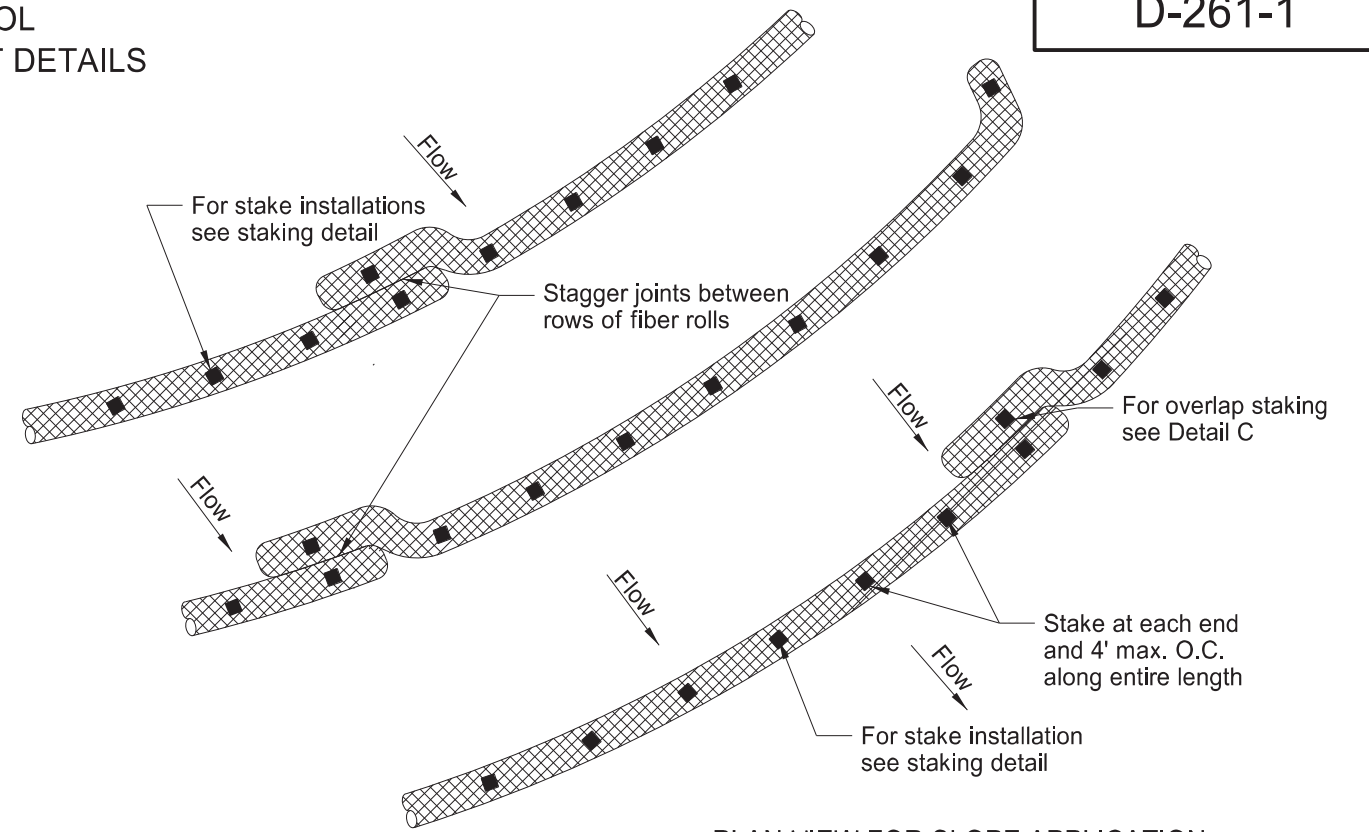
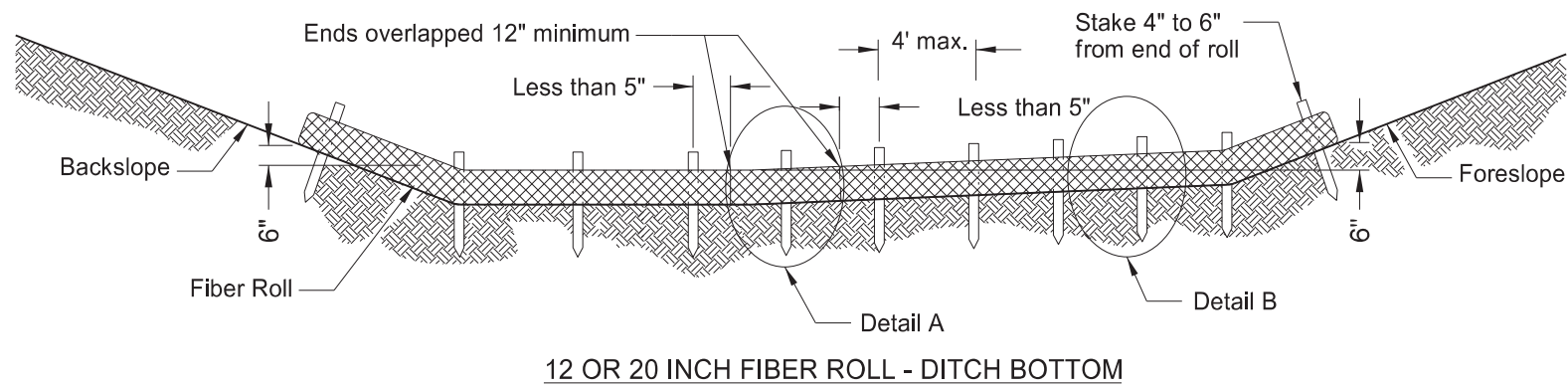

PLAN VIEW FOR SLOPE APPLICATION
Ensure fiber rolls are placed along the contours of the slope.

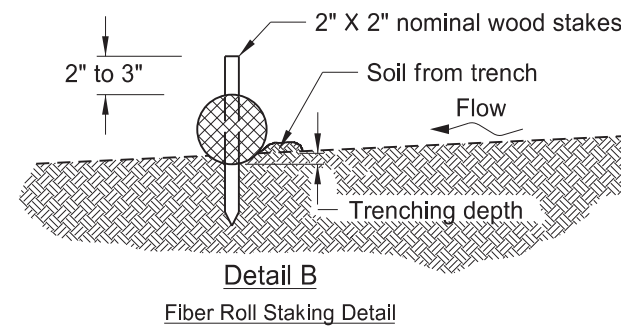
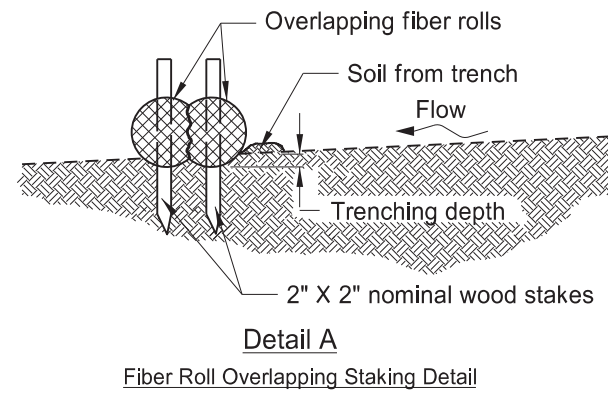
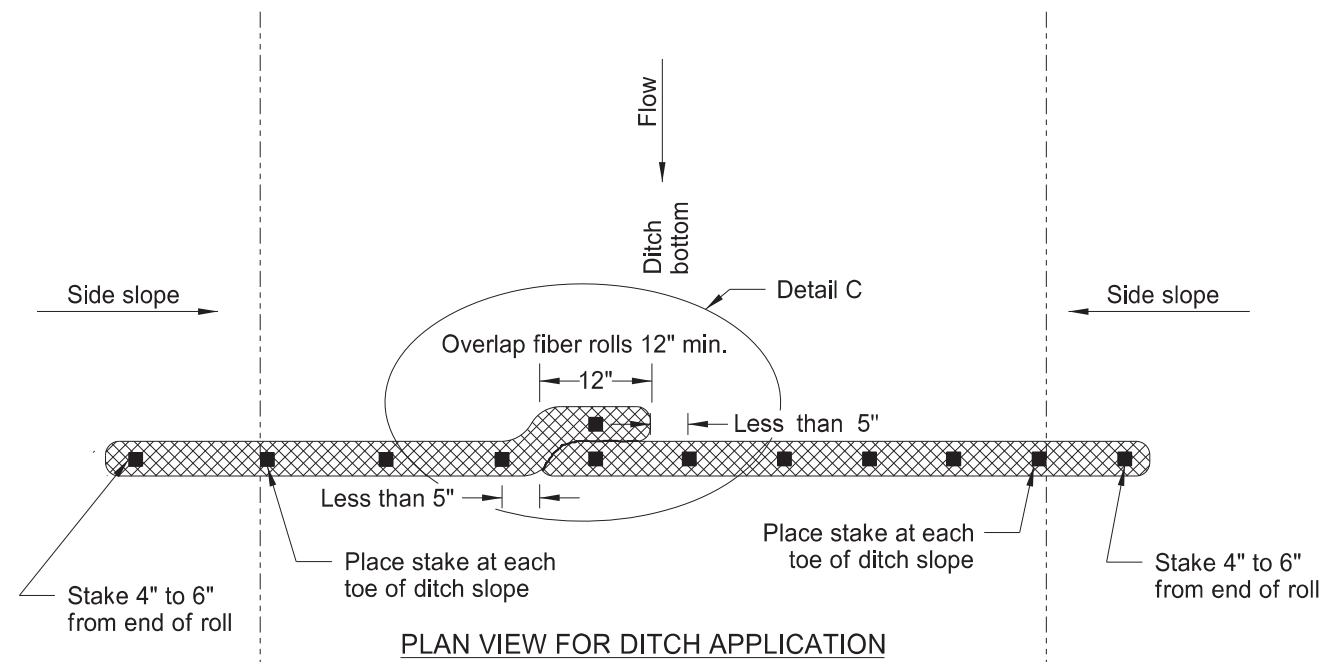

FIBER ROLL DIAMETER	NOMINAL STAKE SIZE	MINIMUM STAKE LENGTH	MINIMUM TRENCH DEPTH	MAXIMUM TRENCH DEPTH
6"	2" x 2"	18"	2"	2"
12"	2" x 2"	24"	2"	3"
20"	2" x 2"	36"	3"	5"

NOTE: Runoff must not be allowed to run under or around roll.

NORTH DAKOTA DEPARTMENT OF TRANSPORTATION	
11-18-10	
REVISIONS	
DATE	CHANGE
06-10-13	Added plan view for ditch and slope application. Added table with values for stake and trench dimensions.
10-04-13	Revised fiber roll overlap detail.
06-26-14	Changed standard drawing number from D-708-7 to D-261-1.
08-27-19	New Design Engineer PE Stamp
04-22-24	Slope Plan View-Overlap Change.



04/22/24

BREAKAWAY SYSTEMS FOR CONSTRUCTION ZONE SIGNS

D-704-7

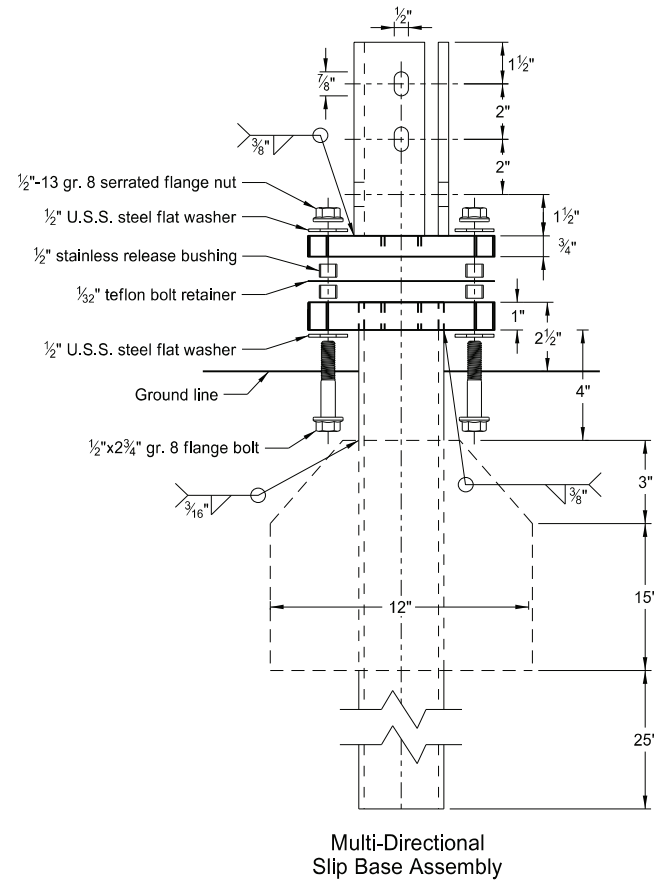

Perforated Tube

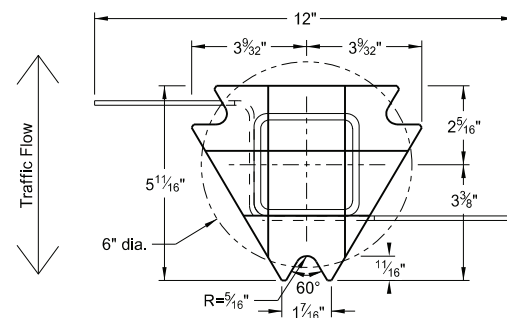
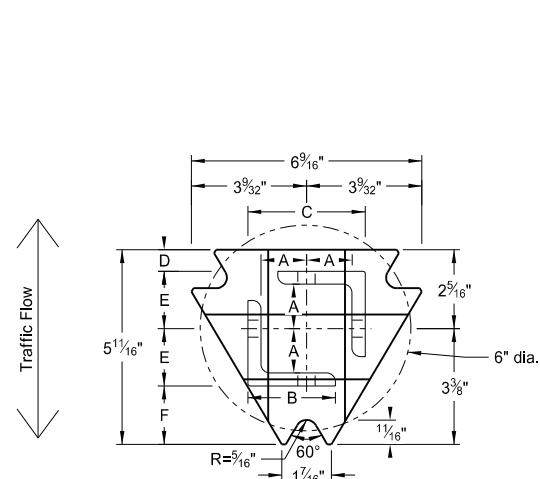

Bottom Soil Stub

Tube - 3"x3"x7 gauge ASTM A500 grade B tube
Stabilizing Wing - 7 gauge H.R.P.O. ASTM A1011
Plate - ASTM A572 grade 50

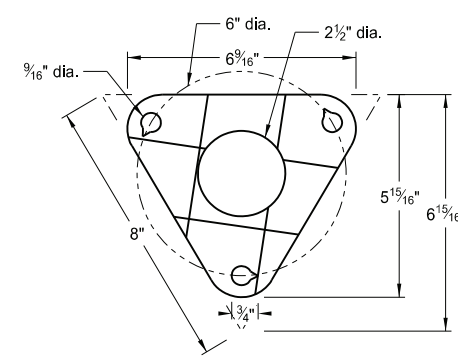

Bolt Retainer for Base Connection

Bolt Retainer - 1/2" Reprocessed Teflon

Notes:

1. Torque slip base bolts as specified by manufacturer.
2. Use anchor with 43.9 KSI yield strength and 59.3 KSI tensile strength.
3. Provide 4" vertical clearance for anchor or breakaway base. Measure the 4"x60" measurement above and below post location and back and ahead of post.
4. In concrete sidewalk, use same anchor without wings.
5. Provide more than 7' between the first and fourth posts of a four post sign.

Telescoping Perforated Tube

Number of Posts	Post Size in.	Wall Thickness Gauge	Sleeve Size in.	Wall Thickness Gauge	Slip Base	Anchor Size without Slip Base in.
1	2	12			No	2 1/4
1	2 1/4	12			No	2 1/2
1	2 1/2	12			(A)	3
1	2 1/2	10			Yes	
1	2 1/4	12	2	12	Yes	
1	2 1/2	12	2 1/4	12	Yes	
2	2	12			No	2 1/4
2	2 1/4	12			No	2 1/2
2	2 1/2	12			Yes	
2	2 1/2	12			Yes	
2	2 1/4	10	2	12	Yes	
3 & 4	2 1/2	12			Yes	
3 & 4	2 1/2	10			Yes	
3 & 4	2 1/2	12	2 1/4	12	Yes	
3 & 4	2 1/4	12	2	12	Yes	
3 & 4	2 1/2	10	2 3/16	10	Yes	

Properties of Telescoping Perforated Tube

Tube Size in.	Wall Thickness in.	U.S. Standard Gauge	Weight per Foot lbs.	Moment of Inertia in. ⁴	Cross Sec. Area in. ²	Section Modulus in. ³
1 1/2 x 1 1/2	0.105	12	1.702	0.129	0.380	0.172
2 x 2	0.105	12	2.416	0.372	0.590	0.372
2 1/4 x 2 1/4	0.105	12	2.773	0.561	0.695	0.499
2 3/16 x 2 3/16	0.135	10	3.432	0.605	0.841	0.590
2 1/2 x 2 1/2	0.105	12	3.141	0.804	0.803	0.643
2 1/2 x 2 1/2	0.135	10	4.006	0.979	1.010	0.785

Top Post Receiver Data Table

Square Post Sizes (B)	A	B	C	D	E	F
2 3/16"x10 ga.	1 9/64"	2 1/2"	3 1/32"	2 5/32"	1 33/64"	1 7/8"
2 1/2"x10 ga.	1 3/32"	2 1/2"	3 5/16"	5/8"	1 21/32"	1 3/4"

- (A) Use breakaway base when support is placed in weak soils. Engineer determines if soils are weak.
- (B) For additional wind load, insert the 2 3/16"x10 ga. into 2 1/2"x10 ga.

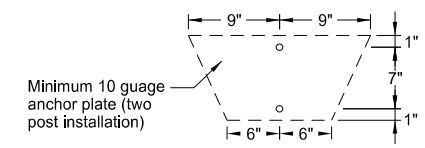
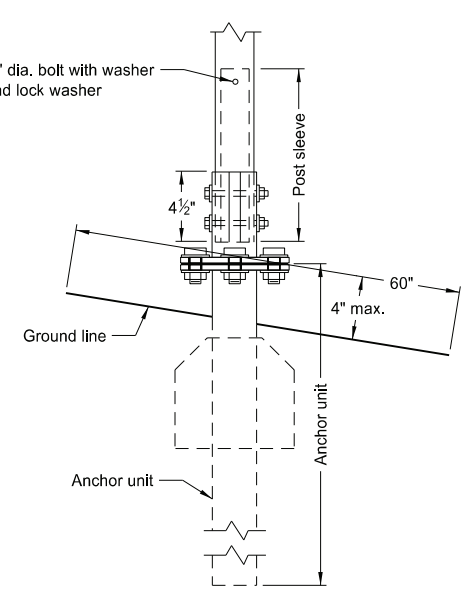
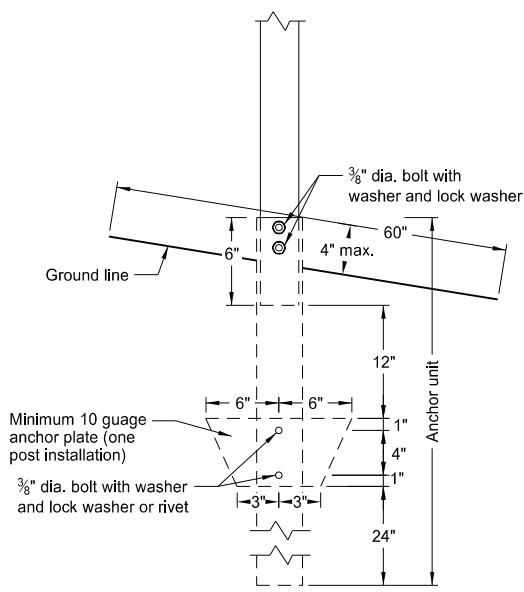

NORTH DAKOTA DEPARTMENT OF TRANSPORTATION	
2-28-14	
REVISIONS	
DATE	CHANGE
9-27-17	Updated to active voice
10-03-19	New Design Engr PE Stamp
8-01-24	Electronic Stamp/Signature



08/01/24

BREAKAWAY SYSTEMS FOR CONSTRUCTION ZONE SIGNS

D-704-8

U-Channel Post

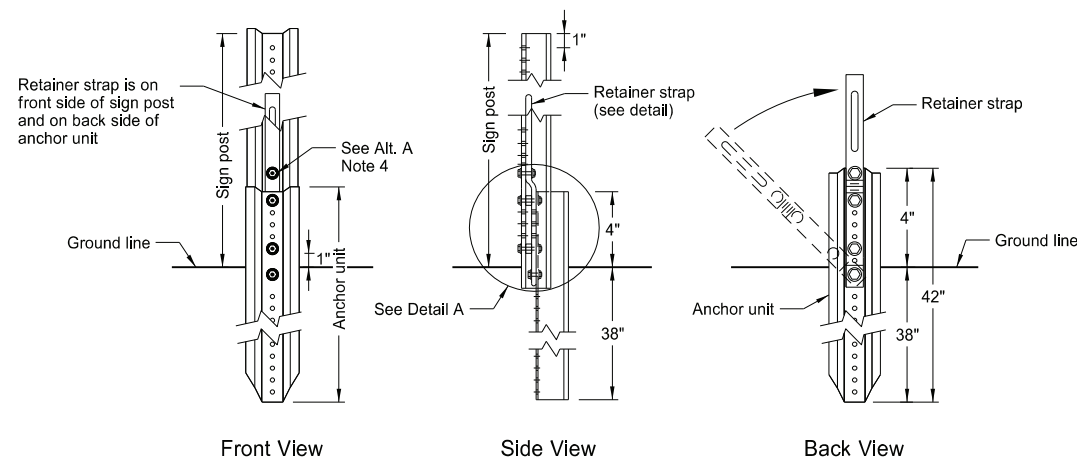
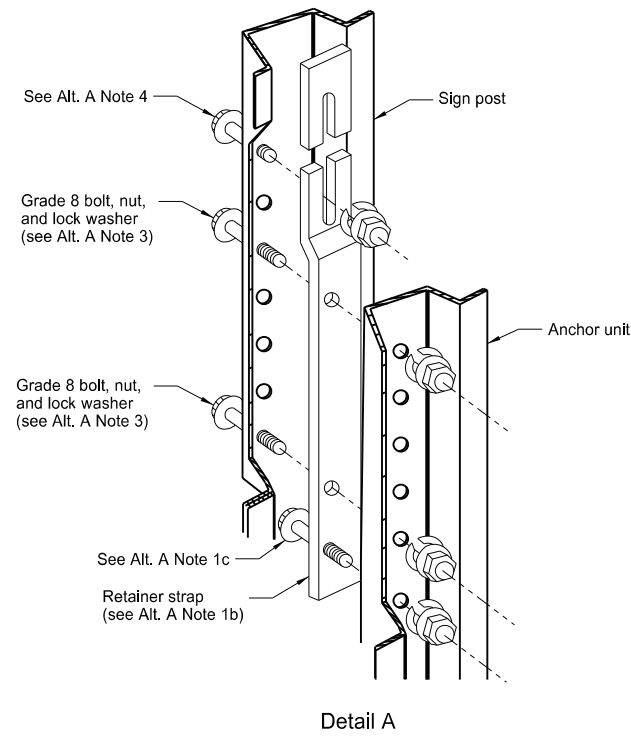

Breakaway U-Channel Detail Alternate A
Install a maximum of 2 posts within 7'.

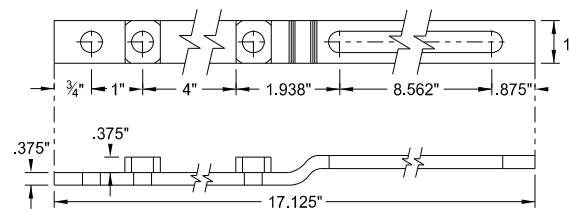

Retainer Strap Detail

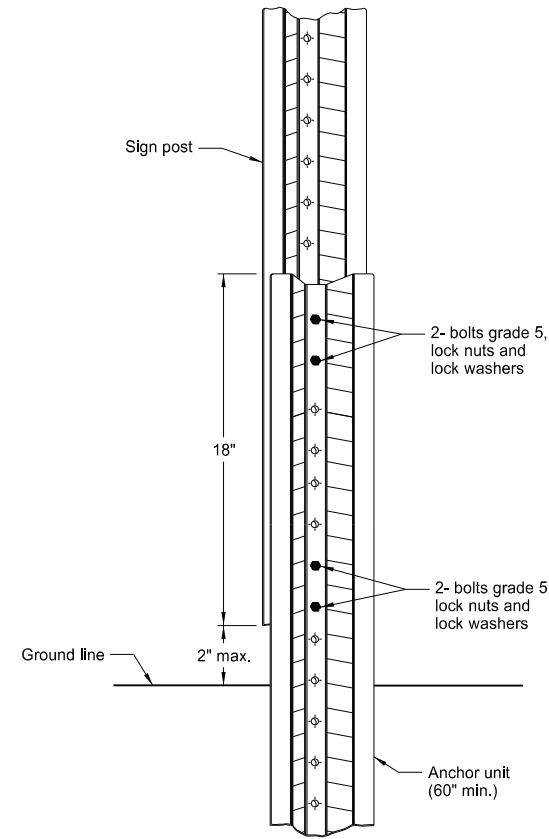

Breakaway U-Channel Splice Detail Alternate B
(2.5 and 3 lb/ft)
Install a maximum of 3 posts within 7'.

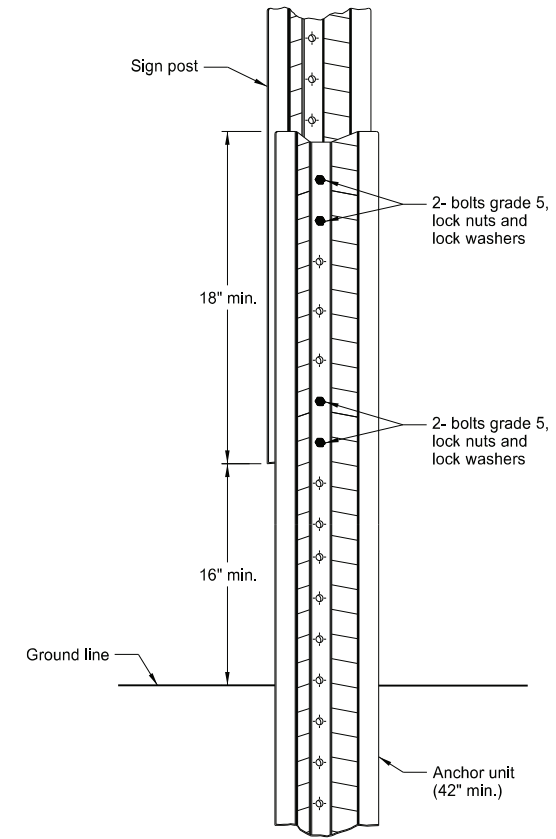

Breakaway U-Channel Splice Detail Alternate C
(2.5 and 3 lb/ft)
Install a maximum of 3 posts within 7'.

Alternate A Steps of Installation:

- Drive anchor unit to within 12" of ground level.
 - Establish proper assembly by lining up bottom hole of retainer strap with 6th hole from the top of the anchor unit.
 - Assemble strap to back of anchor unit using 5/16"x2" bolt, lock washer and nut.
 - Rotate strap 90° to left.
- Drive anchor unit to 4" above ground.
 - Rotate strap to vertical position.
- Place 5/16"x2" bolt, lock washer and nut in bottom of sign post to facilitate alignment of sign post with proper hole in anchor unit.
 - Alternately tighten two connector bolts.
- Complete assembly by tightening 5/16"x2" bolt (this fastens sign post to retainer strap).
- Properly nest base post, strap, and sign post. Proper nesting occurs when all flat surfaces of the base post, strap, and sign post at the bolts have full contact across the entire width.

NORTH DAKOTA DEPARTMENT OF TRANSPORTATION	
2-28-14	
REVISIONS	
DATE	CHANGE
9-27-17	Updated to active voice
10-03-19	New Design Engr PE Stamp
8-01-24	Electronic Stamp/Signature



08/01/24

CONSTRUCTION SIGN DETAILS
TERMINAL AND GUIDE SIGNS

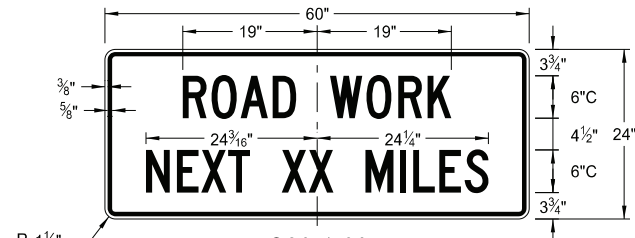

G20-1-60
Legend: black (non-refl)
Background: orange

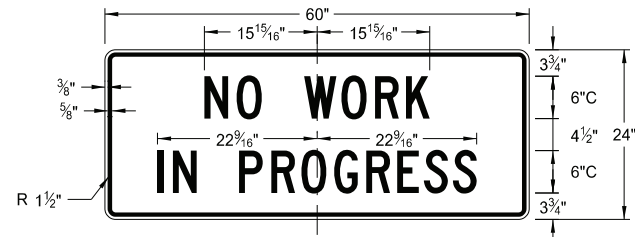

G20-1b-60
Legend: black (non-refl)
Background: orange

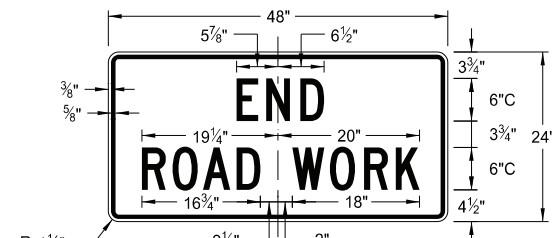

G20-2-48
Legend: black (non-refl)
Background: orange



G20-4b-36
Legend: black (non-refl)
Background: orange

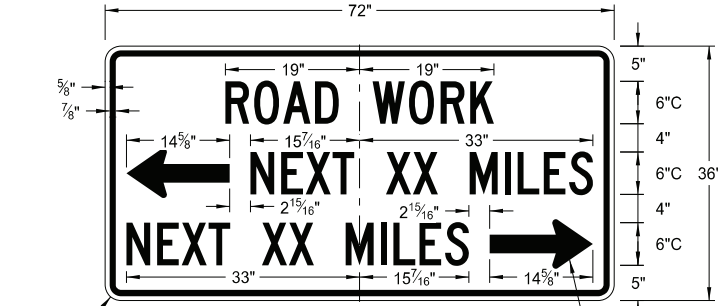

G20-50a-72
Legend: black (non-refl)
Background: orange

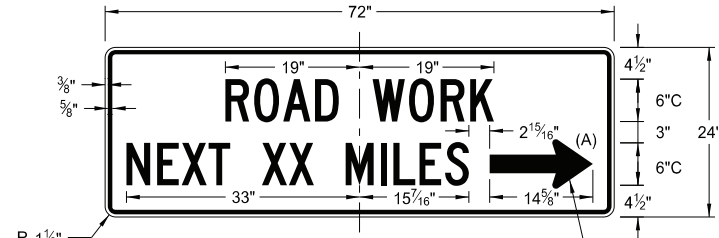

G20-52a-72
Legend: black (non-refl)
Background: orange

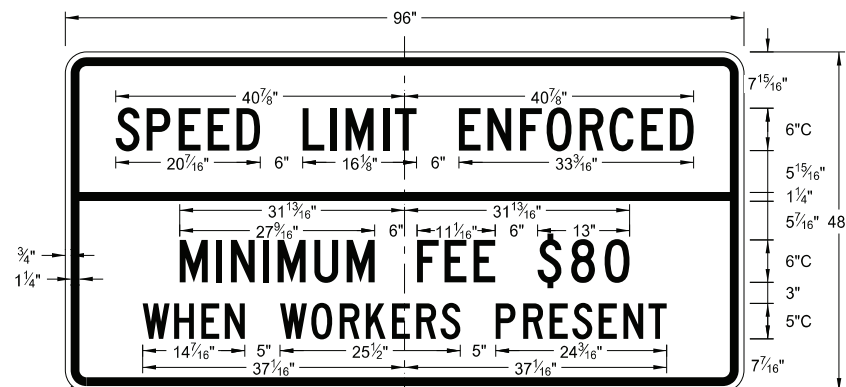

G20-55-96
Legend: black (non-refl)
Background: orange

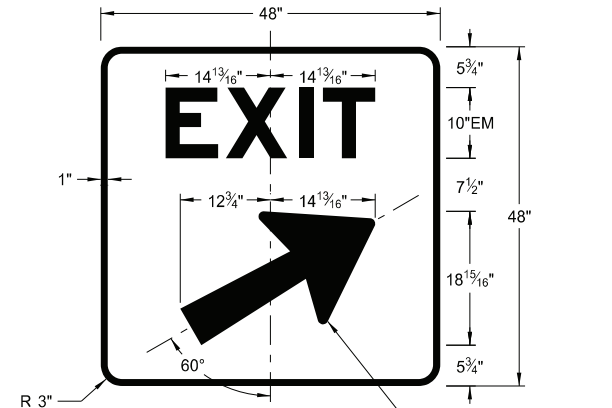

E5-1(L or R)-48
Legend: white
Background: green (orange optional)

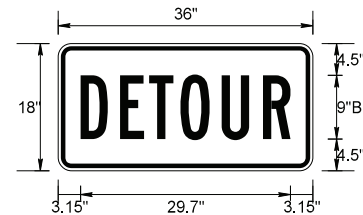

M4-8-36
Legend: black (non-refl)
Background: orange

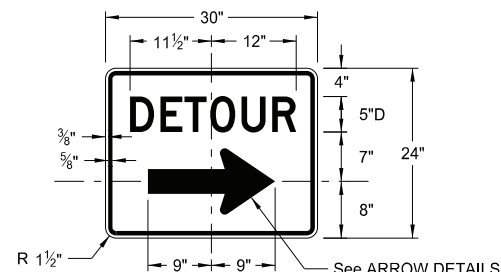

M4-9(L or R)-30 & M4-9-30
Legend: black (non-refl)
Background: orange

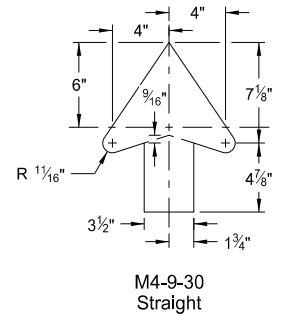
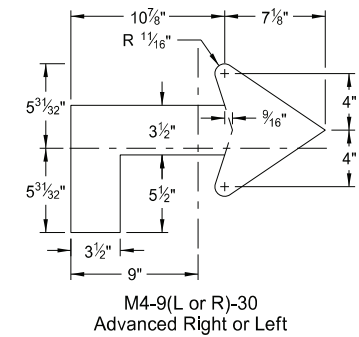
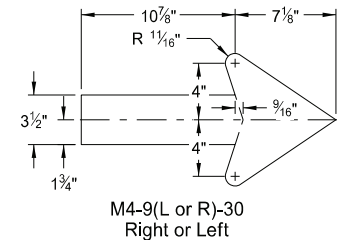
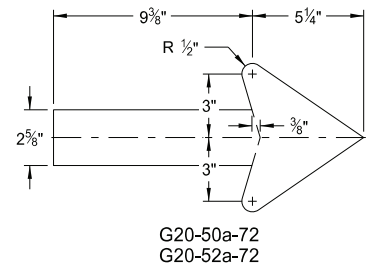
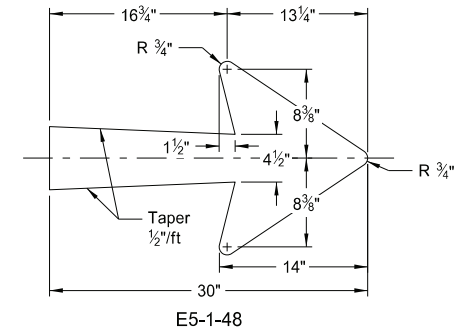

ARROW DETAILS

NOTES:

(A) Arrow may be right or left of the legend to indicate construction to the right or left.

NORTH DAKOTA DEPARTMENT OF TRANSPORTATION 8-13-13	
REVISIONS	
DATE	CHANGE
8-17-17	Added sign & background color
10-03-19	New Design Engineer PE Stamp
8-01-24	Electronic Stamp/Signature



08/01/24

CONSTRUCTION SIGN DETAILS
REGULATORY SIGNS

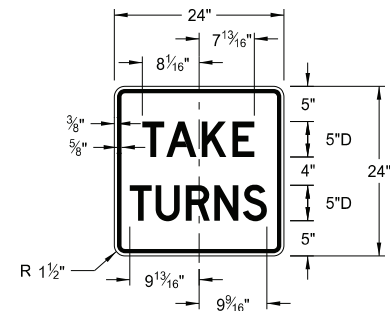

R1-50P-24
Legend: black (non-refl)
Background: white



R11-3c-60
Legend: black (non-refl)
Background: white

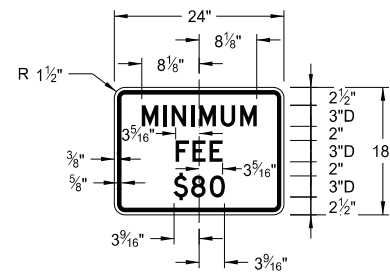

R2-1aP-24
Legend: black (non-refl)
Background: white

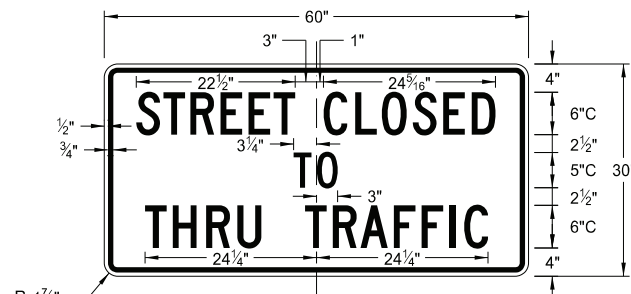

R11-4a-60
Legend: black (non-refl)
Background: white

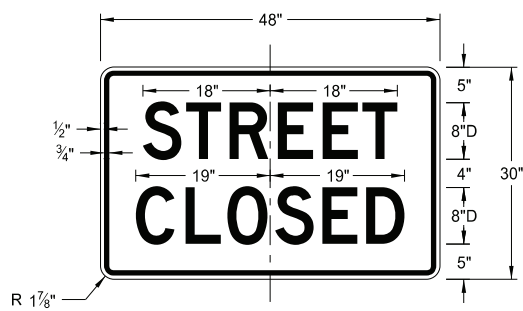

R11-2a-48
Legend: black (non-refl)
Background: white

NORTH DAKOTA DEPARTMENT OF TRANSPORTATION	
8-13-13	
REVISIONS	
DATE	CHANGE
8-17-17	Revised sign number
10-03-19	New Design Engineer PE Stamp
8-01-24	Electronic Stamp/Signature



08/01/24

CONSTRUCTION SIGN DETAILS
WARNING SIGNS

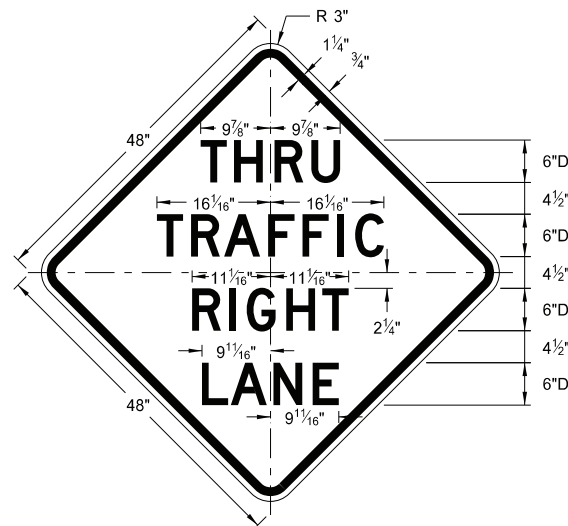

W5-8-48
Legend: black (non-refl)
Background: orange

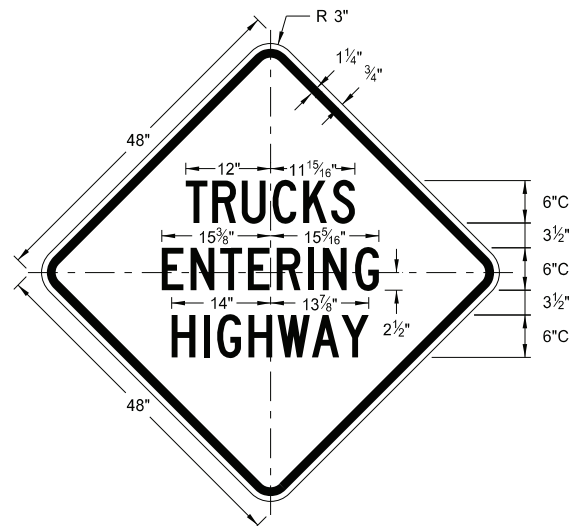

W8-53-48
Legend: black (non-refl)
Background: orange

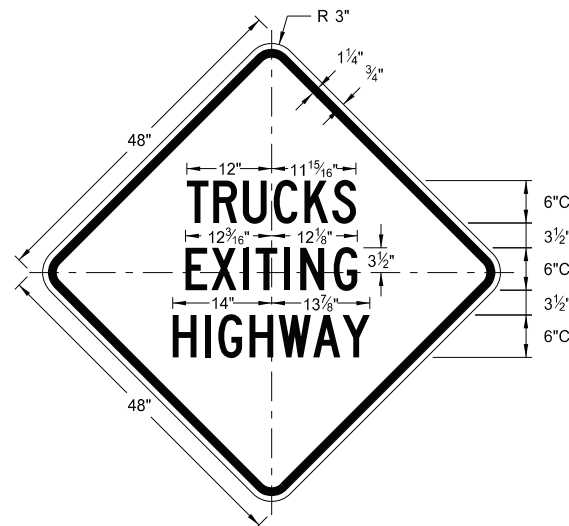

W8-56-48
Legend: black (non-refl)
Background: orange

WORD	LETTER SPACING
AHEAD	Standard
200 FT	Standard
350 FT	Standard
500 FT	Standard
1000 FT	Reduce 40%
1500 FT	Reduce 40%
½ MILE	Reduce 50%
1 MILE	Standard

* DISTANCE MESSAGES

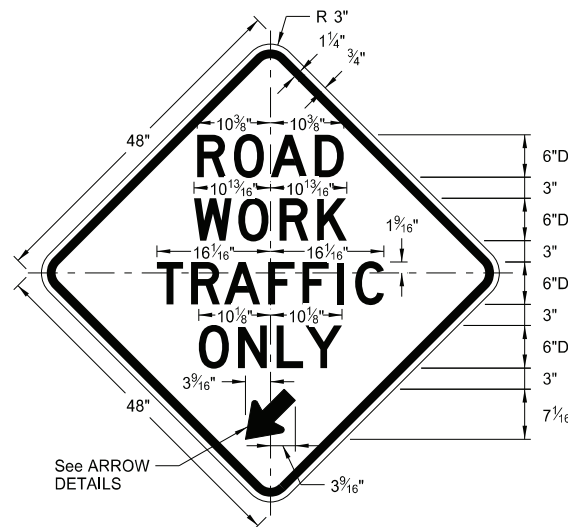

W5-9-48
Legend: black (non-refl)
Background: orange

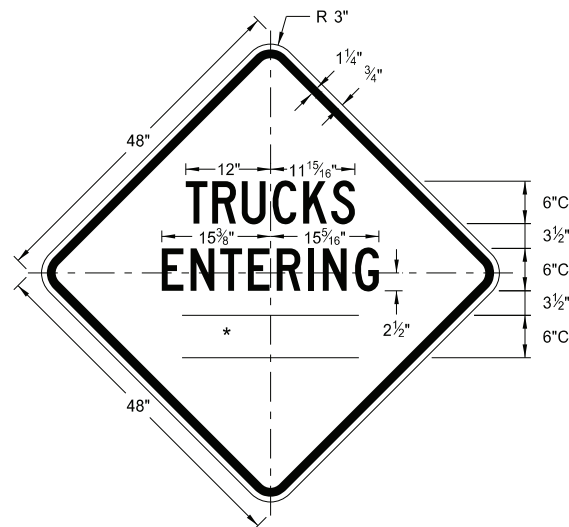

W8-54-48
Legend: black (non-refl)
Background: orange

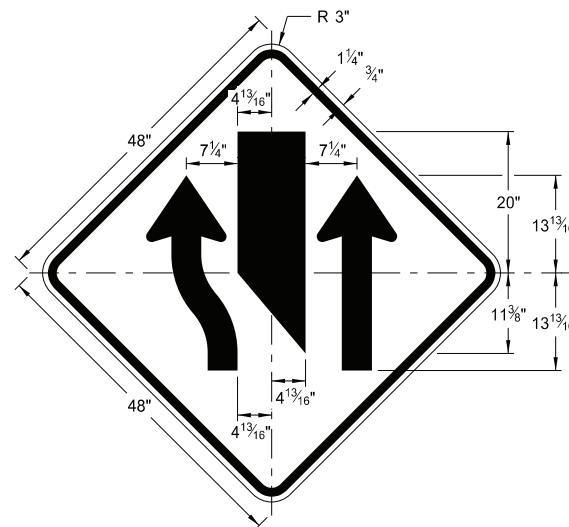

W9-3a-48
Legend: black (non-refl)
Background: orange

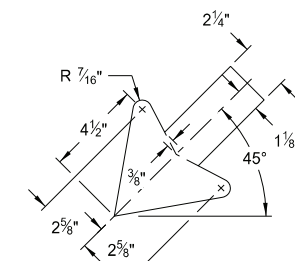

W5-9-48

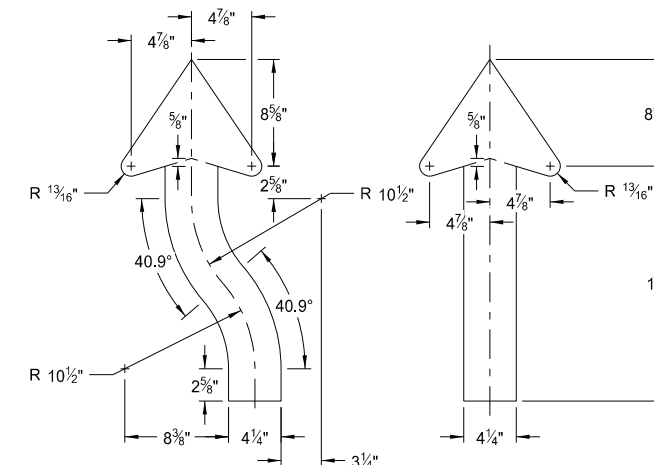

W9-3a-48

ARROW DETAILS

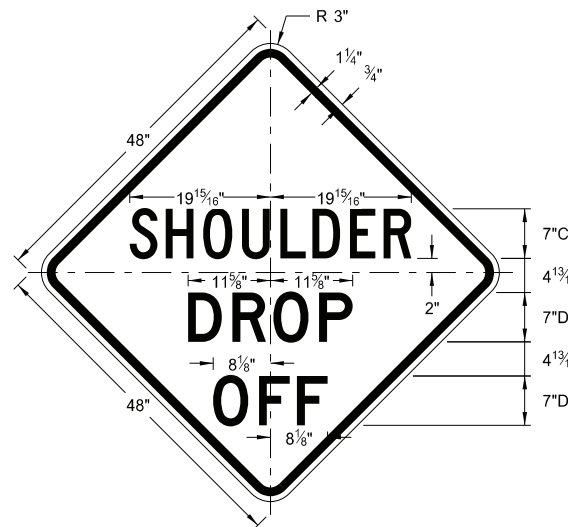

W8-9a-48
Legend: black (non-refl)
Background: orange

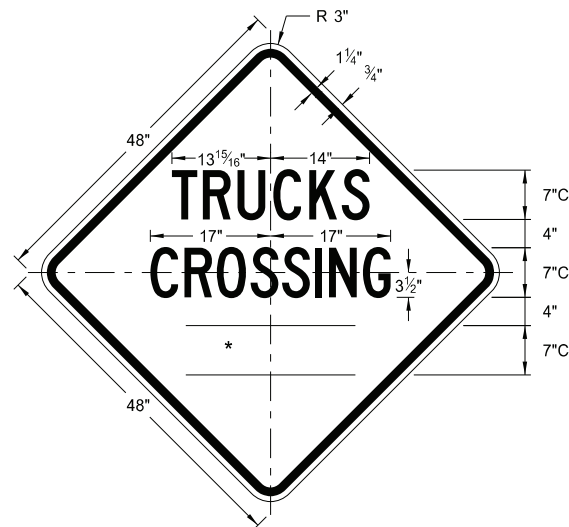

W8-55-48
Legend: black (non-refl)
Background: orange

NORTH DAKOTA DEPARTMENT OF TRANSPORTATION	
8-13-13	
REVISIONS	
DATE	CHANGE
8-17-17	Updated sign number
5-31-18	Revised sign and arrow details
10-03-19	New Design Engineer PE Stamp
8-01-24	Electronic Stamp/Signature



08/01/24

BARRICADE AND CHANNELIZING DEVICE DETAILS

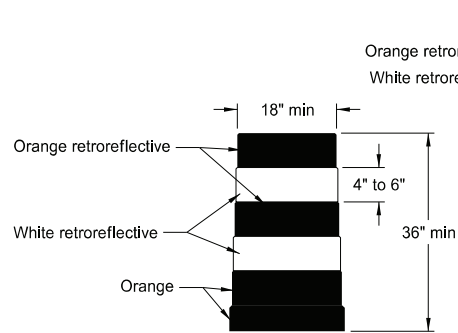

DELINEATOR DRUM

Provide horizontal, circumferential, alternating orange and white retroreflective stripes 4" to 6" wide for drum markings. Use a minimum of two orange and two white stripes with the top stripe being orange for each drum. Do not exceed 3" nonretroreflective spaces between the horizontal orange and white stripes. Avoid placement of stripes on drum ribs or indentations. Use closed top drums that will not allow collection of debris. Do not place ballast on the top of drum.

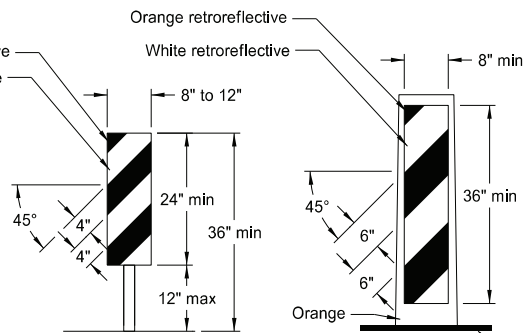

VERTICAL PANEL

Provide alternating orange and white retroreflective stripes, sloping downward in direction vehicular traffic is to pass. Place retroreflective sheeting on both sides of panel with a minimum of 270 square inches of retroreflective area facing vehicular traffic. Where the height of the retroreflective material on the vertical panel is 36 inches or more, use a stripe width of 6 inches.

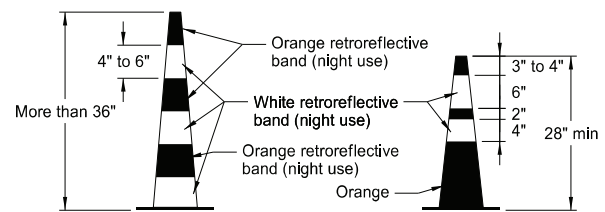

TRAFFIC CONE

Provide retroreflectization of cones more than 36" in height by alternating orange and white retroreflective stripes. Use a minimum of two orange and two white stripes for each cone with the top stripe being orange. Use maximum 3" nonretroreflective space between the orange and white stripes.

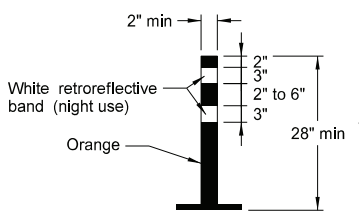

TUBULAR MARKER

Provide retroreflectization of tubular markers more than 42" in height by alternating four 4" to 6" wide orange and white stripes with the top stripe being orange.

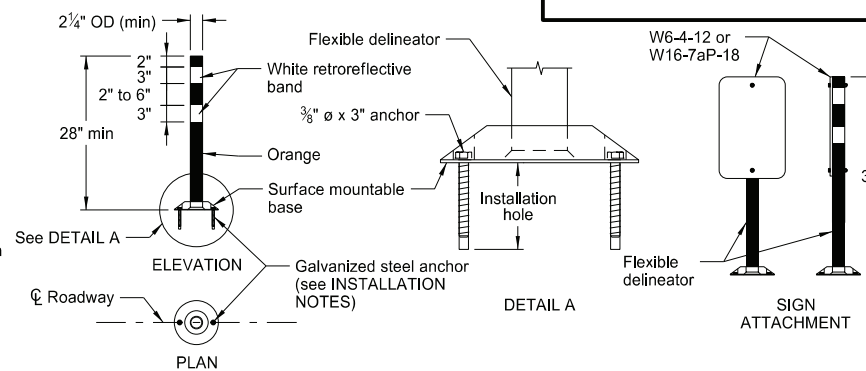

FLEXIBLE DELINEATOR

INSTALLATION NOTES:

1. Drill installation holes to diameter and depth required by manufacturer's specifications.
2. For removal, remove anchors and fill installation hole with an epoxy designed to bond to pavement surface.
3. In lieu of bolted down base, use an 8" x 8" butyl pad or hot melt butyl. Remove butyl as close as possible to pavement surface.

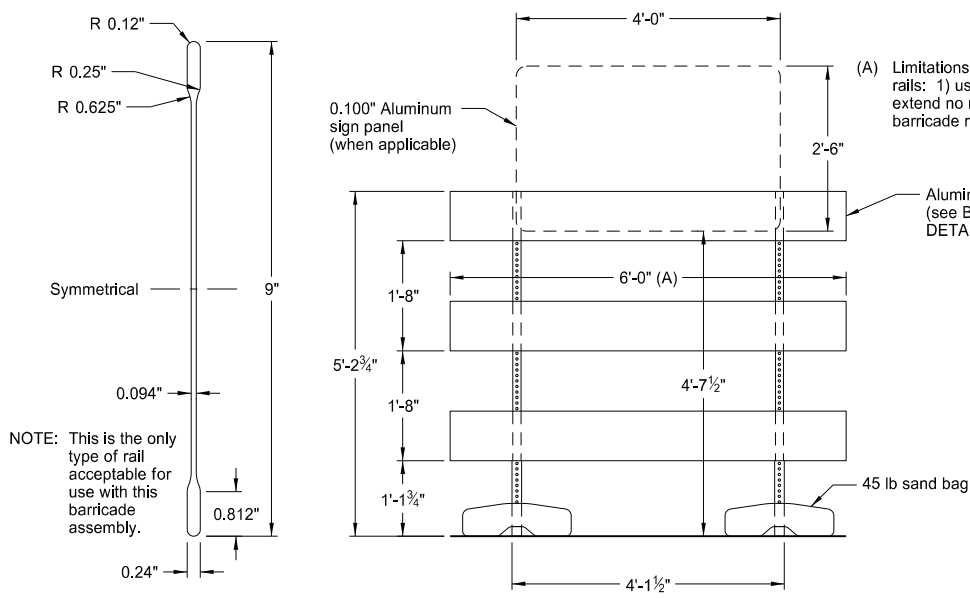

BARRICADE BLADE DETAIL

NOTE: This is the only type of rail acceptable for use with this barricade assembly.

ELEVATION VIEW
BARRICADE ASSEMBLY DETAIL
(Aluminum Barricade Rails)

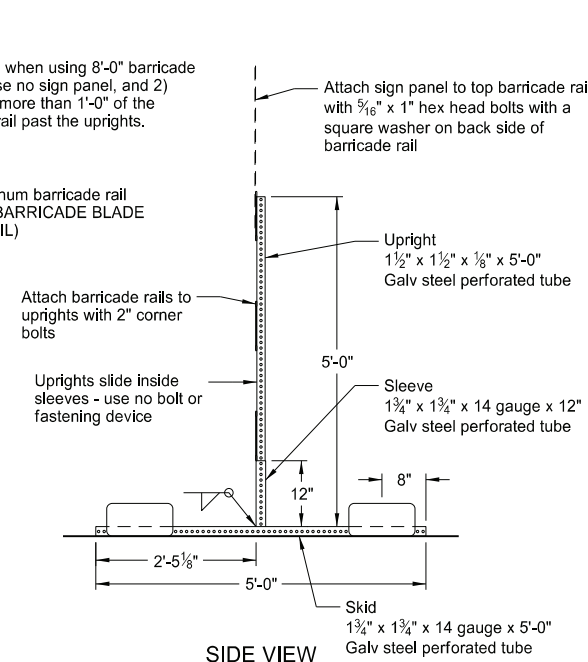

ELEVATION VIEW

BARRICADE ASSEMBLY DETAIL
(Wood or Plastic Rails)

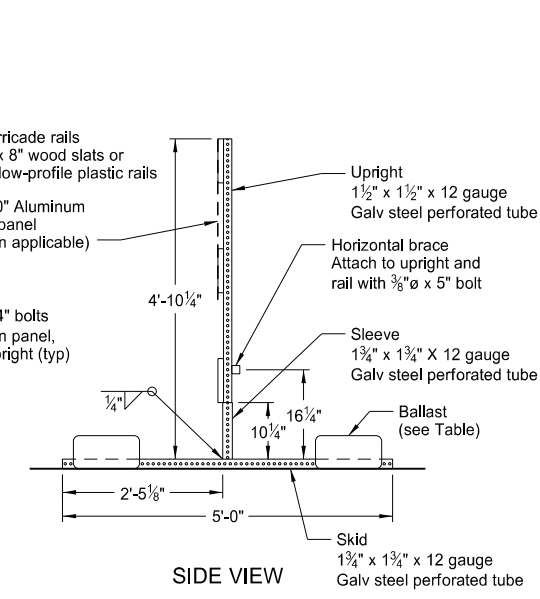

SIDE VIEW

MINIMUM BALLAST
(For each side of barricade support)

Without Sign	4 - 25 lb sandbags
With Sign	6 - 25 lb sandbags

Note: Number of sandbags based on a wind speed of 55 MPH. Sandbags assumed to be placed at or near the ends of the skids.

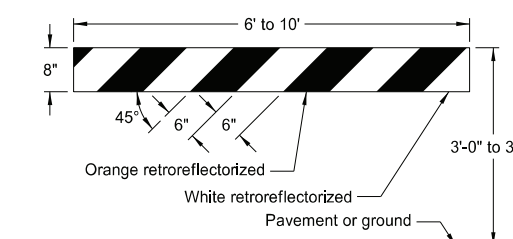

TYPE I BARRICADE

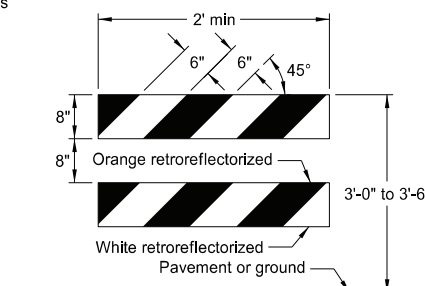

TYPE II BARRICADE

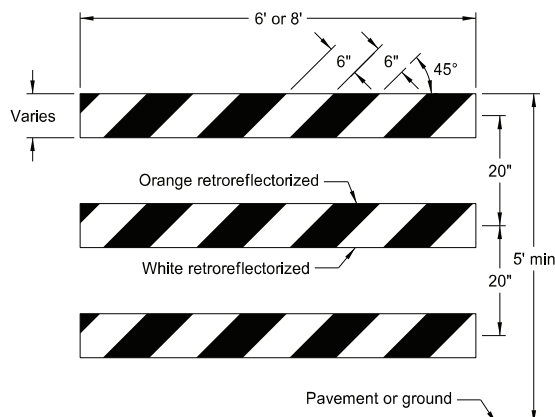

TYPE III BARRICADE

BARRICADE RAIL DETAILS

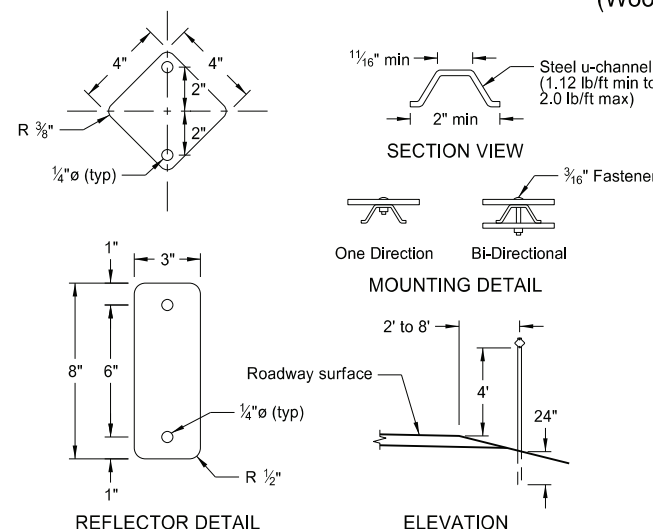

REFLECTOR DETAIL

ELEVATION

DELINEATORS

NORTH DAKOTA DEPARTMENT OF TRANSPORTATION	
10-3-13	
REVISIONS	
DATE	CHANGE
9-27-17	Updated to active voice
11-01-19	Revised details for Flexible Delineator
8-01-24	Electronic Stamp/Signature



08/01/24

CONSTRUCTION SIGN PUNCHING AND MOUNTING DETAILS

Note: In curb sections, place signs a minimum horizontal distance of 2' from face of the curb to near edge of the sign.

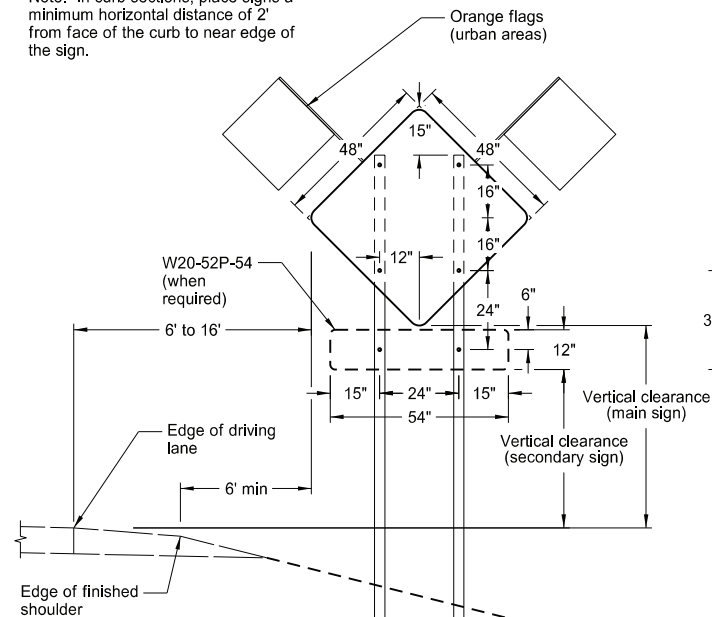

TYPICAL SECTION
(48" x 48" diamond warning sign shown)

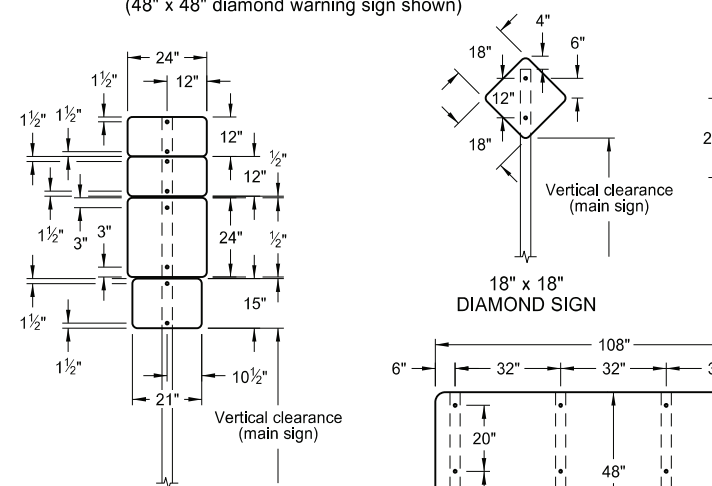

18" x 18" DIAMOND SIGN

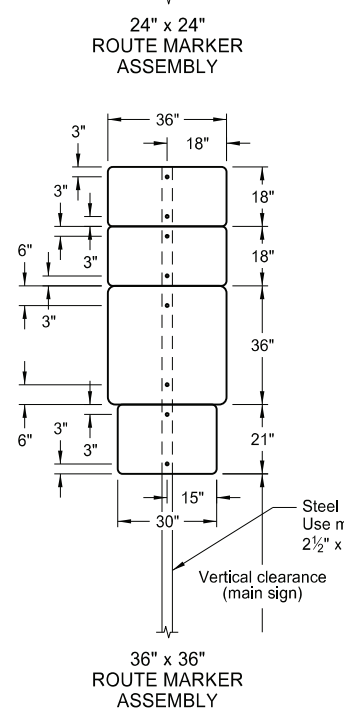

24" x 24" ROUTE MARKER ASSEMBLY

36" x 36" ROUTE MARKER ASSEMBLY

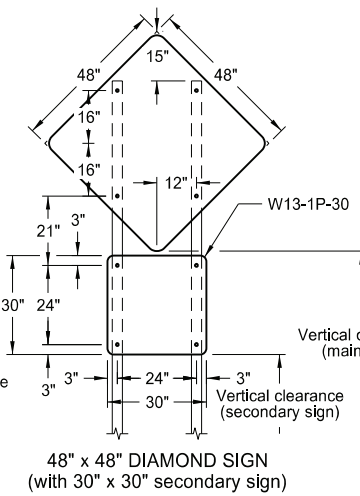

48" x 48" DIAMOND SIGN
(with 30" x 30" secondary sign)

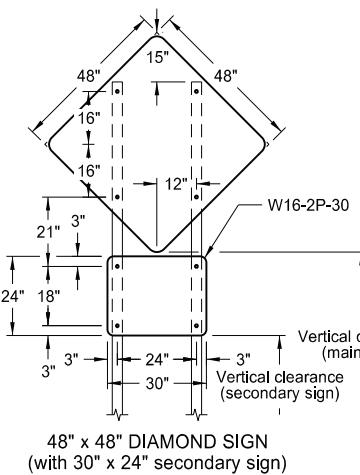

48" x 48" DIAMOND SIGN
(with 30" x 24" secondary sign)

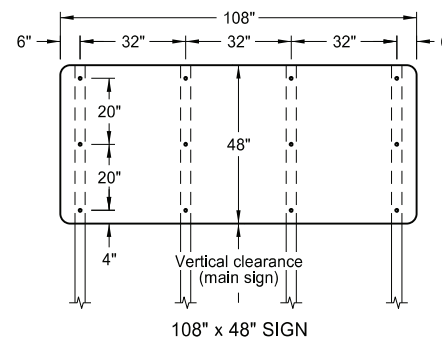

108" x 48" SIGN

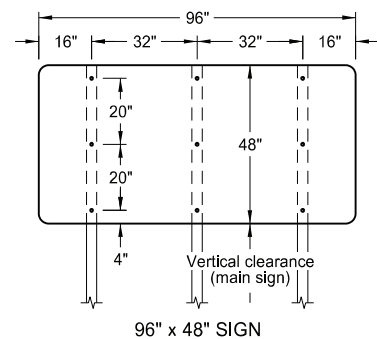

96" x 48" SIGN

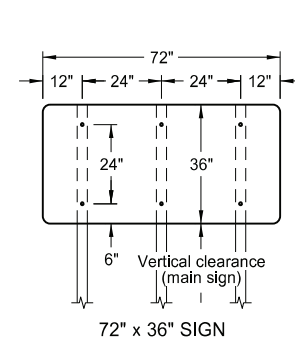

72" x 36" SIGN

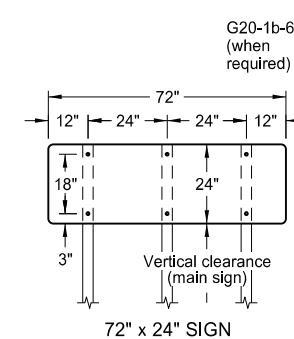

72" x 24" SIGN

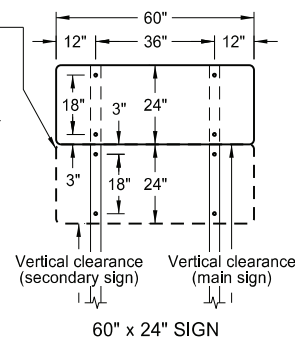

60" x 24" SIGN

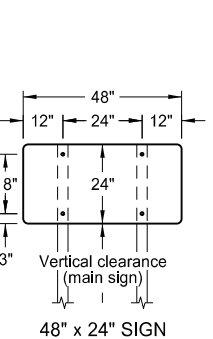

48" x 24" SIGN

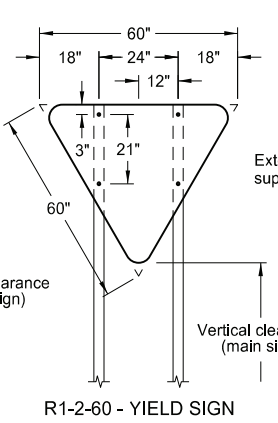

R1-2-60 - YIELD SIGN

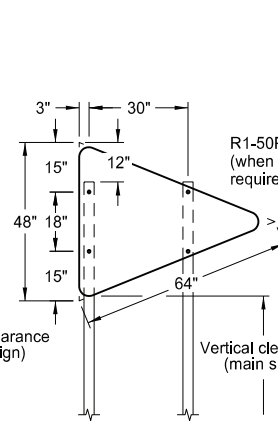

W14-3-64 - PENNANT SIGN

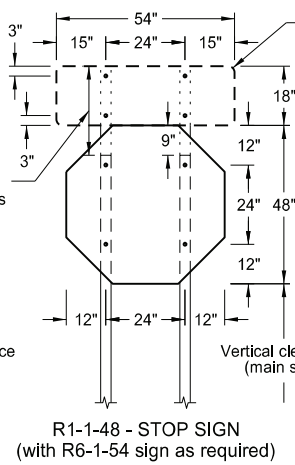

R1-1-48 - STOP SIGN
(with R6-1-54 sign as required)

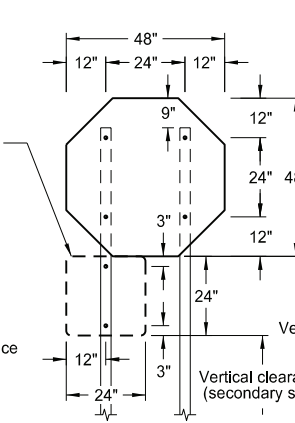

R1-1-48 - STOP SIGN
(with R1-50P-24 sign as required)

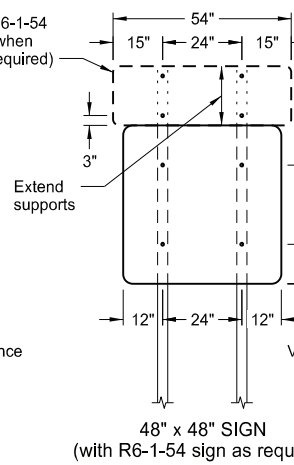

48" x 48" SIGN
(with R6-1-54 sign as required)

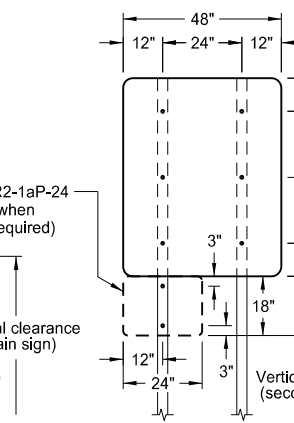

48" x 48" SIGN
(with R2-1aP-24 sign as required)

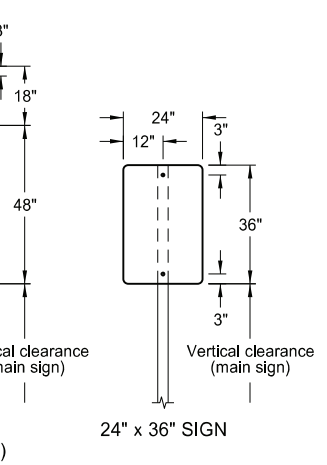

24" x 36" SIGN

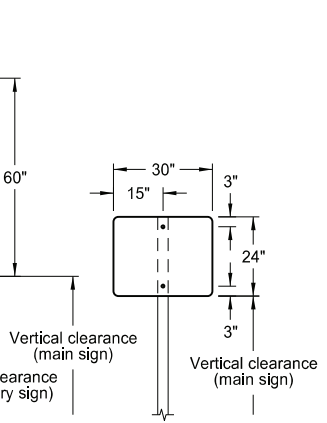

30" x 24" SIGN

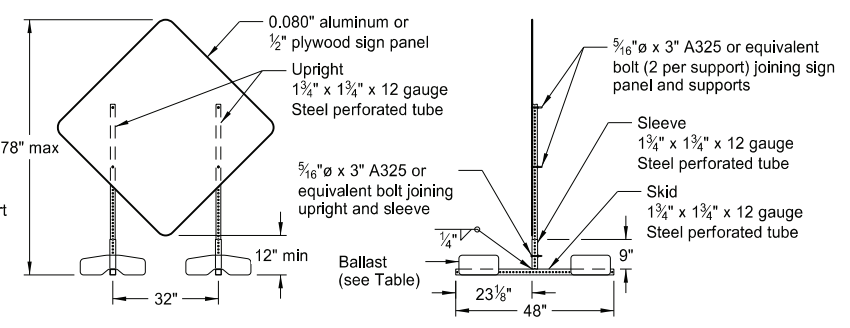

PORTABLE SIGN SUPPORT
LOW-MOUNTING HEIGHT

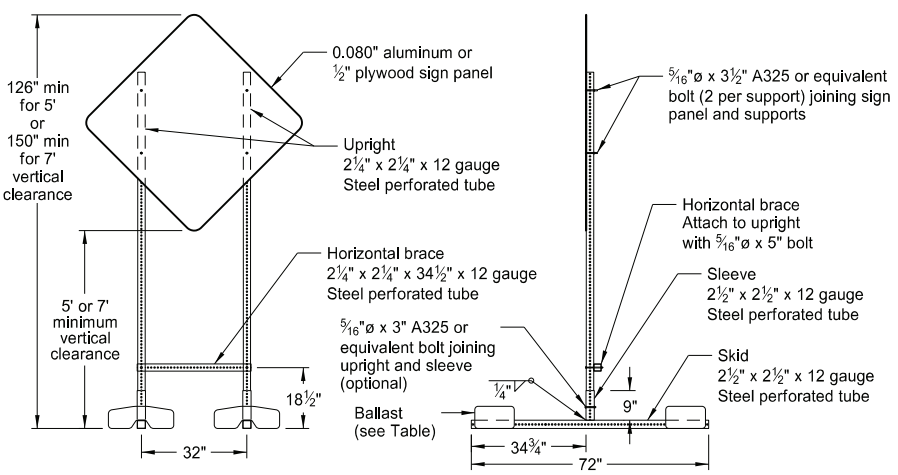

PORTABLE SIGN SUPPORT
HIGH-MOUNTING HEIGHT

NOTES:

- Sign Supports: Galvanize or paint supports. Minimum post sizes are 2.5 lb/ft u-channel or 2" x 2" x 12 gauge steel perforated tube, except where noted. When installing signs on u-channel, minimum post size for assemblies containing a secondary sign is 3.0 lb/ft. Post sizes based on a wind speed of 55 MPH.

Place signs over 50 square feet on 2 1/2" x 2 1/2" perforated tube supports as a minimum.

Do not attach guy wires to sign supports. Attach wind beams behind sign panels when used with u-posts.
- Sign Panels: Provide sign panels made of 0.100" aluminum, 1/2" plywood, or other approved material, except where noted. Punch all holes round for 3/8" bolts.
- Alternate Messages: Install and remove alternate message signs on reflectorized plate (without borders) as required. (i.e. "Left" and "Right" message on lane closure sign)
- Route Marker Auxiliary Signs: Provide route marker auxiliary signs, such as the cardinal direction and directional arrows, with a background and legend that match the route marker they are used with:

Interstate - white legend on blue background
Interstate Business Loop - white legend on green background
US and State - black legend on white background
County - yellow legend on blue background

- Vertical Clearance: Install signs with a vertical clearance of 5'-0" (see TYPICAL SECTION.) In areas where parking or pedestrian movements are likely or the view of the sign may be obstructed, install signs with a vertical clearance of 7'-0" from the top of the curb or from the near edge of the driving lane in absence of a curb.

The vertical clearance to secondary signs is 1'-0" less than the vertical clearance stated above.

Provide a minimum clearance of 7'-0" from the ground at the post for signs with an area exceeding 50 square feet.

- Portable Signs: Provide portable signs that meet the vertical clearance stated above when it is necessary to place signs within the pavement surface.

Use of low-mounting height (minimum 12" vertical clearance) portable signs for 5 days or less, is allowed as long as the view of the sign is not obstructed. Time delays caused by unforeseen circumstances, such as equipment breakdown, rain, subgrade failures, etc., will not accrue towards the 5 day period. Use of R9-8 through R9-11a series, W1-6 through W1-8 series, M4-10, and E5-1 is allowed for longer than 5 days.

Restrict signs mounted on portable sign supports shown in the LOW-MOUNTING HEIGHT and HIGH-MOUNTING HEIGHT details to a maximum surface area of 16 square feet.

MINIMUM BALLAST
(For each side of sign support base)

Sign Panel Mounting Height (ft)	Number of 25 lb sandbags for 4' x 4' sign panel
1'	6
5'	8
7'	10

Note: The number of sandbags are based on a wind speed of 55 MPH. Place sandbags at or near the ends of sklds.

NORTH DAKOTA DEPARTMENT OF TRANSPORTATION	
10-4-13	
REVISIONS	
DATE	CHANGE
11-14-13	Revised Note 6
9-27-17	Updated to active voice
11-01-19	Revised 60"x24" sign detail
8-01-24	Electronic Stamp/Signature



08/01/24

CONSTRUCTION TRUCK AND TEMPORARY DETOUR LAYOUTS

D-704-22

KEY

- Type III barricade
- Sign
- Work area
- Flagger

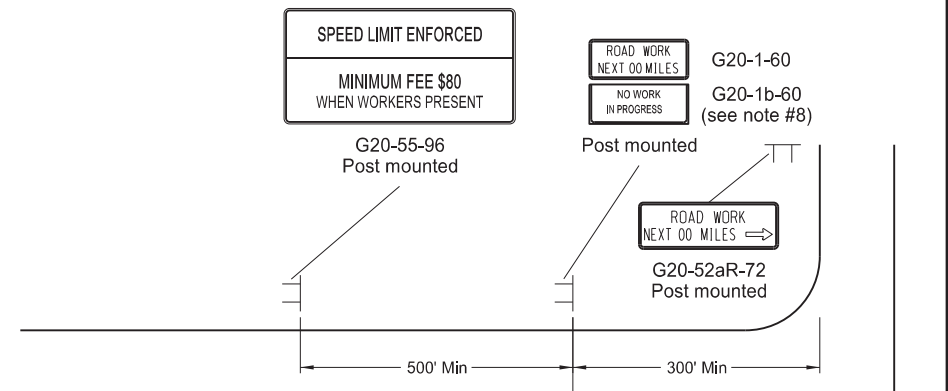
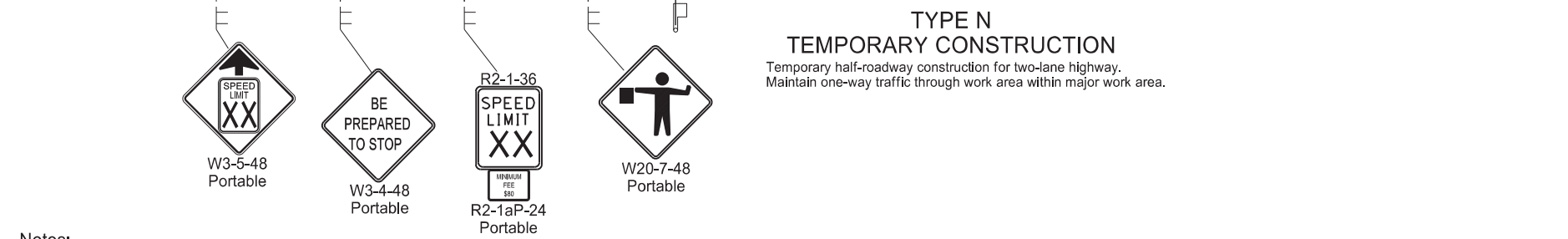
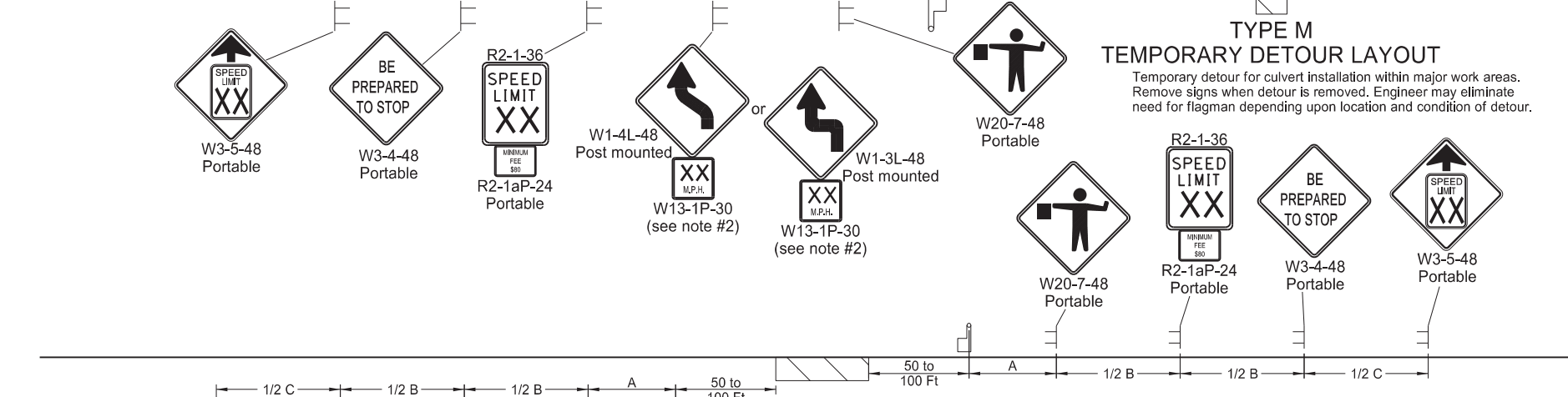
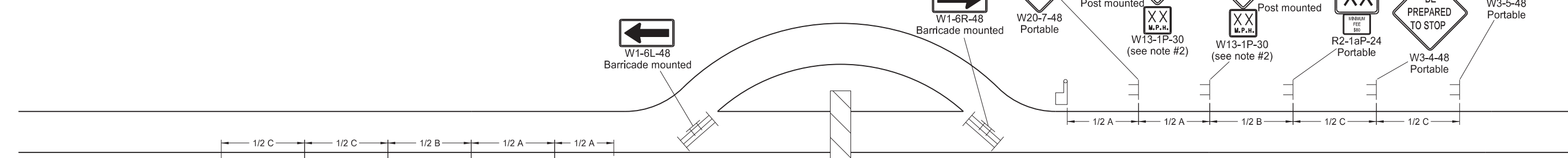
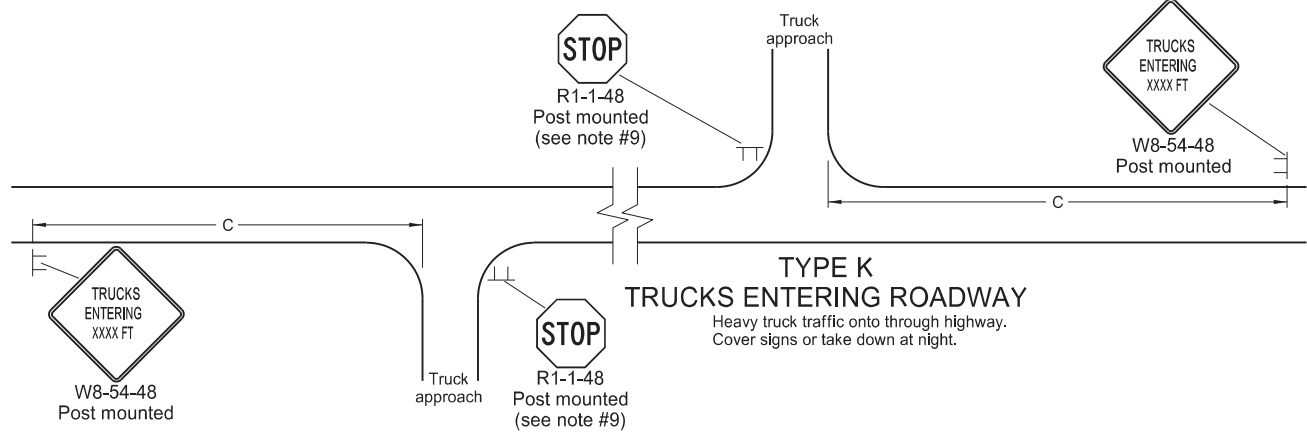

- Notes:**
- Place barricades on a moveable assemblies and signs on portable assemblies when located on roadway.
 - Where necessary, safe speed to be determined by the Engineer.
 - Determine the reduced speed limit based on the in-place speed limit before construction. Where speed reductions exceed 30 mph, install a second speed limit sign with the desired speed reduction (not to exceed 30 mph.) Place the second speed limit sign at 1/2 B.
 - Install flags on warning signs in urban areas when signs are not portable. Mount 24 inch square flags perpendicular to the edges of the sign, and at such a distance above the edge that the flag does not touch the sign when limp.
 - Cover existing speed limit signs within a reduced speed zone.
 - Covered (when approved by engineer) or obliterated pavement marking measured as Obliteration of Pavement Marking.
 - As an option, use portable sign supports in lieu of post mounted signs in accordance with NDDOT Standard Drawing D-704-14.
 - Install sign G20-1b-60 when work is suspended for winter.
 - If existing stop sign is in place, a 48" stop sign is not required.
 - Sign G20-55-96 is not required if layout is part of other traffic control that contains this sign, or if work is less than 15 days.
 - Recommend using 40 mph speed limit in vicinity of workers, unless location and conditions dictate otherwise.

Road Type	Distance Between Signs Min. (ft)		
	A	B	C
Urban - Low Speed (30 mph or less)	150	150	150
Urban - Low Speed (over 30 to 40mph)	280	280	280
Urban - High Speed (over 40 mph to 50 mph)	360	360	360
Rural - High Speed (over 50 mph to 65 mph)	720	720	720
Urban Expressway and Freeway (55 mph to 60 mph)	850	1350	2200
Rural Expressway and Freeway (70 mph to 75 mph)	1000	1500	2640
Interstate/4-Lane Divided (Maintenance and Surveying)	750	1000	1500

NORTH DAKOTA DEPARTMENT OF TRANSPORTATION	
9-27-13	
REVISIONS	
DATE	CHANGE
08-17-17	Update notes & sign numbers
11-01-19	Revised sign numbers & note 7
12-09-21	Added Speed Limit Enforced and Dollars At Work signs
11-29-22	Removed Dollars At Work



11/29/22

SHOULDER CLOSURES AND BRIDGE PAINTING LAYOUTS

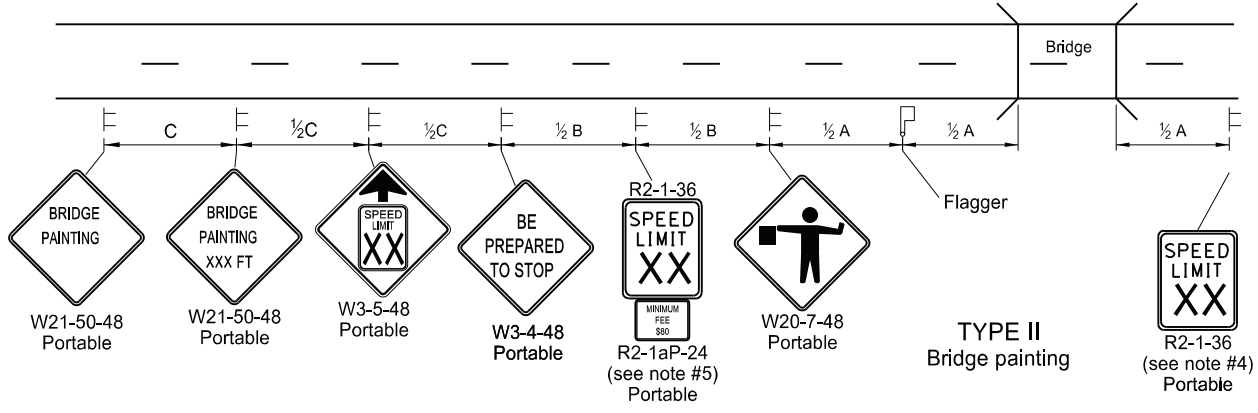
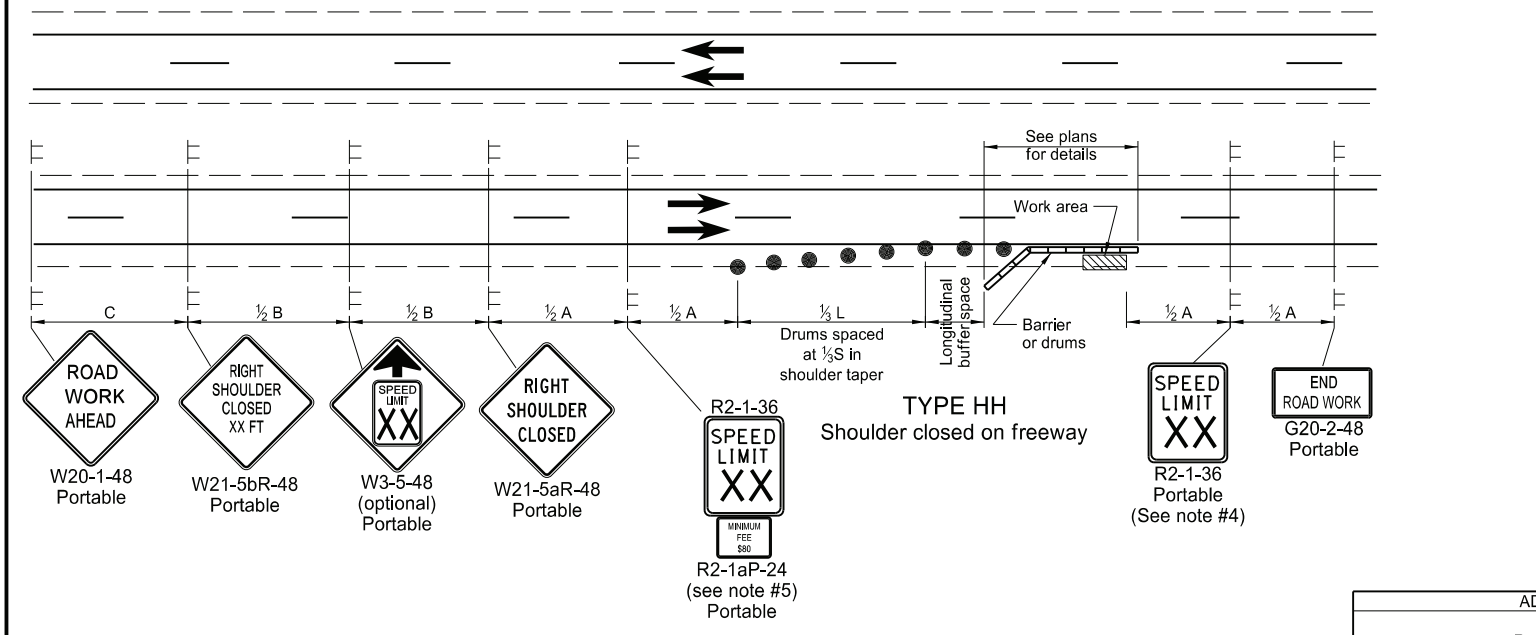
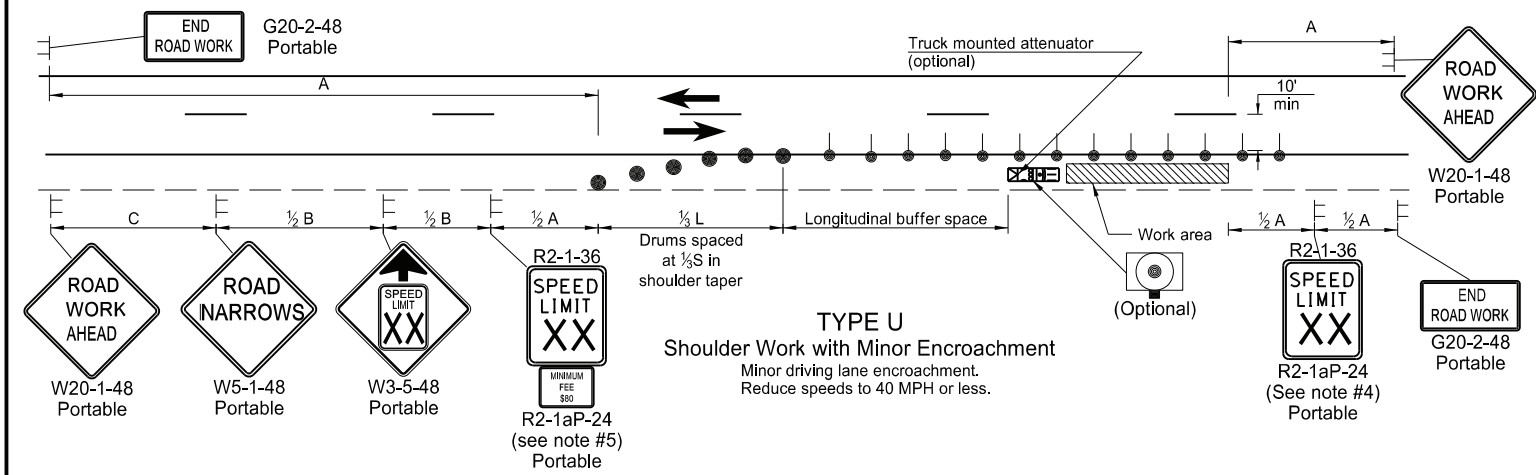
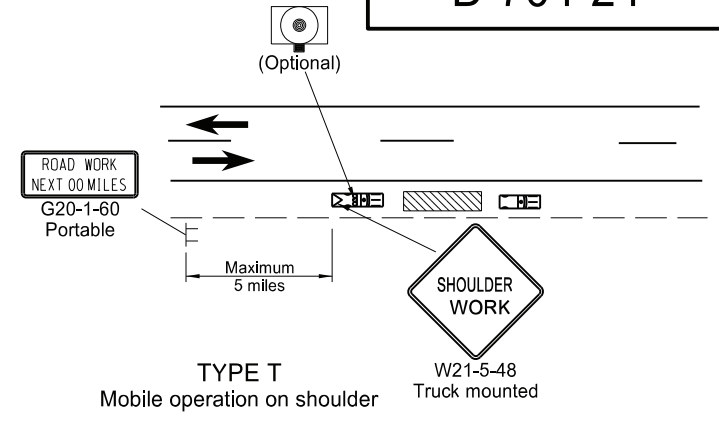
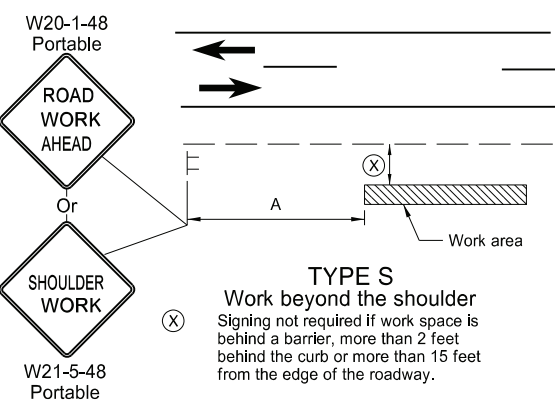
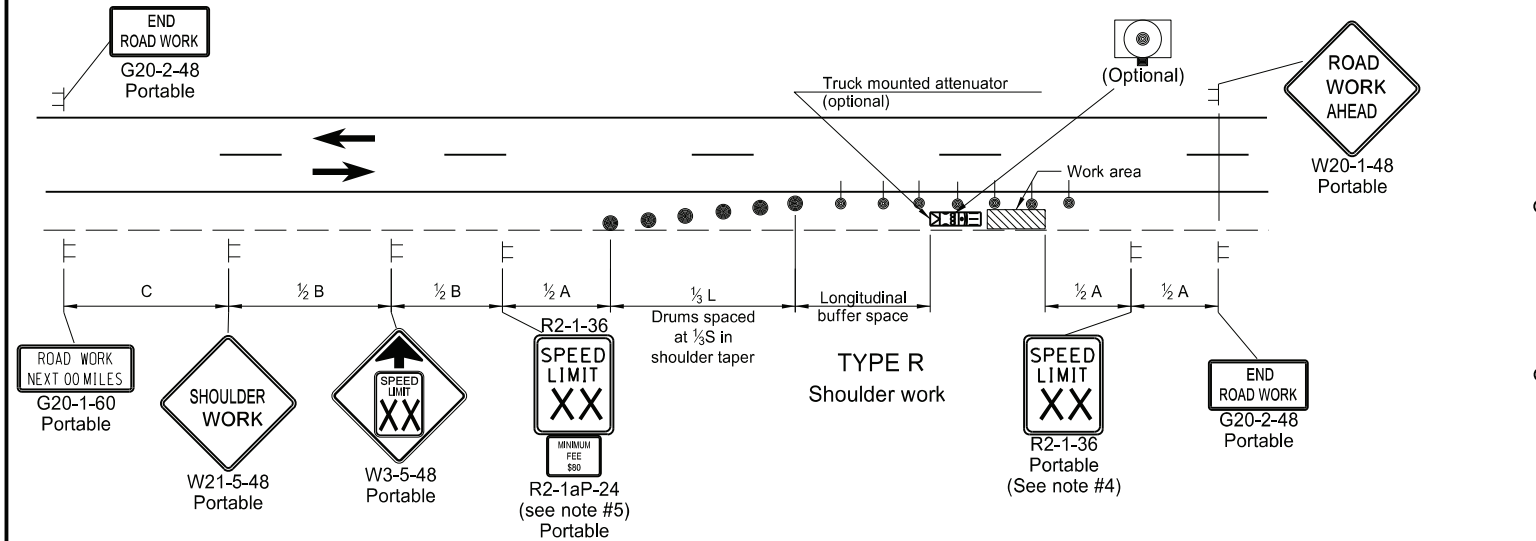

- Notes
- Variables
 - S = Numerical value of speed limit or 85th percentile.
 - W = The width of the taper in feet.
 - L = Minimum length of taper, $S \times W$ for freeways, expressways, and all other roads with speeds of 45 mph or greater, or $W \times S^2 / 60$ for urban, residential, and other streets with speeds of 40 mph or less.
 - Space delineator drums for tapering traffic at dimension "S". Space delineator drums or tubular markers for tangents at 2 times "S".
 - Sequencing Arrow Panels
 - Use Type A on roadways with slow moving traffic speeds and low volume (25 mph or less and 750 ADT or less).
 - Use Type B on roadways with moderate traffic speeds and volumes (40 mph or less and 5000 ADT or less).
 - Use Type C on roadways with high traffic speeds and volumes (over 40 mph or over 5000 ADT).
 - Re-establish speed limit. Determine exact speed limit in the field, dependent on location and conditions.
 - Determine the reduced speed limit based on the in-place speed limit before construction. Where speed reductions exceed 30 MPH, install a second speed limit sign with the desired speed reduction (not to exceed 30 mph.) Place the second speed limit sign at 1/2 B. Install flags on warning signs in urban areas when signs are not portable. Mount 24 inch square flags perpendicular to the edges of the sign, and at such a distance above the edge that the flag does not touch the sign when limp.
 - Cover existing speed limit signs within a reduced speed zone.
 - As an option, use portable sign supports in lieu of post mounted signs in accordance with NDDOT Standard Drawing D-704-14.
 - Recommend 40 mph speed limit in vicinity of workers, unless location and conditions dictate otherwise.

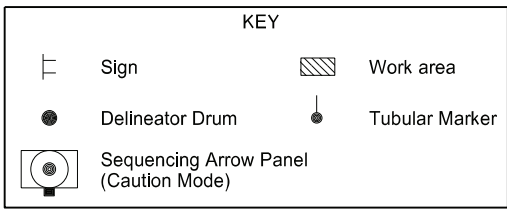

Road Type	Distance Between Signs Min. (ft)		
	A	B	C
Urban - Low Speed (30 mph or less)	150	150	150
Urban - Low Speed (over 30 to 40 mph)	280	280	280
Urban - High Speed (over 40 mph to 50 mph)	360	360	360
Rural - High Speed (over 50 mph to 65 mph)	720	720	720
Urban Expressway and Freeway (55 mph to 60 mph)	850	1350	2200
Rural Expressway and Freeway (70 mph to 75 mph)	1000	1500	2640
Interstate/4-Lane Divided (Maintenance and Surveying)	750	1000	1500

Longitudinal Buffer Space	
Speed (mph)	Length Min (feet)
20	115
25	155
30	200
35	250
40	305
45	360
50	425
55	495
60	570
65	645
70	730
75	820

NORTH DAKOTA DEPARTMENT OF TRANSPORTATION	
9-27-13	
REVISIONS	
DATE	CHANGE
8-17-17	Updated notes & revised signs
11-01-19	Revised drum spacing & signs nos.
8-01-24	Electronic Stamp/Signature

KIRK J. HOFF
REGISTERED
PROFESSIONAL
PE-4683
ENGINEER
NORTH DAKOTA
08/01/24

Two-Lane Roadway Portable Rumble Strips

KEY

- Work area
- Flagger
- Sign

S = Numerical value of speed limit or 85th percentile.

Road Type	Distance Between Signs Min. (ft)		
	A	B	C
Urban - High Speed (over 45 mph to 50 mph)	360	360	360
Rural - High Speed (over 50 mph to 65 mph)	720	720	720

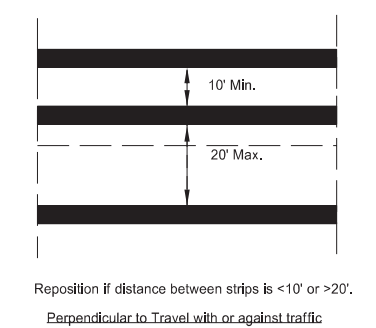
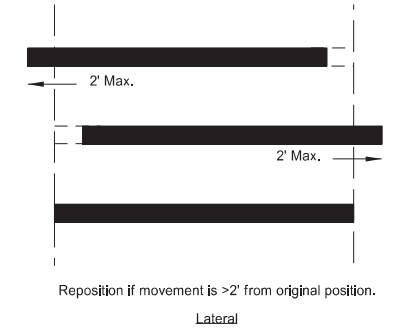
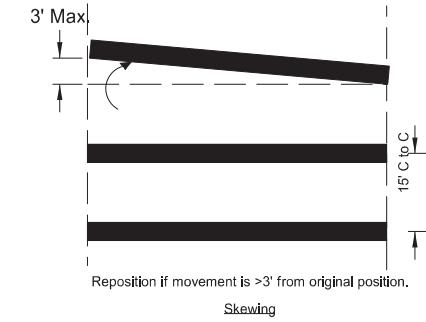
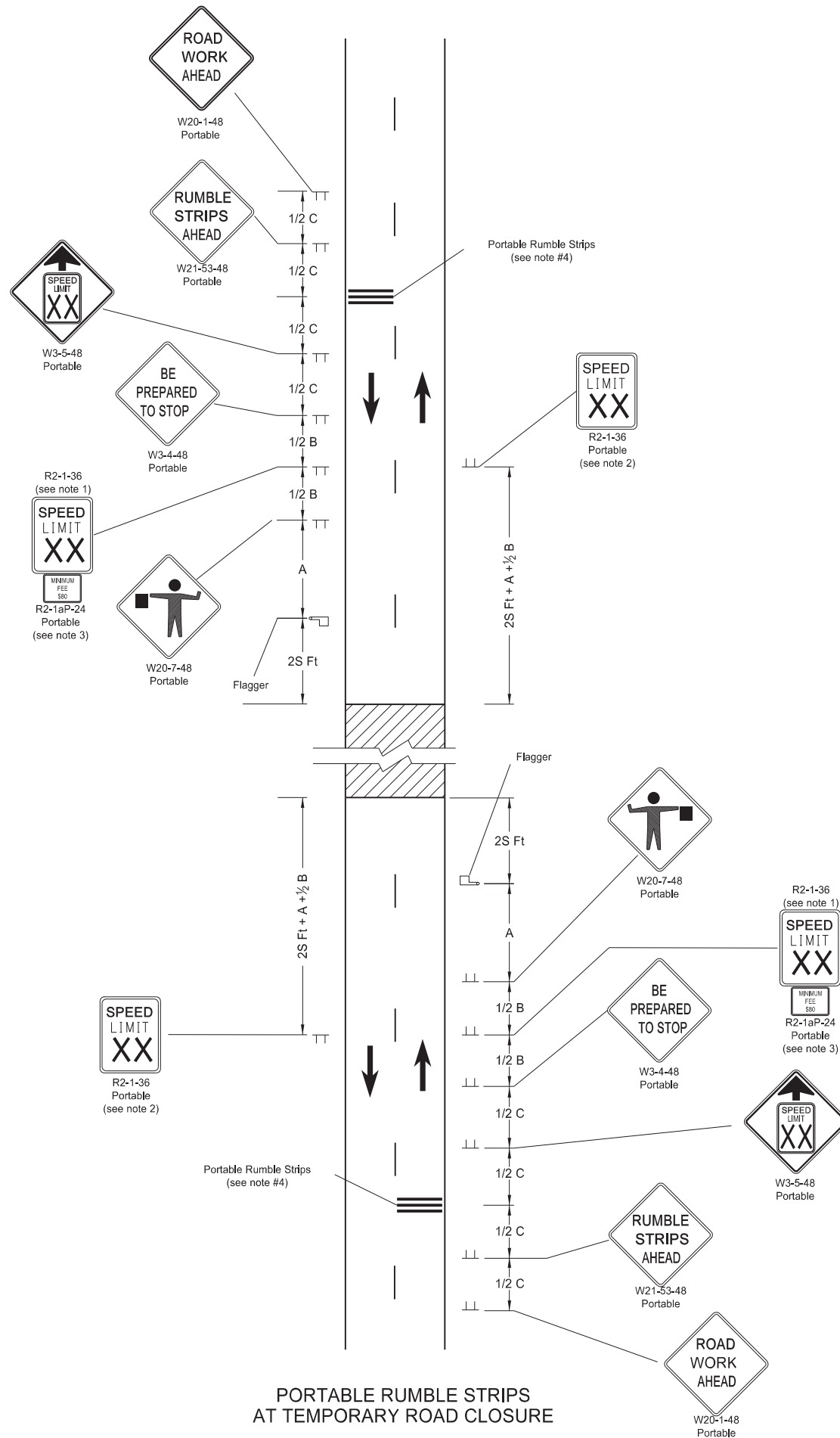

PORTABLE RUMBLE STRIPS ARRAY TYPES OF MOVEMENT AND MAXIMUM ALLOWANCES

- Notes:
- Determine speed in the field based on location and conditions.
 - Re-establish the speed limit. Determine the exact speed limit in the field, dependent on location and conditions.
 - Sign R2-1aP-24 is not required when pilot car operation is used.
 - Do not use rumble strips on a non paved surface or in a pre-construction speed zone of 45 mph or less.

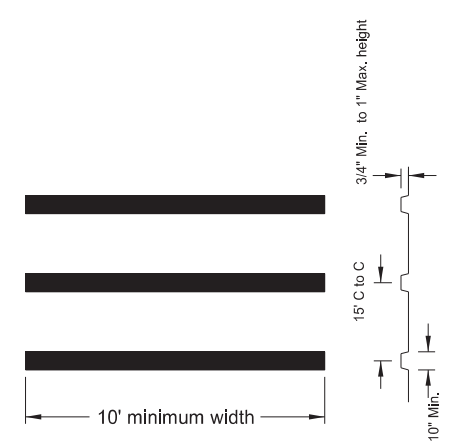

PORTABLE RUMBLE STRIPS ARRAY DETAIL

PORTABLE RUMBLE STRIPS AT TEMPORARY ROAD CLOSURE

NORTH DAKOTA DEPARTMENT OF TRANSPORTATION		
02-22-22 REVISIONS		
DATE	CHANGE	<p>03/07/23 Use changed to min 45 mph.</p>
03/07/23		

03/07/23

PORTABLE SIGN SUPPORT ASSEMBLY

D-704-50

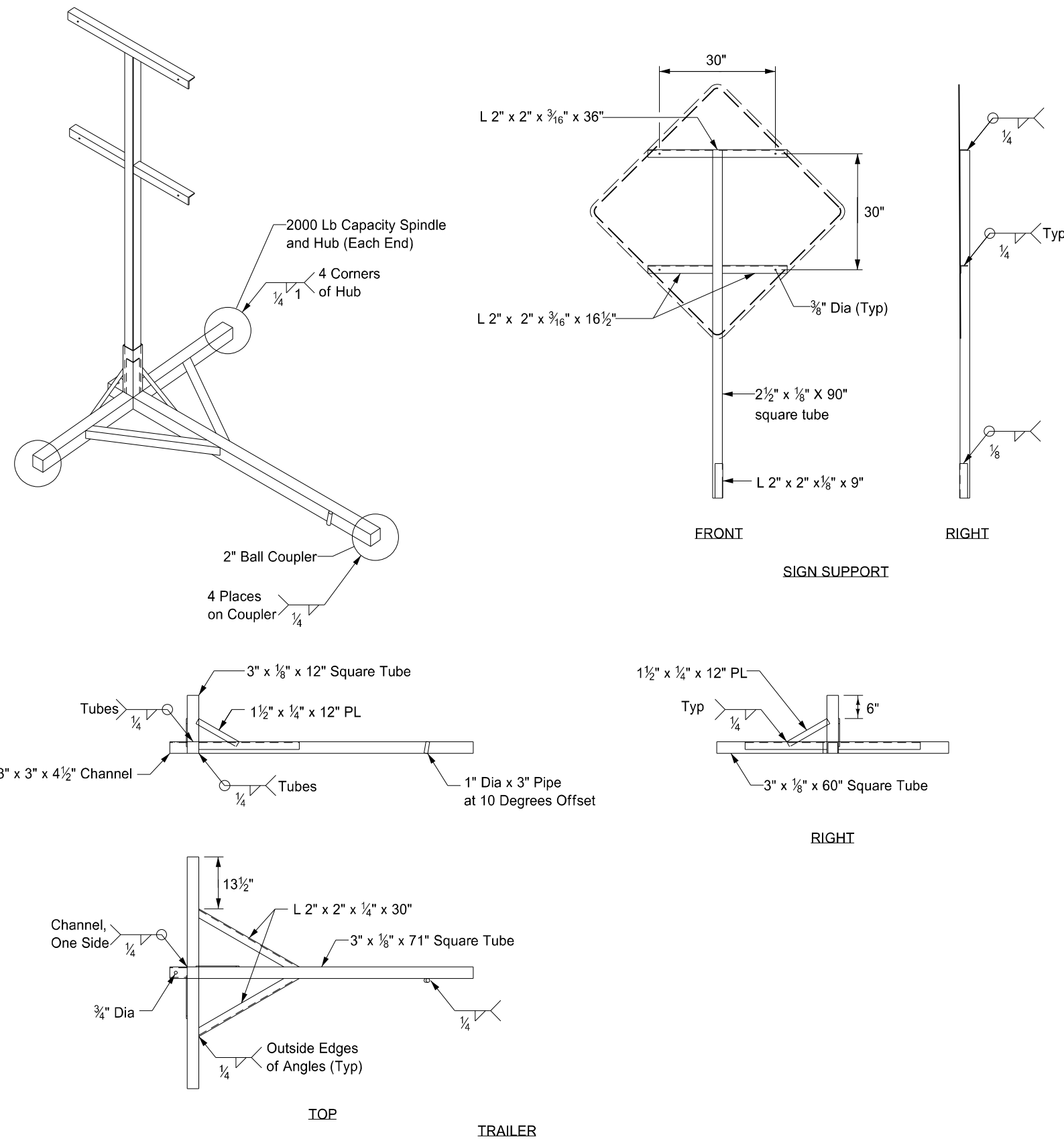

Notes:

- ① Maximum 250 pound weight of assembly.
- ② Use a 14" wheel and tire.
- ③ Use no automotive and equipment axle assemblies for trailer-mounted sign supports.
- ④ Other NCHRP 350 or MASH crash tested assemblies are acceptable.

NORTH DAKOTA DEPARTMENT OF TRANSPORTATION	
11-23-10	
REVISIONS	
DATE	CHANGE
12/02/2020	Updated Note to active voice.

KIRK J. HOFF
REGISTERED
Kirk J Hoff
PROFESSIONAL
PE-4683
ENGINEER
NORTH DAKOTA
12 02 2020

EROSION AND SILTATION CONTROLS
MEDIAN OR DITCH INLET PROTECTION

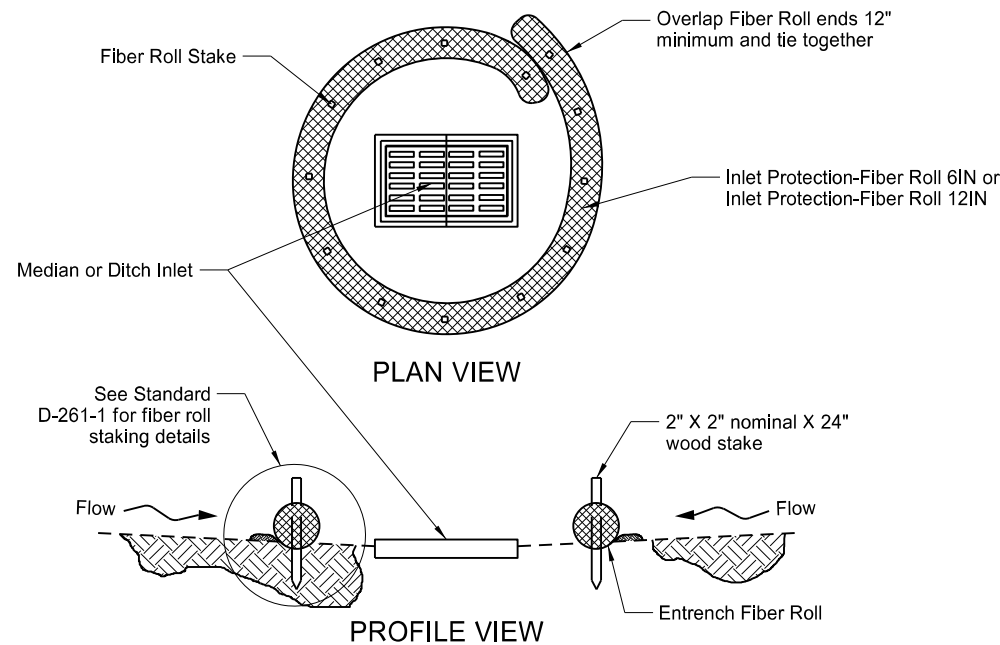

FIBER ROLL PROTECTION (MEDIAN OR DITCH INLET)

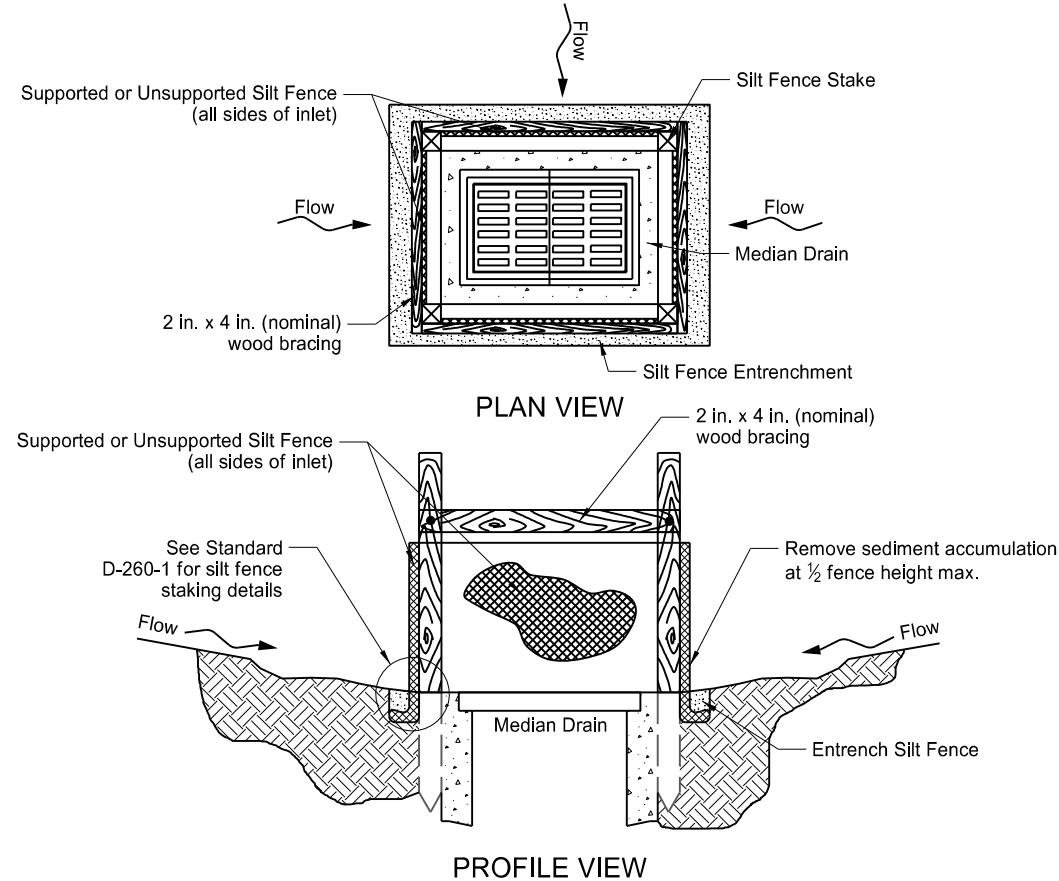

SILT FENCE PROTECTION (MEDIAN OR DITCH INLET)

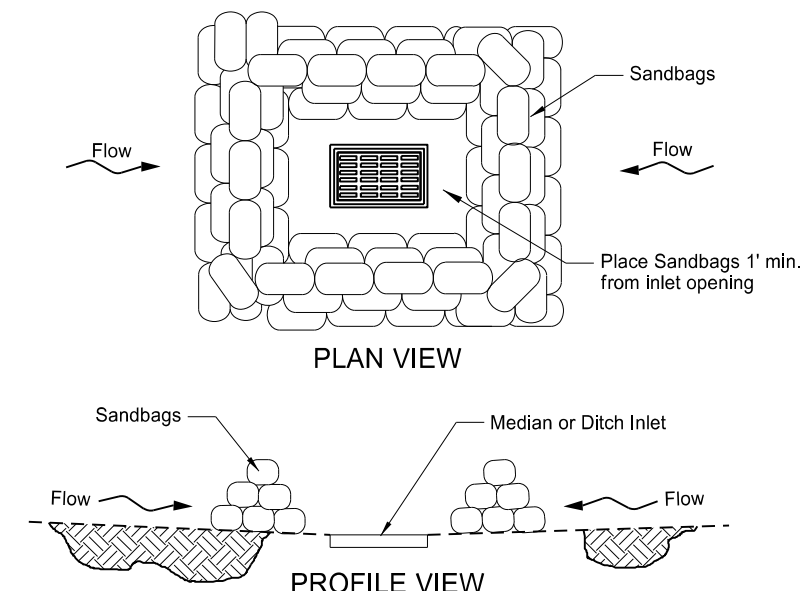

SANDBAG PROTECTION (LOW POINT)

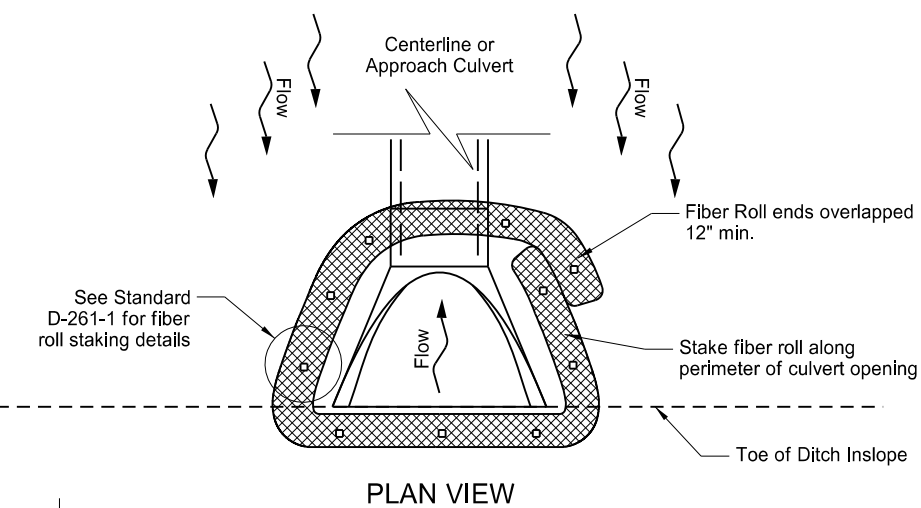

FIBER ROLL PROTECTION (INLET OF CULVERT)

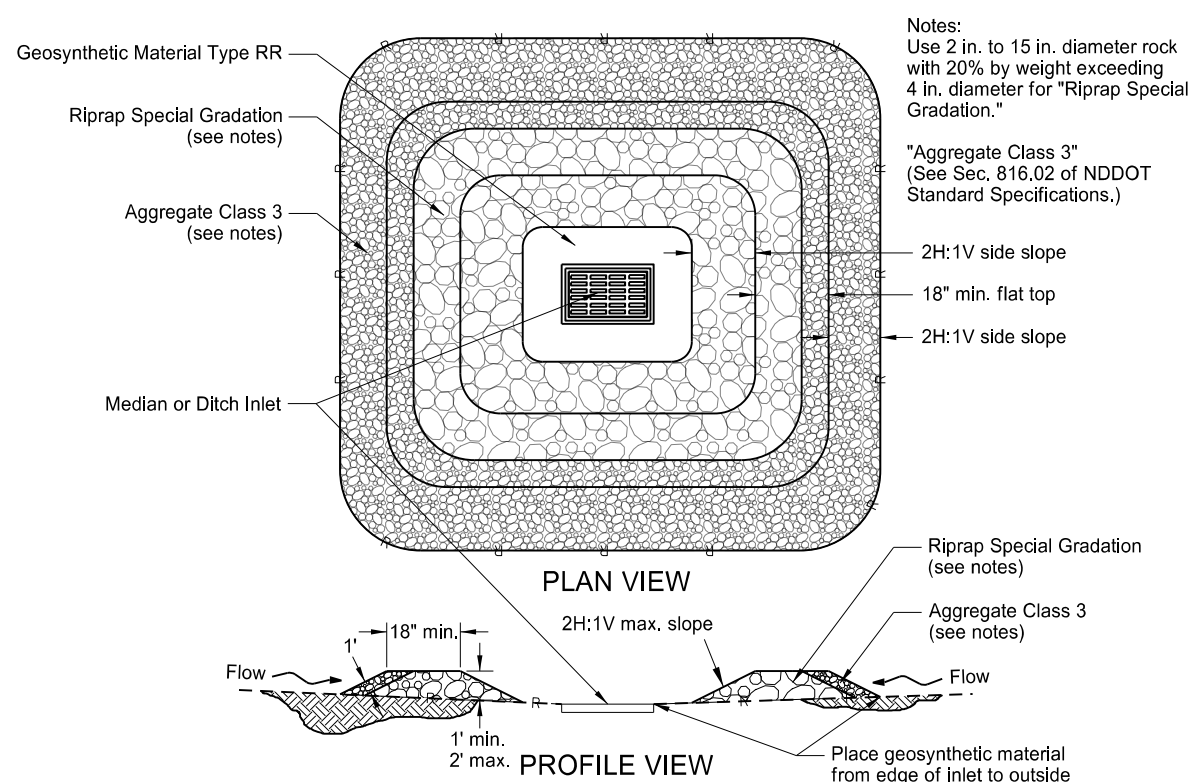

GRAVEL INLET PROTECTION (MEDIAN OR DITCH INLET)

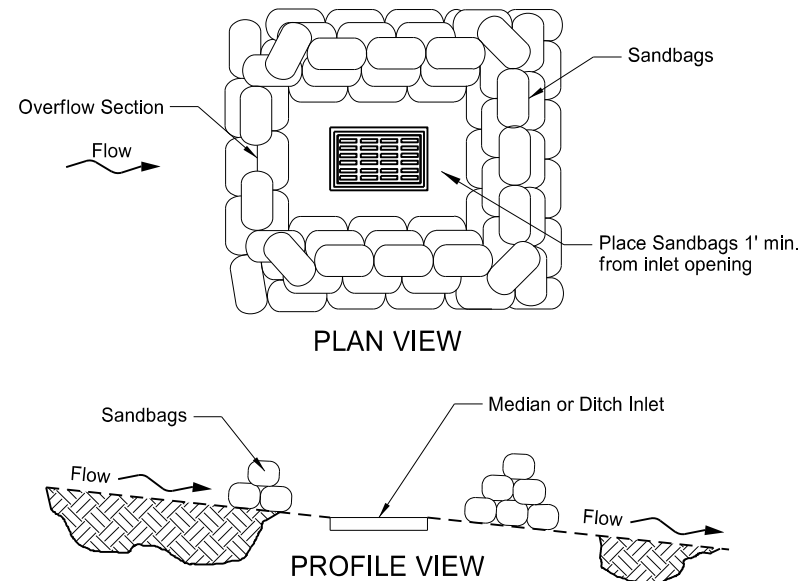

SANDBAG PROTECTION (ON SLOPE)

Notes:
 Use 2 in. to 15 in. diameter rock with 20% by weight exceeding 4 in. diameter for "Riprap Special Gradation."
 "Aggregate Class 3"
 (See Sec. 816.02 of NDDOT Standard Specifications.)

NORTH DAKOTA DEPARTMENT OF TRANSPORTATION	
10-03-13	
REVISIONS	
DATE	CHANGE
06-26-14	Updated reference to standard drawing number for fiber roll staking details.
10-01-14	Updated reference to standard drawing number for silt fence.
10-17-17	Updated to active voice.
08-27-19	New Design Engineer PE Stamp.

This document was originally issued and sealed by
 Kirk J Hoff,
 Registration Number
 PE- 4683,
 on 8-27-19 and the original document is stored at the North Dakota Department of Transportation

REINFORCED CONCRETE PIPE CULVERTS AND END SECTIONS
(Round Pipe)

FLARED END SECTION						
TERMINAL DIMENSIONS						
DIA	A	B	C	D	E	U
12	0'-4"	2'-0"	4'-0 ⁷ / ₈ "	6'-0 ⁷ / ₈ "	2'-0"	2"
15	0'-6"	2'-3"	3'-10"	6'-1"	2'-6"	2 ¹ / ₄ "
18	0'-9"	2'-3"	3'-10"	6'-1"	3'-0"	2 ¹ / ₂ "
21	0'-9"	3'-0"	3'-1"	6'-1"	3'-6"	2 ¹ / ₂ "
24	0'-9 ¹ / ₂ "	3'-7 ¹ / ₂ "	2'-6"	6'-1 ¹ / ₂ "	4'-0"	3"
27	0'-10 ¹ / ₂ "	4'-0"	2'-1 ¹ / ₂ "	6'-1 ¹ / ₂ "	4'-6"	3 ¹ / ₂ "
30	1'-0"	4'-6"	1'-7 ¹ / ₄ "	6'-1 ³ / ₄ "	5'-0"	3 ¹ / ₂ "
36	1'-3"	5'-3"	2'-9"	8'-0"	6'-0"	4"
42	1'-9"	5'-3"	2'-9"	8'-0"	6'-6"	4 ¹ / ₂ "
48	2'-0"	6'-0"	2'-0"	8'-0"	7'-0"	5"
54	2'-3"	5'-5"	2'-9 ¹ / ₄ "	8'-2 ¹ / ₄ "	7'-6"	5 ¹ / ₂ "
60	2'-11"	5'-0"	3'-3"	8'-3"	8'-0"	5"
66	2'-6"	6'-0"	2'-3"	8'-3"	8'-6"	5 ¹ / ₂ "
72	3'-0"	6'-6"	1'-9"	8'-3"	9'-0"	6"
78	3'-0"	7'-6"	1'-9"	9'-3"	9'-6"	6 ¹ / ₂ "
84	3'-0"	7'-6 ¹ / ₂ "	1'-9"	9'-3 ¹ / ₂ "	10'-0"	6 ¹ / ₂ "
90	3'-5"	7'-3 ¹ / ₂ "	2'-0"	9'-3 ¹ / ₂ "	11'-0"	6 ¹ / ₂ "

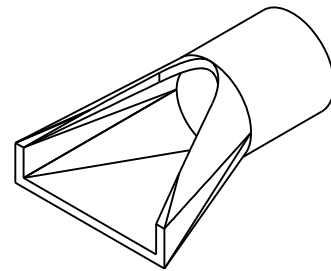

PERSPECTIVE

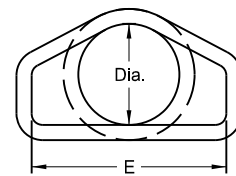

END VIEW

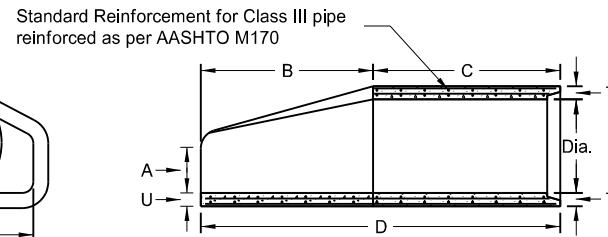

SIDE VIEW

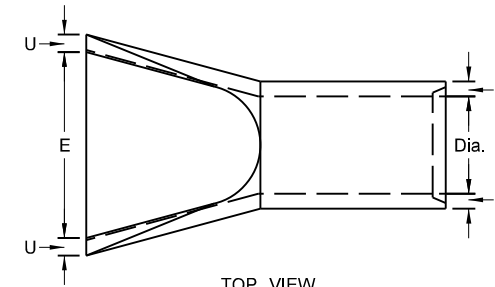

TOP VIEW

NOTES:

- All reinforcing steel shall meet AASHTO M170 requirements.
- All circular, longitudinal, and elliptical reinforcement shall be assembled and securely fastened in cage fashion so as to maintain reinforcement in exact shape and correct positions within the forms.
- Laying length of pipe: 12" to 66" (incl.) = not less than 4 feet
66" to 108" (incl.) = not less than 6 feet
- Joints shall be sealed with rubber gaskets or with sealer approved by the engineer whenever pipe are specified for storm drain or sanitary sewers.
- For Class IV and Class V reinforced concrete pipe and end section sizes which do not have reinforcement specified by AASHTO M170, shop drawings and design calculations shall be prepared and sealed by a Professional Engineer and submitted for the Engineer's review.

REINFORCED CONCRETE PIPE - FLARED END SECTION
Reinforcement to be equivalent to Class III RCP

TRAVERSABLE END SECTION						
DIA	B	C	D	E	R	S
15"	4'	9"	4'-9"	1'-7 ¹ / ₂ "	3"	6
18"	5'-9"	9"	6'-6"	1'-11"	3"	6
24"	6'	1'	7'	2'-6"	3"	4
30"	7'-6"	1'	8'-6"	3'-1"	3 ¹ / ₂ "	4
36"	7'-3"	15"	8'-6"	3'-8"	3"	4

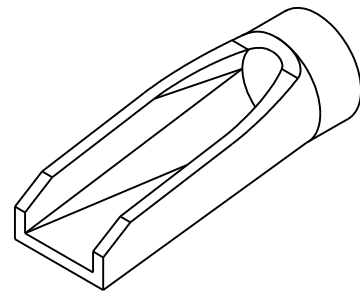

PERSPECTIVE

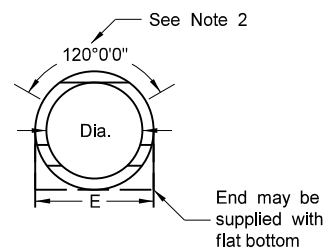

END VIEW

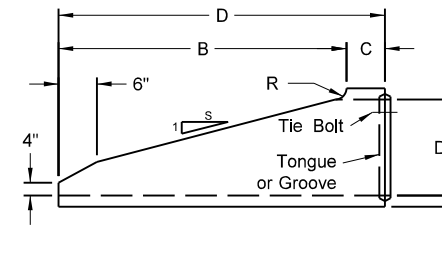

SIDE VIEW

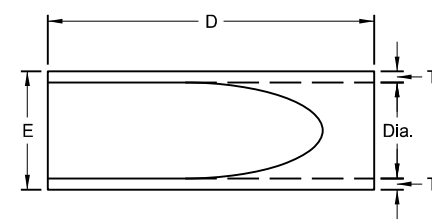

TOP VIEW

NOTES (Traversable End Section):

- Manufactured in accordance with applicable portions of ASTM C76/AASHTO M170.
- Reinforcement per Class III RCP with double reinforcement in the upper 120° of the full barrel portion.

REINFORCED CONCRETE PIPE - TRAVERSABLE END SECTION
Reinforcement to be equivalent to Class III RCP

All Classifications of Round Concrete Pipe						
Internal Dia. of pipe in Inches	Cross-Sectional Water Area	Weight per Lin. Foot of pipe Std. Wall	Joint J Groove End Min./Max.	Joint K Tongue End Min.	Minimum Wall Thickness (T)	
Dia	Sq. ft.	Lbs.	In.	In.	In.	
12	0.79	92	1 ¹ / ₈ -2 ³ / ₈	3/4	2	
15	1.23	127	1 ³ / ₈ -2 ¹ / ₄	7/8	2 ¹ / ₄	
18	1.77	168	1 ⁷ / ₈ -2 ⁷ / ₈	1	2 ¹ / ₂	
21	2.40	214	1 ⁷ / ₈ -3 ¹ / ₈	1 ¹ / ₈	2 ³ / ₄	
24	3.14	265	2 ³ / ₈ -3 ¹ / ₄	1 ¹ / ₂	3	
27	3.98	322	2 ³ / ₄ -4	1 ¹ / ₄	3 ¹ / ₄	
30	4.91	384	3 ¹ / ₄ -4 ¹ / ₄	1 ¹ / ₂	3 ¹ / ₂	
33	5.94	452	3 ¹ / ₄ -4 ¹ / ₄	1 ¹ / ₂	3 ³ / ₄	
36	7.07	524	3 ¹ / ₄ -4 ¹ / ₄	1 ¹ / ₂	4	
42	9.62	685	3 ³ / ₄ -4 ³ / ₄	1 ³ / ₄	4 ¹ / ₂	
48	12.57	885	3 ³ / ₄ -4 ³ / ₄	1 ³ / ₄	5	
54	15.90	1070	4 ¹ / ₈ -5 ¹ / ₄	2	5 ¹ / ₂	
60	19.63	1296	4 ¹ / ₂ -5 ¹ / ₂	2 ¹ / ₄	6	
66	23.76	1542	5-6	2 ³ / ₈	6 ¹ / ₂	
72	28.27	1810	5 ⁵ / ₈ -6 ³ / ₄	2 ³ / ₈	7	
78	33.18	2098	6 ¹ / ₄ -7 ¹ / ₄	2 ³ / ₈	7 ¹ / ₂	
84	38.48	2410	5 ⁵ / ₈ -7 ³ / ₄	3 ³ / ₈	8	
90	44.18	2793	6 ³ / ₄ -8 ¹ / ₂	3 ³ / ₈	8 ¹ / ₂	
96	50.27	3092	7-8 ¹ / ₄	3 ¹ / ₂	9	
102	56.75	3466	7-8 ¹ / ₄	3 ¹ / ₂	9 ¹ / ₂	
108	63.62	3864	7 ¹ / ₄ -8 ¹ / ₂	3 ³ / ₄	10	

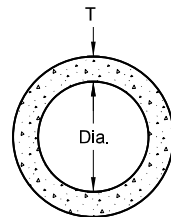

END VIEW

CIRCULAR PIPE

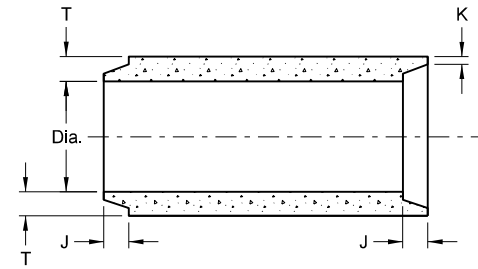

TONGUE & GROOVE JOINT

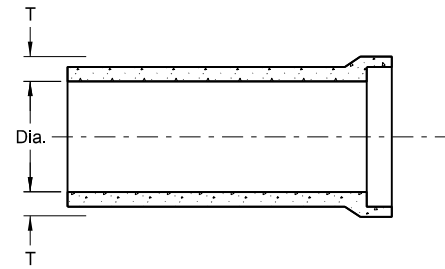

BELL & SPIGOT JOINT

JOINTS FOR REINFORCED CONCRETE PIPE

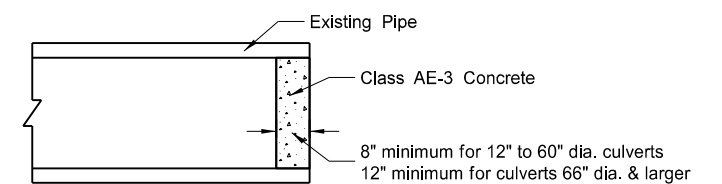

CONCRETE PIPE PLUG

SEE STANDARD DRAWING D-714-22 FOR DETAILS OF CONCRETE PIPE TIES (TIE BOLTS).

NORTH DAKOTA DEPARTMENT OF TRANSPORTATION	
05-12-14	
REVISIONS	
DATE	CHANGE
01-21-15	Revised Note 5
11-21-16	Revised End Section Dimensions
09-18-19	Updated Perspective View Details

This document was originally issued and sealed by
Jon Ketterling
Registration Number
PE-4684,
on **9/18/19** and the original document is stored at the
North Dakota Department
of Transportation

ROUND CORRUGATED STEEL PIPE CULVERTS AND END SECTIONS

D-714-4

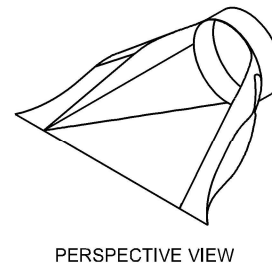
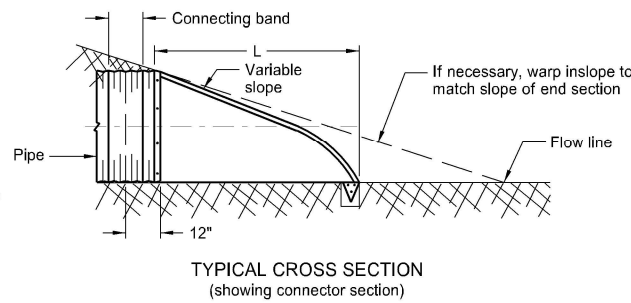
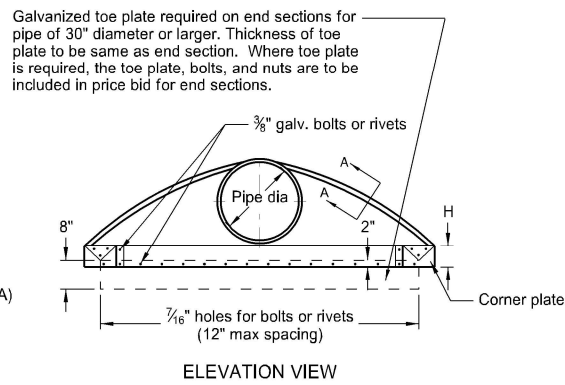
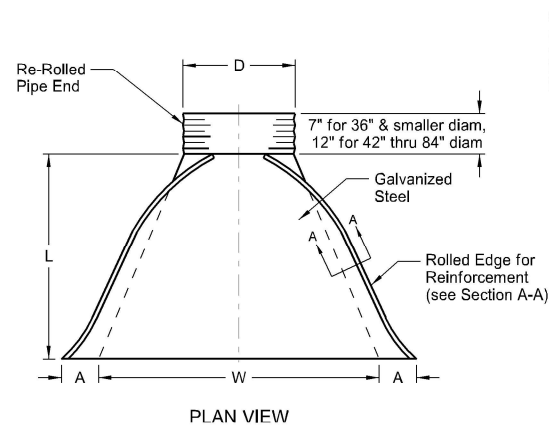

PIPE DIA.	GALVANIZED THICKNESS	END SECTION DIMENSIONS					APPROX. SLOPE RATE	BODY PIECE
		A	B	H	L	W		
15	0.064 - 0.079	7	8	6	26	30	2½:1	1
18	0.064 - 0.109	8	10	6	31	36	2½:1	1
24	0.064 - 0.109	10	13	6	41	48	2½:1	1
30	0.064 - 0.109	12	16	8	51	60	2½:1	1 or 2
36	0.064 - 0.109	14	19	9	60	72	2½:1	2
42	0.064 - 0.138	16	22	11	69	84	2½:1	2
48	0.064 - 0.168	18	27	12	78	90	2½:1	2
54	0.064 - 0.168	18	30	12	84	102	2:1	2
*60	0.064 - 0.168	18	33	12	87	114	1½:1	3
*66	0.064 - 0.168	18	36	12	87	120	1½:1	3
*72	0.064 - 0.168	18	39	12	87	126	1½:1	3
*78	0.064 - 0.168	18	42	12	87	132	1½:1	3
*84	0.064 - 0.168	18	45	12	87	138	1½:1	3

- * These sizes have 0.109" sides and 0.138" center panels.
 - * * Pipe diameter is equal to dimension "D" of end section.
- Manufacturers tolerances of above dimensions will be allowed.
- Splices to be the lap riveted type.

Multiple panel bodies shall have lap seams which are to be tightly joined with ¾" dia. galv. bolts or rivets. Nuts to be torqued to 25 foot-lbs ±.

NOTES:

- Pipes and connecting bands shall conform to applicable sections of NDDOT Standard Specifications and to AASHTO M-36.
- Top edge of all end sections to have rolled edges for reinforcement (see Section A-A). The reinforced edges are to be supplemented with 2" x 2" x ¼" galv. angle for 60" through 72" dia. and 2½" x 2½" x ¼" galv. angle for 78" and 84" dia.. Angles to be attached by galv. ¾" dia. bolts and nuts. Angles are to extend from pipe to the corner wing bend.
- Elongated pipes shall be factory preformed so that the vertical diameter shall be 5% greater and the horizontal diameter 5% less than a circular pipe.
- Coupling bands shall be two-piece for pipes larger than 36" as shown in Section C-C & D-D details. For pipes 36" and smaller, a one-piece band is acceptable.
- ½" x 8" bolts may be used as a substitute for the ½" x 6" bolts shown in the details.
- Coupling bands wider than 14" may be used if a minimum of four ½" bolts with maximum spacing of 5½" are used for the connection.
- Length of spot welds shall be minimum ½".

COUPLING BAND DIMENSIONS				
COUPLING TYPE	CORRUGATION PITCH x DEPTH	PIPE SIZE	COUPLING BAND LENGTH	MIN. BAND THICKNESS
Hat Band	2½" x ½"	12" - 48"	2¾"	.064"
		12" - 72"	12"	.052"
Annular Band	2½" x ½"	78" - 84"	12"	.079"
		48" - 120"	14"	.052"
Hugger Band	2½" x ½" Rerolled End	12" - 72"	10½"	.052"
		78" - 84"	10½"	.079"
	3" x 1" Rerolled End	48" - 120"	10½"	.052"
	5" x 1" Rerolled End	48" - 120"	12"	.064"

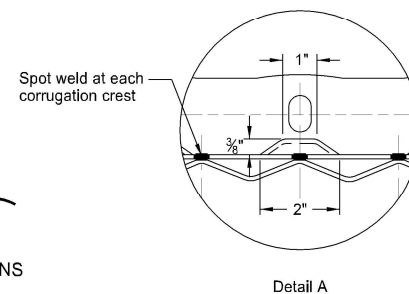
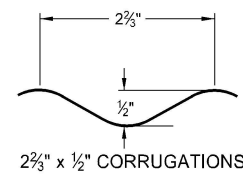
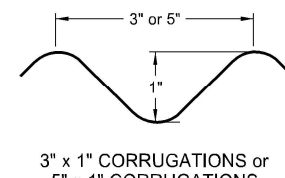
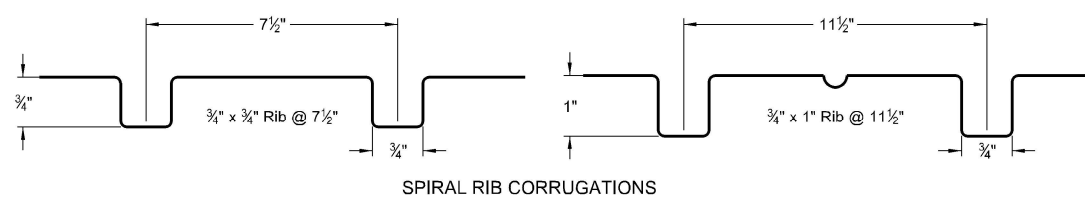
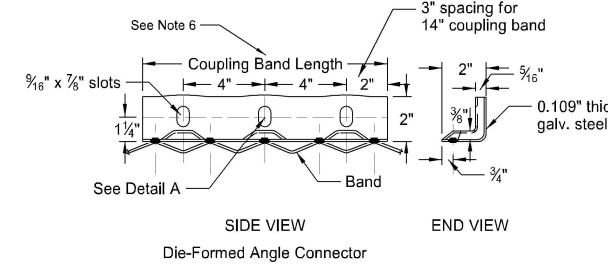
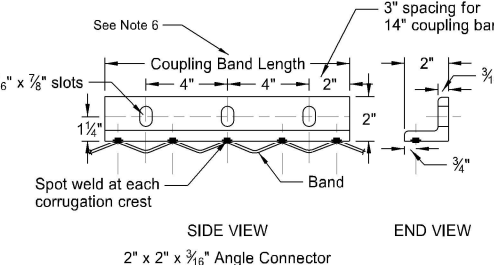
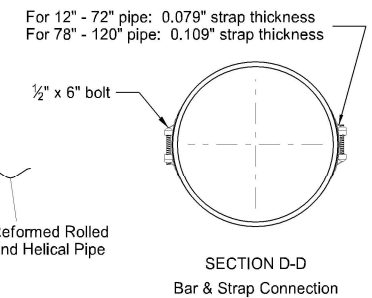
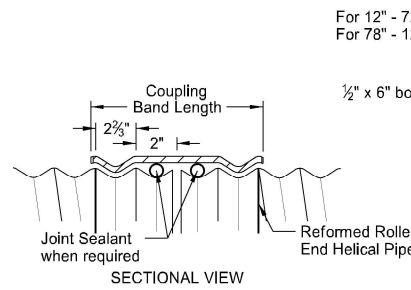
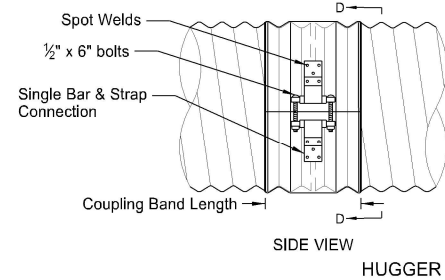
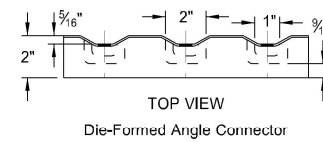
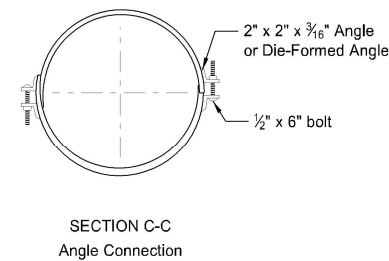
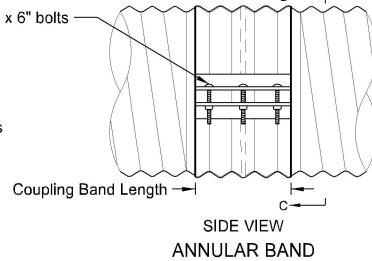
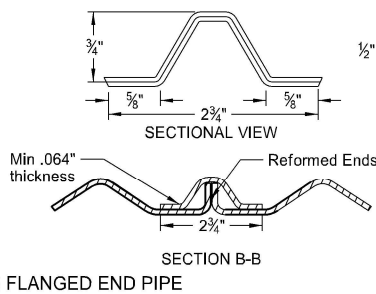
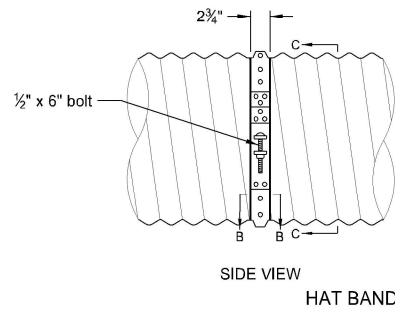
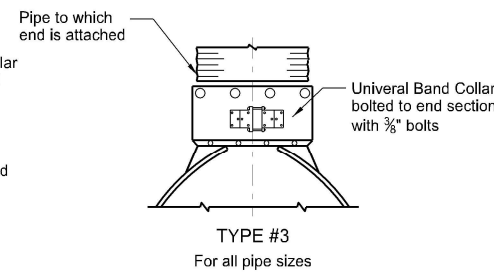
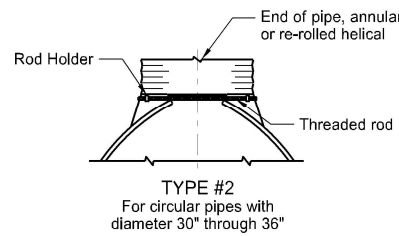
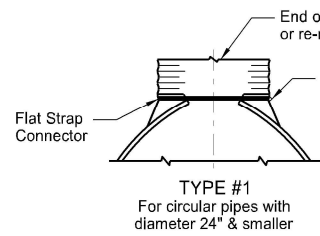
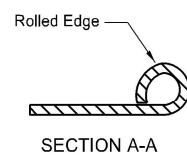

NORTH DAKOTA DEPARTMENT OF TRANSPORTATION	
08-16-13	
REVISIONS	
DATE	CHANGE
01-07-14	End Section Plan View
02-27-14	3" x 1" Corrugation Detail
09-18-19	Added Perspective View Detail
09-23-22	Galvanized Thickness Table



09/23/22

CONCRETE PIPE, CATTLE PASS, OR
PRECAST CONCRETE BOX CULVERT TIES

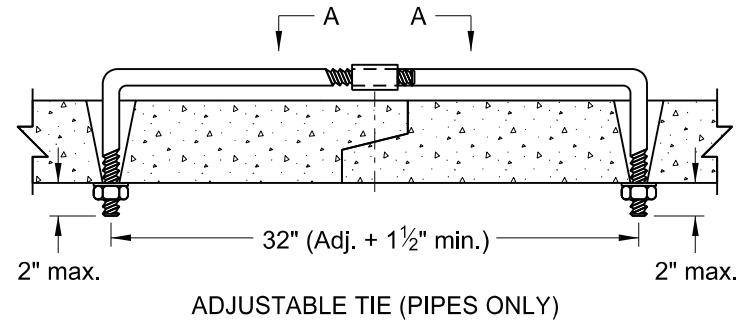
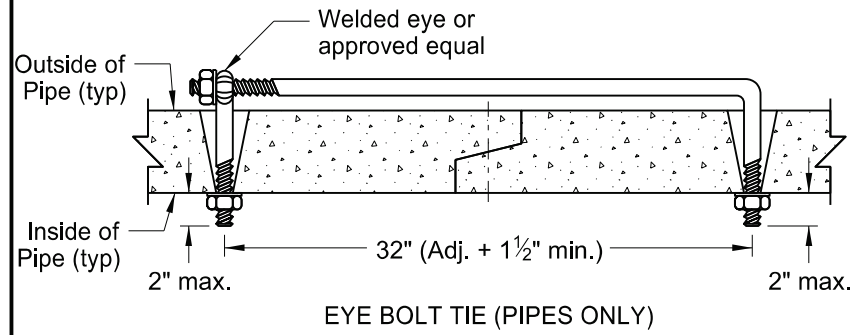

REQUIRED SIZE OF TIE BOLTS		
PIPE SIZE	THREAD Ø	XXS PIPE SLEEVE INNER Ø
18" - 24"	5/8"	3/4"
30" - 66"	3/4"	1"
72" - 120"	1"	1 1/4"
RCB/CATTLE PASS	1"	1 1/4"

NOTES:

- The pipe size listed is the inside diameter of round pipe or the equivalent diameter of pipe arch.
- Insert pipe ties from the inside of the pipes and grout into place for Cattle Pass and Jacked and Bored pipes. Jacked and bored pipes with a diameter of 24" or less do not require pipe ties.
- Nuts and washers are not required on Jacked and Bored pipes or pipes with a 24" diameter or less. Insert and grout tie bars into place where nuts and washers are not used.
- Do not use pipe ties to pull the pipe or RCB sections tight. The ties are only for holding sections together.
- Use only tie bolt assemblies that have been hot dip galvanized in accordance with ASTM A 153.
- Holes in pipes to accommodate tie bolts will be precast. Tapered holes are permitted. Use holes that have a diameter 1/4" larger than the diameter of the thread. In precast RCB's, use holes that contain cast-in bolt sleeves with an inside diameter of 1 1/4".
- Include the cost of precasting the required holes and furnishing and installing the tie bolts in the price bid for the appropriate conduit or RCB pay item.
- Tie all centerline and approach RCP culvert joints. Tie all joints including the end sections of all free ends of storm drain systems. Free ends are defined as any storm drain end which does not terminate at an inlet or manhole. Outfall culverts with end sections which drain adjacent ditches are examples of free ends.
- Place joint wrap prior to installing ties. Firmly secure the wrap around the full perimeter. For concrete pipes, use Type S2 geotextile fabric and overlap the joint by 12" in both directions. For box culverts, use a waterproof membrane that meets ASTM C990. Provide a membrane that is a minimum of 12" wide and center it at the joint. Provide a minimum overlap of 2.5" at the seams.
- Use tie bolts that conform to ASTM A 36. Use heavy hex nuts that conform to ASTM A 563. Use washers that conform to ASTM F 436, Type 1. Use welded pipe sleeves and cast-in bolt sleeves that conform to ASTM A 53, Grade B.
- Provide lock washers or burr threads of concrete box ties after installation and tightening to prevent nut rotation.
- Tie RCB's as noted in the plans.

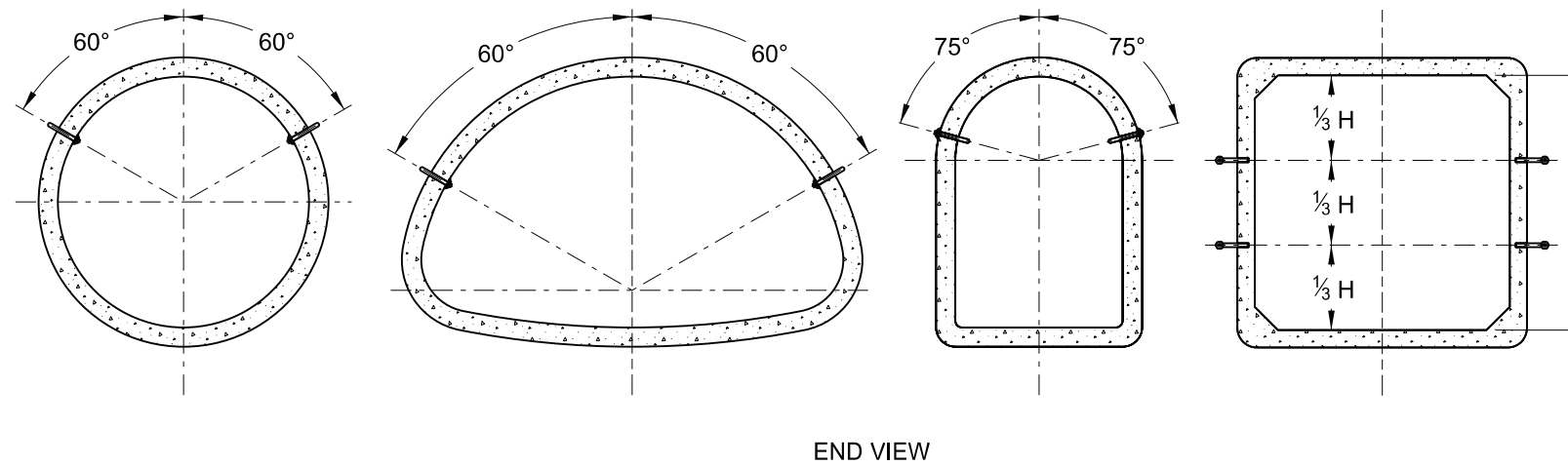
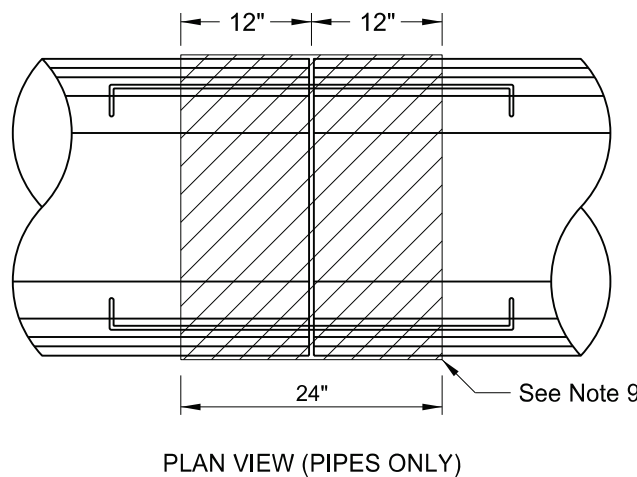
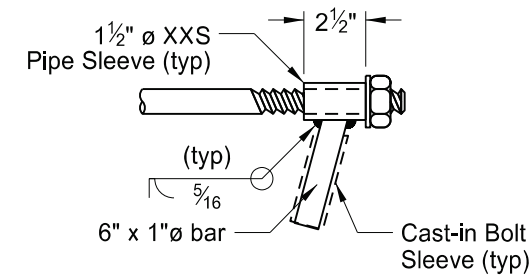
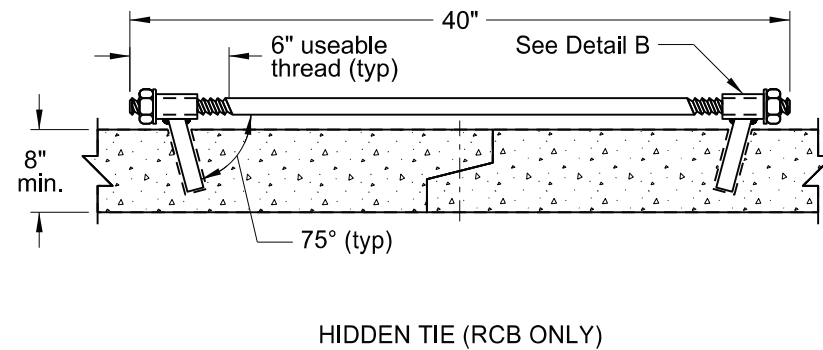
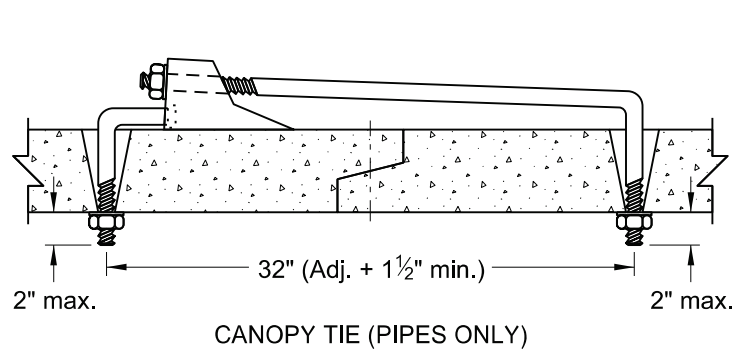
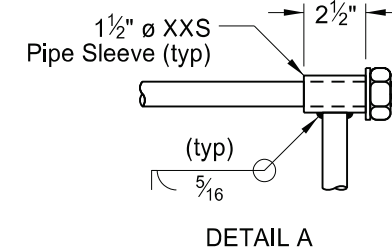
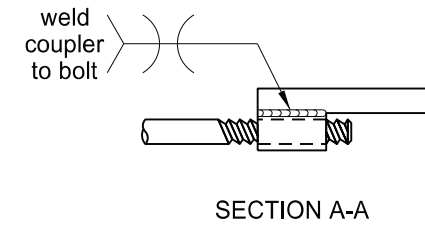
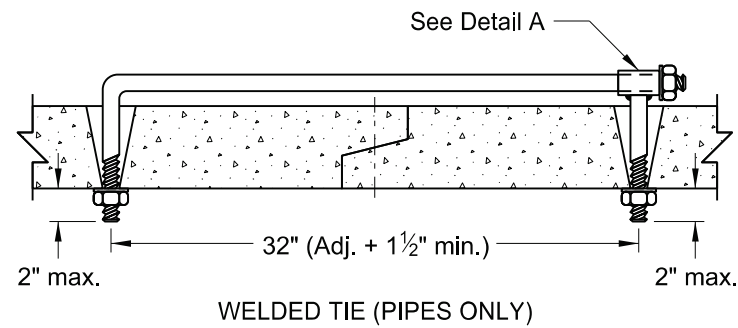
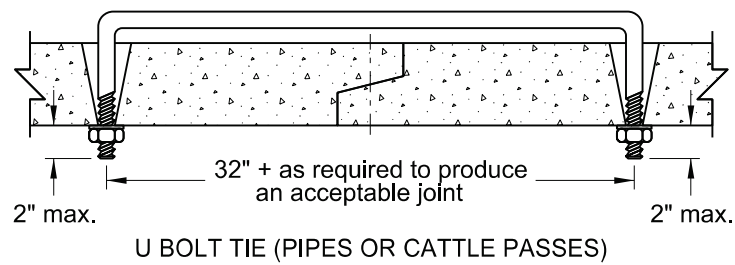

NORTH DAKOTA DEPARTMENT OF TRANSPORTATION	
3-18-14 REVISIONS	
DATE	CHANGE
7-21-15	Note 8
6-6-17	Notes 2-11 Table, Title, Labels
8-11-21	Notes 2-12 Table, Label
01-17-25	Notes 9-13 Table, Labels Section A-A, End View



SIDEWALK

D-750-2

NOTES:

- Curb ramp and detectable warning panel layouts for informational purposes only. See Standard Drawing D-750-3 for curb ramp and detectable warning panel details.
- Joint Spacing: Vary transverse contraction joint spacing from 4' to 6' to create approximate square panels.
Use longitudinal contraction joints when sidewalk width is 8' or greater, and space at half the sidewalk width.
Saw or groove contraction joints to a minimum depth of 1/3 the depth of the concrete.
When sidewalk is adjacent to curb & gutter, vary the sidewalk joint spacing to match curb & gutter joints.
Use isolation joints between separate concrete pours, or between old and new concrete.
- Include all costs for labor, equipment, and material necessary to construct contraction and isolation joints in the price bid for sidewalk concrete.
- Use 4" sidewalk concrete thickness unless otherwise specified.
- Use 4" base material thickness unless otherwise specified. Include all costs for labor and materials necessary to place the base material in the price bid for "Salvage Base Course" or "Aggregate Base Course CL 5."
Modify existing ground slope with landscaping as needed. If not possible, such as adjacent buildings, use a vertical curb as shown in the detail below. The Engineer will measure curb at the unit price bid for "Curb - Type I" per lineal foot.
- Sidewalk Width & Grade: Provide a continuous 4' min clear width pedestrian access route with max 2% concrete cross slope, excluding flares. The width of the curb cannot be counted as part of the pedestrian access route.
When clear width of pedestrian access routes is less than 5.0', provide passing spaces at a maximum of 200' with a minimum size of 5.0' by 5.0'.

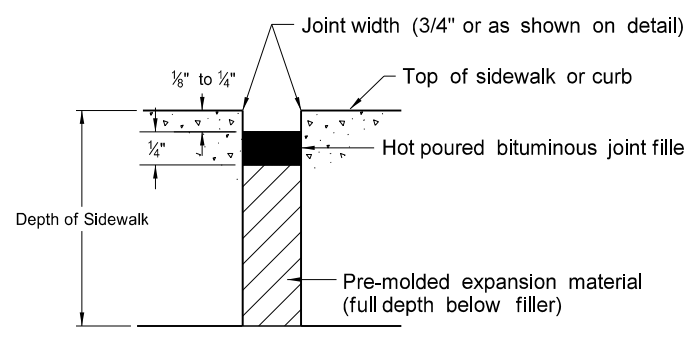
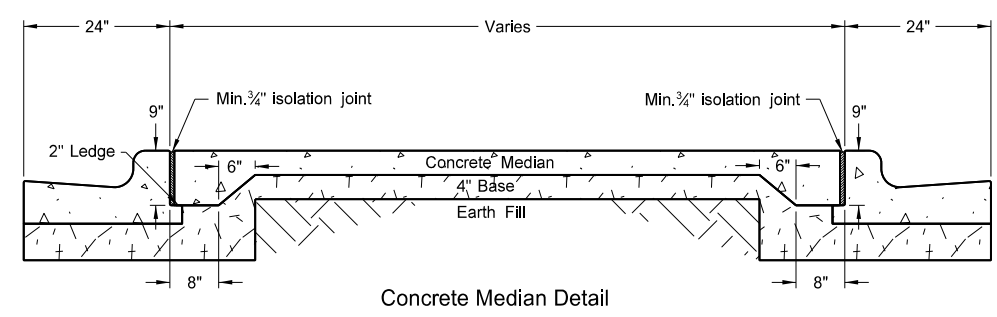
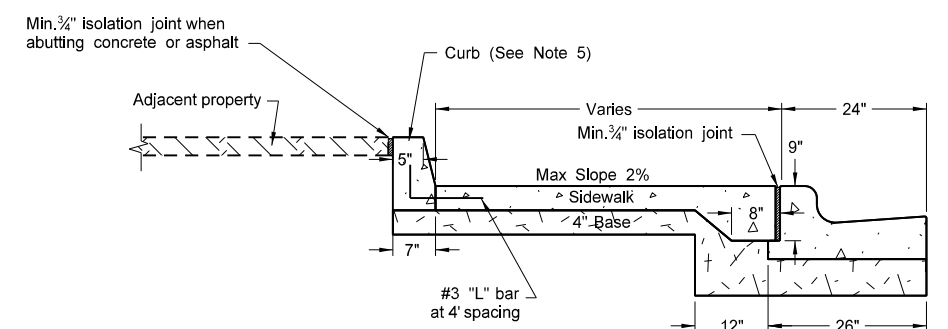
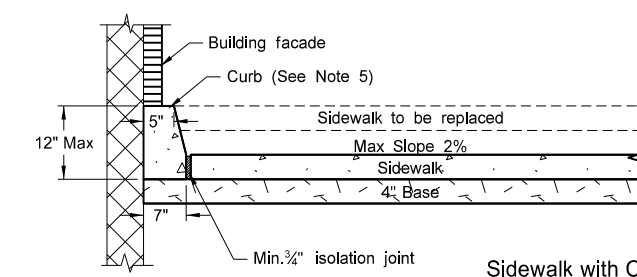
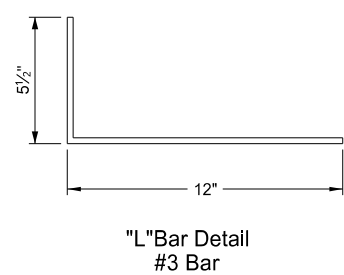
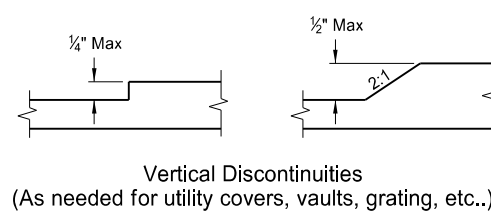
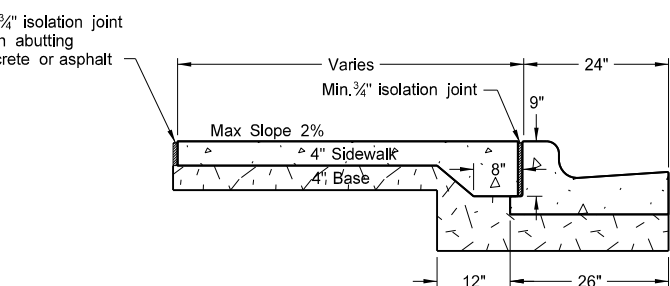
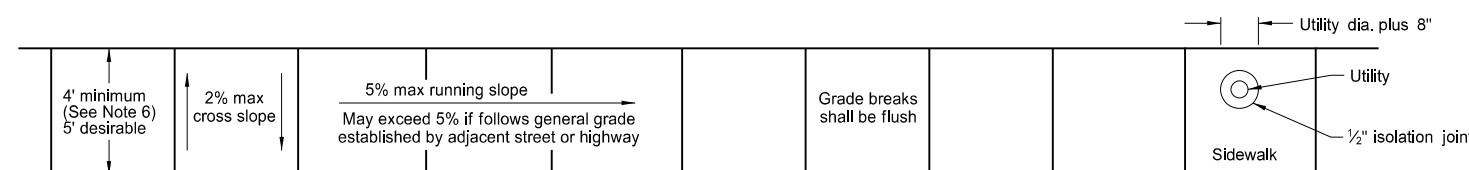
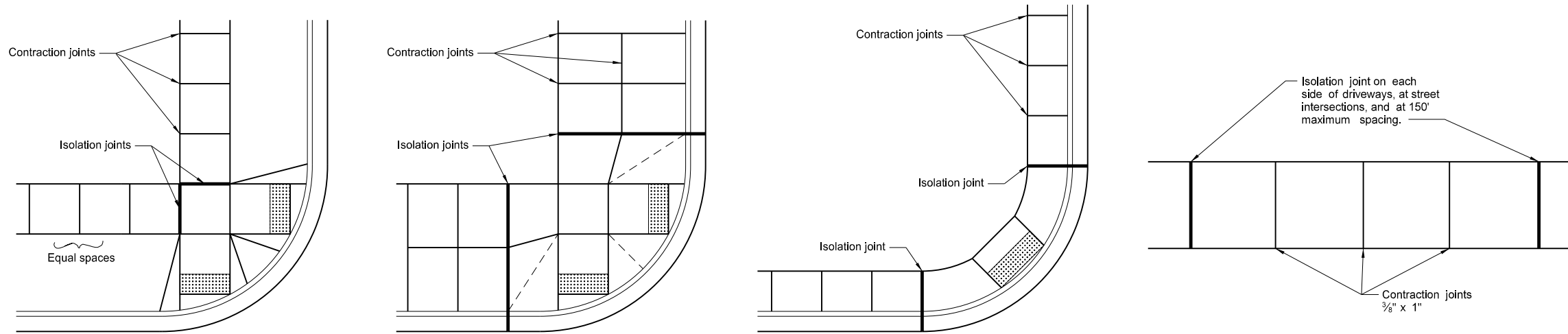

NORTH DAKOTA DEPARTMENT OF TRANSPORTATION	
11-26-13	
REVISIONS	
DATE	CHANGE
10-17-17	Updated to active voice.
09-05-18	Added sidewalk details for width and grade and passing lane requirements.
08-27-19	New Design Engineer PE Stamp.

This document was originally issued and sealed by
Kirk J Hoff,
Registration Number
PE-4683,
on 08/27/19 and the original document is stored at the North Dakota Department of Transportation

CURB RAMP RETROFIT DETAILS

D-750-3

NOTES:

- Ramp width is the useable portion of the ramp, excluding flares. Match curb ramp width to Existing Pedestrian Facility (EPF) width (4' minimum or 5' for island ramps.) Match ramp width to existing shared use path width. Maximum ramp length is 15'.
- Provide turning space with desirable 5' x 5' size or larger and minimum 4' x 4' unconstrained size, for any change of direction. Provide landing 5' long x width of path at the bottom and top of parallel ramps and at the top of perpendicular ramps. Turning spaces and Landings may overlap.
- Match detectable warning panel width to ramp width. Radial panels are allowed. Place detectable warning panel within the lower turning space.
- Provide a continuous 4' minimum width EPF with 1.5% preferred cross slope and max 2% constructed cross slope.
- Modify existing ground slope with landscaping, as needed. If not possible, use a vertical curb as detailed on Standard D-750-2. The Engineer will measure curb at the unit price bid for "Curb - Type I" per lineal foot.
- Islands: If the profile of the island curb ramp is 2% or less, provide a minimum distance of 2' between warning panels. If the profile of the island curb ramp is steeper than 2%, provide a turning space between the ramps.
- Provide generally planar vertical alignments. Provide grade breaks, perpendicular to the direction of the pedestrian travel, at the top and bottom of curb ramps (1.5% preferred, 2% max constructed cross slope).
- See Curb Ramp Retrofit Details Standard D-750-4 for additional information. Also See PROWAG for full compliance in the curb ramp area.
- Grade transitions shall be flush.

LEGEND:

- : Detectable Warning Panel.
- : Landscaping.
- : Transitional tie-in to nearest joint, if needed.
- : Curb Ramp Retrofit Transitional Area (See Standard Drawing D750-4)
- : 4' long x width of EPF or 4' minimum Clear space outside traffic lanes of travel. 1.5% preferred cross slope 2% maximum cross slope 4.7% preferred running and counter slope 5% maximum running and counter slope
- (TS)** : Turning Space Use at top of ramp or when changing directions. 1.5% preferred slope (2% maximum) all directions.
- (R)** : Preferred Ramp Grade = 5% to 7.5%. Maximum Constructed Grade = 8.3%. Preferred Cross Slope = 1.5%. Maximum Constructed Cross Slope = 2%.
- (B)** : 1.5% preferred cross slope 2% maximum constructed cross slope running slope consistent with the EPF 4.7% preferred max counter slope 5.0% max constructed counter slope
- (10)** : 10:1 maximum constructed slope.
- (4)** : 4:1 maximum constructed slope.
- 0", 3", or 6" : Curb Height.

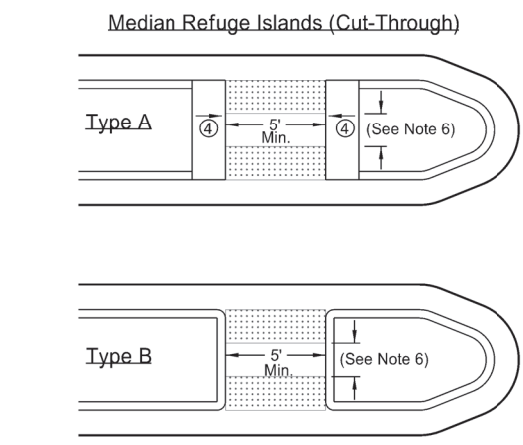
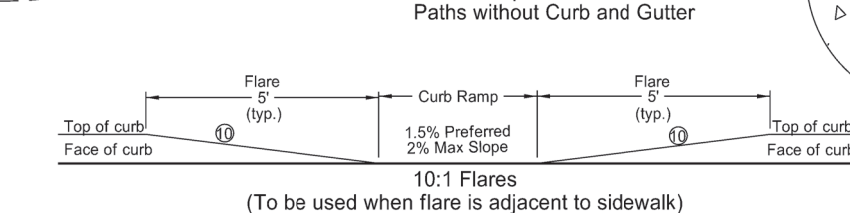
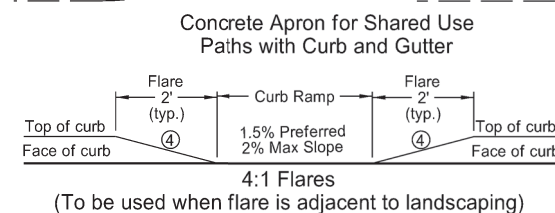
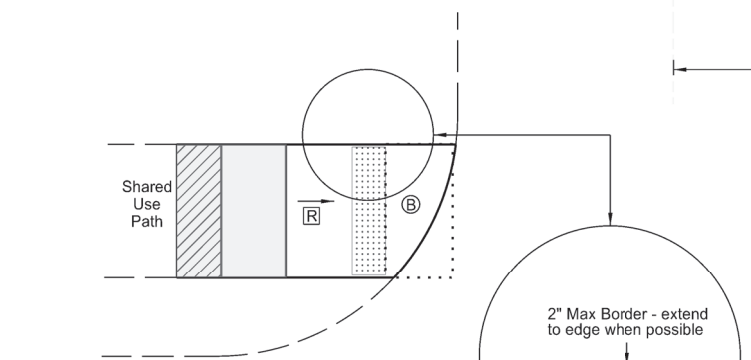
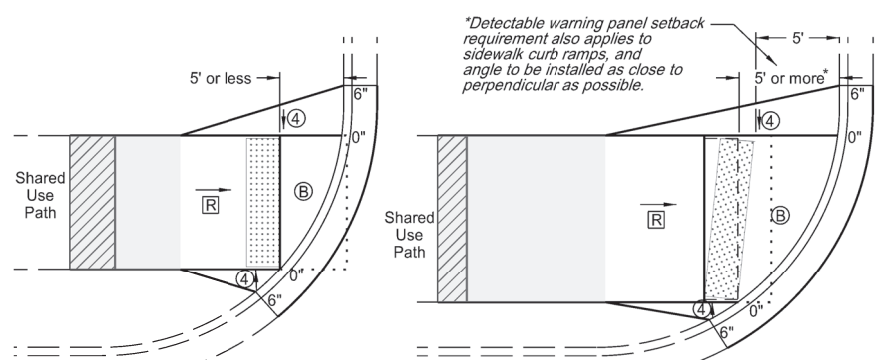
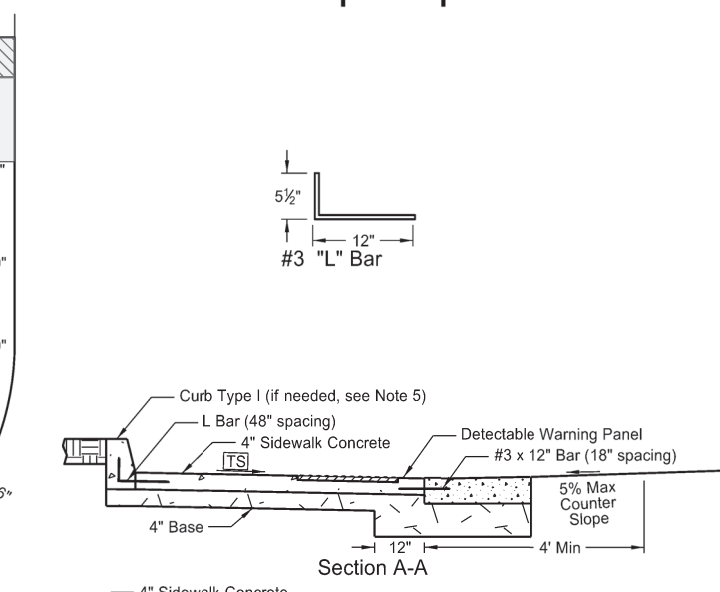
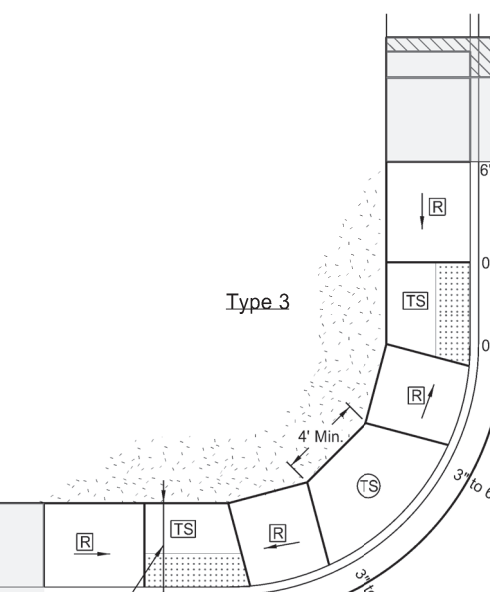
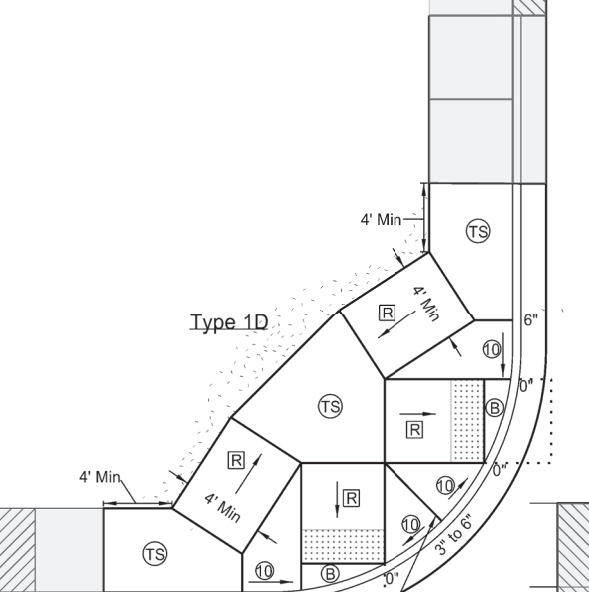
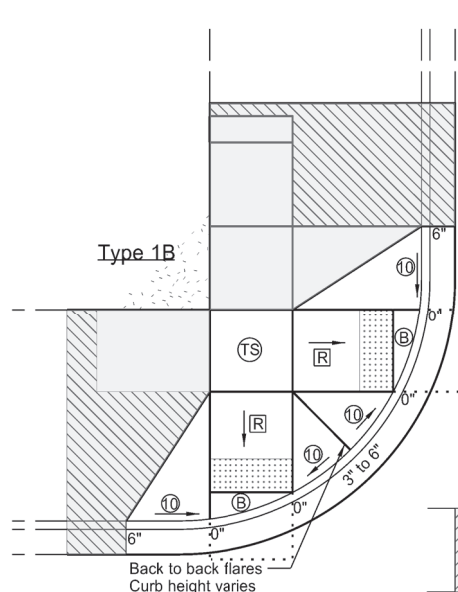
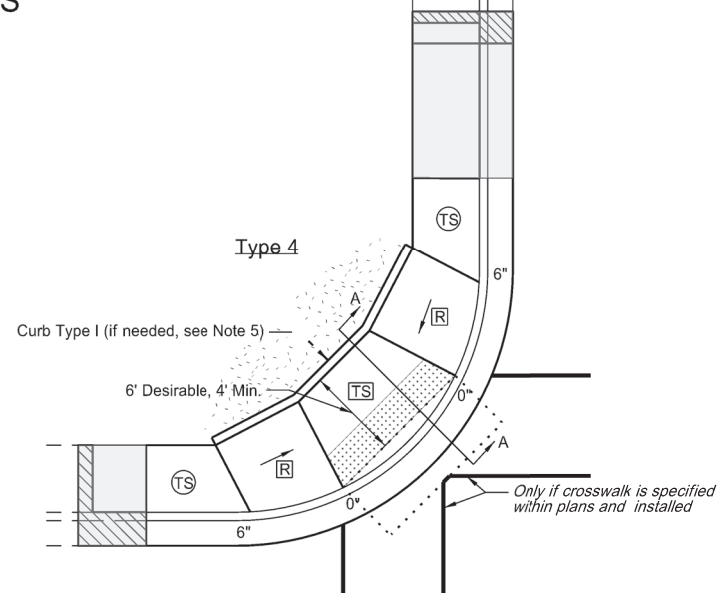
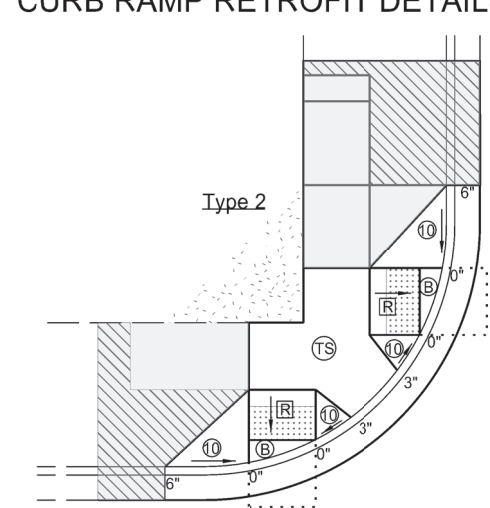
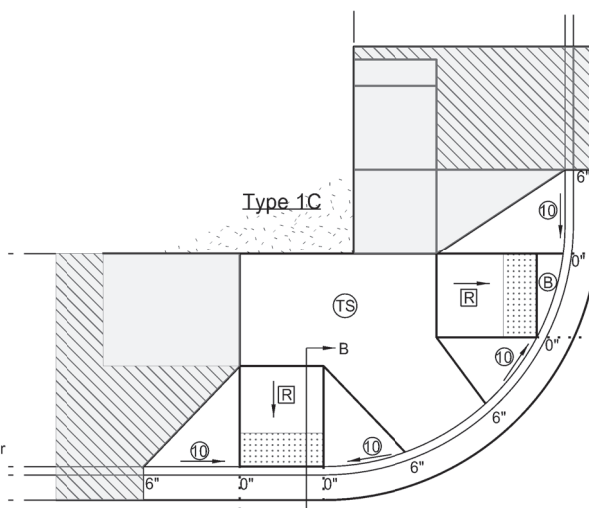
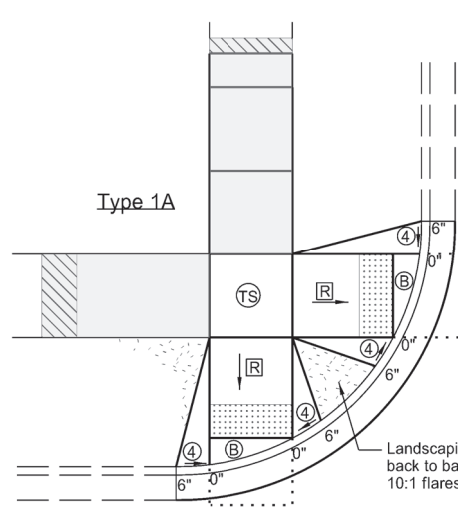

NORTH DAKOTA DEPARTMENT OF TRANSPORTATION	
11-26-13	
REVISIONS	
DATE	CHANGE
10-17-17	Updated to active voice.
09-05-18	Revised Notes, Revision for Turning Space, Added Passing Space Requirements, Turned Detectable Warning Panel
03-15-21	Slope & other clarifications.
05-19-21	Separate Curb Ramp Transition Area from Curb Ramp area

KIRK J. HOFF
REGISTERED
PROFESSIONAL
PE-4683
ENGINEER
NORTH DAKOTA
05 19 2021

LETTER AND ARROW DETAILS

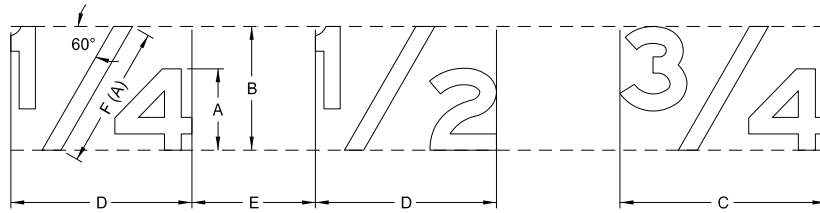

DETERMINE SIZE OF THE FRACTION AS FOLLOWS:

SYMBOL	TITLE	RATIO TO HEIGHT OF CAPITAL OR UPPER CASE
A	Letter height	1.0 of capital or upper case
B	Fraction height	1.5 X A
C	Fraction width	2.5 X A
D	Fraction width	2 X A
E	Space to next character	1 to 1.5 X A
F(A)	Length of diagonal	1.75 X A

(A) Center diagonal stroke of fraction optically.

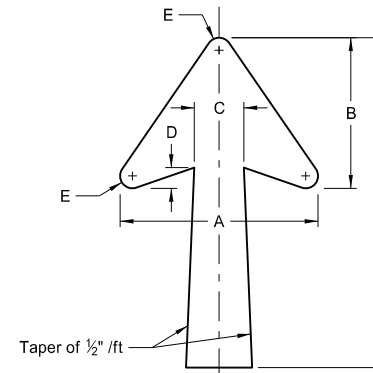

TYPE A

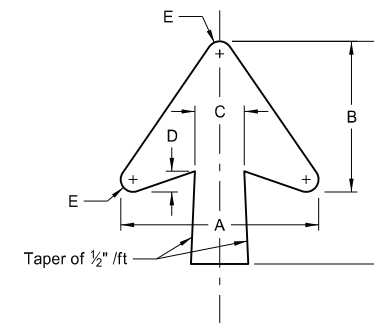

TYPE B

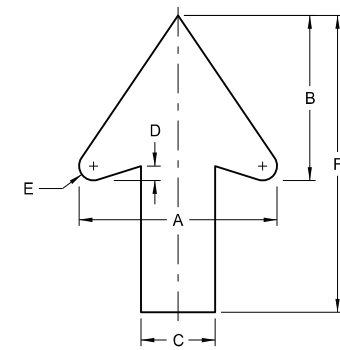

TYPE D

DESIGNATION	LETTER SIZE (Upper Case)	A	B	C	D	E	F	G
ND_6IN	6"	12"	9.125"	3"	1"	0.625"	20"	13.5"
ND_8IN	8"	15.125"	11.563"	3.75"	1.313"	0.813"	25"	17"
ND_10IN	10"	18.25"	14"	4.5"	1.5"	0.75"	30"	20"
ND_12IN	12"							
ND_13IN	13.3"	22.25"	17"	5.375"	1.75"	1"	35"	25"
ND_16IN	16"							
ND_20IN	20"							

NOTE: Arrow size on gore signs is based on the letter size of "EXIT".

DESIGNATION	LETTER SIZE (Upper Case)	A	B	C	D	E	F
ND_2IN	2"	2"	1.625"	0.75"	0.125"	0.125"	3"
ND_4IN	4"	4"	3.313"	1.5"	0.25"	0.25"	6"
ND_6IN	6"	6"	4.875"	2.25"	0.375"	0.375"	9"
ND_8IN	8"	8"	6.625"	3"	0.5"	0.5"	12"
ND_10IN	10"	10"	8.375"	3.75"	0.75"	0.75"	15"
ND_12IN	12"	12"	10"	4.5"	0.875"	0.875"	18"

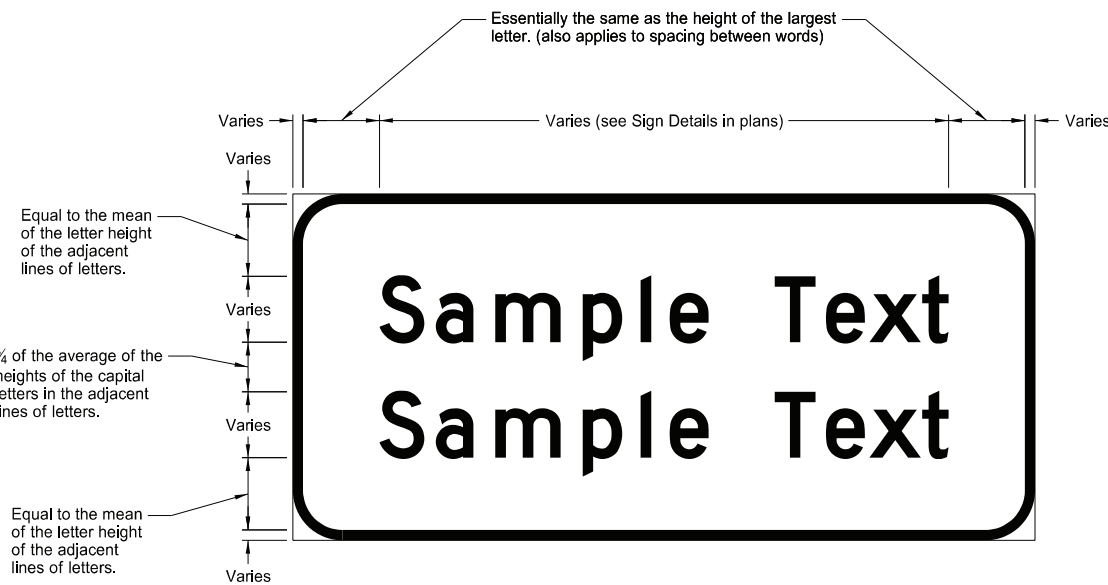

TYPICAL SPACING

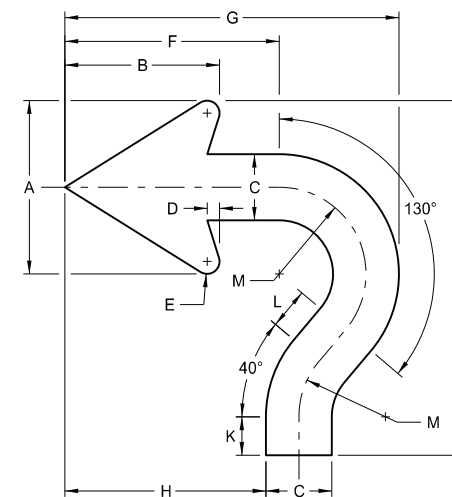

ROUNDABOUT

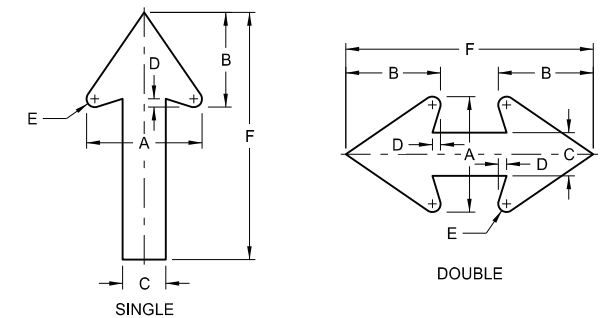

SPECIAL

DESIGNATION	A	B	C	D	E	F	USES
ND_0.75IN	2"	1.625"	0.75"	0.125"	0.125"	7.75"	Parking Signs (Regulatory)
ND_2.625IN	7"	5.75"	2.625"	0.5"	0.5"	15"	Frontage Road Signs

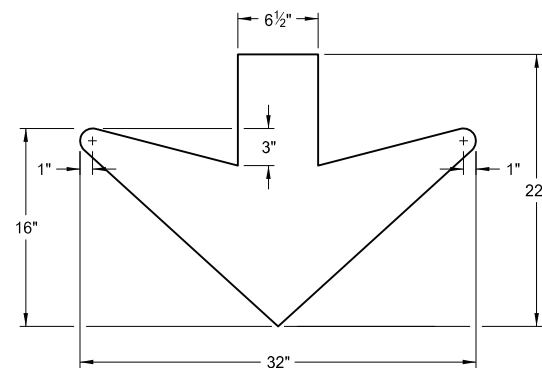

DOWN ARROW

DESIGNATION	LETTER SIZE (Upper Case)	A	B	C	D	E	F	G	H	J	K	L	M
ND_6IN	6"	5.25"	4.688"	2"	0.375"	0.375"	6.5"	10.125"	6.094"	10.75"	1.168"	1.25"	2.625"
ND_8IN	8"	7"	5.75"	2.625"	0.5"	0.5"	8.688"	13.5"	8.166"	14.333"	1.557"	1.667"	3.5"

NORTH DAKOTA DEPARTMENT OF TRANSPORTATION	
8-3-11	
REVISIONS	
DATE	CHANGE
7-8-14	Revised gore sign and added 4" D & D arrow
5-4-16	Revised Distance & Destination and Typical Spacing details
4-23-18	Revised arrow details
8-30-18	Updated notes to active voice.
8-29-19	New Design Engr PE Stamp.
8-05-24	Electronic Stamp/Signature.



08/05/24

STATE HIGHWAY ROUTE SHIELD DETAIL

D-754-11

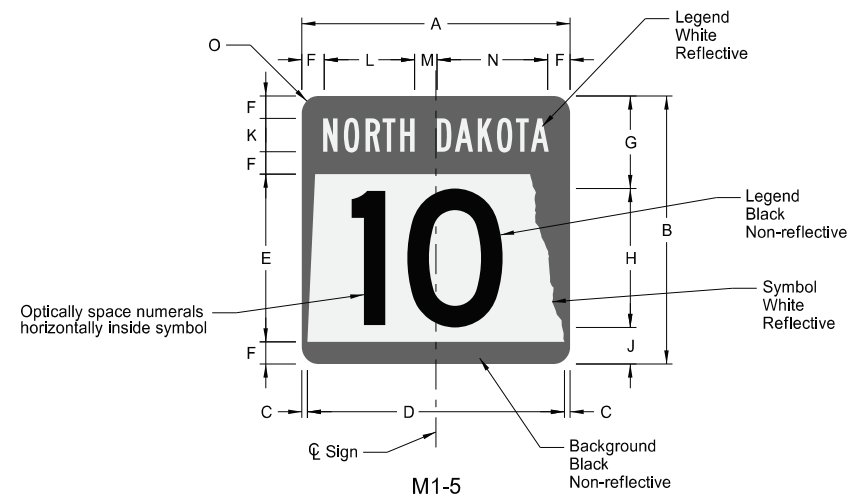

STATE ROUTE MARKER

SIGN	DIMENSION (INCHES)													
	A	B	C	D	E	F	G	H	J	K	L	M	N	O
1, 2 digits	18*	18*	0.38	17.25	11.25	1.5	6.38	9 D**	2.63	2.25 B	6.1	1.5	7.4	1.5
1, 2 digits	24	24	0.5	23	15	2	8.5	12 D**	3.5	3 B	8.1	2	9.9	1.5
1, 2 digits	36	36	0.75	34.5	22.5	3	12.75	18 D**	5.25	4.5 B	12.1	3	14.9	2.25
1, 2 digits	48*	48*	1	46	30	4	17	24 D**	7	6 B	16.2	4	19.8	3

* Size not for independent use (only for use within a guide sign)
 ** Reduce numeral spacing by 25%

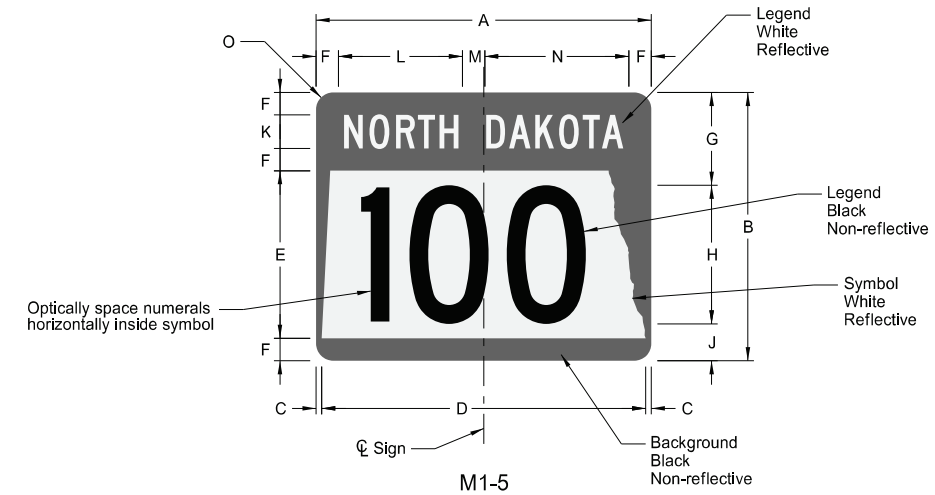

STATE ROUTE MARKER

SIGN	DIMENSION (INCHES)													
	A	B	C	D	E	F	G	H	J	K	L	M	N	O
3 digits	24*	18*	1.13	21.75	11.25	1.5	6.38	9 C**	2.63	2.25 C	8.8	2	10.2	1.5
3 digits	30	24	0.5	29	15	2	8.5	12 C**	3.5	3 C	10.7	2.5	12.8	1.5
3 digits	45	36	0.75	43.5	22.5	3	12.75	18 C**	5.25	4.5 C	16.1	3.8	19.1	2.25
3 digits	60*	48*	1	58	30	4	17	24 C**	7	6 C	21.5	5	25.5	3
4 digits	24*	18*	1.13	21.75	11.25	1.5	6.38	9 B***	2.63	2.25 C	8.8	2	10.2	1.5
4 digits	30	24	0.5	29	15	2	8.5	12 B***	3.5	3 C	10.7	2.5	12.8	1.5
4 digits	45	36	0.75	43.5	22.5	3	12.75	18 B***	5.25	4.5 C	16.1	3.8	19.1	2.25
4 digits	60*	48*	1	58	30	4	17	24 B***	7	6 C	21.5	5	25.5	3

* Size not for independent use (only for use within a guide sign)
 ** Reduce numeral spacing by 25%
 *** Reduce numeral spacing by 50%

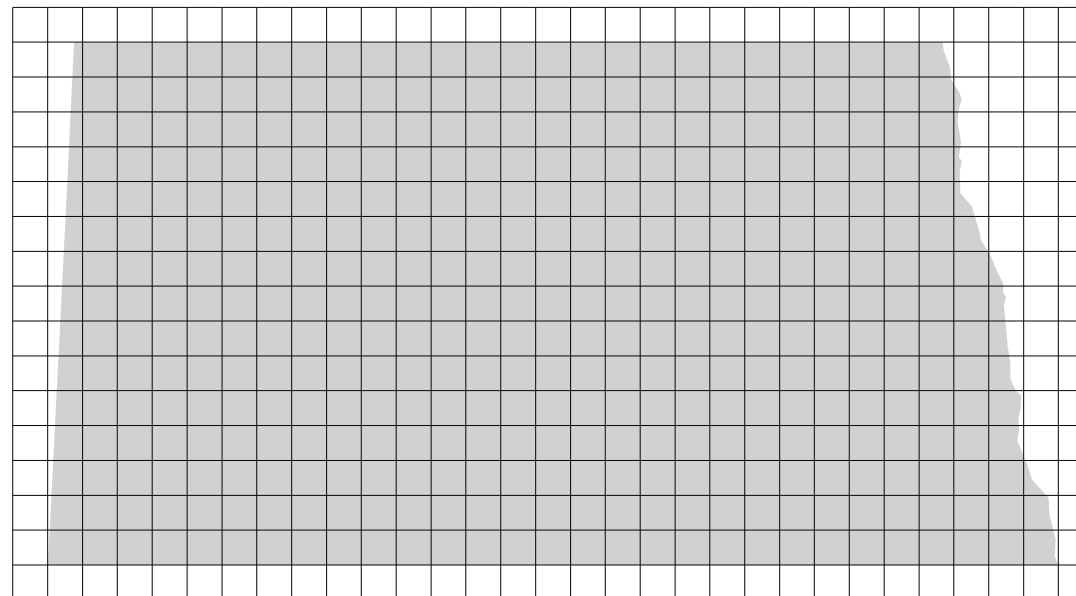
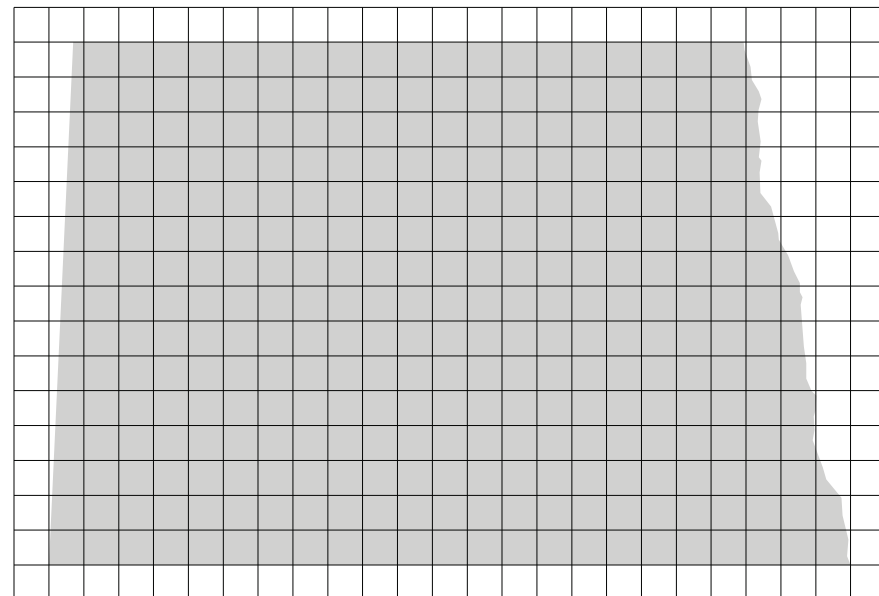

Note: North Dakota symbol graphics file may be obtained from the Design Division of North Dakota Department of Transportation.

NORTH DAKOTA DEPARTMENT OF TRANSPORTATION	
4-23-18	
REVISIONS	
DATE	CHANGE
8-23-19 8-05-24	New Design Engineer PE Stamp. Electronic Stamp/Signature.



08/05/24

APPROACH DELINEATION

D-754-22C

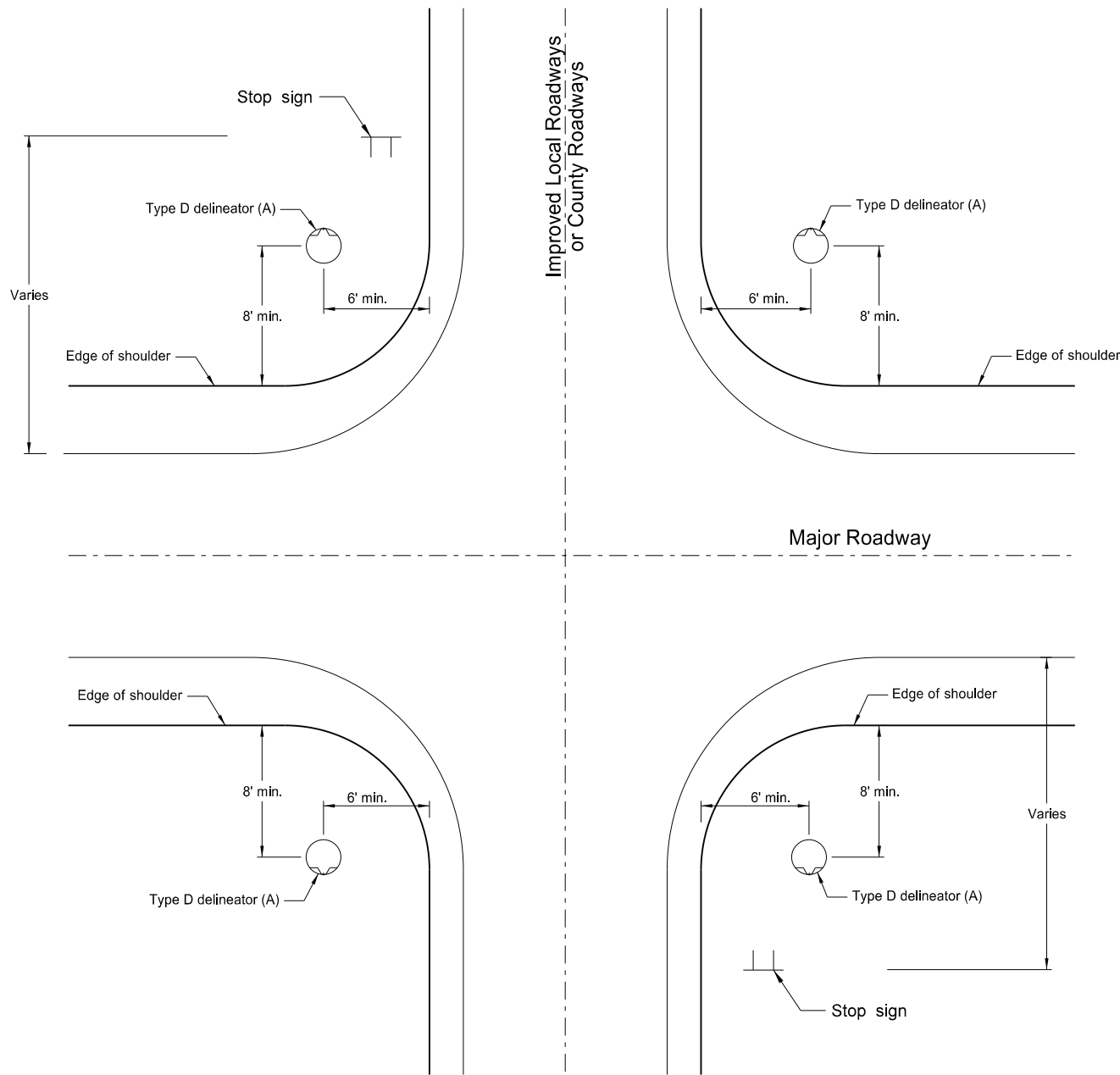

(A) Install delineators as shown in the plan layout. When a stop sign is present, place a delineator on the stop sign post at the height shown for the delineator. Place the opposite delineator directly across from the stop sign.

(B) Drill only those holes required to attach reflectors on the post or provide posts with holes the entire length at 1" centers.

(C) Use tension pin type or other non-rust vandal resistant 3/8" diameter fastener with a min 13/16" outside diameter flat washer.

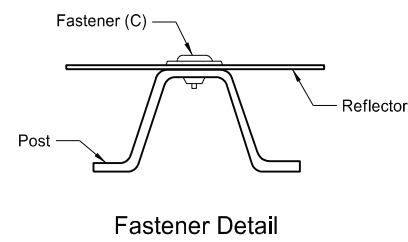
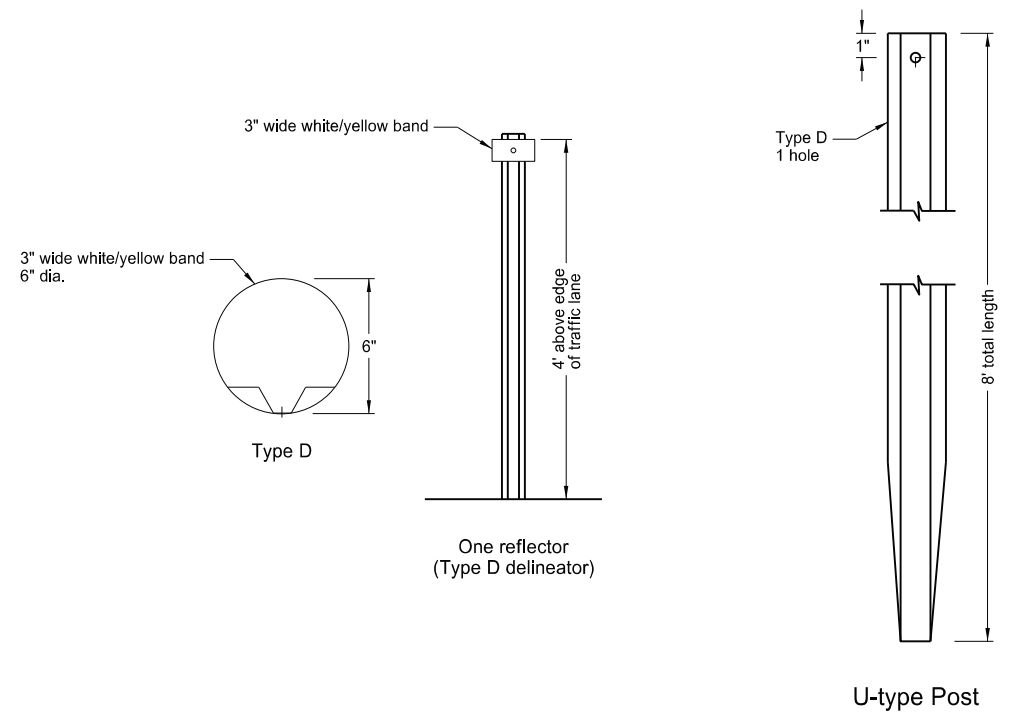

Fastener Detail

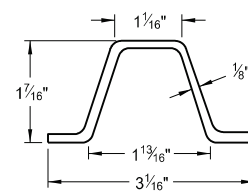

Steel Post Detail
(approx. 2 lb/ft)

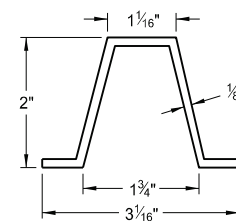

Aluminum Post Detail
(approx. 0.88 lb/ft)

NORTH DAKOTA DEPARTMENT OF TRANSPORTATION	
8-22-12	
REVISIONS	
DATE	CHANGE
8-30-18	Updated notes to active voice.
8-29-19	New Design Engineer PE Stamp.
8-05-24	Electronic Stamp/Signature.



08/05/24

PERFORATED TUBE ASSEMBLY DETAILS

D-754-23

Notes:

1. Curbed Roadways: Use a 3' clearance from face of the curb except where right of way or sidewalk width is limited; Use a minimum 2' clearance. Increase the horizontal clearance if required to maintain a minimum sidewalk clear width of 4' from the sign support, not including any attached curb.
2. Minimum vertical clearance: Provide at least 5' measured from the bottom of the sign to the edge of the driving lane or auxiliary lane at the side of the road in rural districts. Provide at least 7' clearance to the bottom of the sign, where parking or pedestrian movements occur.
Install signs on expressways a minimum height of 7'.
Install adopt-a-highway signs on Freeways at least 7' above the edge of the driving lane.
Maximum vertical clearance is 6" greater than the minimum vertical clearance.
3. Offset signs: Use a vertical clearance of 5' above the edge of the driving lane for signs placed 30 feet or more from the edge of the traveled way.
4. Provide a horizontal clearance from edge of shared use path to edge of sign of 3', except where width is limited. Provide a minimum clearance of 2'.

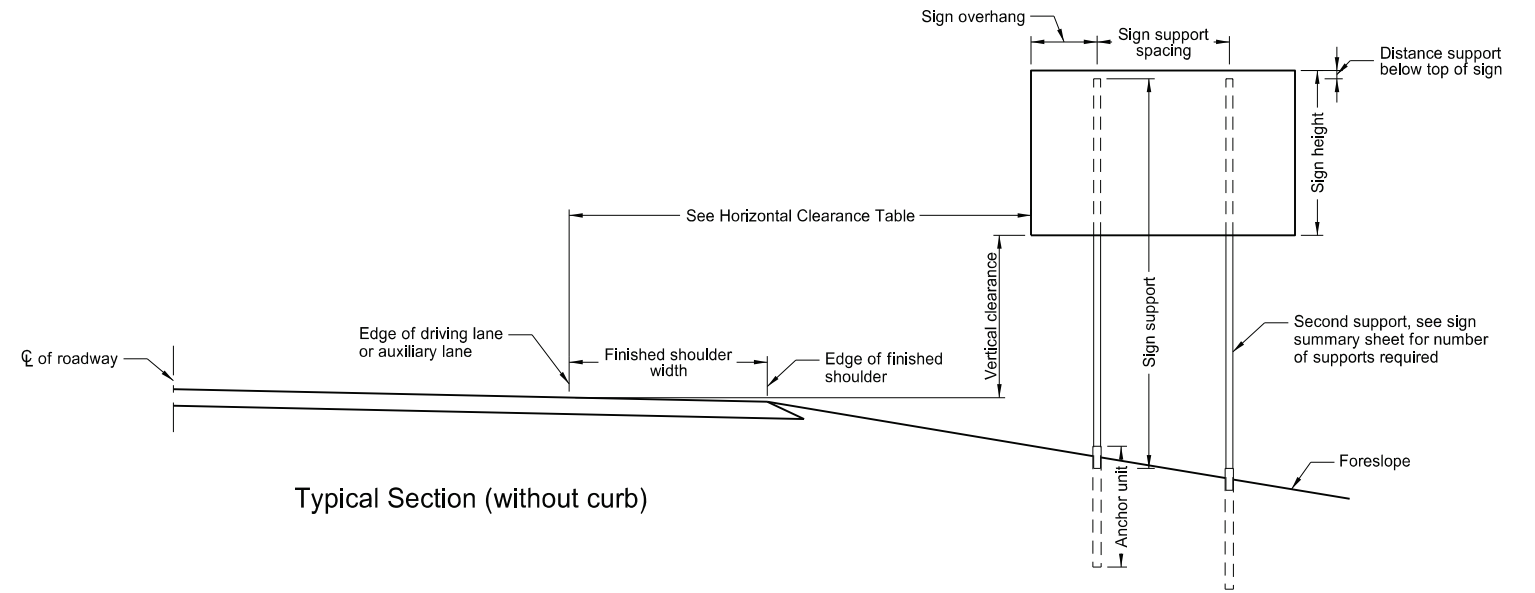

Typical Section (without curb)

Shoulder Width ft	Offset ft
0 to 2	16
>2 to 4	18
>4 to 6	20
>6 to 8	22
>8 to 10	24

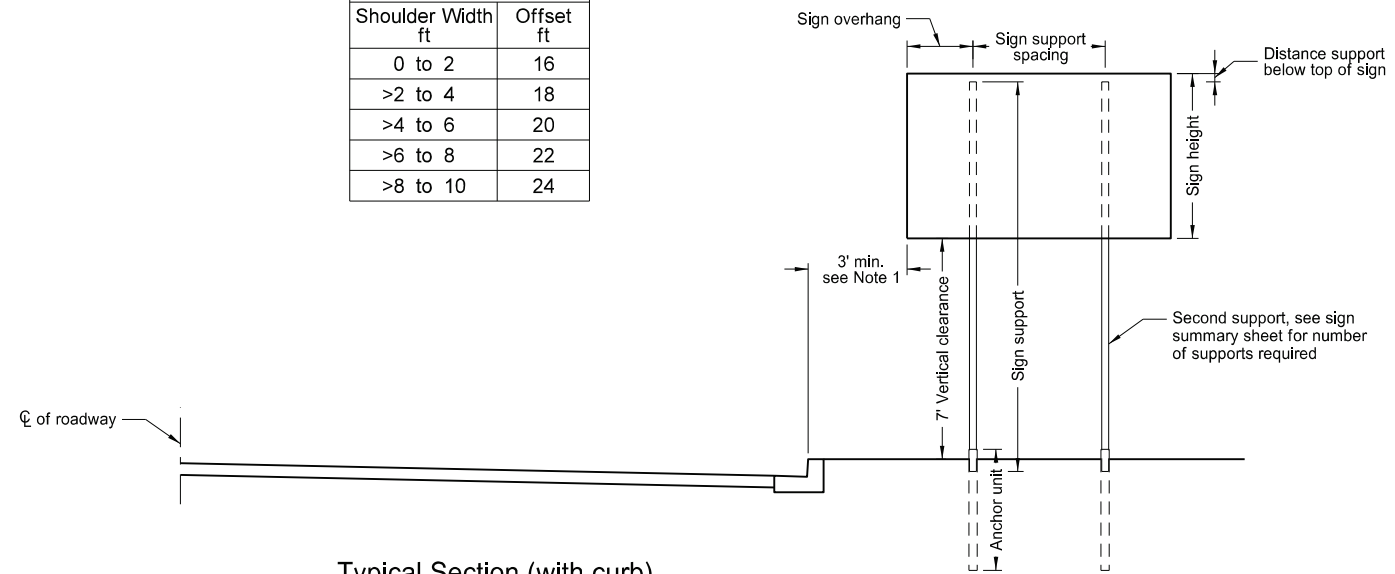

Typical Section (with curb)
Residential or Business District

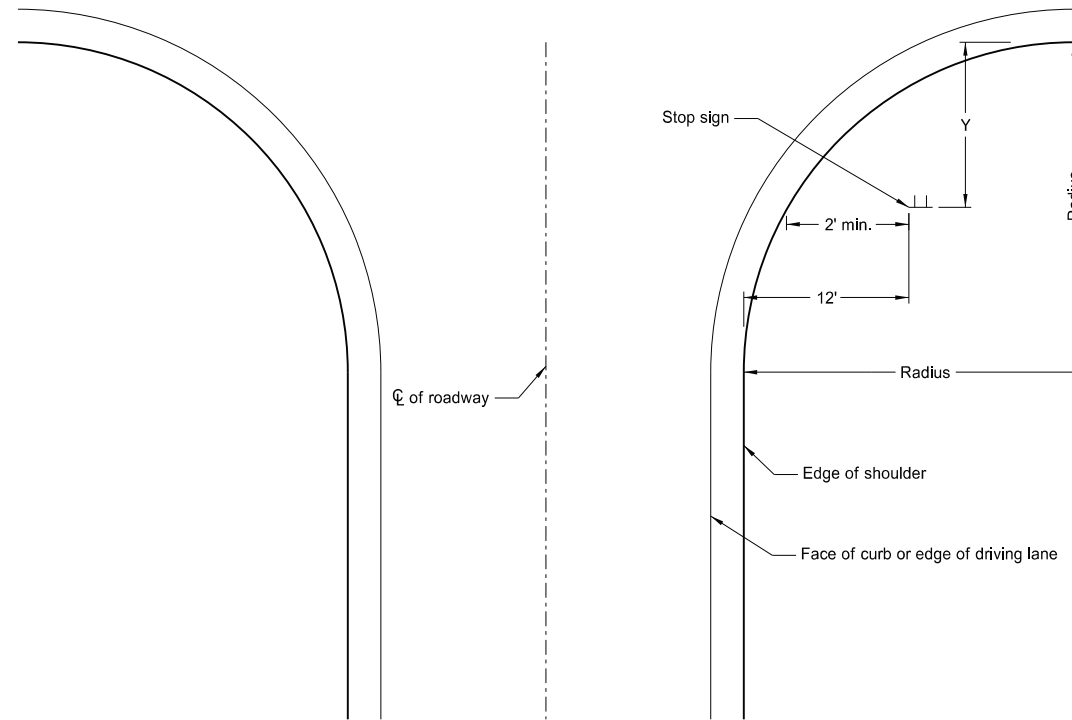

Stop Sign Location
Wide Throat Intersection

Use layout for the placement of "Stop" signs.

Radius ft.	Y-max. ft.	Y-min. ft.
40	50	15
45	50	18
50	50	21
55	50	25
60	50	28
65	50	32
70	50	35
75	50	39
80	50	43

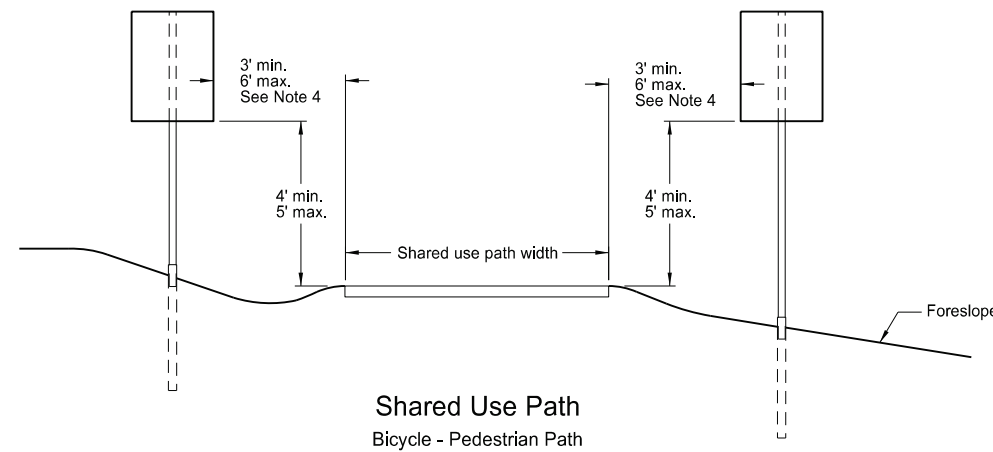

Shared Use Path
Bicycle - Pedestrian Path

NORTH DAKOTA DEPARTMENT OF TRANSPORTATION	
10-3-13	
REVISIONS	
DATE	CHANGE
7-8-14	Revised note 2, added note 4.
8-30-18	Updated notes to active voice.
8-29-19	New Design Engineer PE Stamp.
8-05-24	Electronic Stamp/Signature.



08/05/24

Telescoping Perforated Tube							
Number of Posts	Post Size In.	Wall Thickness Gauge	Sleeve Size In.	Wall Thickness Gauge	Slip Base	Anchor Size Without Slip Base In.	Anchor Wall Thickness Gauge
1	2	12			No	2 1/4	12
1	2 1/4	12			No	2 1/2	12
1	2 1/2	12			(B)	3(C)	7
1	2 1/2	10			Yes		7
1	2 1/4	12	2 1/2(D)	12	Yes		7
1	2 1/2	12	2 1/4	12	Yes		7
2	2 1/2	10			Yes		7
2	2 1/4	12	2 1/2(D)	12	Yes		7
2	2 1/2	12	2 1/4	12	Yes		7
3 & 4	2 1/2	12			Yes		7
3 & 4	2 1/2	10			Yes		7
3 & 4	2 1/2	12	2 1/4	12	Yes		7
3 & 4	2 1/4	12	2 1/2(D)	12	Yes		7
3 & 4	2 1/2	10	2 3/8	10	Yes		7

(B) - Provide a shim as specified by the manufacturer when placing 2 1/2", 12 gauge posts in standard soils without breakaway bases. Provide breakaway base when placing the support in weak soils. The Engineer will determine if the soils are weak. Weak soils are classified as boggy, wet, or loose soil areas.
 (C) - 3" anchor unit
 (D) - 2 1/2" x 12 ga. x 18" minimum length external sleeve required.

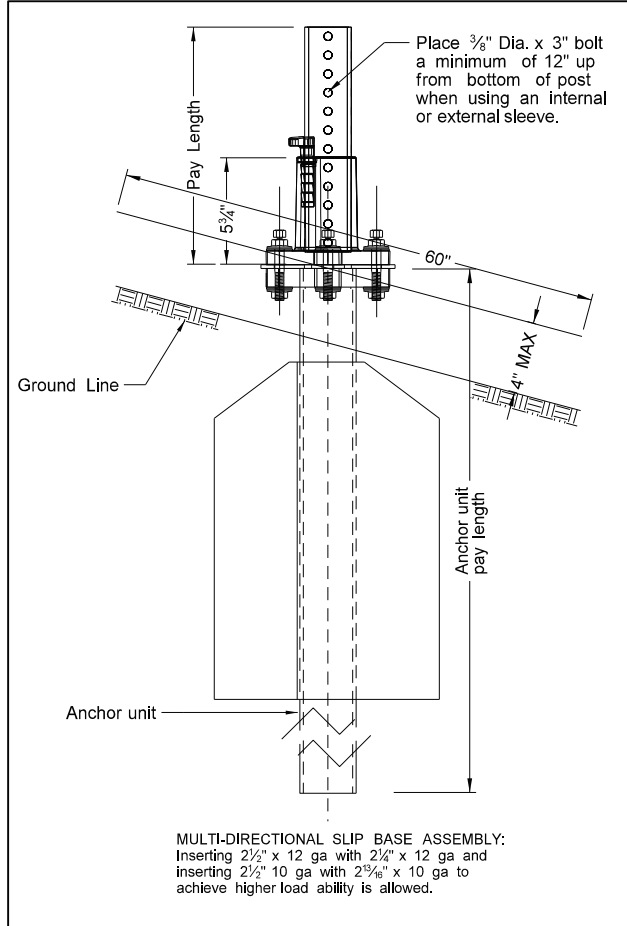
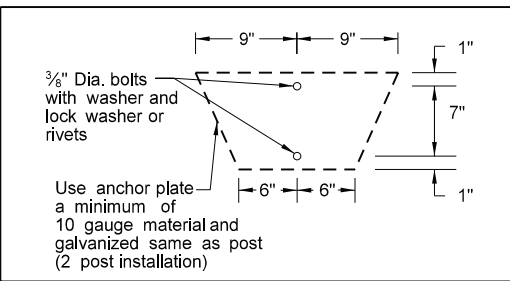

MULTI-DIRECTIONAL SLIP BASE ASSEMBLY:
 Inserting 2 1/2" x 12 ga with 2 1/4" x 12 ga and inserting 2 1/2" 10 ga with 2 3/8" x 10 ga to achieve higher load ability is allowed.

Mounting Details Perforated Tube

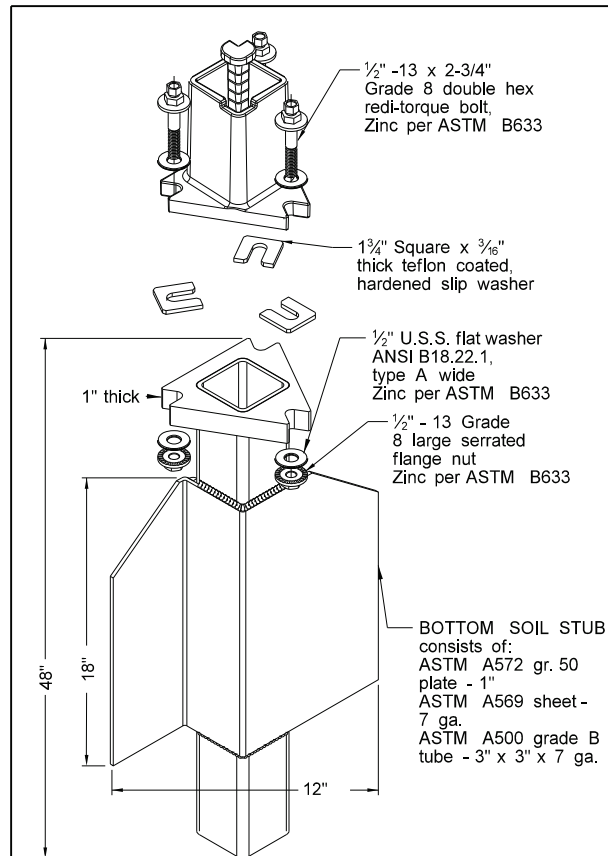

SLIP BASE FOR 2 1/2" POST

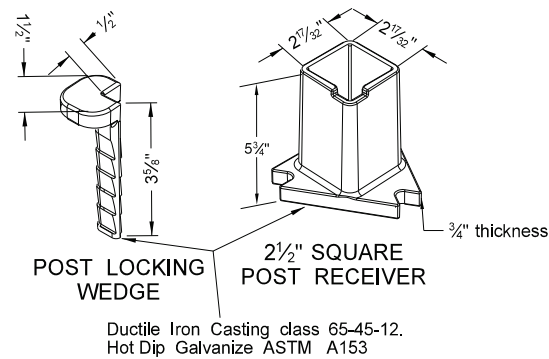

2 1/2" SQUARE POST RECEIVER
 Ductile Iron Casting class 65-45-12, Hot Dip Galvanize ASTM A153

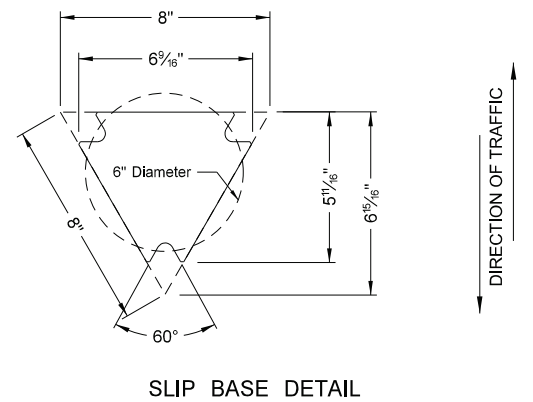

SLIP BASE DETAIL

Properties of Telescoping Perforated Tubes							
Tube Size In.	Wall Thickness In.	U.S. Standard Gauge	Weight Per Foot Lbs.	Moment of Inertia In. ⁴	Cross Sect. Area In. ²	Section Modulus In. ³	
1 1/2 x 1 1/2	0.105	12	1.702	0.129	0.380	0.172	
2 x 2	0.105	12	2.416	0.372	0.590	0.372	
2 1/4 x 2 1/4	0.105	12	2.773	0.561	0.695	0.499	
2 3/8 x 2 3/8	0.135	10	3.432	0.605	0.841	0.590	
2 1/2 x 2 1/2	0.105	12	3.141	0.804	0.803	0.643	
2 1/2 x 2 1/2	0.135	10	4.006	0.979	1.010	0.783	

The 2 3/8" size 10 gauge is shown as 2.19" size on the plans; The 2 1/2" size is shown as 2.51" size on the plans.

NOTE:

- 4" Vertical clearance of anchor or breakaway base. The 4" x 60" measurement is above and below post location and also back and ahead of post.
- Provide 7 gauge HRPO commercial quality ASTM A569 and 3" x 3" x 7" gauge ASTM A500 grade B anchor material with 43.9 KSI yield strength and 59.3 KSI tensile strength. Hot dip galvanize anchor per ASTM A123/153. Tolerances on anchor unit and slip base bottom assembly are +/- 0.005" unless otherwise noted.
- Eliminate wings when anchor is used in concrete sidewalk.
- Provide a minimum 8" distance between the first and fourth post on four post signs.
- Install in accordance with manufacturers recommendation.
- Use a minimum 1/2" diameter x 4" grade 8 concrete fastener for surface mount breakaway base.

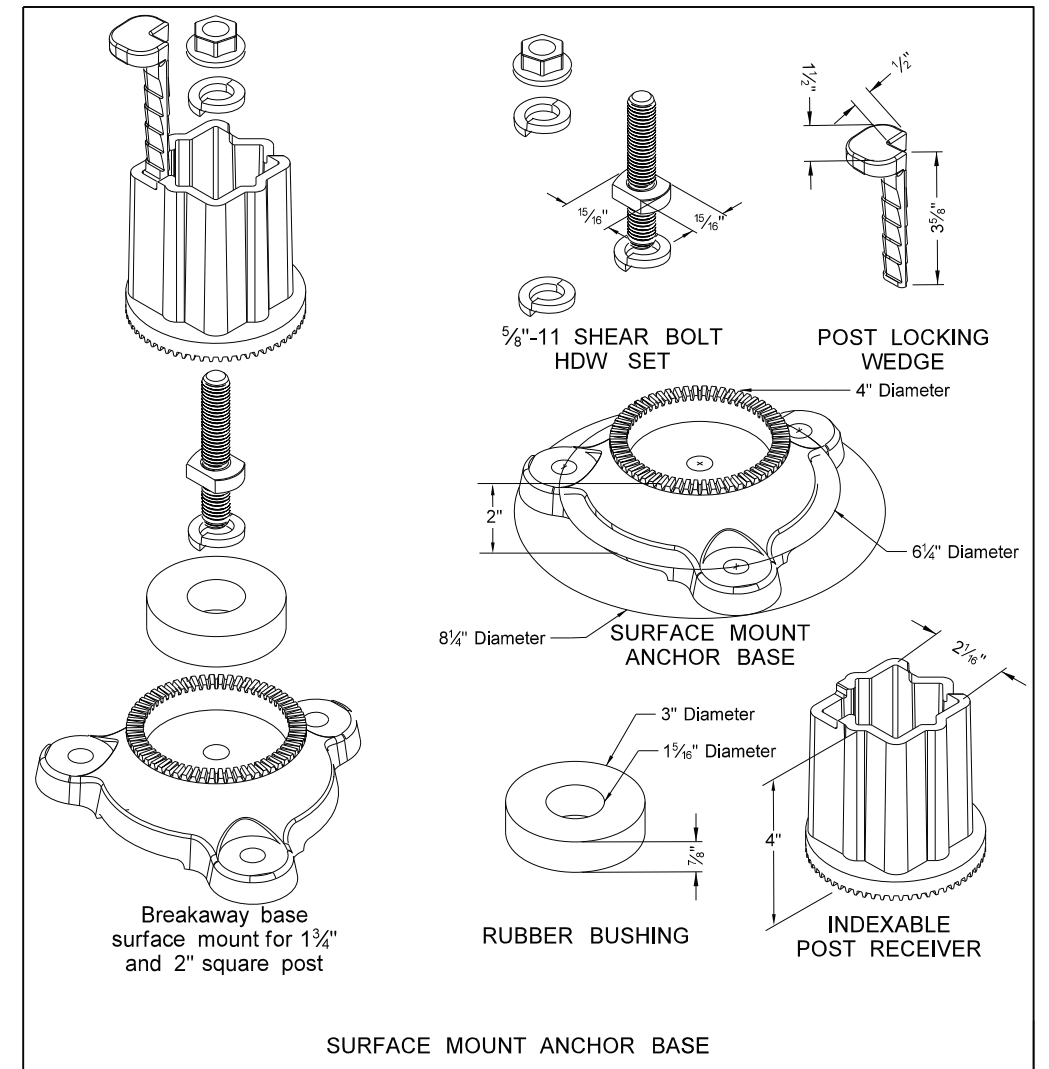

SURFACE MOUNT ANCHOR BASE

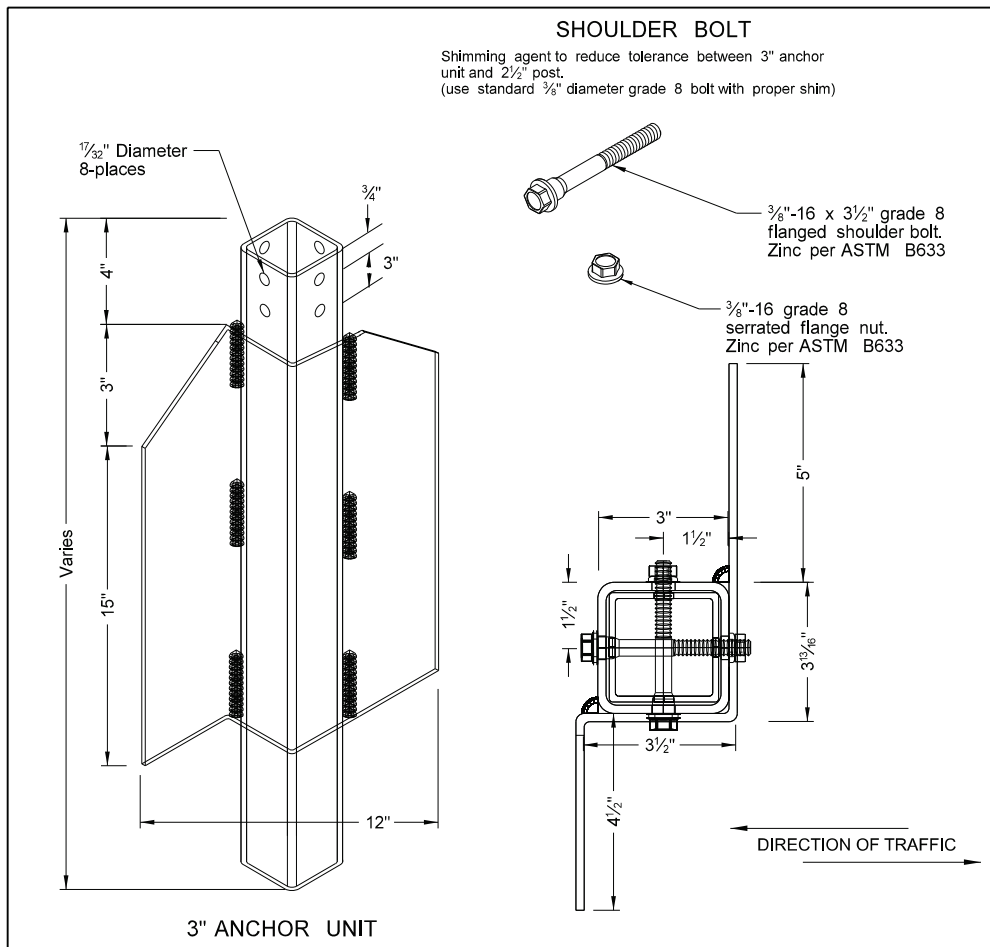

3" ANCHOR UNIT

NORTH DAKOTA DEPARTMENT OF TRANSPORTATION	
8-6-09	
REVISIONS	
DATE	CHANGE
8-30-18	Updated notes to active voice & corrected max height of base.
8-29-19	New Design Engineer PE Stamp.
8-05-24	Electronic Stamp/Signature.



08/05/24

Breakaway Coupler System for Perforated Tubes

Notes:

- 4" Vertical clearance of anchor or breakaway base. The 4" x 60" measurement is above and below post location and also back and ahead of post.
- Use anchor unit of the same size and specification as the post.
- Provide a minimum 8' distance between the first and fourth post on four post signs.
- Use the breakaway base system on standard D-754-24 or the breakaway coupling system manufactured from material meeting the requirements of ASTM A325 fasteners with the special requirements specified by DENT BREAKAWAY IND., INC. which meets the test requirements of NCHRP Report 350.

Number of Posts	Telescoping Perforated Tube						
	Post Size In.	Wall Thick-ness Gauge	Sleeve Size In.	Wall Thick-ness Gauge	Slip Base	Anchor Size Without Slip Base In.	Anchor Wall Thickness Gauge
1	2	12			No	2 1/4	12
1	2 1/4	12			No	2 1/2	12
1	2 1/2	12			(B)	3(C)	7
1	2 1/2	10			Yes		7
1	2 1/4	12	2	12	Yes		7
1	2 1/2	12	2 1/4	12	Yes		7
2	2 1/2	10			Yes		7
2	2 1/4	12	2	12	Yes		7
2	2 1/2	12	2 1/4	12	Yes		7
3 & 4	2 1/2	12			Yes		7
3 & 4	2 1/2	10			Yes		7
3 & 4	2 1/2	12	2 1/4	12	Yes		7
3 & 4	2 1/4	12	2	12	Yes		7
3 & 4	2 1/2	10	2 3/16	10	Yes		7

(B) - 2 1/2" 12 gauge posts do not need breakaway bases unless support is placed in boggy, wet, or loose soil areas.

(C) - 3" anchor unit

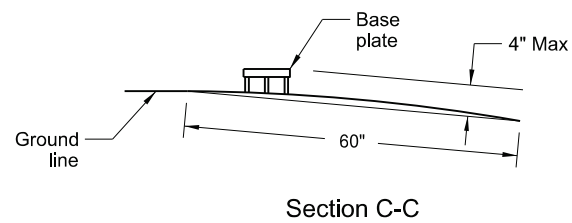
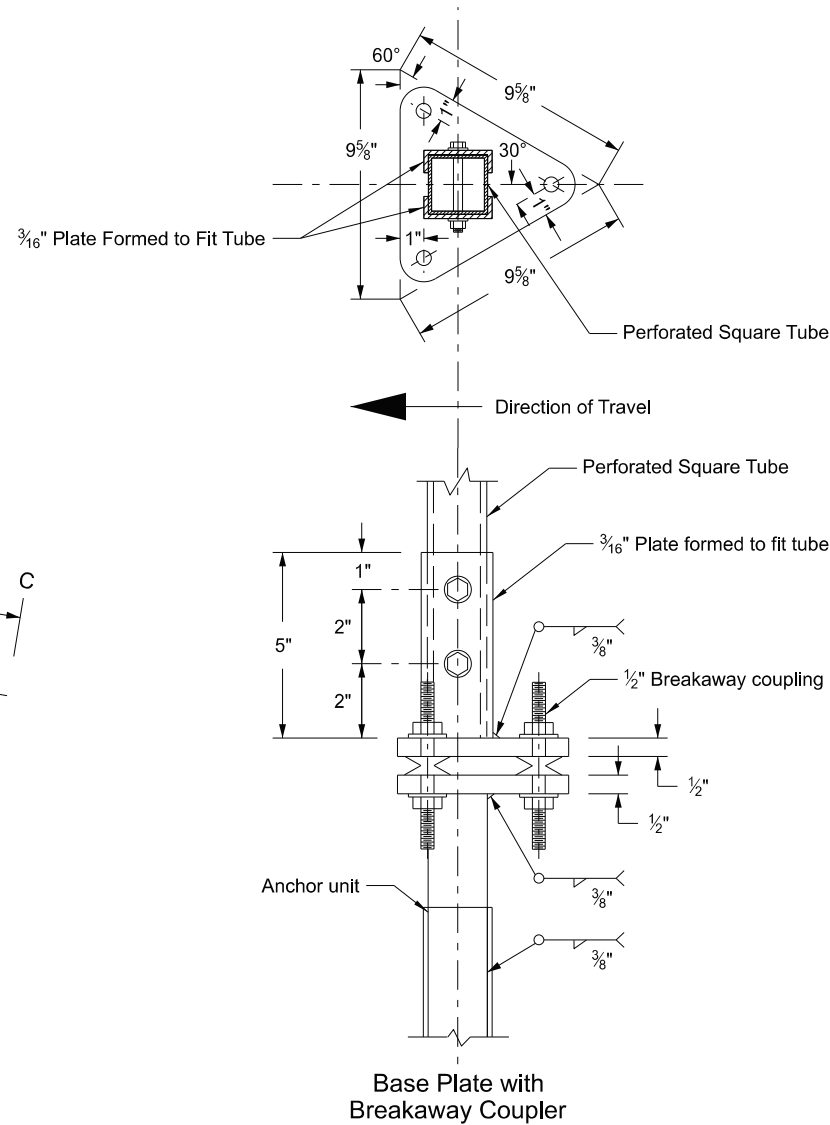
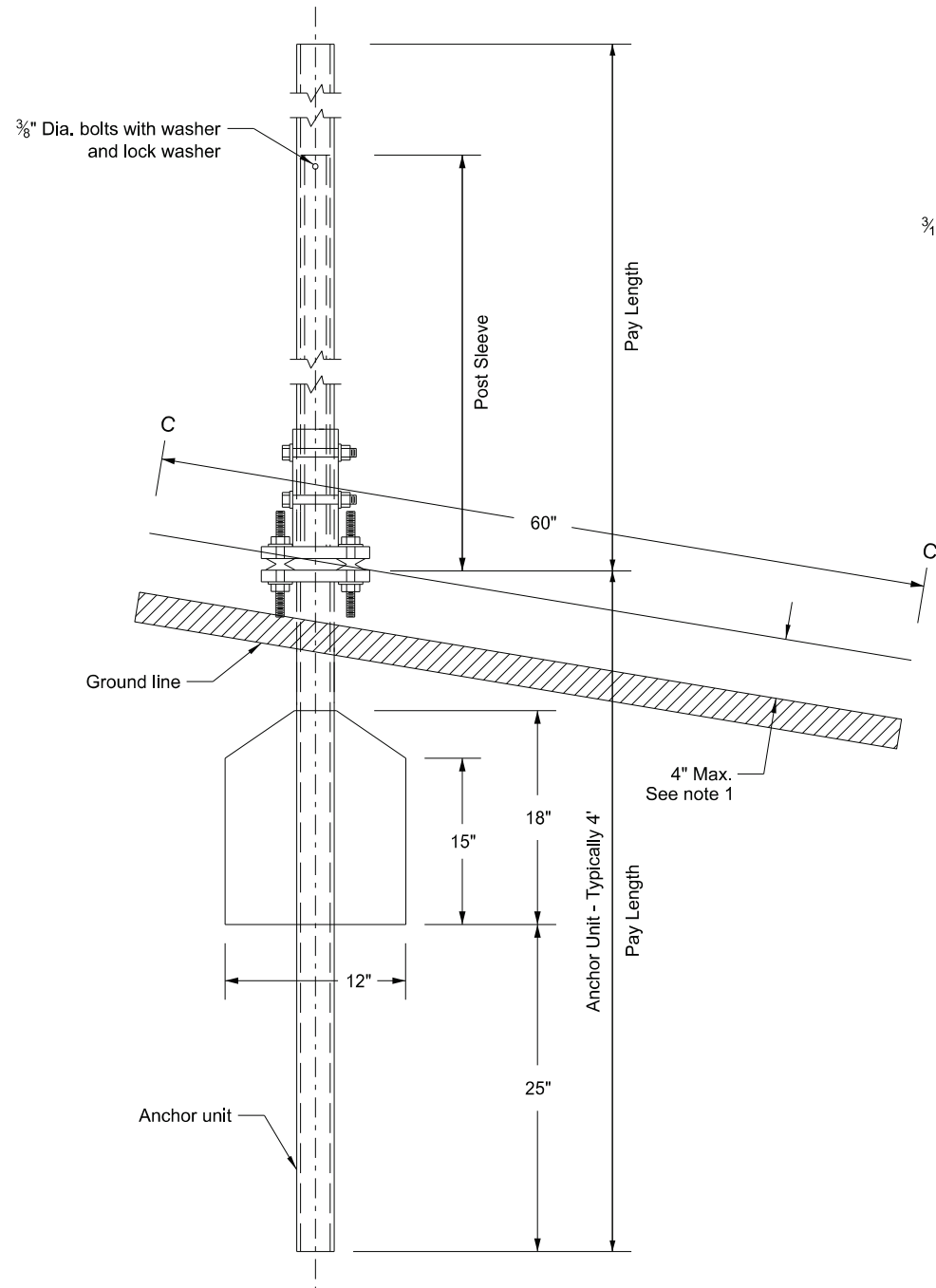

Max protection of the stub post is 4" above a 60" chord aligned radially to the center line of the highway and connecting any point, within the length of the chord, on the ground surface on one side of the support to a point in the ground surface on the other side.

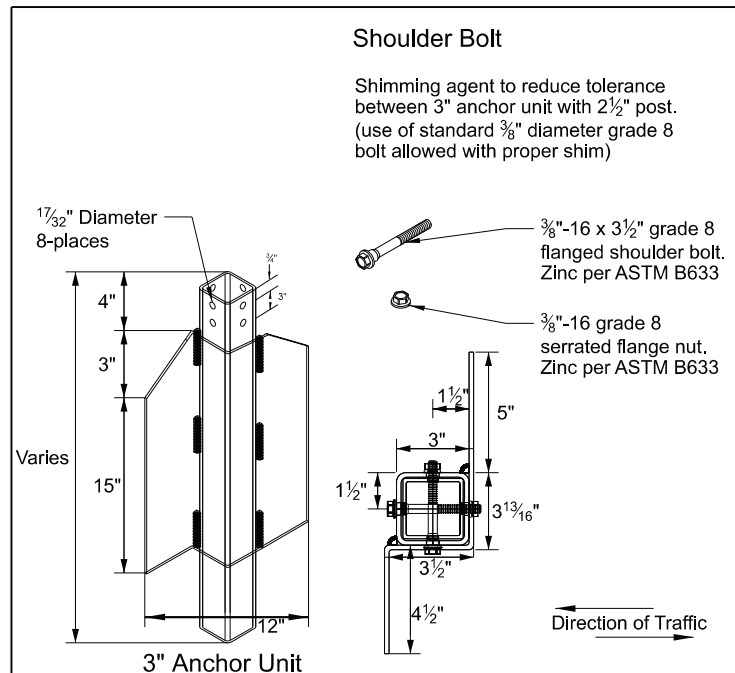

NORTH DAKOTA DEPARTMENT OF TRANSPORTATION	
10-3-2013	
REVISIONS	
DATE	CHANGE
8-30-18	Updated notes to active voice.
8-30-19	New Design Engr PE Stamp.
8-05-24	Electronic Stamp/Signature.



08/05/24

Mounting Details Perforated Tube

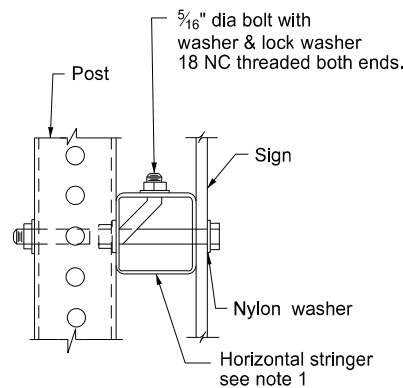

Side View

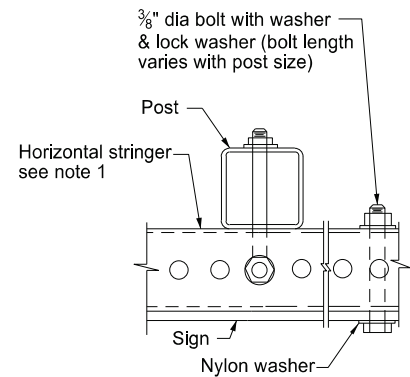

Top View

STRINGER MOUNTING
(WITH STRINGER IN FRONT OF POST)

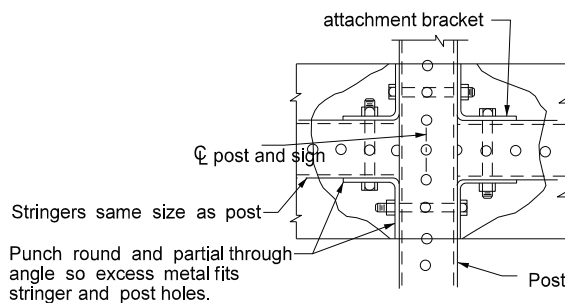

STREET NAME SIGNS AND ONE WAY SIGNS
SINGLE POST ASSEMBLY
ONE STRINGER OR BACK TO BACK MOUNTING

Note:

- Horizontal stringers - Use perforated tubes or 1 3/4" x 3/16" thick, 1.08 lbs./ft aluminum or 3.16 lbs./ft steel z bar stringers.
- Use minimum outside diameter 5/16" ± 1/16" and 10 gauge thick metal washers on sign face.
- Place No Parking signs with directional arrows at a 30 to 45 degree angle with the line of traffic flow. Turning the support to the correct angle for No Parking signs requiring the above angles is allowed. If the No Parking sign is placed with another sign that requires placement at a 90 degree angle with the line of traffic flow, use the detailed angle strap to mount the No Parking sign. Use flat washers and lock washers with all nylon washers.
- Punching the sign backing and placing the bolt through the sign, the stringer and the post is allowed in lieu of using the bent bolt to attach the post to the stringer.
- 4" vertical clearance of anchor or breakaway base. The 4" x 60" measurement is above and below post location and also back and ahead of post.

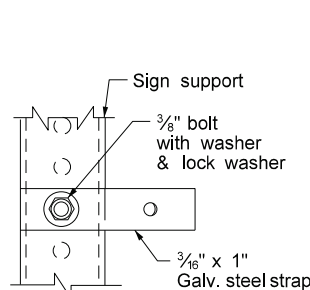

Side View

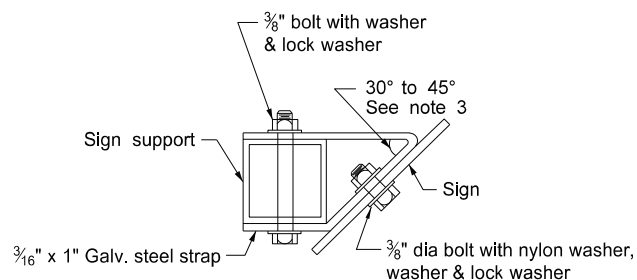

Top View

STRAP DETAIL

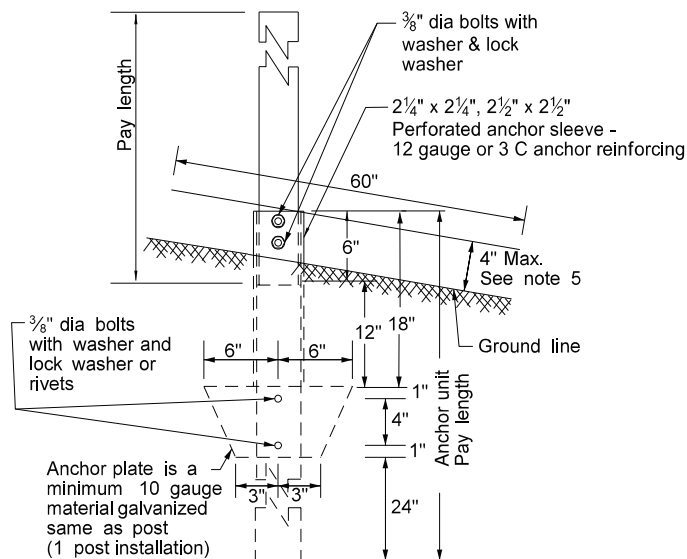

ANCHOR UNIT AND POST ASSEMBLY

Number of Posts	Telescoping Perforated Tube						
	Post Size In.	Wall Thickness Gauge	Sleeve Size In.	Wall Thickness Gauge	Slip Base	Anchor Size Without Slip Base In.	Anchor Wall Thickness Gauge
1	2	12			No	2 1/4	12
1	2 1/4	12			No	2 1/2	12
1	2 1/2	12			(B)	3(C)	7
1	2 1/2	10			Yes		7
1	2 1/4	12	2 1/2(D)	12	Yes		7
1	2 1/2	12	2 1/4	12	Yes		7
2	2 1/2	10			Yes		7
2	2 1/4	12	2 1/2(D)	12	Yes		7
2	2 1/2	12	2 1/4	12	Yes		7
3 & 4	2 1/2	12			Yes		7
3 & 4	2 1/2	10			Yes		7
3 & 4	2 1/2	12	2 1/4	12	Yes		7
3 & 4	2 1/4	12	2 1/2(D)	12	Yes		7
3 & 4	2 1/2	10	2 3/16	10	Yes		7

(B) - When placing 2 1/2", 12 gauge posts in standard soils without breakaway bases, provide a shim as specified by the manufacturer. Provide breakaway base when placing the support in weak soils. Engineer will determine if soils are weak. Weak soils are classified as boggy, wet, or loose soil areas.
(C) - 3" anchor unit
(D) - 2 1/2" x 12 ga. x 18" minimum length external sleeve required.

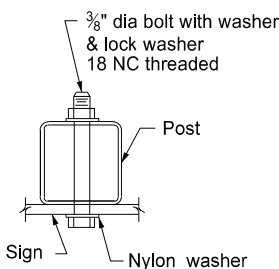

BOLT MOUNTING

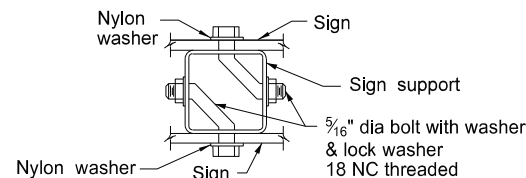

Top View

BACK TO BACK MOUNTING

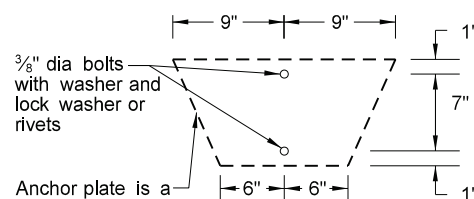

Anchor plate is a minimum 10 gauge material galvanized same as post (2 post installation)

Tube Size In.	Wall Thickness In.	U.S. Standard Gauge	Weight Per Foot Lbs.	Moment of Inertia In. ⁴	Cross Sect. area In. ²	Section Modulus In. ³
1 1/2 x 1 1/2	0.105	12	1.702	0.129	0.380	0.172
2 x 2	0.105	12	2.416	0.372	0.590	0.372
2 1/4 x 2 1/4	0.105	12	2.773	0.561	0.695	0.499
2 3/16 x 2 3/16	0.135	10	3.432	0.605	0.841	0.590
2 1/2 x 2 1/2	0.105	12	3.141	0.804	0.803	0.643
2 1/2 x 2 1/2	0.135	10	4.006	0.979	1.010	0.783

The 2 3/16" size 10 gauge is shown as 2.19" size on the plans.
The 2 1/2" size is shown as 2.51" size on the plans.

NORTH DAKOTA DEPARTMENT OF TRANSPORTATION	
8-6-09	
REVISIONS	
DATE	CHANGE
7-8-14	Revised Note 3.
8-30-18	Updated notes to active voice.
8-30-19	New Design Engr PE Stamp.
8-05-24	Electronic Stamp/Signature.



08/05/24

SIGN PUNCHING, STRINGER AND SUPPORT LOCATION
DETAILS REGULATORY, WARNING AND GUIDE SIGNS

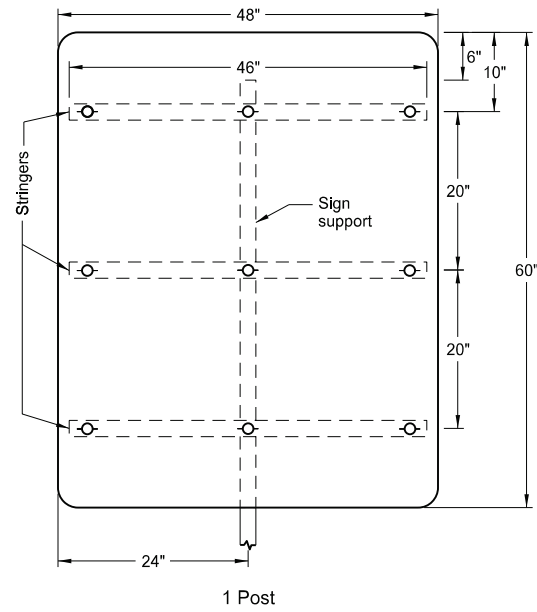

1 Post

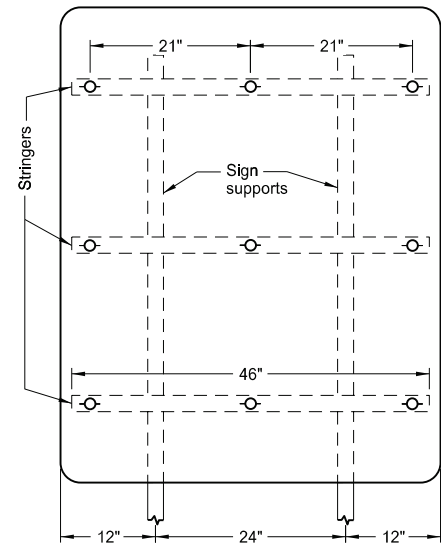

2 Posts

Assembly No. 12

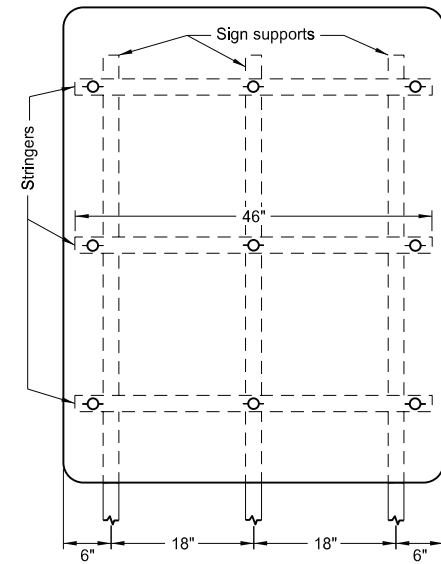

3 Posts

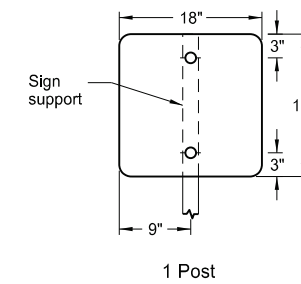

1 Post

Assembly No. 13

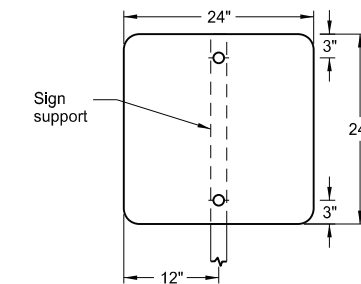

1 Post

Assembly No. 14

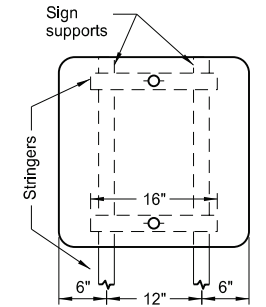

2 Posts

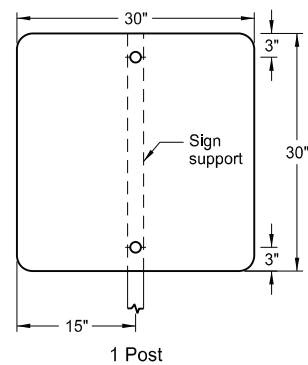

1 Post

Assembly No. 15

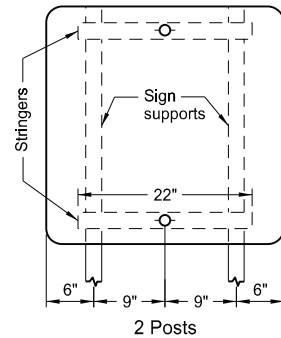

2 Posts

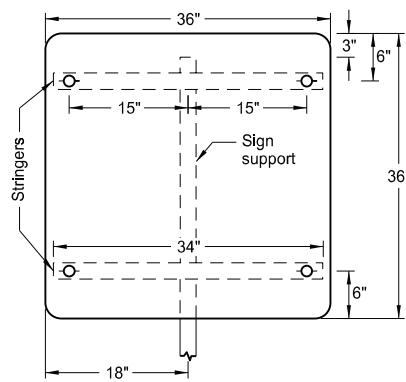

1 Post

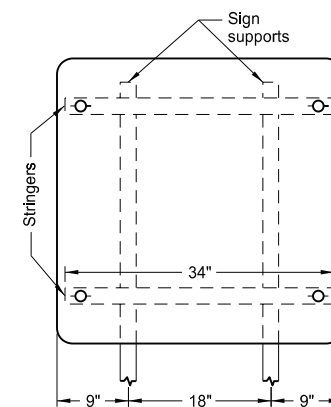

2 Posts

Assembly No. 16

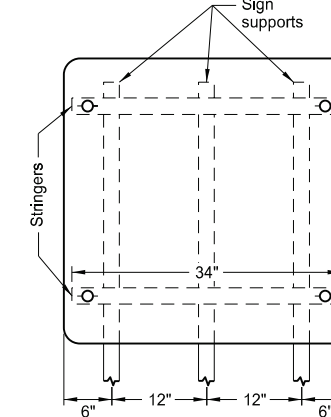

3 Posts

Notes:

1. Use 0.100 inch minimum thickness sign backing material.
2. Use 1 1/2" x 1 1/2" perforated square tube stringers.
3. Punch holes round for 3/8" bolt.

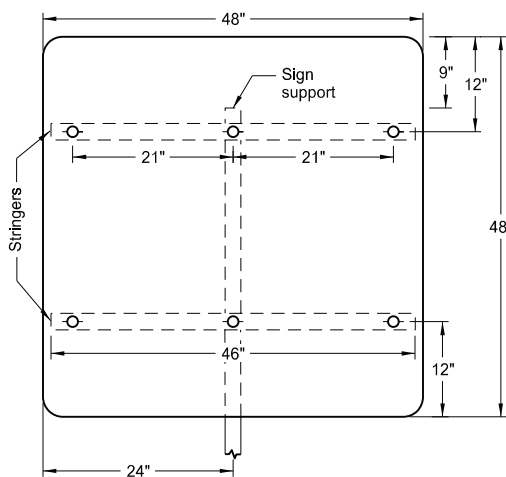

1 Post

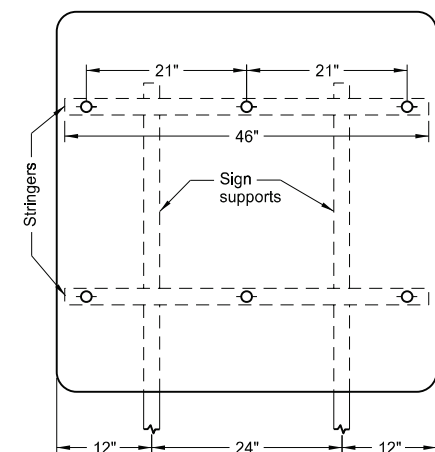

2 Posts

Assembly No. 17

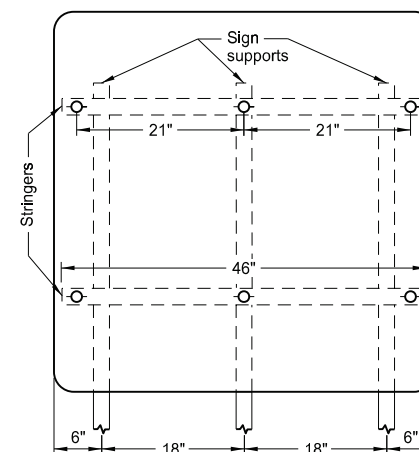

3 Posts

NORTH DAKOTA DEPARTMENT OF TRANSPORTATION	
12-1-10	
REVISIONS	
DATE	CHANGE
8-30-18	Updated to active voice & changed Assembly 16 post spacing.
8-30-19	New Design Engineer PE Stamp.
8-06-24	Electronic Stamp/Signature.



08/06/24

SIGN PUNCHING, STRINGER AND SUPPORT LOCATION
DETAILS REGULATORY, WARNING AND GUIDE SIGNS

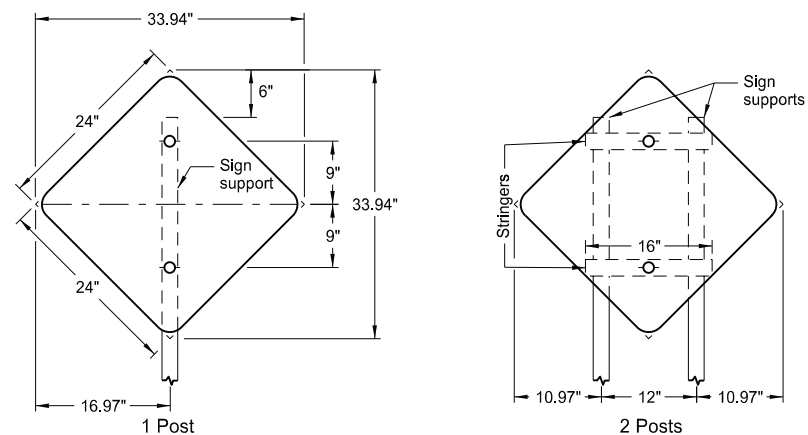

Assembly No. 18

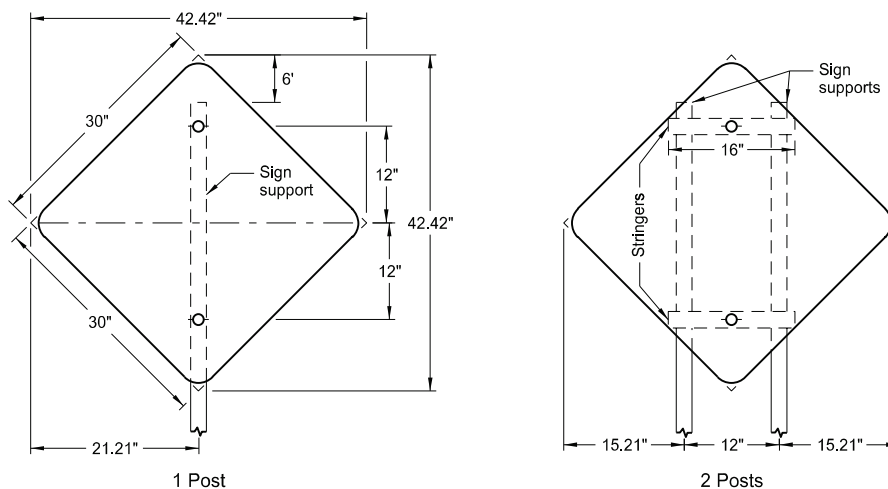

Assembly No. 19

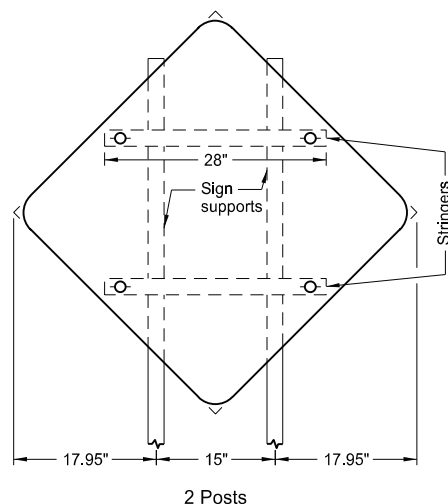
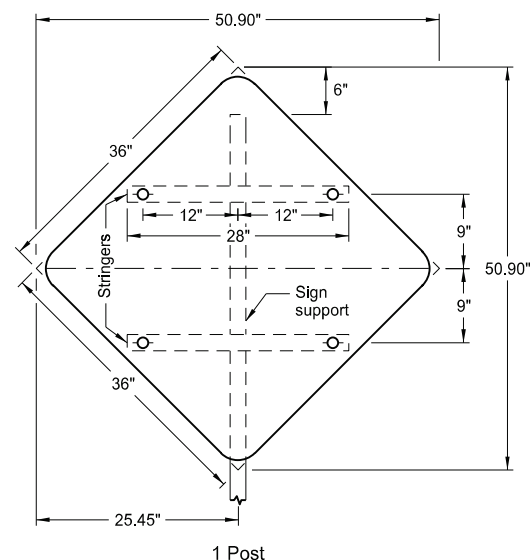

Assembly No. 20

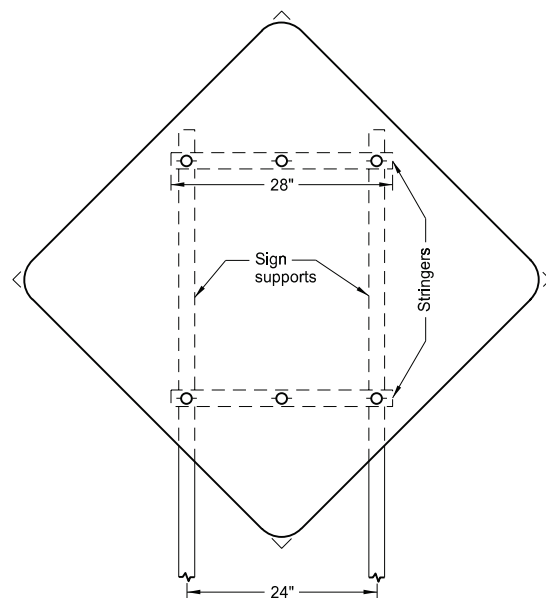
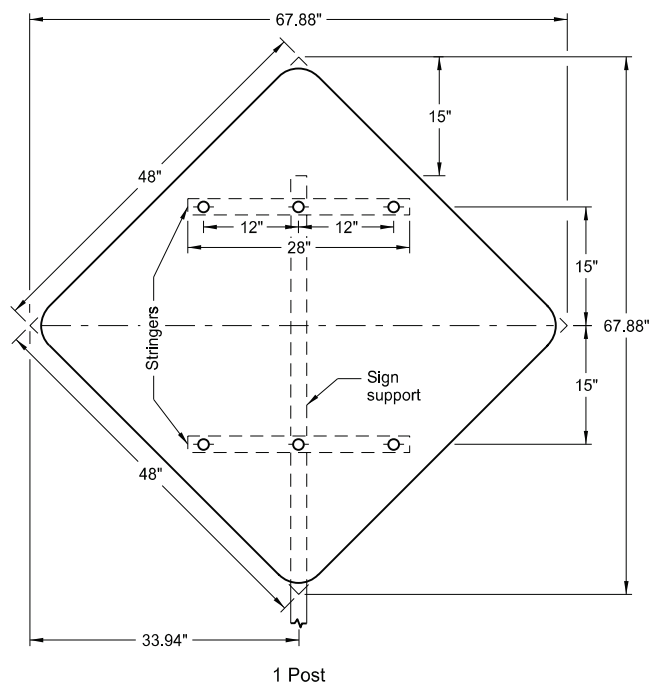
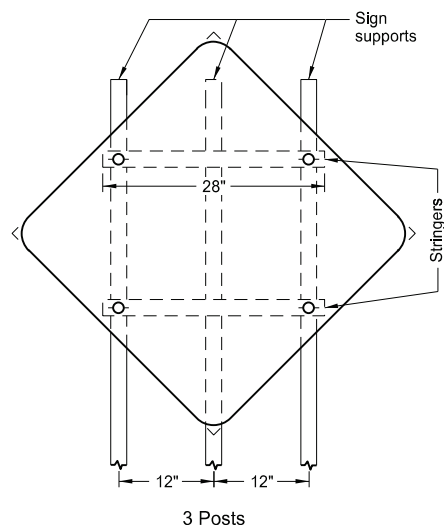

Assembly No. 21

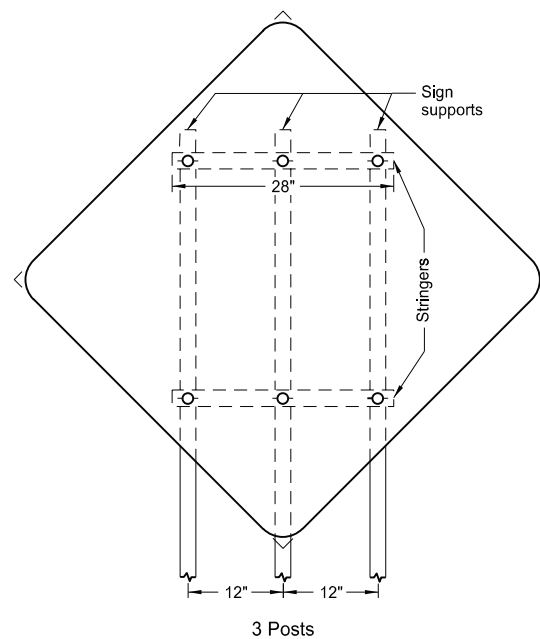

Notes:

1. Use 0.100 inch minimum thickness sign backing material.
2. Use 1½" x 1½" perforated square tube stringers.
3. Punch holes round for ⅜" bolt.

NORTH DAKOTA DEPARTMENT OF TRANSPORTATION	
12-1-10	
REVISIONS	
DATE	CHANGE
8-30-18	Updated notes to active voice.
8-30-19	New Design Engineer PE Stamp.
8-06-24	Electronic Stamp/Signature.

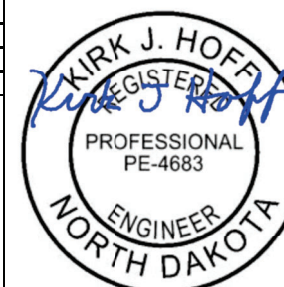

08/06/24

SIGN PUNCHING, STRINGER AND SUPPORT LOCATION
DETAILS REGULATORY, WARNING AND GUIDE SIGNS

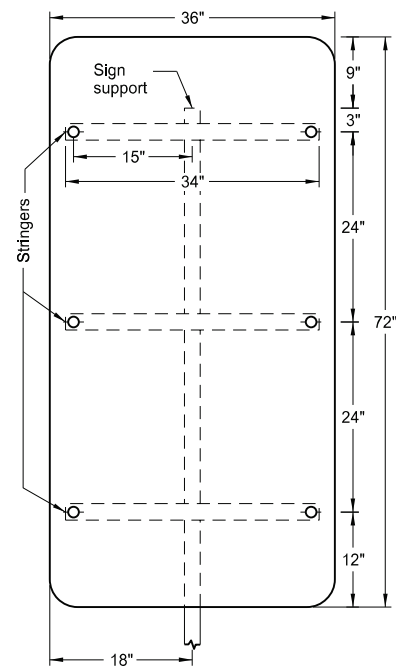

1 Post

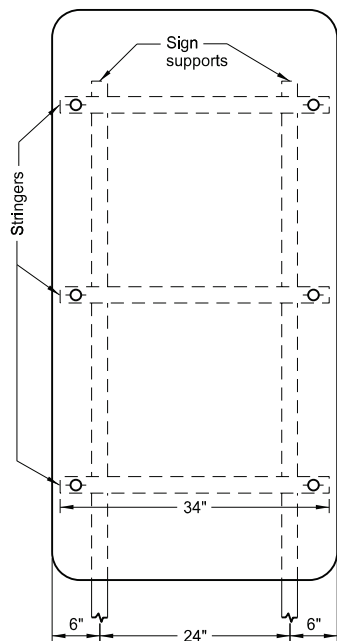

2 Posts

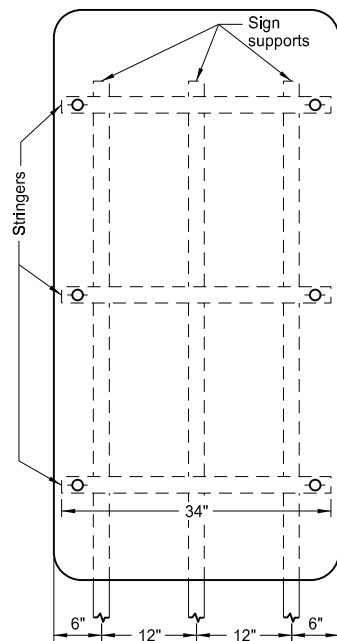

3 Posts

Assembly No. 24

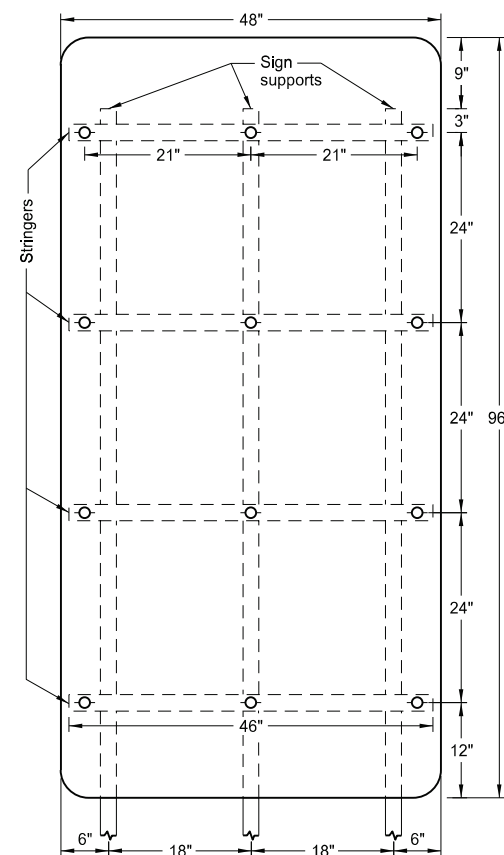

3 Posts

Assembly No. 25

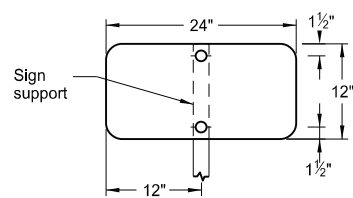

1 Post

Assembly No. 26

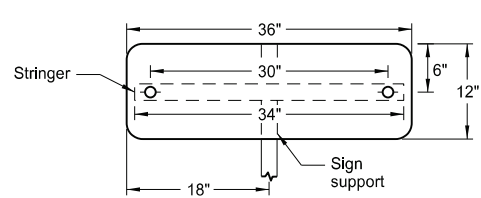

1 Post

Assembly No. 27

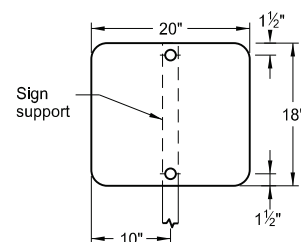

1 Post

Assembly No. 28

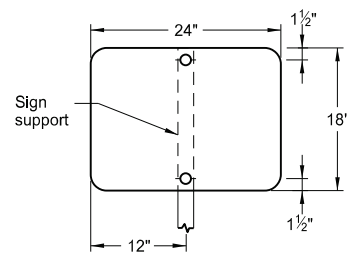

1 Post

Assembly No. 29

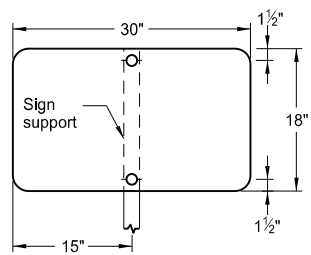

1 Post

Assembly No. 30

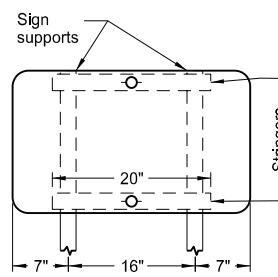

2 Posts

Notes:

1. Use 0.100 inch minimum thickness sign backing material.
2. Use 1 1/2" x 1 1/2" perforated square tube stringers.
3. Punch holes round for 3/8" bolt.

NORTH DAKOTA DEPARTMENT OF TRANSPORTATION	
12-1-10	
REVISIONS	
DATE	CHANGE
8-30-18	Updated notes to active voice.
8-30-19	New Design Engineer PE Stamp.
8-06-24	Electronic Stamp/Signature.

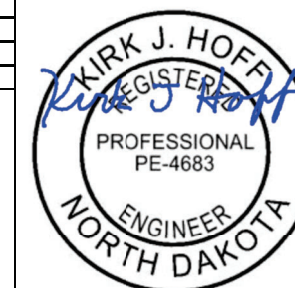

08/06/24

SIGN PUNCHING, STRINGER AND SUPPORT LOCATION DETAILS
REGULATORY, WARNING AND GUIDE SIGNS

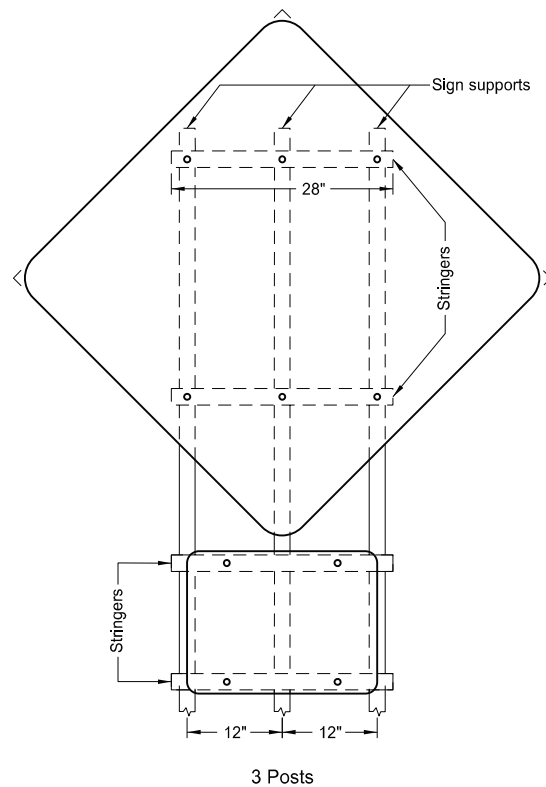
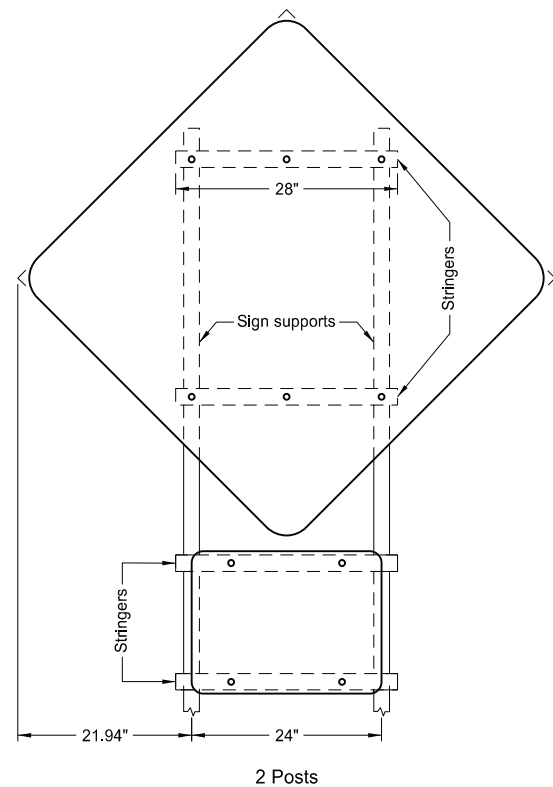
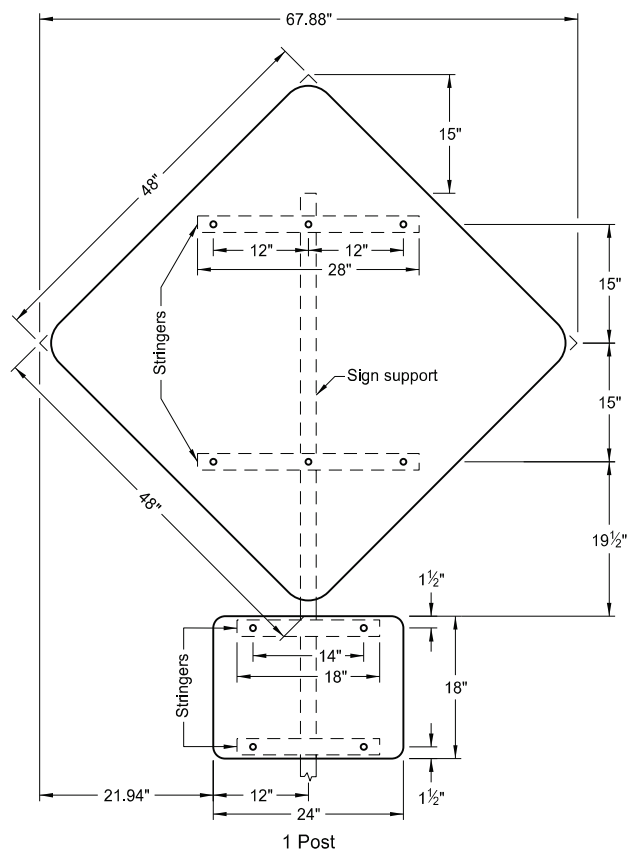

ASSEMBLY NO. 58

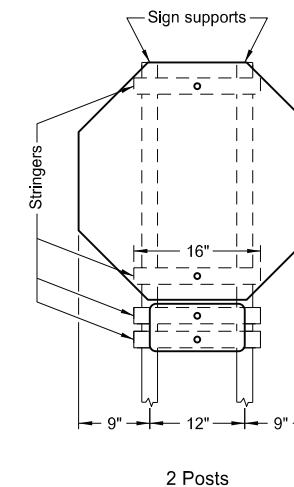
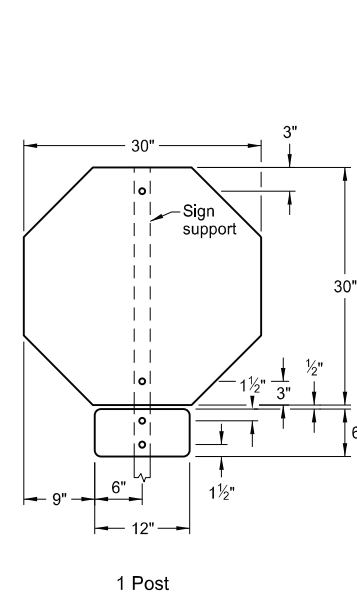

ASSEMBLY NO. 59

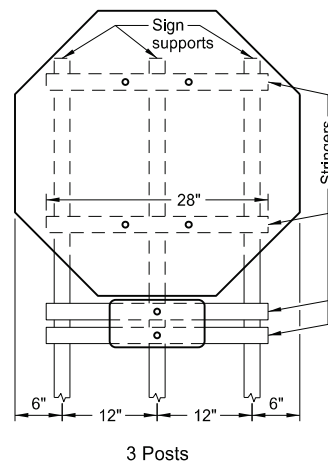
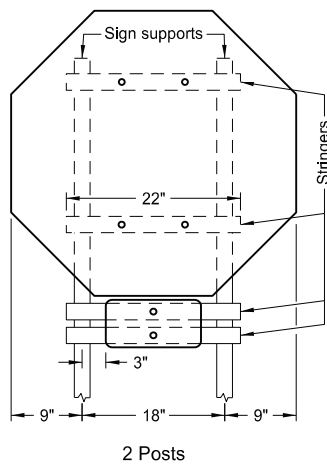
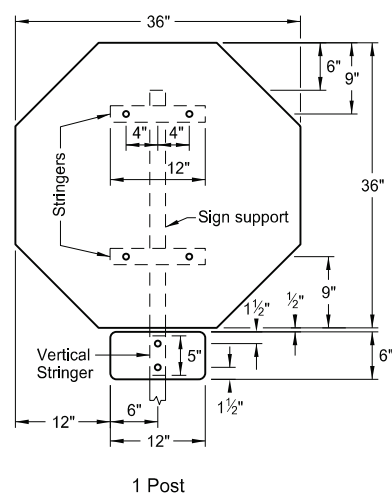

ASSEMBLY NO. 60

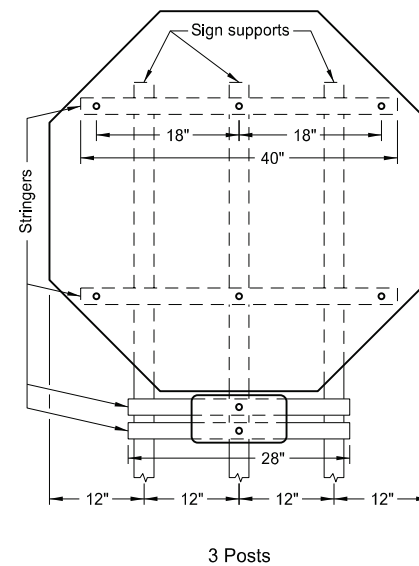
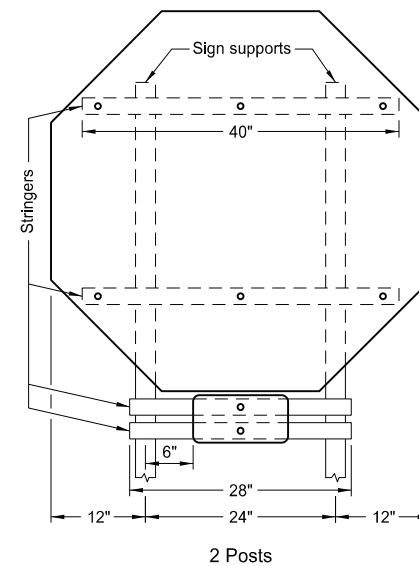
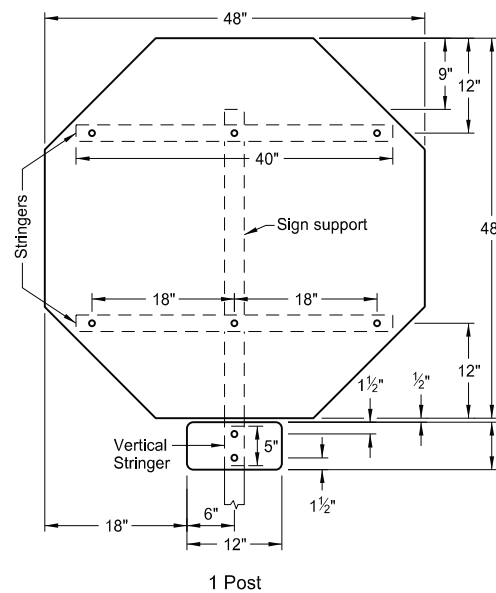

ASSEMBLY NO. 61

Notes:

1. Use 0.100 inch minimum thickness sign backing material.
2. Use 1 1/2"x1 1/2" perforated square tube stringers.
3. Punch holes round for 3/8" bolt.

NORTH DAKOTA DEPARTMENT OF TRANSPORTATION	
8-22-12	
REVISIONS	
DATE	CHANGE
8-30-18	Updated to active voice & added Assembly 58 dimension.
8-30-19	New Design Engineer PE Stamp.
8-06-24	Electronic Stamp/Signature.



08/06/24

PUNCHING, STRINGER, AND SUPPORT LOCATION DETAILS FOR REGULATORY, WARNING AND GUIDE BIKE ROUTE SIGNS

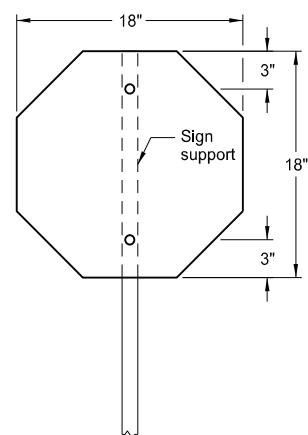

1 Post
Assembly No. 100

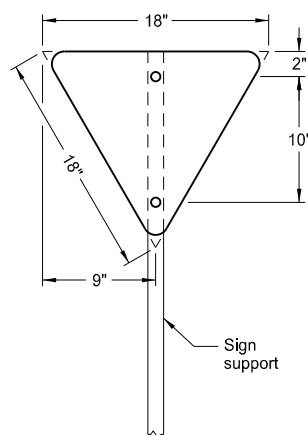

1 Post
Assembly No. 101

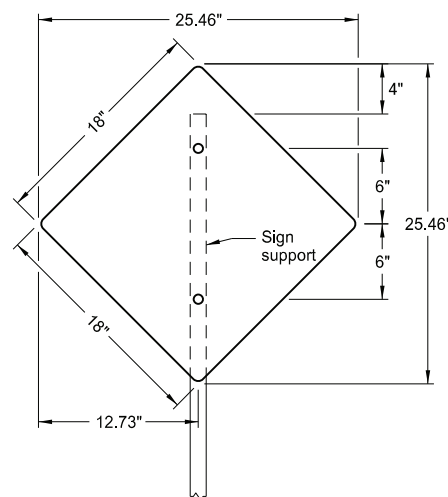

1 Post
Assembly No. 102

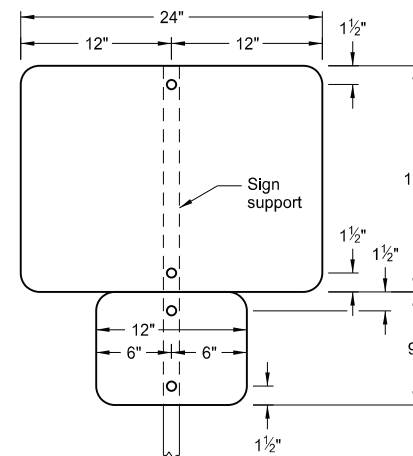

1 Post
Assembly No. 103

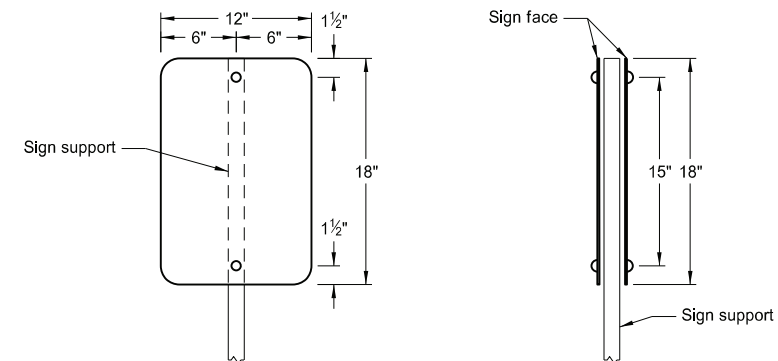

1 Post
back to back
Assembly No. 104

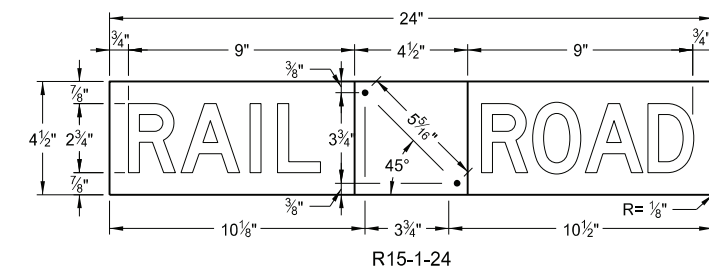

R15-1-24

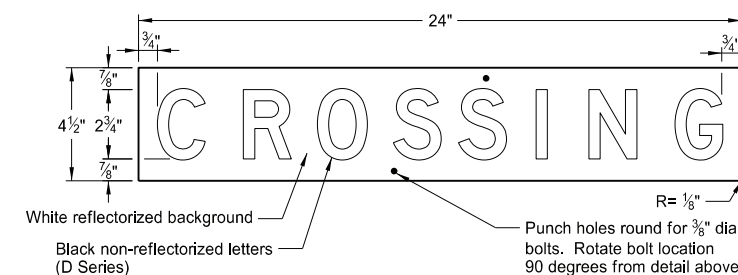

White reflectorized background
Black non-reflectorized letters
Punch holes round for 3/8" dia bolts. Rotate bolt location 90 degrees from detail above.

R15-1-24

Railroad Crossing Sign Details

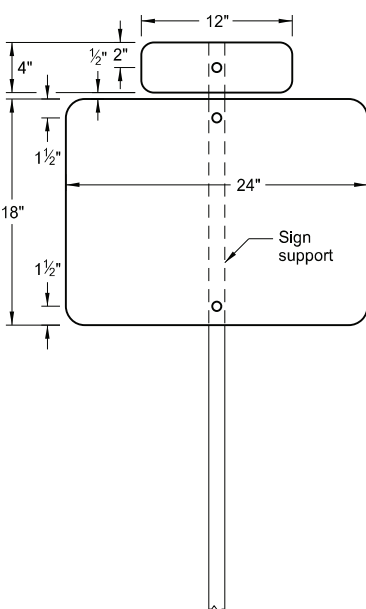
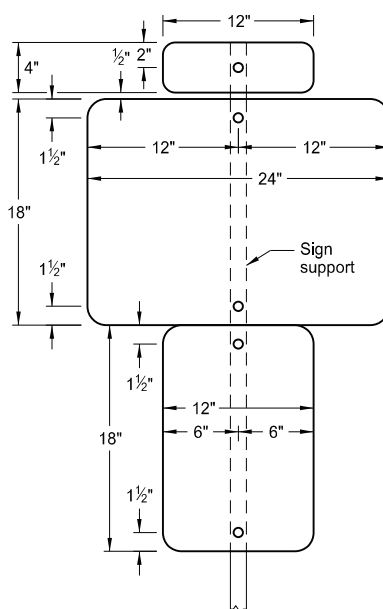

1 Post
back to back
Assembly No. 105

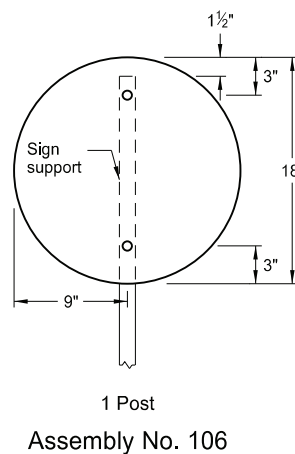
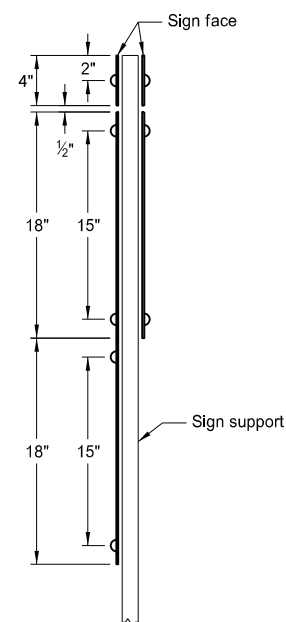

1 Post
Assembly No. 106

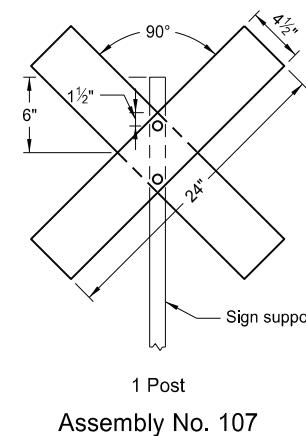

1 Post
Assembly No. 107

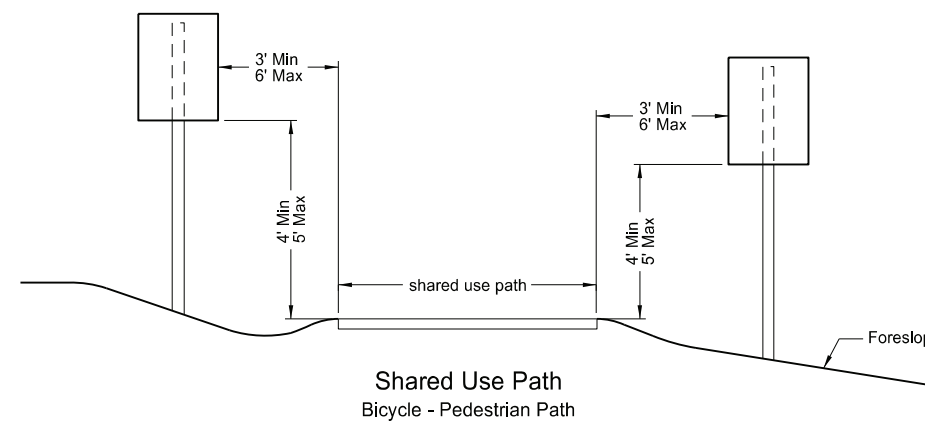

- Notes:
1. Use 0.100 inch minimum thickness sign backing material.
 2. Punch holes round for 3/8" bolt.

NORTH DAKOTA DEPARTMENT OF TRANSPORTATION	
8-22-12	
REVISIONS	
DATE	CHANGE
9-18-15	Revised Title Name.
8-30-18	Updated notes to active voice.
9-04-19	New Design Engineer PE Stamp.
8-07-24	Electronic Stamp/Signature.

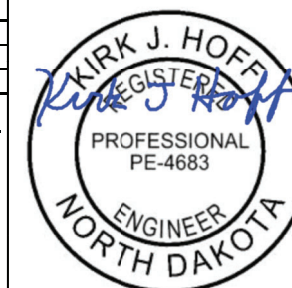

08/07/24

SIGN PUNCHING, STRINGER AND SUPPORT LOCATION DETAILS FOR VARIABLE LENGTH SIGNS

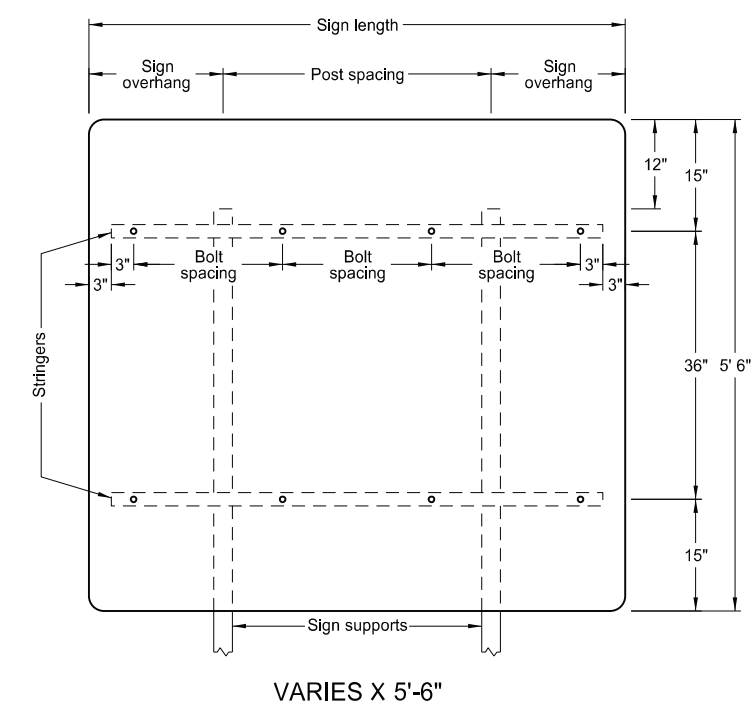
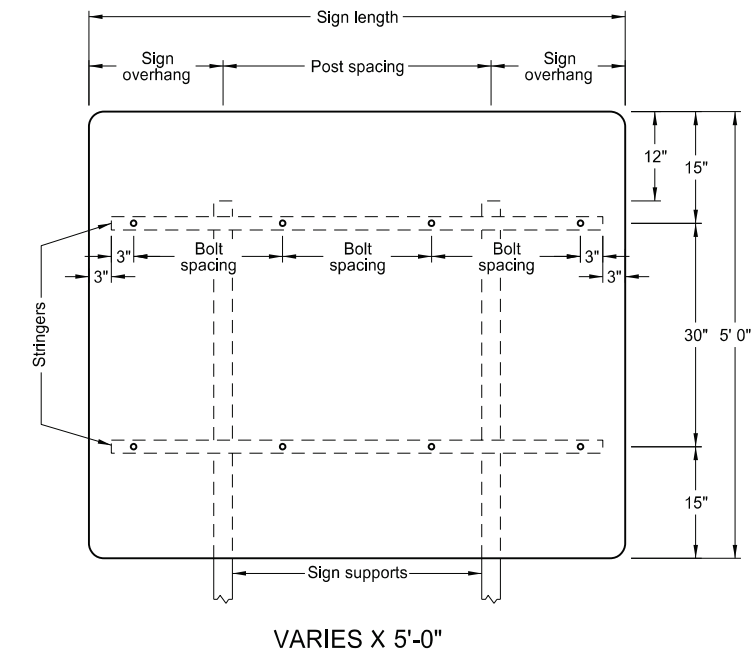
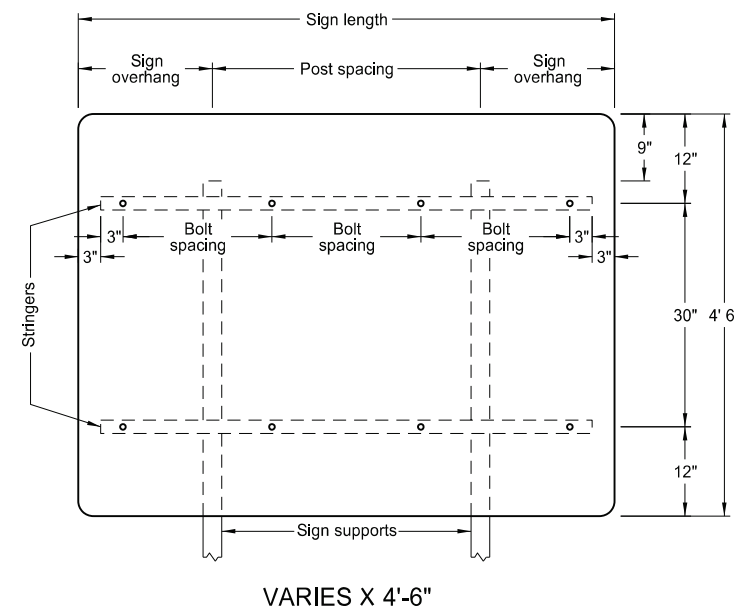
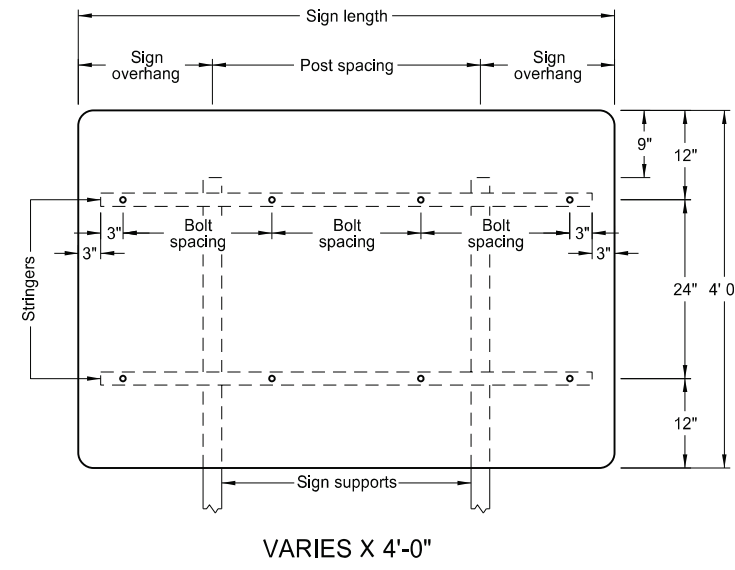
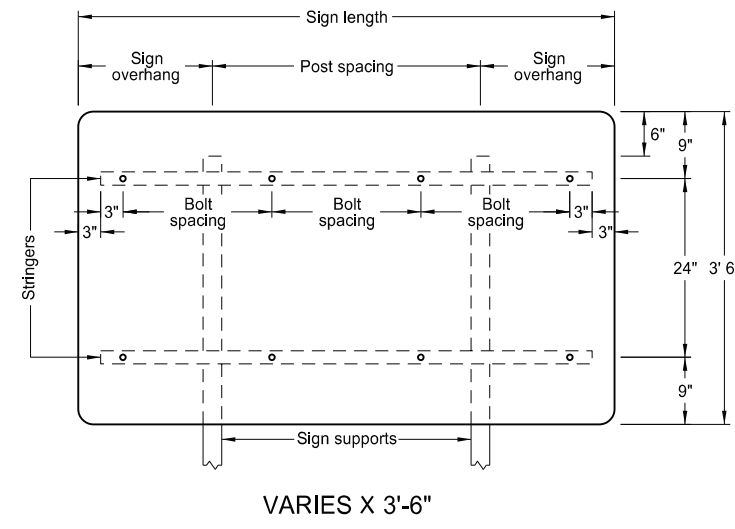
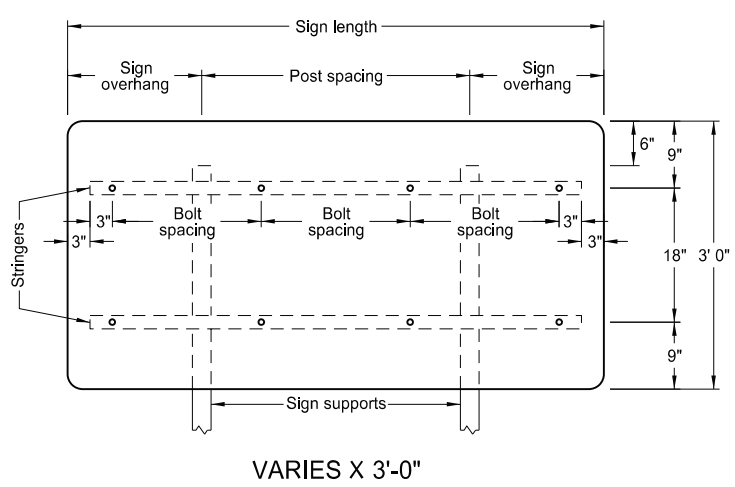
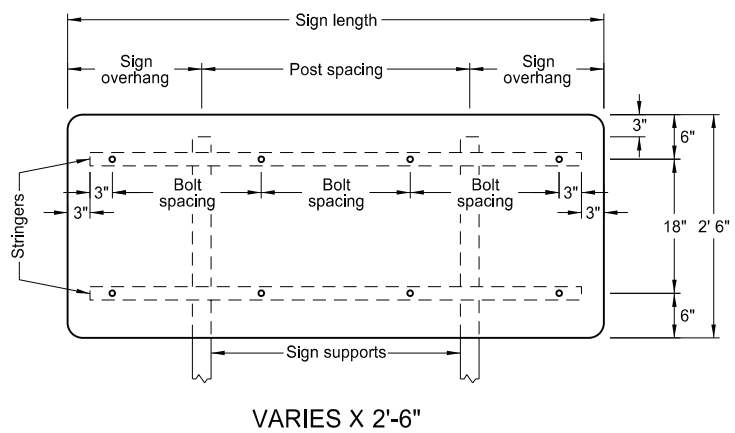
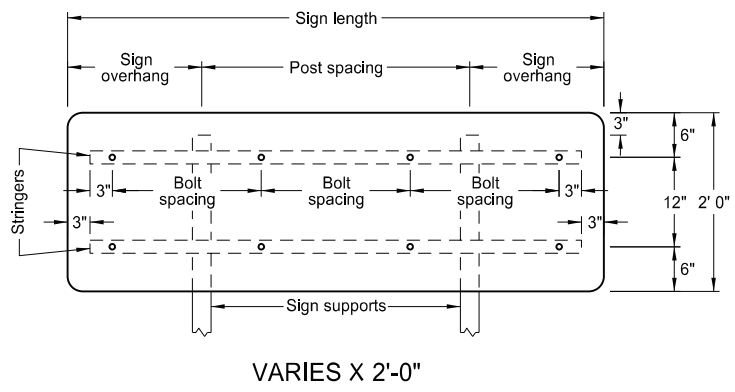
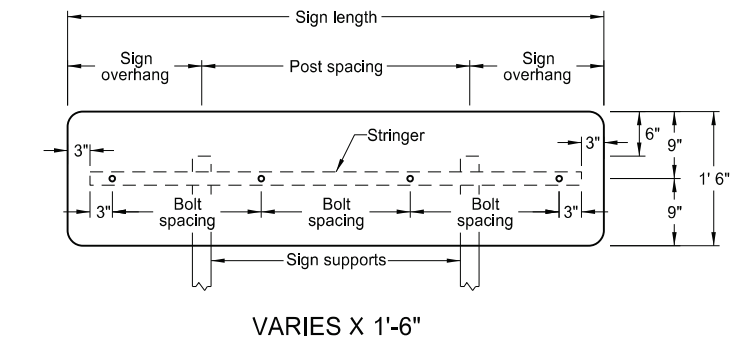

2 POSTS			
Sign Length	Sign Overhang	Post Spacing	Bolt Spacing
4'-0"	1'-0"	2'-0"	18"
4'-6"	1'-3"	2'-0"	21"
5'-0"	1'-0"	3'-0"	24"
5'-6"	1'-3"	3'-0"	18"
6'-0"	1'-6"	3'-0"	20"
6'-6"	1'-3"	4'-0"	22"
7'-0"	1'-6"	4'-0"	24"
7'-6"	1'-9"	4'-0"	2-20" & 2-19"
8'-0"	2'-0"	4'-0"	21"
8'-6"	1'-9"	5'-0"	2-22" & 2-23"
9'-0"	2'-0"	5'-0"	24"
9'-6"	1'-9"	6'-0"	4-20" & 1-22"
10'-0"	2'-0"	6'-0"	2-21" & 3-22"
10'-6"	2'-3"	6'-0"	4-23" & 1-22"
11'-0"	2'-6"	6'-0"	24"
11'-6"	2'-9"	6'-0"	21"
12'-0"	2'-0"	8'-0"	22"
12'-6"	2'-3"	8'-0"	23"
13'-0"	2'-6"	8'-0"	24"
13'-6"	2'-9"	8'-0"	3-22" & 4-21"
14'-0"	3'-0"	8'-0"	2-23" & 5-22"
14'-6"	3'-3"	8'-0"	6-23" & 1-24"
15'-0"	3'-6"	8'-0"	24"
15'-6"	2'-9"	10'-0"	6-22" & 2-21"
16'-0"	3'-0"	10'-0"	4-23" & 4-22"
16'-6"	3'-3"	10'-0"	6-23" & 2-24"
17'-0"	3'-6"	10'-0"	24"
17'-6"	3'-9"	10'-0"	22"
18'-0"	3'-0"	12'-0"	6-23" & 3-22"
18'-6"	3'-3"	12'-0"	6-23" & 3-24"
19'-0"	3'-6"	12'-0"	24"
19'-6"	3'-9"	12'-0"	8-22" & 2-23"
20'-0"	4'-0"	12'-0"	8-23" & 2-22"

- Notes:
- Use 0.100 inch minimum thickness sign backing material.
 - Use 1 1/2" x 1 1/2" perforated square tube stringers.
 - Punch holes round for 3/8" bolt.

NORTH DAKOTA DEPARTMENT OF TRANSPORTATION	
9-25-12	
REVISIONS	
DATE	CHANGE
8-30-18	Updated notes to active voices.
9-04-19	New Design Engineer PE Stamp.
8-07-24	Electronic Stamp/Signature.

KIRK J. HOFF
REGISTERED
PROFESSIONAL
PE-4683
ENGINEER
NORTH DAKOTA
08/07/24

SIGN PUNCHING, STRINGER AND SUPPORT LOCATION DETAILS FOR VARIABLE LENGTH SIGNS

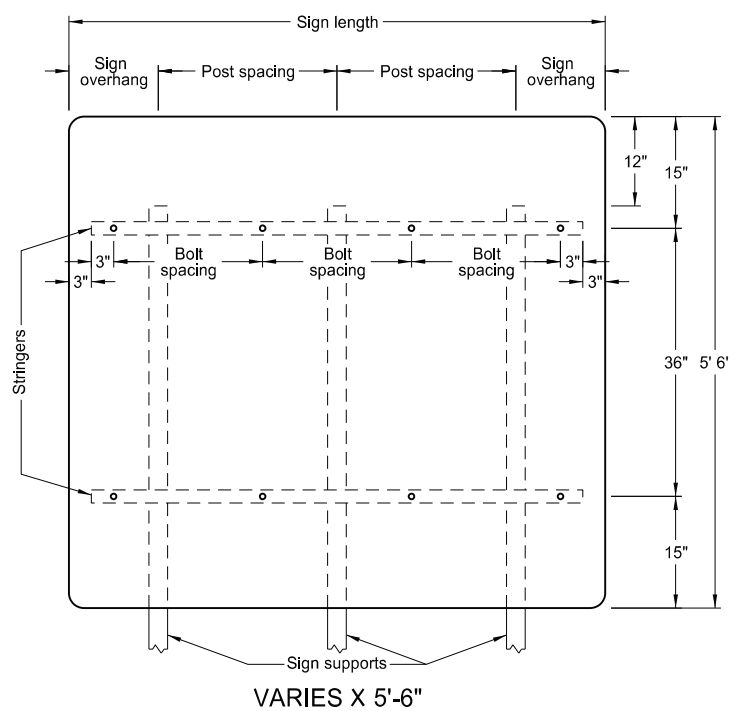
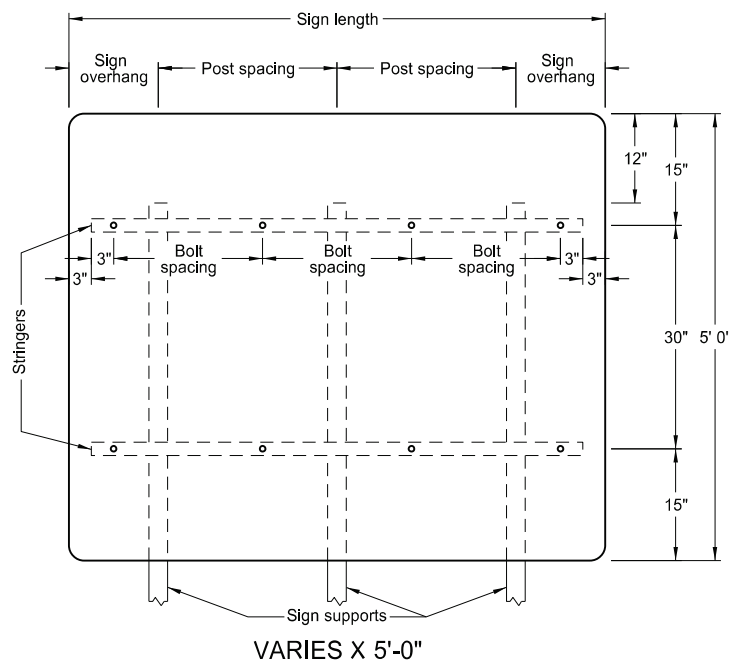
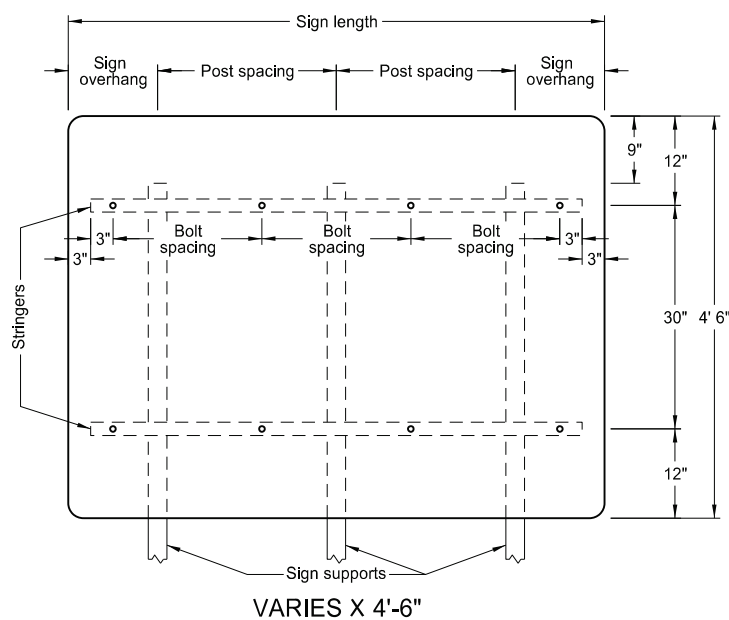
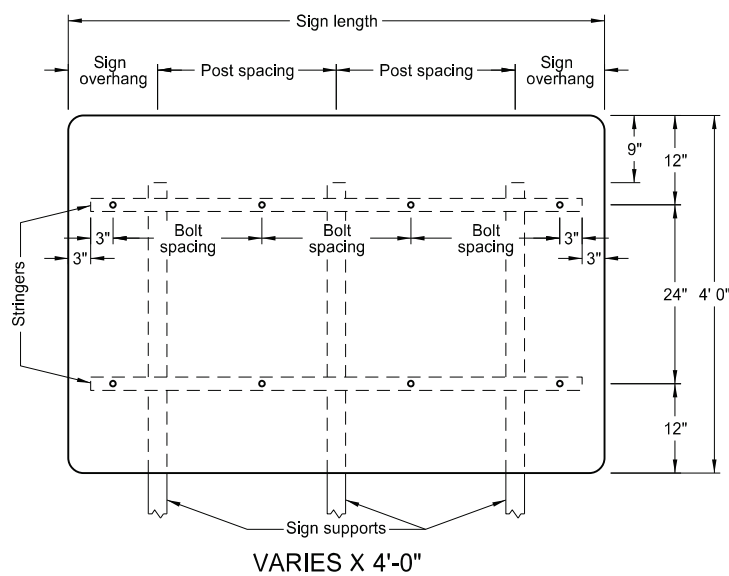
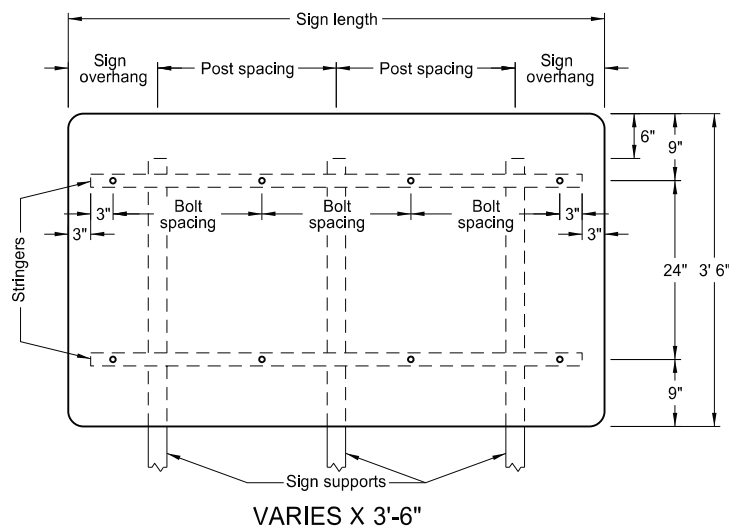
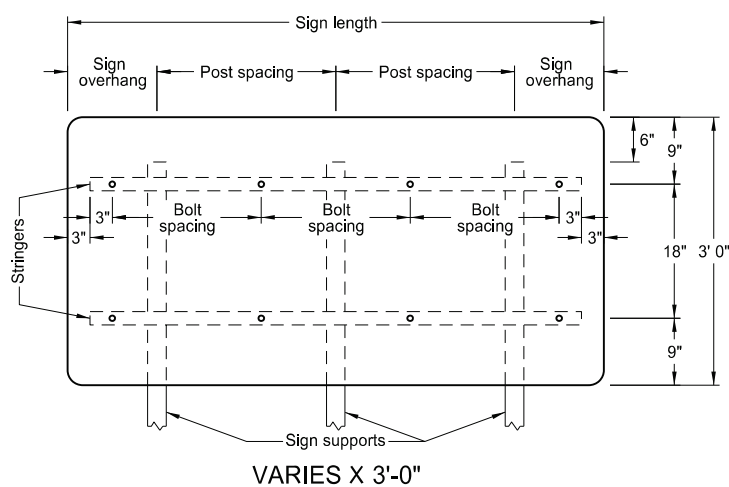
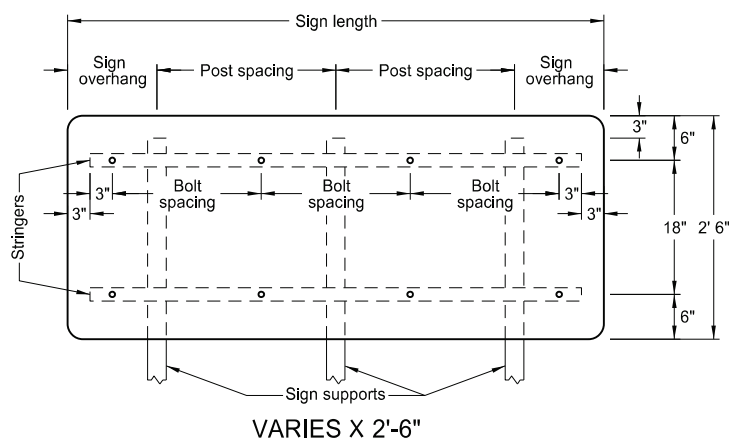
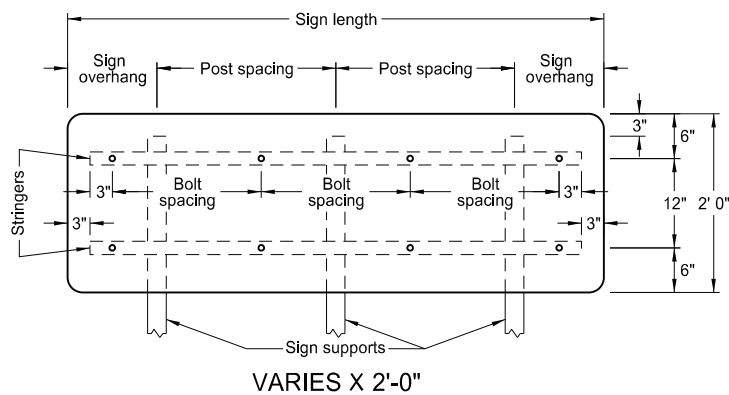
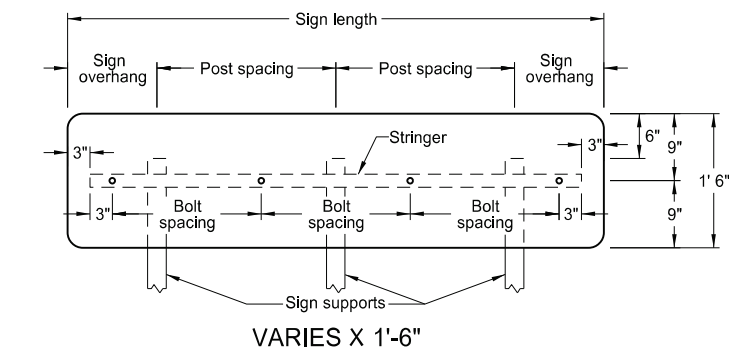

3 POSTS			
Sign Length	Sign Overhang	Post Spacing	Bolt Spacing
4'-0"	0'-6"	1'-6"	18"
4'-6"	0'-6"	1'-9"	21"
5'-0"	0'-6"	2'-0"	24"
5'-6"	1'-3"	1'-6"	18"
6'-0"	1'-0"	2'-0"	20"
6'-6"	1'-3"	2'-0"	22"
7'-0"	1'-6"	2'-0"	24"
7'-6"	1'-6"	2'-3"	2-20" & 2-19"
8'-0"	1'-9"	2'-3"	21"
8'-6"	2'-0"	2'-3"	2-22" & 2-23"
9'-0"	1'-6"	3'-0"	24"
9'-6"	1'-9"	3'-0"	4-20" & 1-22"
10'-0"	1'-9"	3'-3"	2-21" & 3-22"
10'-6"	1'-9"	3'-6"	4-23" & 1-22"
11'-0"	2'-0"	3'-6"	24"
11'-6"	2'-3"	3'-6"	21"
12'-0"	2'-4"	3'-8"	22"
12'-6"	2'-5"	3'-10"	23"
13'-0"	2'-6"	4'-0"	24"
13'-6"	2'-9"	4'-0"	3-22" & 4-21"
14'-0"	3'-0"	4'-0"	2-23" & 5-22"
14'-6"	3'-3"	4'-0"	6-23" & 1-24"
15'-0"	3'-6"	4'-0"	24"
15'-6"	2'-4"	5'-5"	6-22" & 2-21"
16'-0"	2'-5"	5'-7"	4-23" & 4-22"
16'-6"	2'-5"	5'-10"	6-23" & 2-24"
17'-0"	2'-6"	6'-0"	24"
17'-6"	3'-3"	5'-6"	22"
18'-0"	3'-6"	5'-6"	6-23" & 3-22"
18'-6"	3'-9"	5'-6"	6-23" & 3-24"
19'-0"	3'-6"	6'-0"	24"
19'-6"	4'-3"	5'-6"	8-22" & 2-23"
20'-0"	4'-4"	5'-8"	8-23" & 2-22"

- Notes:
1. Use 0.100 minimum thickness sign backing material.
 2. Use 1 1/2" x 1 1/2" perforated square tube stringers.
 3. Punch holes round for 3/8" bolt.

NORTH DAKOTA DEPARTMENT OF TRANSPORTATION	
9-25-12	
REVISIONS	
DATE	CHANGE
8-30-18	Updated notes to active voice.
9-04-19	New Design Engineer PE Stamp.
8-07-24	Electronic Stamp/Signature.

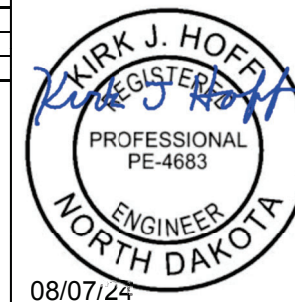

08/07/24

SIGN PUNCHING, STRINGER AND SUPPORT LOCATION DETAILS - ROUTE MARKER SIGNS

D-754-53

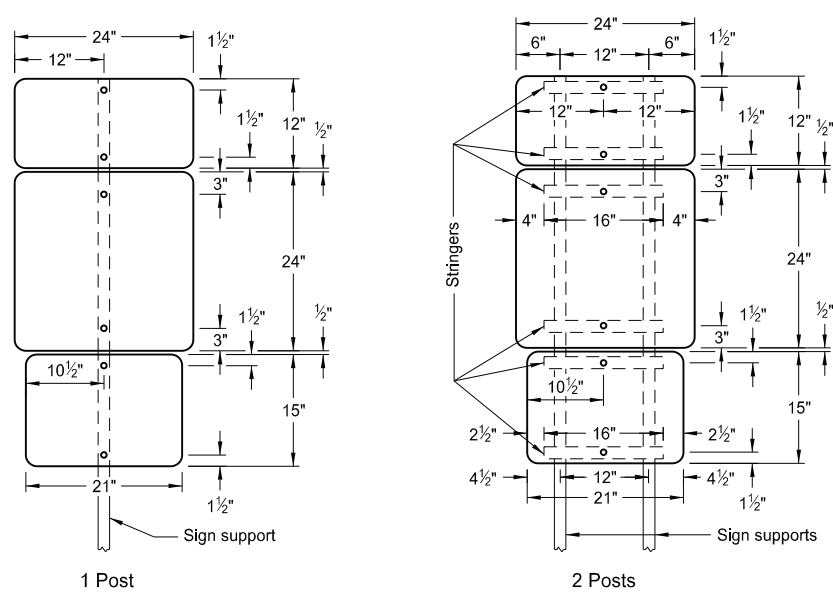

ASSEMBLY NO. 379

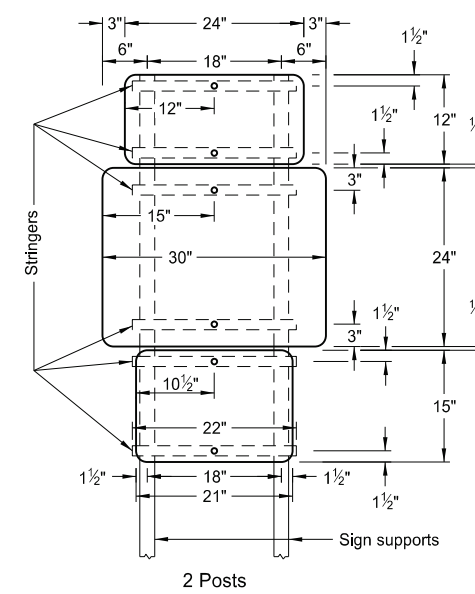
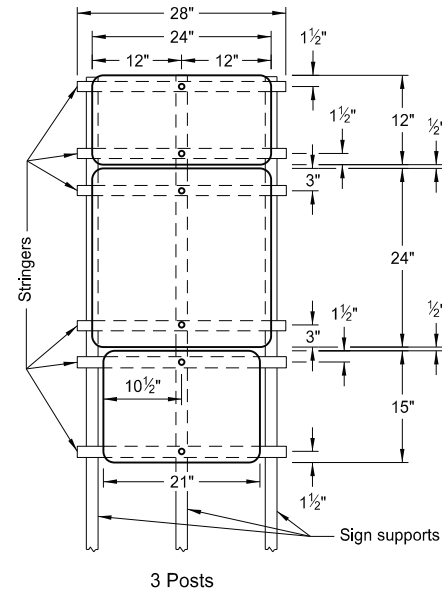

ASSEMBLY NO. 380

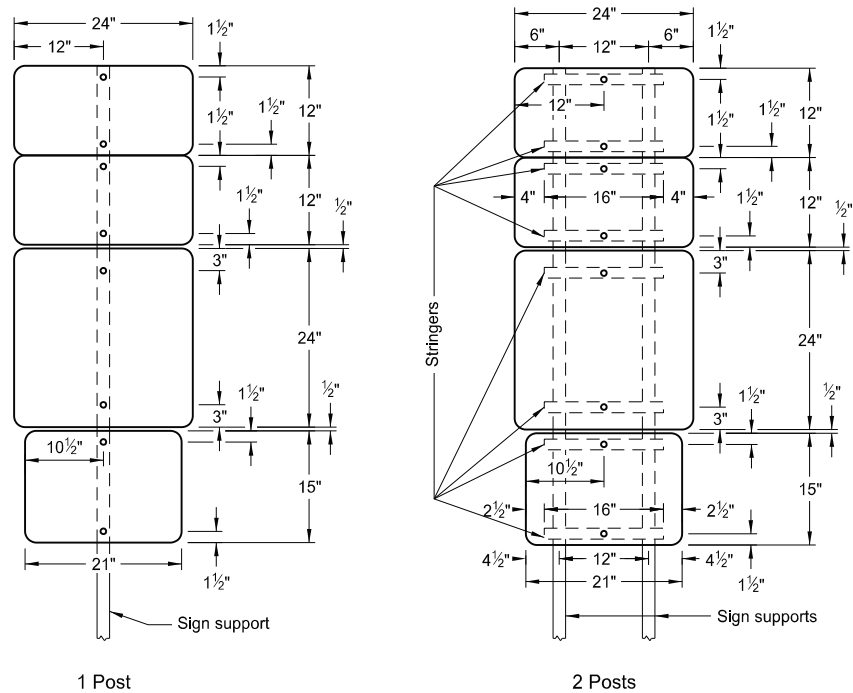
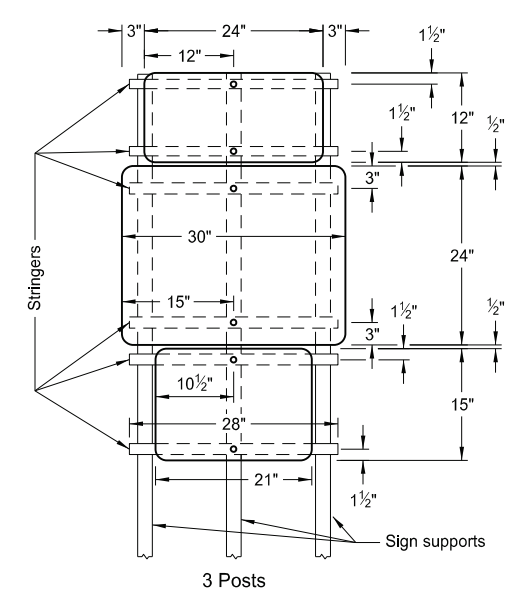

ASSEMBLY NO. 381

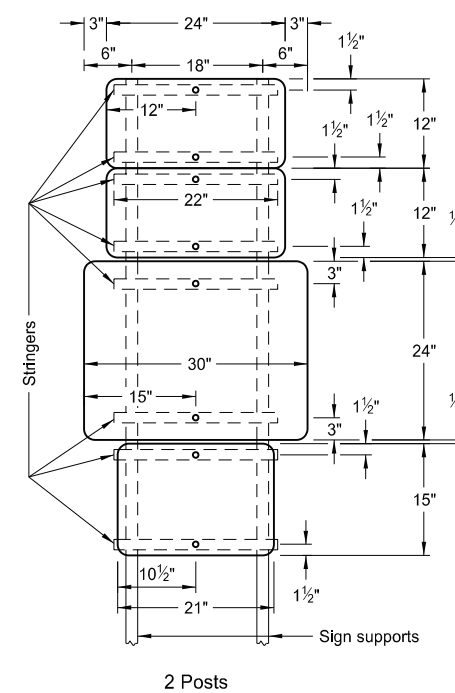
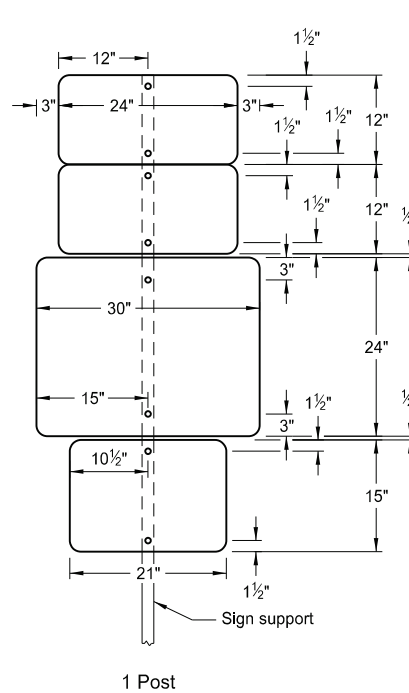
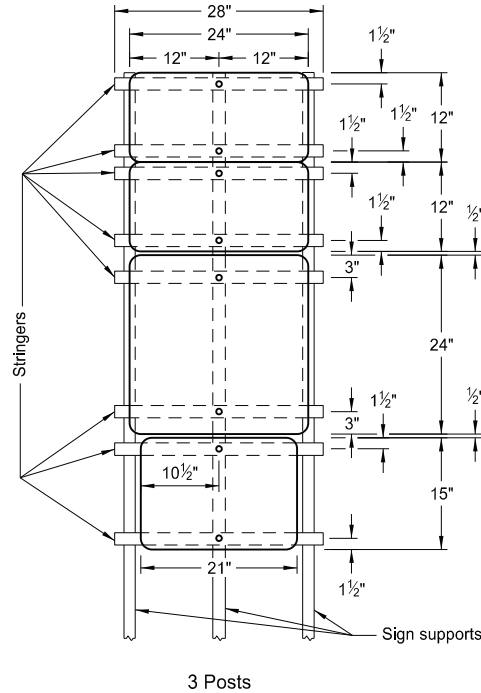

ASSEMBLY NO. 382

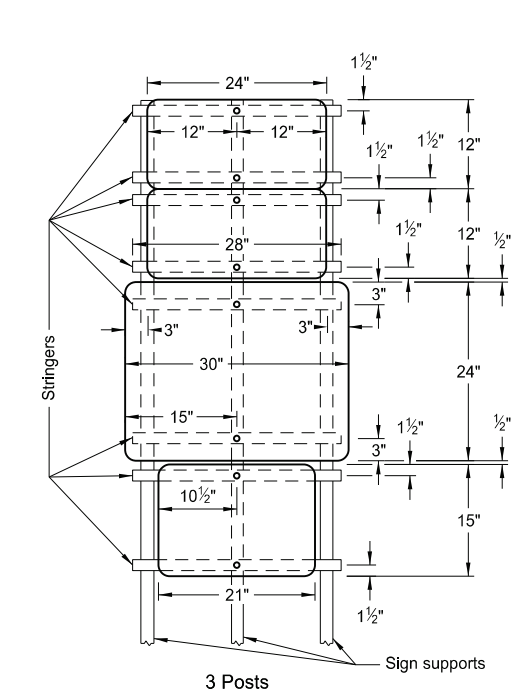

Notes:

1. Use 0.100 inch minimum thickness sign backing material.
2. Use 1 1/2"x1 1/2" perforated square tube stringers.
3. Punch holes round for 3/8" bolt.

NORTH DAKOTA DEPARTMENT OF TRANSPORTATION	
8-22-12	
REVISIONS	
DATE	CHANGE
8-30-18	Updated notes to active voice.
9-04-19	New Design Engineer PE Stamp.
8-07-24	Electronic Stamp/Signature.



08/07/24

SIGN PUNCHING, STRINGER AND SUPPORT LOCATION DETAILS - ROUTE MARKER SIGNS

D-754-58

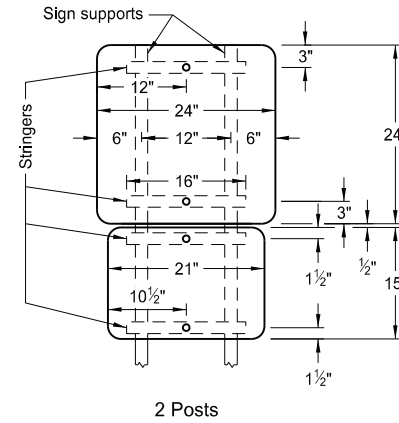
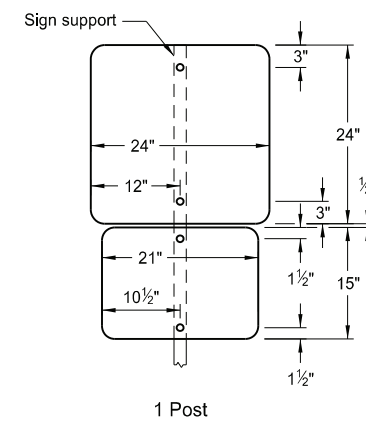
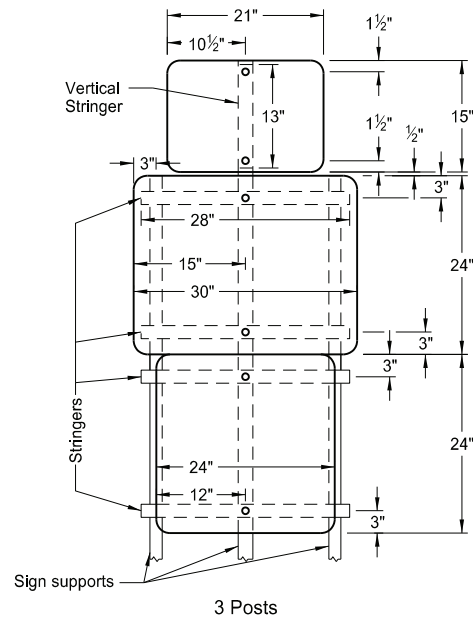
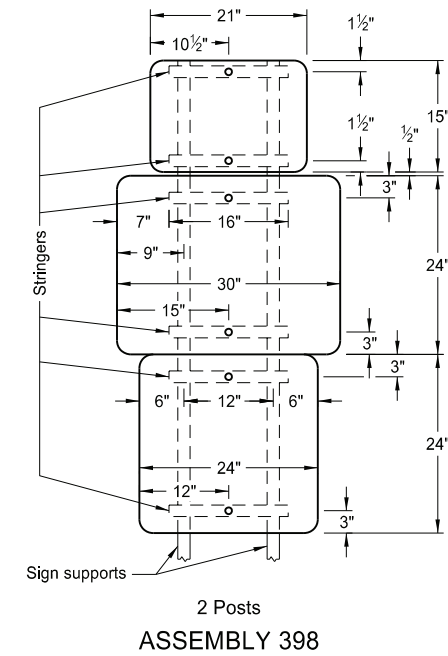
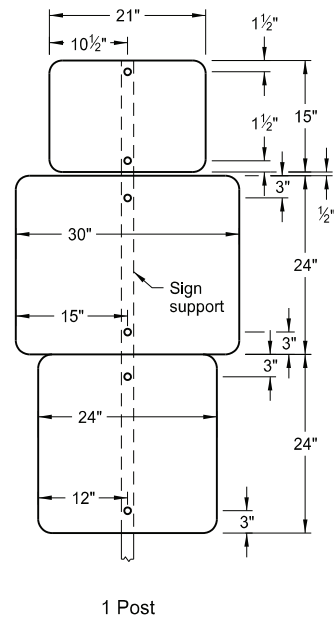
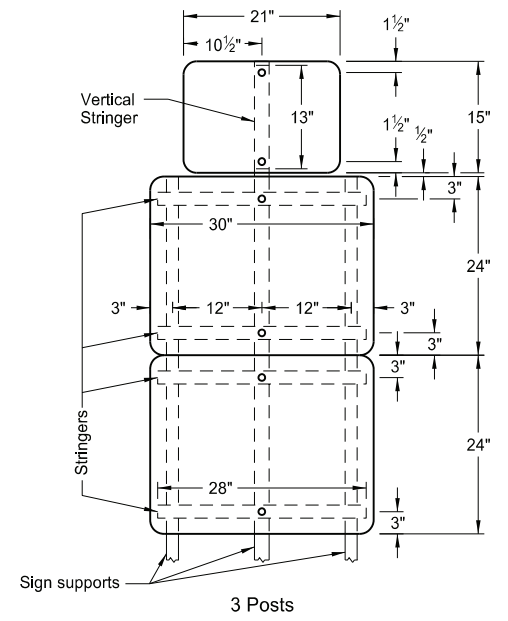
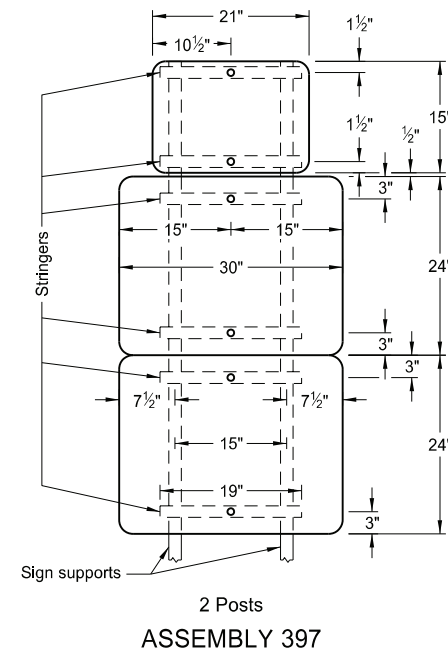
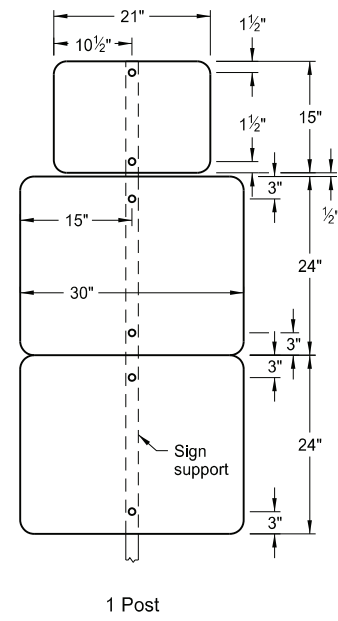
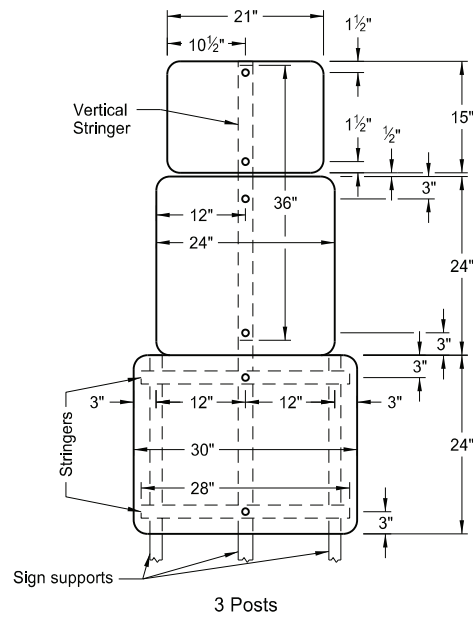
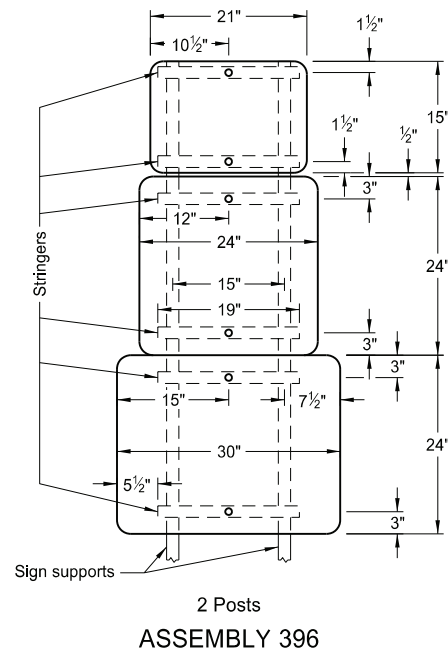
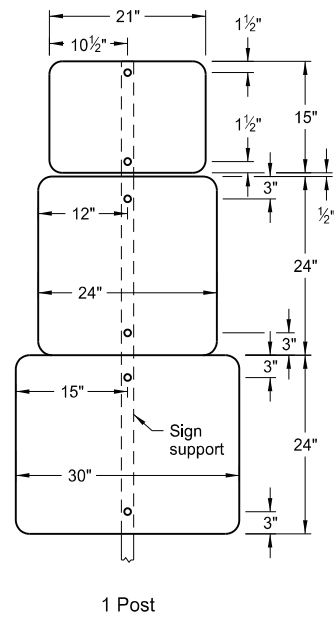

- Notes:
1. Use 0.100 inch minimum thickness sign backing material.
 2. Use 1 1/2"x1 1/2" perforated square tube stringers.
 3. Punch holes round for 3/8" bolt.

NORTH DAKOTA DEPARTMENT OF TRANSPORTATION	
8-22-12	
REVISIONS	
DATE	CHANGE
8-30-18	Updated to active voice & added Assembly 398 dimension.
9-04-19	New Design Engineer PE Stamp.
8-07-24	Electronic Stamp/Signature.



08/07/24

OBJECT MARKERS - CULVERTS

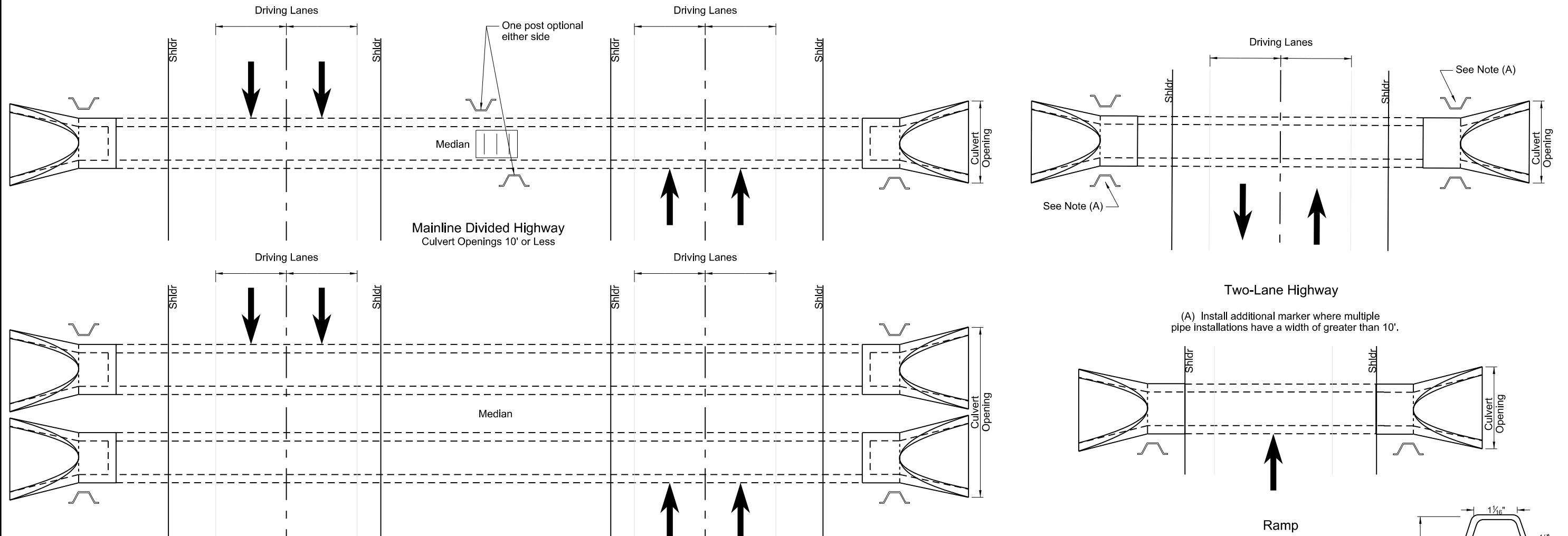

Post Location

Mainline Divided Highway
Culvert Openings Greater than 10'
Multiple Installations

Notes:

Mark each end of culverts crossing the roadway within the right-of-way with a post. Install posts in front of culvert in direction of travel along the side of culvert and one foot from culvert opening unless shown otherwise in plans.

Top 12 inches painted black

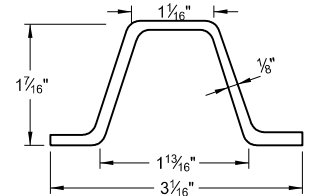
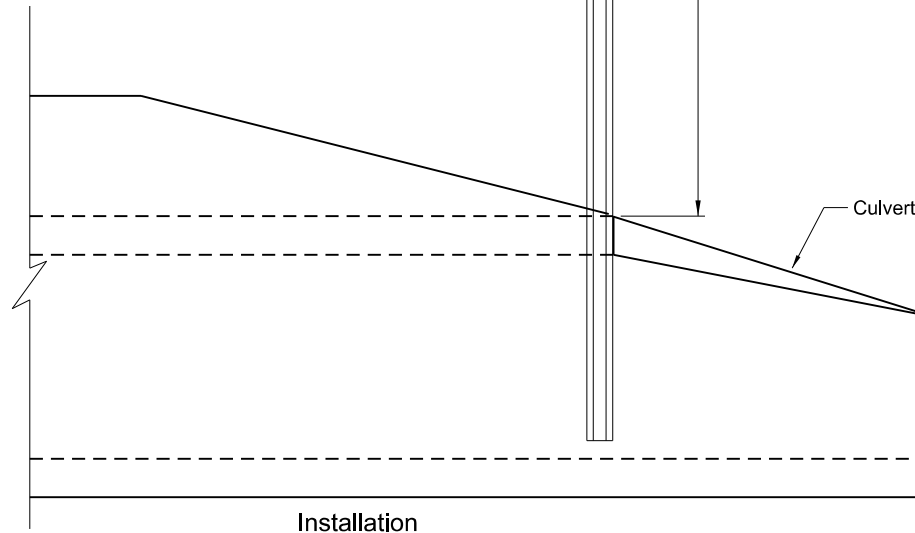

Steel Post Detail
Approx. 2.0 lbs/ft

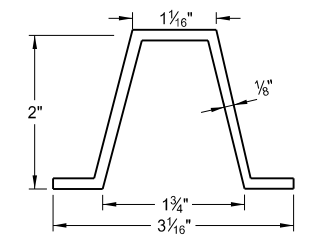

Aluminum Post Detail
Approx. 0.88 lbs/ft

NORTH DAKOTA DEPARTMENT OF TRANSPORTATION	
8-05-13	
REVISIONS	
DATE	CHANGE
7-7-14	Revised Notes
8-30-18	Updated notes to active voice.
9-05-19	New Design Engineer PE Stamp.

This document was originally issued and sealed by Kirk J Hoff, Registration Number PE- 4683, on 9/05/19 and the original document is stored at the North Dakota Department of Transportation

911 SIGN SUPPORT INFORMATION AND SIGN DETAILS

D-754-86

POST INFORMATION FOR VARIOUS SIGN CONFIGURATIONS													
ASSEMBLY NUMBER	STREET NAME SIGN SIZE	VERTICAL CLEARANCE	MAXIMUM POST LENGTH	NUMBER OF POSTS	SUPPORT SIZE	SLEEVE LENGTH (A)			SLEEVE SIZE	ANCHOR			BREAKAWAY
						1st	2nd	3rd		NUMBER	LENGTH	SIZE	
						LF	LF	LF					
Special Assembly 1	48"x15"	7	14.5	1	2.5 x 2.5 12 ga					1	4.0	3 x 3 7 ga	
	54"x15"	7	16.1	1	2.5 x 2.5 12 ga					1	4.0	3 x 3 7 ga	
	60"x15"	7	18.9	1	2.25 x 2.25 12 ga	2.6			2 x 2 12 ga	1	4.0	3 x 3 7 ga	1
	66"x15"	7	15.8	1	2.5 x 2.5 10 ga					1	4.0	3 x 3 7 ga	1
	72"x15"	7	14.6	1	2.5 x 2.5 10 ga					1	4.0	3 x 3 7 ga	1
	78"x15"	7	17.6	2	2.5 x 2.5 12 ga					2	4.0	3 x 3 7 ga	2
	84"x15"	7	15.8	2	2.25 x 2.25 12 ga					2	4.0	2.5 x 2.5 12 ga	
	90"x15"	7	15.3	2	2.5 x 2.5 12 ga					2	4.0	3 x 3 7 ga	2
	96"x15"	7	17.4	2	2.5 x 2.5 10 ga					2	4.0	3 x 3 7 ga	2
	48"x12"	7	17.5	1	2.5 x 2.5 12 ga					1	4.0	3 x 3 7 ga	
	54"x12"	7	15.2	1	2.25 x 2.25 12 ga					1	4.0	2.5 x 2.5 12 ga	
	60"x12"	7	14.2	1	2.5 x 2.5 12 ga					1	4.0	3 x 3 7 ga	
	66"x12"	7	15.9	1	2.5 x 2.5 12 ga					1	4.0	3 x 3 7 ga	
	72"x12"	7	14.7	1	2.5 x 2.5 12 ga					1	4.0	3 x 3 7 ga	
	78"x12"	7	15.7	2	2 x 2 12 ga					2	4.0	2.25 x 2.25 12 ga	
	84"x12"	7	15.6	2	2.25 x 2.25 12 ga					2	4.0	2.5 x 2.5 12 ga	
	90"x12"	7	18.6	2	2.5 x 2.5 12 ga					2	4.0	3 x 3 7 ga	2
	96"x12"	7	17.5	2	2.5 x 2.5 12 ga					2	4.0	3 x 3 7 ga	2
	48"x12"	5	20.3	1	2 x 2 12 ga					1	4.0	2.25 x 2.25 12 ga	
	30"x12"	5	16.4	1	2 x 2 12 ga					1	4.0	2.25 x 2.25 12 ga	
	36"x12"	5	13.8	1	2 x 2 12 ga					1	4.0	2.25 x 2.25 12 ga	
	42"x12"	5	14.7	1	2 x 2 12 ga					1	4.0	2.25 x 2.25 12 ga	
	48"x12"	5	12.9	1	2 x 2 12 ga					1	4.0	2.25 x 2.25 12 ga	
	54"x12"	5	15.2	1	2.25 x 2.25 12 ga					1	4.0	2.5 x 2.5 12 ga	
	60"x12"	5	13.8	1	2.25 x 2.25 12 ga					1	4.0	2.5 x 2.5 12 ga	
	24"x9"	5	24.1	1	2 x 2 12 ga					1	4.0	2.25 x 2.25 12 ga	
	30"x9"	5	21	1	2 x 2 12 ga					1	4.0	2.25 x 2.25 12 ga	
	36"x9"	5	17.3	1	2 x 2 12 ga					1	4.0	2.25 x 2.25 12 ga	
	42"x9"	5	15.4	1	2 x 2 12 ga					1	4.0	2.25 x 2.25 12 ga	
	48"x9"	5	13.5	1	2 x 2 12 ga					1	4.0	2.25 x 2.25 12 ga	
54"x9"	5	14.8	1	2 x 2 12 ga					1	4.0	2.25 x 2.25 12 ga		
60"x9"	5	13.3	1	2 x 2 12 ga					1	4.0	2.25 x 2.25 12 ga		
Special Assembly 2	24"x12"	5	17.2	1	2.5 x 2.5 10 ga					1	4.0	3 x 3 7 ga	1
	30"x12"	5	16.3	1	2.5 x 2.5 10 ga					1	4.0	3 x 3 7 ga	1
	36"x12"	5	15.4	1	2.5 x 2.5 10 ga					1	4.0	3 x 3 7 ga	1
	42"x12"	5	14.6	1	2.5 x 2.5 10 ga					1	4.0	3 x 3 7 ga	1
	48"x12"	5	15.2	1	2.25 x 2.25 12 ga	4.5			2 x 2 12 ga	1	4.0	3 x 3 7 ga	1
	54"x12"	5	20.6	1	2.5 x 2.5 10 ga	1.5			2.19 x 2.19 10 ga	1	4.0	3 x 3 7 ga	1
	60"x12"	5	16.7	1	2.5 x 2.5 12 ga	3.9			2.25 x 2.25 12 ga	1	4.0	3 x 3 7 ga	1
	24"x9"	5	15.2	1	2.5 x 2.5 12 ga					1	4.0	3 x 3 7 ga	
	30"x9"	5	14.4	1	2.5 x 2.5 12 ga					1	4.0	3 x 3 7 ga	
	36"x9"	5	16.4	1	2.5 x 2.5 10 ga					1	4.0	3 x 3 7 ga	1
	42"x9"	5	15.8	1	2.5 x 2.5 10 ga					1	4.0	3 x 3 7 ga	1
	48"x9"	5	14.4	1	2.5 x 2.5 10 ga					1	4.0	3 x 3 7 ga	1
	54"x9"	5	15.1	1	2.25 x 2.25 12 ga	4.2			2 x 2 12 ga	1	4.0	3 x 3 7 ga	1
	60"x9"	5	14.5	1	2.25 x 2.25 12 ga	4.7			2 x 2 12 ga	1	4.0	3 x 3 7 ga	1

POST INFORMATION FOR VARIOUS SIGN CONFIGURATIONS													
ASSEMBLY NUMBER	STREET NAME SIGN SIZE	VERTICAL CLEARANCE	MAXIMUM POST LENGTH	NUMBER OF POSTS	SUPPORT SIZE	SLEEVE LENGTH (A)			SLEEVE SIZE	ANCHOR			BREAKAWAY
						1st	2nd	3rd		NUMBER	LENGTH	SIZE	
						LF	LF	LF					
Special Assembly 3	24"x12"	5	16.2	1	2.5 x 2.5 10 ga					1	4.0	3 x 3 7 ga	1
	30"x12"	5	15.3	1	2.5 x 2.5 10 ga					1	4.0	3 x 3 7 ga	1
	36"x12"	5	15.9	1	2.25 x 2.25 12 ga	4.3			2 x 2 12 ga	1	4.0	3 x 3 7 ga	1
	42"x12"	5	15.2	1	2.25 x 2.25 12 ga	4.8			2 x 2 12 ga	1	4.0	3 x 3 7 ga	1
	48"x12"	5	15.2	1	2.5 x 2.5 12 ga	5			2.25 x 2.25 12 ga	1	4.0	3 x 3 7 ga	1
	54"x12"	5	20.6	1	2.5 x 2.5 10 ga	1.9			2.19 x 2.19 10 ga	1	4.0	3 x 3 7 ga	1
	60"x12"	5	16	1	2.5 x 2.5 12 ga	4.7			2.25 x 2.25 12 ga	1	4.0	3 x 3 7 ga	1
	24"x9"	5	16.8	1	2.5 x 2.5 10 ga					1	4.0	3 x 3 7 ga	1
	30"x9"	5	16.1	1	2.5 x 2.5 10 ga					1	4.0	3 x 3 7 ga	1
	36"x9"	5	15.4	1	2.5 x 2.5 10 ga					1	4.0	3 x 3 7 ga	1
	42"x9"	5	14.9	1	2.5 x 2.5 10 ga					1	4.0	3 x 3 7 ga	1
	48"x9"	5	15.7	1	2.25 x 2.25 12 ga	4.2			2 x 2 12 ga	1	4.0	3 x 3 7 ga	1
Special Assembly 4	54"x9"	5	14.9	1	2.5 x 2.5 12 ga	4.8			2.25 x 2.25 12 ga	1	4.0	3 x 3 7 ga	1
	60"x9"	5	20.5	1	2.5 x 2.5 10 ga	1.6			2.19 x 2.19 10 ga	1	4.0	3 x 3 7 ga	1
	24"x12"	5	15.1	1	2.25 x 2.25 12 ga	4.8			2 x 2 12 ga	1	4.0	3 x 3 7 ga	1
	30"x12"	5	15.1	1	2.5 x 2.5 12 ga	5			2.25 x 2.25 12 ga	1	4.0	3 x 3 7 ga	1
	36"x12"	5	17.4	1	2.5 x 2.5 12 ga	3.6			2.25 x 2.25 12 ga	1	4.0	3 x 3 7 ga	1
	42"x12"	5	16.8	1	2.5 x 2.5 12 ga	4.1			2.25 x 2.25 12 ga	1	4.0	3 x 3 7 ga	1
	48"x12"	5	16.1	1	2.5 x 2.5 12 ga	4.5			2.25 x 2.25 12 ga	1	4.0	3 x 3 7 ga	1
	54"x12"	5	15.5	1	2.5 x 2.5 12 ga	4.9			2.25 x 2.25 12 ga	1	4.0	3 x 3 7 ga	1
	60"x12"	5	16.7	1	2.5 x 2.5 10 ga	4.2			2.19 x 2.19 10 ga	1	4.0	3 x 3 7 ga	1
	24"x9"	5	15.5	1	2.25 x 2.25 12 ga	4.2			2 x 2 12 ga	1	4.0	3 x 3 7 ga	1
	30"x9"	5	15	1	2.25 x 2.25 12 ga	4.5			2 x 2 12 ga	1	4.0	3 x 3 7 ga	1
	36"x9"	5	14.5	1	2.25 x 2.25 12 ga	4.8			2 x 2 12 ga	1	4.0	3 x 3 7 ga	1
Special Assembly 5	42"x9"	5	14.7	1	2.5 x 2.5 12 ga	4.9			2.25 x 2.25 12 ga	1	4.0	3 x 3 7 ga	1
	48"x9"	5	17.2	1	2.5 x 2.5 12 ga	3.5			2.25 x 2.25 12 ga	1	4.0	3 x 3 7 ga	1
	54"x9"	5	15.8	1	2.5 x 2.5 12 ga	4.4			2.25 x 2.25 12 ga	1	4.0	3 x 3 7 ga	1
	60"x9"	5	15.3	1	2.5 x 2.5 12 ga	4.7			2.25 x 2.25 12 ga	1	4.0	3 x 3 7 ga	1
	24"x12"	5	17.1	2	2.5 x 2.5 10 ga					2	4.0	3 x 3 7 ga	2
	30"x12"	5	16.7	2	2.5 x 2.5 10 ga					2	4.0	3 x 3 7 ga	2
	36"x12"	5	17.7	2	2.25 x 2.25 12 ga	4	4.5		2 x 2 12 ga	2	4.0	3 x 3 7 ga	2
	42"x12"	5	17.3	2	2.25 x 2.25 12 ga	4.3	4.8		2 x 2 12 ga	2	4.0	3 x 3 7 ga	2
	48"x12"	5	16.8	2	2.25 x 2.25 12 ga	4.5	5		2 x 2 12 ga	2	4.0	3 x 3 7 ga	2
	54"x12"	5	16.5	2	2.25 x 2.25 12 ga	4.8	5.3		2 x 2 12 ga	2	4.0	3 x 3 7 ga	2
	60"x12"	5	17.5	3	2.5 x 2.5 12 ga					3	4.0	3 x 3 7 ga	3
	24"x9"	5	17.3	2	2.5 x 2.5 10 ga					2	4.0	3 x 3 7 ga	2
30"x9"	5	17	2	2.5 x 2.5 10 ga					2	4.0	3 x 3 7 ga	2	
36"x9"	5	16.6	2	2.5 x 2.5 10 ga					2	4.0	3 x 3 7 ga	2	
42"x9"	5	16.3	2	2.5 x 2.5 10 ga					2	4.0	3 x 3 7 ga	2	
48"x9"	5	16	2	2.5 x 2.5 10 ga					2	4.0	3 x 3 7 ga	2	
54"x9"	5	17.1	2	2.25 x 2.25 12 ga	4	4.6		2 x 2 12 ga	2	4.0	3 x 3 7 ga	2	
60"x9"	5	16.8	2	2.25 x 2.25 12 ga	4.2	4.8		2 x 2 12 ga	2	4.0	3 x 3 7 ga	2	

(A) The sleeve length shown is for the maximum post length. The required sleeve length is the "sleeve length" minus the difference between the "maximum post length" and the post length required in the field.

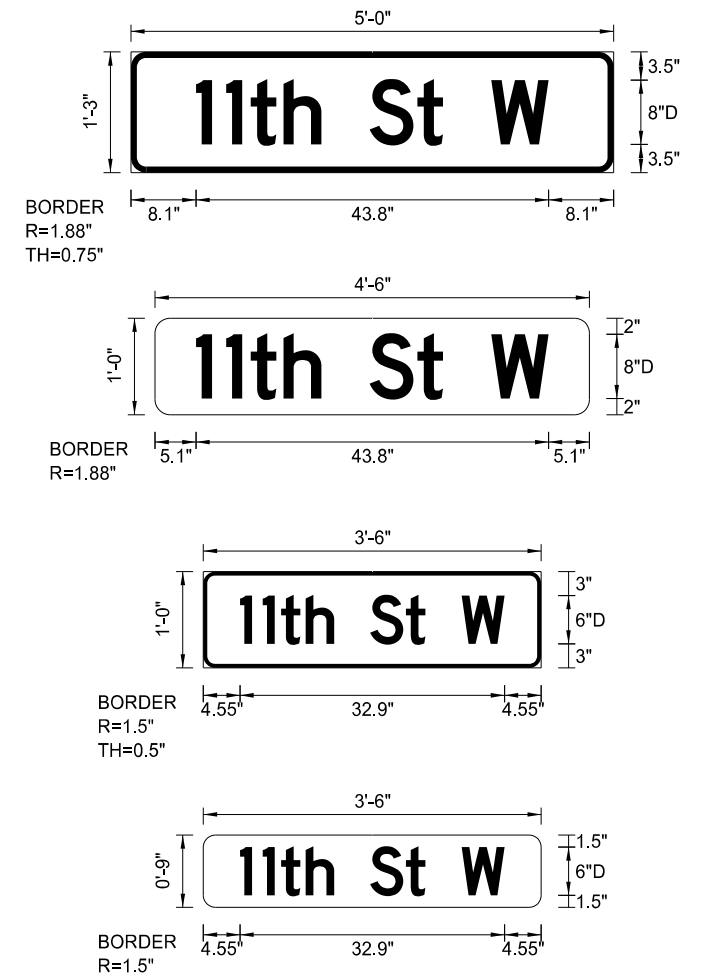

Notes:
Use 6 inch legend except on multi-lane divided roads with speeds of 45 mph or greater.
On divided multi-lane roadways, do not place 911 signs on top of stop sign.

When installing signs on existing supports, check support and sleeve size to determine if they meet table requirements. Measure maximum post length from ground to top of street name sign. If calculated support length is greater than maximum post length shown, recalculate support size.

See Standard Drawing D-754-87 for sign punching, stringer and support location details.

NORTH DAKOTA DEPARTMENT OF TRANSPORTATION	
10-3-13	
REVISIONS	
DATE	CHANGE
7-18-14	Revised street name sign layouts.
8-30-18	Revised tables, lettering, & signs
9-05-19	and updated notes to active voice. New Design Engineer PE Stamp.

This document was originally issued and sealed by
Kirk J Hoff,
Registration Number
PE- 4683,
on 9/05/19 and the original document is stored at the North Dakota Department of Transportation

SIGN PUNCHING, STRINGER AND SUPPORT LOCATION DETAILS FOR STREET NAME SIGNS AND 911 SIGNS

- A - Single sign
- B - Single sign back to back
- C - Single sign each direction
- D - Single sign one direction, back to back other direction
- E - Back to back both directions

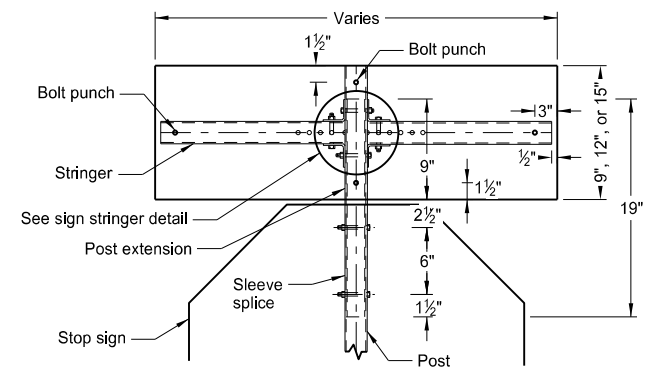
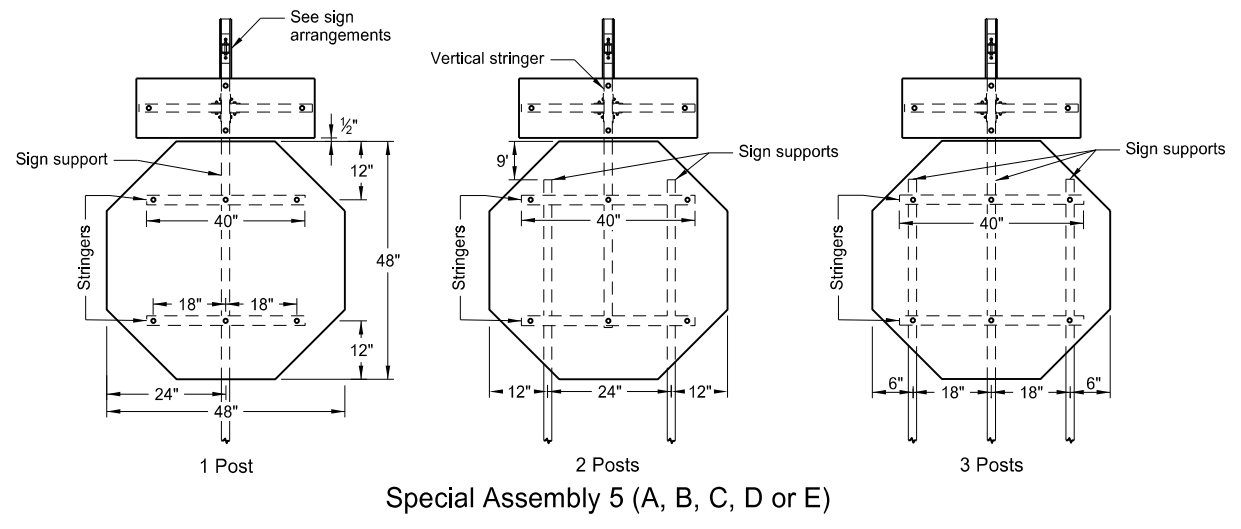
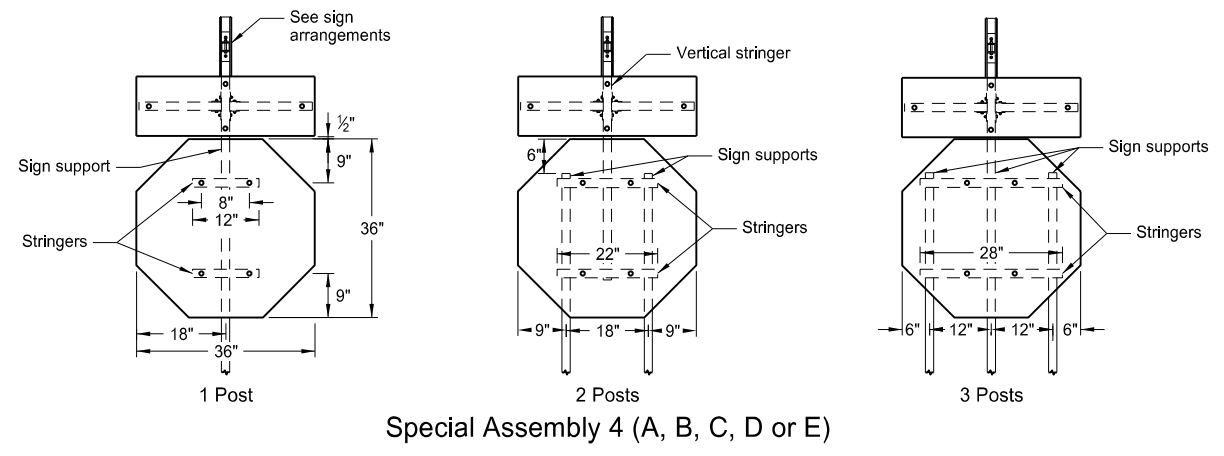
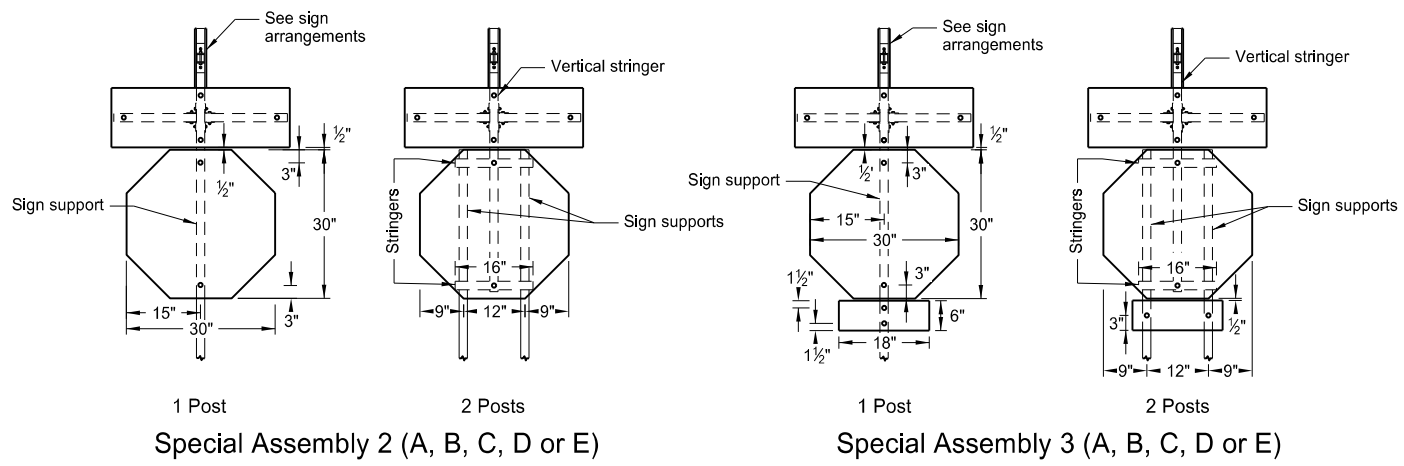
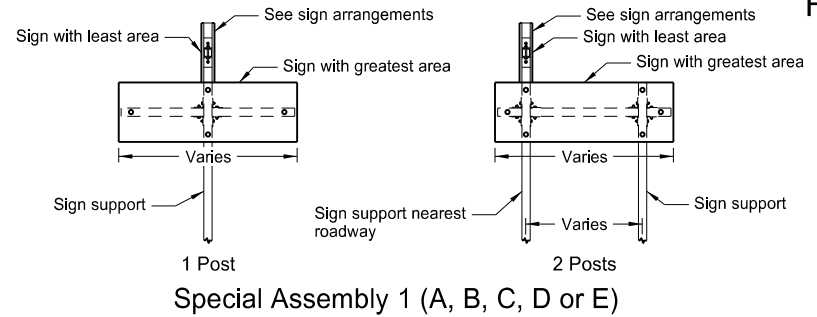

Note: Only use splice method with approval of engineer.

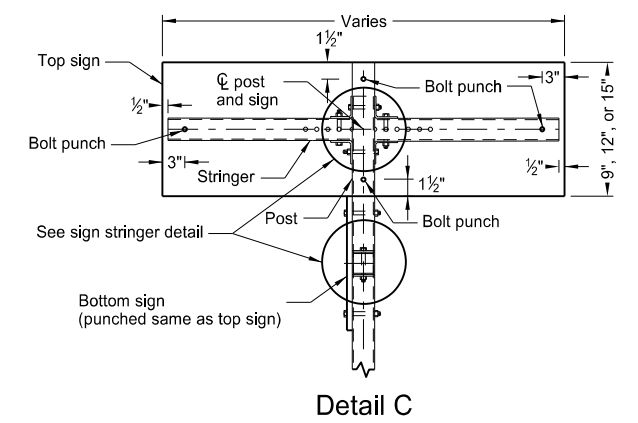
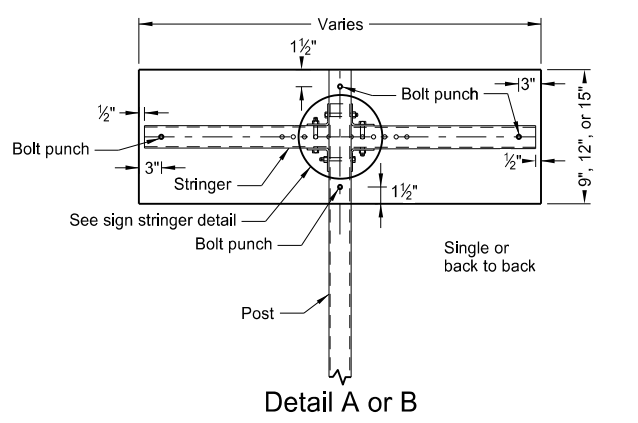
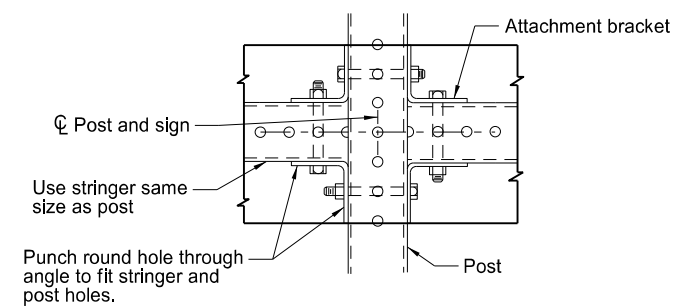

Sign Arrangements

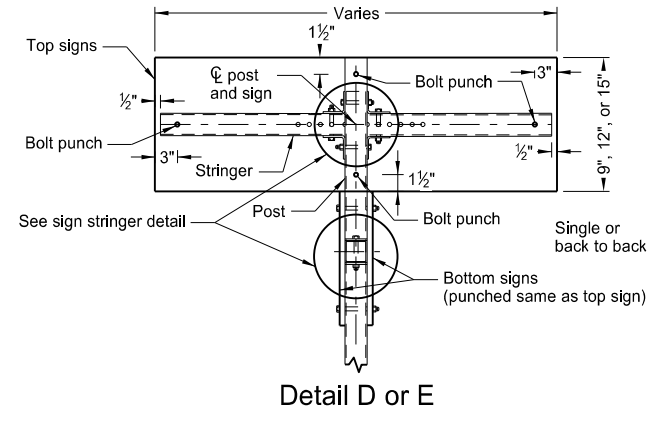

Note: See Standard Drawing D-754-86 for 911 support information and sign layout details.

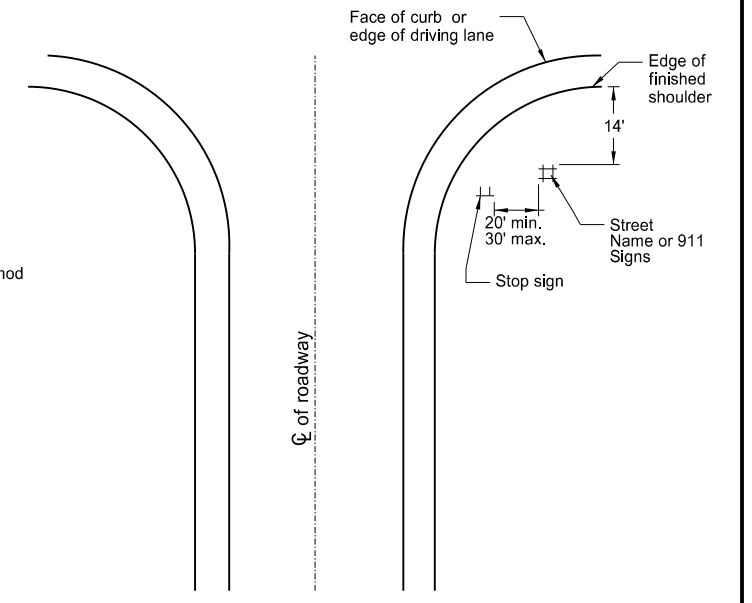

Note: Use layout for street name signs or 911 signs with Special Assembly 1.

NORTH DAKOTA DEPARTMENT OF TRANSPORTATION	
10-3-13	
REVISIONS	
DATE	CHANGE
8-30-18	Added 2 post layout for SA1 and Updated notes to active voice.
9-05-19	New Design Engineer PE Stamp.

This document was originally issued and sealed by
 Kirk J Hoff,
 Registration Number
 PE- 4683,
 on 9/05/19 and the original document is stored at the North Dakota Department of Transportation