

DESIGN DATA			
Traffic		Average Daily (Northbound)	
Current 2016	Pass: 2,990	Trucks: 810	Total: 3,800
Forecast 2036	Pass: 4,040	Trucks: 1,095	Total: 5,135
Traffic		Average Daily (Southbound)	
Current 2016	Pass: 2,745	Trucks: 705	Total: 3,450
Forecast 2036	Pass: 3,710	Trucks: 955	Total: 4,665
Clear Zone Dist. 34 LF (6:1)		Design Speed: 75 mph	
Minimum Sight Dist. for Stopping: 820 ft		Bridges: HS-20	
Full Control of Access, No Point of Access Other Than at Interchange Ramps			
Pavement Design Life 30 (years)			
Design Accumulated One-way 9,405,230 Trucks: Rigid Pavement			

JOB # 43
NORTH DAKOTA
DEPARTMENT OF TRANSPORTATION

STATE	PROJECT NO.	PCN	SECTION NO.	SHEET NO.
ND	IM-8-029(170)033	21496	1	1

IM-8-029(170)033

GOVERNING SPECIFICATIONS:

2014 Standard Specifications adopted by the North Dakota Department of Transportation and the Supplemental Specifications effective on the date the project is advertised.

PROJECT NUMBER \ DESCRIPTION	NET MILES	GROSS MILES
IM-8-029(170)033	10.570	10.717

Richland County
 Interstate 29 - N of Galchutt Exit to Christine Exit
 Southbound Reconstruction
 PCC Pavement, Mill & HMA Overlay, Ramp Connections
 Bridge Deck Replacement, Box Culvert Extension, Culverts, Guardrail, Fencing, & Incidentals

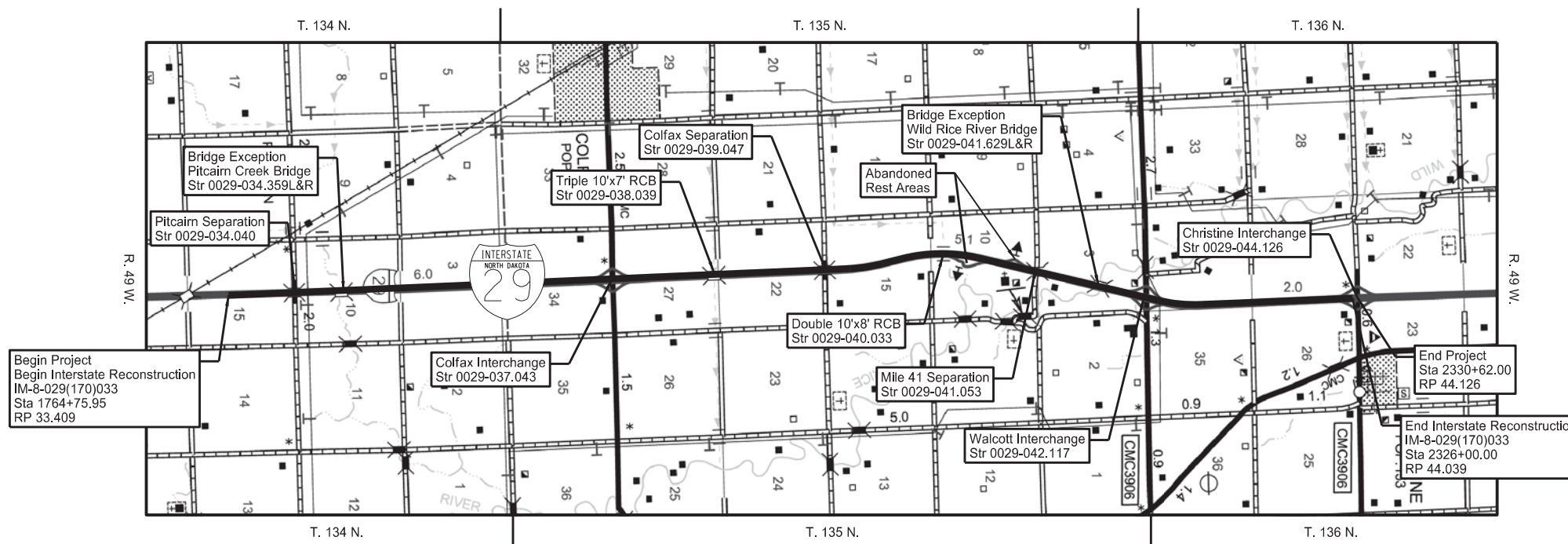

Legal Description
 T. 136 N. R. 49 W. - Sec 22, 23, 26, 27, 34, 35
 T. 135 N. R. 49 W. - Sec 2, 3, 10, 15, 22, 27, 34
 T. 134 N. R. 49 W. - Sec 3, 10, 15, 22

RP	Southbound	Northbound
32	Sta 1688+98	Sta 1688+94
33	Sta 1742+00	Sta 1742+28
34	Sta 1794+56	Sta 1794+55
35	Sta 1847+33	Sta 1847+32
36	Sta 1900+13	Sta 1900+13
37	Sta 1952+92	Sta 1952+93
38	Sta 2005+73	Sta 2005+71
39	Sta 2058+51	Sta 2058+50
40	Sta 2112+53	Sta 2112+53
41	Sta 2165+43	Sta 2165+50
42	Sta 2218+22	Sta 2218+24
43	Sta 2270+99	Sta 2270+94
44	Sta 2323+76	Sta 2323+74
45	Sta 2376+53	Sta 2376+46

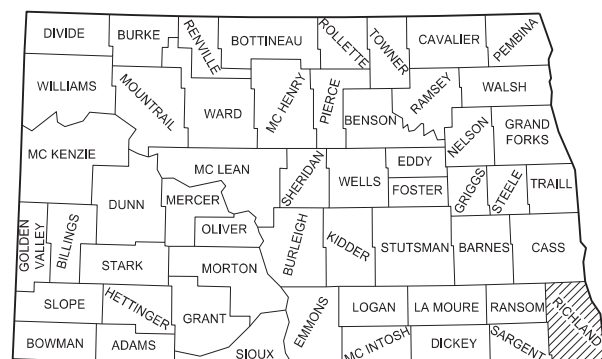
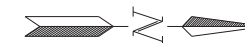

STATE COUNTY MAP

DESIGNERS	
Matt Lange, PE	
Jonathan D. Bach, PE	
Andrew J. Krebs, PE	
Jessica R. Karls, PE	Dustin Kinnischtzke, PE
John Schonert	Sean Kelly

I hereby certify that the attached plans were prepared by me or under my direct supervision and that I am a duly registered professional engineer under the laws of the state of ND.

APPROVED DATE 08/10/2017

Roger Weigel /s/
 OFFICE OF PROJECT DEVELOPMENT
 ND DEPARTMENT OF TRANSPORTATION

APPROVED DATE 08/07/2017

Chad A. Petersen /s/
 KLJ

This document was originally issued and sealed by Chad A. Petersen, Registration Number PE- 4884, on 08/07/17 and the original document is stored at the North Dakota Department of Transportation

TABLE OF CONTENTS

STATE	PROJECT NO.	SECTION NO.	SHEET NO.
ND	IM-8-029(170)033	2	1

PLAN SECTIONS

SPECIAL PROVISIONS

Section	Page(s)	Description
1	1	Title Sheet
2	1 - 2	Table of Contents & List of Standard Drawings
4	1	Scope of Work
6	1 - 6	Notes
6	7	Environmental Notes
8	1	Quantities
10	1 - 4	Basis of Estimate
11	1 - 2	Earthwork Summary
11	3 - 10	Average End Area Tables
11	11	Mass Haul Diagram
20	1 - 2	Superelevation Detail
20	3	Milling & Paving Transition Detail
20	4	Median Approach Detail
20	5	PCC Pavement & Joint Details
20	6	Mainline Centerline Pipe Extension Detail
20	7	Erosion Control at Culvert Flared End Sections
20	8	Median Drain Detail
20	9	Median Block Detail
20	10	Riprap Detail
20	11	South Median Crossover Paving Detail
20	12	Subcut Detail
20	13	Speed Measurement Pavement Markings
30	1 - 7	Typical Sections
40	1 - 25	Removals
50	1	Hydraulic Data
51	1 - 3	Allowable Pipe List
60	1 - 34	Plan & Profile
75	1 - 20	Wetland Impacts
76	1 - 15	Temporary Erosion Control
77	1 - 15	Permanent Erosion Control
80	1 - 12	Layouts
81	1 - 8	Survey Coordinate and Curve Data
82	1 - 16	Survey Data Layouts
90	1 - 7	Paving Layouts
100	1 - 35	Work Zone Traffic Control
110	1 - 32	Signing
130	1 - 9	Guardrail
170	1 - 34	Bridges and Box Culverts
200	1 - 289	Cross Sections - Interstate 29
200	290 - 376	Cross Sections - Ramp Connections

Number	Description
SP 003(14)	Temporary Erosion and Sediment Best Management Practices
SP 004(14)	Federal Migratory Bird Treaty Act
SP 5171(14)	Permits and Environmental Considerations

TABLE OF CONTENTS
LIST OF STANDARD DRAWINGS

	STATE	PROJECT NO.	SECTION NO.	SHEET NO.
	ND	IM-8-029(170)033	2	2

Number	Description	Number	Description
D-101-1, 2,3	NDDOT Abbreviations	D-720-1	Standard Monuments And Right Of Way Markers
D-101-10	NDDOT Utility Company and Organization Abbreviations	D-722-3	Inlet - Mountable Curb
D-101-20, 21	Line Styles	D-722-7	Precast Concrete Median Drain
D-101-30, 31,32	Symbols	D-748-1	Curb & Gutter And Valley Gutter
D-255-1	Bridge Approach Slab Drainage Detail	D-754-1	Pipe Or W-Shape Assembly Details
D-255-2	Erosion And Siltation Control - Erosion Control Blanket Installation	D-754-2	Breakaway Coupler System For Standard Pipe - Stub Post
D-260-1	Erosion And Siltation Controls - Silt Fence	D-754-3	Breakaway System for Standard Pipe - Stub Post
D-261-1	Erosion Control - Fiber Roll Placement Details	D-754-4	Multi-Directional Breakaway System for Standard Pipe - Stub Post
D-550-2	Longitudinal Joint Details	D-754-5	Foundation Data For Steel Supports
D-550-5	Transverse Construction Joint	D-754-6	Hinge Plate, Fuse Plate, And Foundation Details For Standard Pipe
D-704-1	Attenuation Device	D-754-7	Pipe Support And Sign Mounting Details
D-704-5	Contractor Sign Detail	D-754-9	Letter And Arrow Details For Variable Length Signs
D-704-7	Breakaway Systems For Construction Zone Signs - Perforated Tube	D-754-12	Breakaway Coupler System - Structural Details For W-Shape Supports
D-704-8	Breakaway Systems For Construction Zone Signs - U-Channel Post	D-754-13	Breakaway System Structural Details For W-Shape Supports
D-704-9	Construction Sign Details - Terminal And Guide Signs	D-754-14	Wind Beams And Anchor Plates For W-Shape Supports
D-704-10	Construction Sign Details - Regulatory Signs	D-754-20	(Expressway-Freeway Use) Mile Posts
D-704-11	Construction Sign Details - Warning Signs	D-754-21	Reflectorized Delineators
D-704-12	Shoulder Closure Tapers	D-754-22A	Typical Interchange Delineation
D-704-13	Barricade And Channelizing Device Details	D-754-22B	Typical Rest Area Delineation
D-704-14	Construction Sign Punching And Mounting Details	D-754-23	Perforated Tube Assembly Details
D-704-15	Road Closure Layouts	D-754-24, 25	Mounting Details Perforated Tube
D-704-17	Sign Layout For One Lane Closure Two Lane Roadway	D-754-24A	Breakaway Coupler System For Perforated Tubes
D-704-21	Detour And Roadway Diversion Sign Layouts	D-754-32	Sign Punching, Stringer And Support Location Details Regulatory, Warning, And Guide Signs
D-704-22	Construction Truck And Temporary Detour Layouts	D-754-49	Sign Punching, Stringer And Support Location Details For Variable Length Signs
D-704-26	Miscellaneous Sign Layouts	D-754-83	Object Markers - Culverts
D-704-27	Traffic Control Plan For Moving Operations	D-760-1	Rumble Strips Interstate Highways
D-704-35	Sign Layout For One Lane Closure - Interstate System	D-762-2	Interstate Pavement Marking 4 Lane Divided Highway
D-704-38, 39	Traffic Control System-Median Crossover (800 Ft Transition)-55 Mph Speed Limit Or Greater	D-762-4	Pavement Marking
D-704-45	Construction Signing Median Crossover	D-762-11	Short-Term Pavement Marking
D-704-50	Portable Sign Support Assembly	D-764-1	W-Beam Guardrail General Details
D-704-51	Portable Precast Concrete Median Barrier (Temporary Usage)	D-764-5	Sequential Kinking Terminal
D-704-56	Mobile Operation - Grinding Shoulder Rumble Strips	D-764-6	Flared Energy Absorbing Terminal
D-706-1	Bituminous Laboratory	D-764-10	Thrie Beam Transition To Double Box Beam Retrofit
D-708-6	Erosion And Siltation Controls - Median Or Ditch Inlet Protection	D-764-38	MGS Flared Energy Absorbing Terminal - Wood Post
D-714-1	Reinforced Concrete Pipe Culverts And End Sections (Round Pipe)	D-764-40	MGS W-Beam Guardrail General Details
D-714-22	Concrete Pipe Or Precast Concrete Box Culvert Ties	D-764-48	Typical Grading at Bridge Ends with MGS W-Beam Guardrail
D-714-25	Transverse Mainline Pipe Installation Detail for Pipes More Than 4 Feet Below Top of the Proposed Subgrade	D-764-50	MASH SoftStop End Terminal - Steel Post
D-714-25M	Transverse Mainline Pipe Installation Detail for Multiple Pipes More Than 4 Feet Below the Top of Subgrade	D-764-51	MASH Sequential Kinking Terminal - Wood Post
D-714-26	Transverse Mainline Pipe Installation Detail for Pipes 4 Feet or Less Below Top of the Proposed Subgrade	D-764-60	MGS W-Beam Transition with Approach Curb to Concrete Single Slope or Jersey Barrier
D-714-26M	Transverse Mainline Pipe Installation Detail for Multiple Pipes 4 Feet or Less Below Top of Subgrade	D-764-61	Single Slope to Thrie Beam Connector Plate Details
D-714-27M	Pipe Installation Detail for Multiple Longitudinal Mainline Pipe or Pipe Not Under Roadway	D-900-1	Bridge Bench Marks



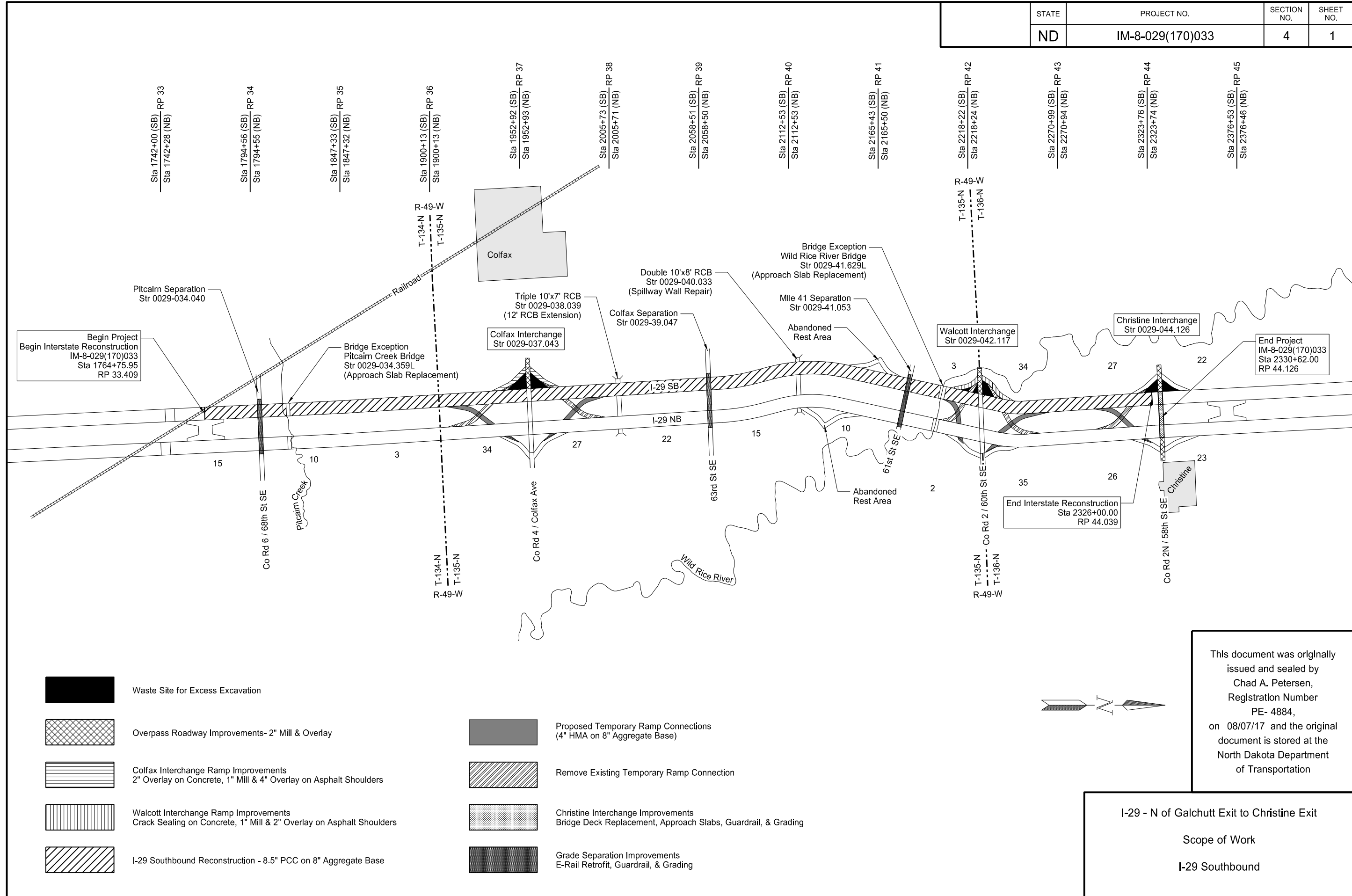

STATE	PROJECT NO.	SECTION NO.	SHEET NO.
ND	IM-8-029(170)033	4	1







Begin Project
Begin Interstate Reconstruction
IM-8-029(170)033
Sta 1764+75.95
RP 33.409

End Project
IM-8-029(170)033
Sta 2330+62.00
RP 44.126

End Interstate Reconstruction
Sta 2326+00.00
RP 44.039

-  Waste Site for Excess Excavation
-  Overpass Roadway Improvements- 2" Mill & Overlay
-  Colfax Interchange Ramp Improvements
2" Overlay on Concrete, 1" Mill & 4" Overlay on Asphalt Shoulders
-  Walcott Interchange Ramp Improvements
Crack Sealing on Concrete, 1" Mill & 2" Overlay on Asphalt Shoulders
-  I-29 Southbound Reconstruction - 8.5" PCC on 8" Aggregate Base

-  Proposed Temporary Ramp Connections
(4" HMA on 8" Aggregate Base)
-  Remove Existing Temporary Ramp Connection
-  Christine Interchange Improvements
Bridge Deck Replacement, Approach Slabs, Guardrail, & Grading
-  Grade Separation Improvements
E-Rail Retrofit, Guardrail, & Grading

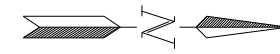

This document was originally issued and sealed by
Chad A. Petersen,
Registration Number
PE- 4884,
on 08/07/17 and the original document is stored at the
North Dakota Department
of Transportation

I-29 - N of Galchutt Exit to Christine Exit

Scope of Work

I-29 Southbound

NOTES

STATE	PROJECT NO.	SECTION NO.	SHEET NO.
ND	IM-8-029(170)033	6	1

105-P01 PAVEMENT SWEEPING: Sweep paved areas that were used by construction traffic before opening these areas to public traffic.

Sweep all newly constructed pavement no more than 24 hours before a scheduled final inspection.

105-P02 SURVEYING: The Engineer will provide a control line for the Contractor to use to establish rough grades. The Engineer will also provide no more than two string lines (hub lines) for trimming/concrete paving operation (same hub line). An additional string line may be provided for the trimming/paving of the wide shoulder as approved by the Engineer.

106-P01 ABANDONED REST AREAS: The abandoned rest areas and the entrance/exit ramps will not be allowed as a staging area for construction.

107-300 CONSTRUCTION TRAFFIC ACCESS: Access areas within the right of way only at interchanges. The Engineer may allow temporary access at other locations. To obtain temporary access, provide an access plan containing the following information:

- A traffic control plan;
- A traffic impact analysis;
- A safety analysis; and
- An environmental impact analysis.

If the Engineer determines that the information is adequate, the Engineer will submit the information to FHWA for approval and environmental clearance.

To be considered for approval, the following minimum conditions must be met in the access plan:

- Construction traffic will not be allowed to cross the interstate median or lanes of traffic being used by the public at grade;
- The access plan must show that there will be methods in place, at all times, to prevent public traffic from using the access;
- A plan to restore the area disturbed by the access, including right of way fences, to preexisting or better condition.

All work necessary to provide the access plan, comply with the plan, and to restore the area to its pre-existing condition must be completed at no additional cost to the Department.

108-100 WEEKLY PLANNING & REPORTING MEETING: A weekly planning and reporting meeting is required.

202-P01 REMOVAL OF PAVEMENT: Removal of pavement consists of removing and salvaging concrete pavement, doweled jointed pavement, bituminous pavement and aggregate base. It is assumed that aggregate base within the I-29 footprint will not be salvageable, and is included in the quantities for "Reshaping Roadway". Existing pavement thicknesses are averages based on previous construction plans and maintenance data.

202-P02 REMOVAL OF TEMPORARY BYPASS: After both northbound and southbound I-29 are open to traffic, remove the temporary ramp connections.

This work consists of:

1. Saw cut (if required) existing pavement to be removed at the edge of the finished shoulder.
2. Construct a slough at the edge of the saw cut matching the existing conditions.
3. Remove the temporary ramp connections within the gore area and regrade to existing conditions. Blend excess material into the existing terrain of the gore areas. Create a traversable surface as approved by the Engineer in the field.
4. Remove delineators adjacent to the temporary ramp connections.
5. Removal of bituminous surfacing, placing aggregate base, HMA Paving, resetting temporary pipe, and the required pipe extensions to be paid separately.

Include all costs, not specified to be paid for separately, in the price bid for "Removal of Temporary Bypass".

203-010 SHRINKAGE: 25 percent additional volume is included for shrinkage in earth embankment.

203-360 COMPACTION AND DENSITY CONTROL: Compact material as specified in Section 203.04 E.2.b, "ND T-99".

Manipulate embankment material with disking equipment.

203-P01 COMMON EXCAVATION SUBCUT: No subcuts are planned for the I-29 southbound mainline. However, if the Project Engineer determines that an area of the subgrade is too wet or unstable, a subcut may be required. A discretionary quantity for 500' of subcutting has been provided in the plans. Refer to Section 20 for details.

203-P02 AVERAGE HAUL: The average haul shown on the plans does not include the dead haul from the waste areas to the point of entry into the mass.

220-P01 STOCKPILE SITE: Obtain a stockpile site for salvaged materials.

230-P01 SUBGRADE PREPARATION: Determine the optimum moisture and density, as specified in ND T 99, for each type of material encountered that requires compaction control. Perform a multi-point test using a minimum of 4 points. Submit the results to the Engineer along with a split sample of each material.

The Engineer will perform comparison tests using the same procedure on the split sample. The Engineer's results will be used for determining in place density of material.

230-P02 RESHAPING TEMPORARY RAMPS: Include all costs associated with reshaping the temporary ramp connections within the median to accommodate the future ramp connections in the price bid for "RESHAPING ROADWAY".

230-P03 RESHAPING ROADWAY: Include all costs associated with the necessary earthwork required to reconstruct the corridor in the price bid for "Reshaping Roadway". Refer to the Mass Haul Diagram and the Summary of Earthwork Tables for a estimate of excavated material, required embankment and excess excavation.

All excess excavation is the property of the NDDOT. Haul and stockpile excess excavation at the following locations:

This document was originally issued and sealed by
 Matt Lange,
 Registration Number
 PE- 6870,
 on 08/11/17 and the original document is stored at the
 North Dakota Department
 of Transportation

NOTES

STATE	PROJECT NO.	SECTION NO.	SHEET NO.
ND	IM-8-029(170)033	6	2

- Christine Interchange
- Walcott Interchange
- Colfax Interchange

Clear and strip the storage site of topsoil prior to placement of the excess excavation. Blend the excess excavation into the existing terrain creating a traversable surface as approved by the Engineer in the field. Do not place material in wetlands or change existing drainage patterns. Restore topsoil, seed and mulch the stockpile upon approval of the grading by the Engineer in the field. Include all costs for clearing and grubbing, hauling, placing and grading of excess excavation and restoration of the stockpile site in the price bid for "Reshaping Roadway". Topsoil stripping and seeding quantities will be paid for separately at unit prices bid.

- 251-P01 FERTILIZER: After placing topsoil, but prior to seeding, place fertilizer that meets the requirements of Section 251.03 G, "Fertilizer". Do not place fertilizer in wetlands. Include all costs associated with the placement of fertilizer in the price bid for "Seeding Class II".
- 253-P01 HYDRAULIC MULCH: Delete section 253.04 B.2 of the Standard Specifications in its entirety.
- 261-P01 PERMANENT FIBER ROLLS: If fiber rolls are to remain on the project, use fiber rolls that are composed of netting that meets either of the following:
- Plastic or natural fiber photodegradable netting that has a life expectancy between 12 to 24 months. If the photodegradable netting is plastic, the netting color must be either clear or green. Black plastic netting will not be allowed.
- 100 percent biodegradable jute netting that has a life expectancy between 6 to 12 months.
- 302-P01 SALVAGED BASE COURSE: Surface tolerance for the salvaged base course will be in accordance with 302.04 C.2, Surface Tolerance Type C, for all areas beneath the 8.5" Non-Reinf Concrete Pavement CL AE – Doweled (i.e. mainline pavement, inside shoulder, and ramp gore area). Surface tolerance for the salvaged base course will be in accordance with 302.04 C.1, Surface Tolerance Type B, for the 8' outside shoulder and ramp areas. Reincorporate excess material removed from high points of the base course by the trimming operation into the base course.
- 302-P02 SALVAGED BASE COURSE FOR SUBCUT REPAIRS: Aggregate meeting the requirement of Class 3 or Class 5 specified in Section 816.02, "Miscellaneous Aggregates" may be used if no salvage based material is available at the time subcuts are filled. Aggregate used in subcut repairs is subject to the requirements of 302.04 B. Aggregate used in subcut repairs will be paid for at the contract unit price for "Salvaged Base Course" regardless of the class of material used.
- 302-P03 SALVAGED BASE COURSE: Incorporate all salvaged concrete and HBP material into the salvaged base course. Utilize recycled HBP or virgin aggregate for any additional material required for the salvaged base course.
- 302-P04 HAULING: The shoulder of southbound I-29 can be used as a haul route. Do not drive on the base course and/or geosynthetic material, except when the haul vehicle is dumping. When dumping, the haul vehicle is allowed to drive on the base course in the immediate vicinity of

where the load is dumped. Re-establish subgrade surface tolerance per contract requirements prior to placement of the salvaged base course.

- 401-P01 TRIMMING AND PRIME: Prime shoulders within one mile or within 48 hours of the trimming operations unless HBP paving is to take place within 24 hours of trimming.
- 430-P01 HMA DENSITY CONTROL: Compact HMA paving in accordance with Section 430.04 I.3. If Alternative B is selected 'Concrete Median Shoulder W/ 8' Asphalt Outside Shoulder', the asphalt shoulder will be compacted in accordance with Section 430.04 I.2.
- 430-P02 MAINTENANCE OF TRAVELED ROADWAY USING HOT MIX ASPHALT: The contractor will be fully responsible for monitoring the condition of the traveled roadway, crossovers and ramp connections within the limits of the project.
- Patch with an approved mix, in a reasonable time frame, any areas that have subsided more than one inch from the adjacent pavement, any rutting, sponginess and/or breakups as directed by the engineer. Compact HMA in accordance with Section 430.04 I.3 of the Standard Specifications. Include all cost of equipment, labor, and materials, including asphalt cement in the unit price bid for "Patching". Provide a traffic control plan that minimizes disruption to traffic. Necessary traffic control devices and flagging will be paid for under the normal contract bid item. Additionally, the contractor will be required to perform an initial inspection of the roadway, used by the traveling public before construction begins, and make all repairs in accordance with the above requirements or as directed by the Engineer. A quantity of 500 Tons of "Patching" has been provided for this purpose.
- 550-P01 CONCRETE PAVEMENT: The development of a maturity curve specified in Section 550.04 B, "Mix Design" will not be required.
- 550-P02 CONCRETE PAVEMENT: The Department will waive the requirement to place the reinforcing steel, tie bars and dowel bar assemblies a minimum of 2,000 feet ahead of the paving operation as stated in Sections 550.04 E.1 and 550.04 G.2 and allow the use of the roadway as a haul road at the Contractors request, provided the following conditions are met:
- Repair all damaged areas
 - Provide an additional trimmer in advance of the paving operation.
 - Construct the finished surface to within 0.10 feet of the proposed elevation with the first pass of trimming equipment.
 - Construct the finished surface to the specified surface tolerance prior to the placement of reinforcing steel, tie bars and dowel bar assemblies.
 - Place the reinforcing steel and tie bars on approved supports securely, properly and accurately in advancing of the paving operation.
- 704-100 TRAFFIC CONTROL SUPERVISOR: Provide a Traffic Control Supervisor.
- 704-200 PRECAST CONCRETE MEDIAN BARRIERS – STATE FURNISHED: Obtain 79 barriers from the rest area located at Sta 2160+00 Lt. After project completion return barriers to the abandoned rest area located at Sta 2160+00 Lt.
- Some 4 inch x 4 inch boards are available at the return location. Provide any additional 4 inch x 4 inch boards necessary to stack barriers. The boards will become property of the Department.

This document was originally issued and sealed by Matt Lange, Registration Number PE- 6870, on 08/07/17 and the original document is stored at the North Dakota Department of Transportation

NOTES

STATE	PROJECT NO.	SECTION NO.	SHEET NO.
ND	IM-8-029(170)033	6	3

Include the cost for boards in the contract unit price for "Precast Concrete Median Barrier - State Furnished".

704-300 FLASHING BEACON: Provide solar powered flashing beacons that meet the requirements of the MUTCD and ITE. Provide beacons that are visible for a distance of 0.25 miles (1,320 feet) and are capable of operating for 20 days without a solar charge.

Include all costs for materials, equipment, labor, and incidentals in the contract unit price for "Flashing Beacon".

704-301 SEQUENCING ARROW PANEL – TYPE C – CROSSOVER: Provide solar powered arrow panels that meet the requirements of the MUTCD and ITE and that are capable of operating for 20 days without a solar charge.

Include all costs for materials, equipment, labor, and incidentals in the contract unit price for "Sequencing Arrow Panel – Type C – Crossover".

704-P01 TRAFFIC CONTROL DEVICES: The traffic control devices list for each phase has been developed using traffic control signing layouts (shown in Section 100 of the plans) and Standard Drawings as listed below:

- D-704-01: Attenuation Device
- D-704-05, 7, 8, 9, 10, 11: Are applicable.
- D-704-12, 13, 14, 15, 17,21: Are applicable.
- D-704-22: Type K and L for construction trucks hauling material.
- D-704-26: Type CC, EE, and GG for milling and paving operations on the Colfax and Walcott ramps and crossroads as needed.
- D-704-27: Mobile operations.
- D-704-35: One lane closure on Interstate.
- D-704-38, 39: Median crossovers.
- D-704-45: Construction traffic median crossovers.
- D-704-50: Portable sign support assemblies.
- D-704-51: Portable precast concrete median barriers.
- D-704-56: Grinding shoulder rumble strips.

704-P02 TRAFFIC CONTROL PHASING: The traffic control details, as indicated on the plans, have been developed based on the premise that this project will be constructed in 5 phases. The traffic control device lists include the required number of devices for each phase of each described work area. The Contractor is responsible for removing and resetting devices for each phase of construction. The costs associated with removing and resetting traffic control devices is included in the price bid for other items.

The construction phasing plan is as listed below. Only one phase may be active at a time.

Phase 1: Close the outside lane of northbound I-29.

- Install W-beam guardrail and end terminal at Pitcairn Creek (east side of 0029-034.359R) and Wild Rice River (east side of 0029-041.629R).

Phase 2: Close the inside lane of northbound I-29.

- Install temporary w-beam guardrail, end terminals, and guardrail widening at Pitcairn Creek (west side of 0029-034.359R) and Wild Rice River (west side of 0029-041.629R).

- Obliterate existing pavement marking and install new temporary traffic control striping on the inside lane of northbound I-29 in preparation for Phase 3.
- Obliterate existing pavement marking and install raised pavement markers on the existing median crossovers in preparation for Phase 3.
- Install raised pavement markers and delineators at existing ramp connections inside the interstate median and ramp gore areas along southbound I-29 in preparation for Phase 3.

Phase 3: Close southbound I-29, implementing head to head traffic on northbound I-29.

- Activate the temporary ramp connections and median crossovers for the reconstruction of southbound I-29.
- Reconstruct southbound I-29.

Phase 4: Close the inside lane of northbound and southbound I-29.

- Remove temporary guardrail, end terminals, and guardrail widening at Pitcairn Creek (west side of 0029-034.359R) and Wild Rice River (west side of 0029-041.629R).
- Remove temporary ramp connections installed within the interstate median.
- Construct temporary ramp connections within the interstate median in preparation for future northbound I-29 reconstruction

Phase 5: Close the outside lane of southbound I-29. Close the outside lane of northbound I-29.

- Southbound I-29
 - Mill & overlay of the Colfax Interchange (RP 37.043) exit and entrance ramps.
 - Mill & overlay of Richland County Road 4 crossroad at the Colfax Interchange (RP 37.043).
 - Mill & overlay and crack sealing of the Walcott Interchange (RP 42.169) exit and entrance ramps.
 - Mill & overlay of Richland County Road 2 crossroad at the Walcott Interchange (RP 42.117).
 - Remove temporary ramp connections within the gore areas of each interchange.
 - The ramps will remain open to traffic during construction.
 - Work will be performed in stages with traffic being switched between the left and right sides of the ramps. Work on the ramps will not begin until after southbound I-29 is re-opened to traffic and temporary ramp connections within the interstate median have been removed and re-constructed for future northbound I-29 reconstruction.
- Northbound I-29
 - Remove temporary guardrail, end terminals, and guardrail widening at Pitcairn Creek (east side of 0029-034.359R) and Wild Rice River (east side of 0029-041.629R).
 - Install temporary ramp connections within the gore areas of each interchange in preparation for future northbound I-29 reconstruction.

704-P03 CHRISTINE INTERCHANGE DECK REPLACEMENT: The Christine interchange concrete deck can be replaced concurrently with any of the traffic control phasing with the exception of phase 5. The detour layout in Section 100 depicts the deck being replaced during phase 3. Adjust the detour traffic control to accommodate the appropriate phase.

This document was originally issued and sealed by Matt Lange, Registration Number PE- 6870, on 08/07/17 and the original document is stored at the North Dakota Department of Transportation

NOTES

STATE	PROJECT NO.	SECTION NO.	SHEET NO.
ND	IM-8-029(170)033	6	4

704-P04 INTERCHANGE RAMP CONNECTIONS: During the period that the mainline pavement being utilized for temporary ramp connections is being reconstructed, route the public traffic using the ramps around the paving area as shown in Section 100 of the plans. The proposed interstate and ramp paving must be complete and fully cured to prevent the need for temporary paving. Traffic then may use the new ramp for access to the interchange. Include all costs associated with temporary embankment and aggregate surfacing within the median and shifting traffic control to accommodate paving operations in the price bid for other items.

704-P05 TUBULAR MARKERS: Salvage existing triple-weighted tubular markers located at existing median crossovers and ramp connections. Immediately reset triple-weighted tubular markers at 5' spacing at all locations shown in Section 100 after completion of southbound I-29 reconstruction and the construction of the new temporary ramp connections in preparation for future northbound I-29 reconstruction. Add weight, as necessary, to triple-weighted tubular markers to achieve a minimum weight of 36 lbs.

The triple-weighted tubular markers will remain property of the state at the completion of the project. Include all cost for removing and resetting tubular markers in the unit price bid for "Tubular Markers."

704-P06 TRAFFIC CONTROL FOR HMA OVERLAYS: Provide traffic control consisting of a temporary lane closure and flagging.

The maximum work zone length is limited to one day's production.

For estimating purposes, the traffic control device list is based on the following list:

1. Standard D-704-22, Types K and L;
2. Standard D-704-26, Types CC, EE, and GG; and
3. Standard D-704-35.

If all or portions of the lane closure are removed and uneven lanes exist, provide traffic control as specified in Section 704.04 O, "Traffic Control for Uneven Pavement".

Complete work in a manner such that lane closures can safely be removed if no work is to take place for more than 3 consecutive days. Remove lane closures if no work is to take place for more than 3 consecutive days.

The Department will pay for all necessary deployed devices, regardless of the number and length of the lane closures.

704-P07 TRAFFIC CONTROL FOR SHOULDER DROP-OFF: During Phase 5, when constructing the temporary ramp connections within the gore area, if the shoulder and adjacent driving lane are not even at the end of the day, the following criteria will apply:

Place the following sign assembly at the locations listed below.

Sign Assembly: Sign No. W8-9a-48 "Shoulder Drop Off" and supplemental plate Sign No. W20-52-54 to identify the distance.

Locations:

- In advance of the drop off;
- Spaced at each mile from the advance sign; and

- At major intersections (CMC routes, state and US highways, and Interstate Ramps).

If the difference in elevation between the shoulder and the driving lane is 2" or greater, construct a slough on the driving lane that is 4:1 or flatter. If the difference in elevation between the shoulder and driving lane is less than 2", no slough is required. Sign assemblies will be measured and paid for according to Section 704 "Temporary Traffic Control".

704-P08 FLEXIBLE DELINEATORS: Bolt mount all temporary flexible delineators to be installed within the northbound roadway. Butyl pads will not be allowed. Upon removal of the devices, fill and seal all bolt holes as approved by the Engineer.

704-P09 PAVEMENT MARKING REMOVAL: Obliterate the centerline and edge lines as shown in Section 100 of the plans and Standard Drawings D-704-38 and D-704-39. At the interchange ramp connections, obliterate the centerline and edge lines as shown in Section 100 of the plans. No grinding will be allowed on new pavement surfaces for obliteration of existing pavement marking. Masking of existing pavement markings on the southbound roadway will be accepted. The obliteration of the markings will be paid by the square foot removed. Include the cost of all equipment, material, and labor, including the removal of sheeting, if used, in the price bid for "Obliteration of Pavement Marking."

706-P01 AGGREGATE LABORATORY: Supply an Aggregate Laboratory with a printer/copy machine. Include the cost in the contract unit price for "Aggregate Laboratory." The NDDOT Fargo district will provide the aggregate lab testing equipment.

706-P02 BITUMINOUS LABORATORY: If Alternative B is selected 'Concrete Median Shoulder W/ 8' Asphalt Outside Shoulder' supply a Bituminous Laboratory with a printer/copy machine. Include the cost in the contract unit price for "Bituminous Laboratory."

706-P03 FIELD OFFICE: Provide a field office which meets the following requirements:

1. The field office shall be a minimum of 450 square feet.
2. Indoor bathroom facilities and weekly cleaning services.
3. Air conditioner (20,000 BTU minimum)
4. Lighting (lumens required 110 foot- candles)
5. Minimum of 3 phone jacks (NDDOT to pay for phone service)
6. Heat, electric, sewer, and water hookups with potable water to be furnished by Contractor, Contractor to pay utility bills.
7. Cabinet space of a minimum of 32 cubic feet.
8. Counter space of a minimum of 40 square feet.
9. The floor is to be free of protrusions so that it will accommodate NDDOT furnished office equipment.
10. The location of the field office shall be on, or as close to the project as possible and approved by the Engineer. Any rental fees shall be paid by Contractor.
11. The field office shall be available for occupancy at the start of the project and remain available to project completion.
12. The following services will be furnished and paid for by the NDDOT and requested through the Work Management System:
 - a. Telephone
 - b. Broadband internet service including State Network access

This document was originally issued and sealed by Matt Lange, Registration Number PE- 6870, on 08/07/17 and the original document is stored at the North Dakota Department of Transportation

NOTES

STATE	PROJECT NO.	SECTION NO.	SHEET NO.
ND	IM-8-029(170)033	6	5

13. Photocopy/printer with scanning capabilities capable of 8.5x11 and 11x17 photocopies and toner to last the duration of the project. Other features to include digital copying, scanning, and USB port on the Copier/Printer. Copier/Printer machine with operating software compatible with that used by the NDDOT. A 12' printer cable is required.

All requirements of the Field Office are subject to approval by the Engineer. Include all costs associated with the field office in the price bid for "Field Office."

Schedule for Payments:

- 25% when set up on site
- 50% when 30% of work is complete
- 75% when 60% of work is complete
- 100% when project is complete

714-P01 INSTALL CONCRETE PIPE TIES: Expose and tie all centerline culverts within the project limits. Include all costs associated with exposing the centerline culverts, placing type S2 geotextile fabric over the joints and tying all concrete joints in the unit price bid for "Install Concrete Pipe Ties". Tie RCP in accordance with D-714-22. Backfill pipe in accordance with Section 714 of the Standard Specifications.

Pipe that has separated will be relayed at the discretion of the field Engineer. A discretionary quantity of 200 LF of "Remove & Relay Pipe-All Types & Sizes" has been provided in the plans. Place bedding for relayed pipe in accordance with Standard Drawing D-714-25, D-714-25M, D-714-26 or D-714-26M.

Pipe sections deemed unsalvageable will be replaced at the discretion of the field Engineer. Discretionary quantities of 100 LF of Pipe Conc Reinf 24 IN, 50 LF of Pipe Conc Reinf 30 IN, 50 LF of Pipe Conc Reinf 36 IN and 1000 SY of Geotextile Fabric – Type R1 have been provided in the plans. Payment for replacing unsalvageable pipe will be included in the price bid for "Pipe Conc Reinf _In CL III".

714-P02 REMOVE & RELAY PIPE-ALL TYPES & SIZES: Include all costs associated with removing and relaying the existing 48" RCP T-Section, 24" RCP riser and existing pipe sections at Sta 305+44 (RC_42_N_SER) in the bid price for "Remove & Relay Pipe-All Types & Sizes".

714-P03 PVC PIPE: Provide PVC pipe material that meets the requirements of Section 830.03 A.3.

722-P01 RELAY PRECAST CONCRETE MEDIAN DRAIN: Include all costs associated with relaying and installing the precast concrete median drain at Sta 305+44 (RC_42_N_SER) in the bid price for "Relay Precast Concrete Median Drain".

722-P02 CASTING MOUNTABLE CURB-TYPE A: Remove and replace existing inlet castings at designated locations on grade separations with a new Type A mountable curb casting and grates. Include all costs for removal and disposal of the existing curb inlet castings and grates, and for furnishing and installing the new mountable Type A castings and grates in the price bid for the item "Casting Mountable Curb - Type A."

748-P01 CURB & GUTTER – TYPE 1 SPECIAL: Fifteen lineal feet of curb and gutter is required along each side of the roadway at the ends of the bridge approach slabs, at the Christine Interchange Crossroad, RP 44.126. The curb and gutter shall be Type 1 as shown on Standard Drawing D-748-1, except the last 2 feet of curb and gutter, at the end nearest the approach slab, will be transitioned to match the shape of the single slope barrier and the end

of the curb furthest from the bridge approach slab shall be tapered from a 6" curb height to 0" curb height in 3 feet, as shown on Standard Drawing D-764-60. All costs for constructing the curb and gutter as described above, shall be included in the price bid for "Curb & Gutter – Type 1 Special."

754-P01 DELINEATOR: Approximately 7 delineator posts may need to be removed to accommodate the temporary ramp connections on this project. Include all cost to remove and reset any delineator posts in the price bid for other items. After northbound and southbound traffic has been restored, stockpile delineators required for head to head traffic at the rest area at Sta 2160+00 Lt for the future northbound reconstruction project.

754-P02 REMOVED CONCRETE FOUNDATIONS: Remove existing concrete foundations or obliterate to a minimum 3-foot depth below proposed finished grade.

754-P03 REMOVED SIGNING: Remove and dispose of all existing telescoping perforated tube, w-shape post supports, yellow faced signs and extruded aluminum sign panels. Deliver the existing round pipe supports to the Fargo District sign shop at 503 38th St South, Fargo. Contact the Fargo District sign shop 24 hours prior to delivery at (701) 239-8900. Include all costs associated with the removal and delivery of the sign panels and supports in the price bid for the item "Remove Sign Foundation".

762-050 PAVEMENT MARKING: If the Engineer and Contractor agree, plan quantity will be used as the measurement for payment for pavement marking items.

762-P01 RAISED PAVEMENT MARKERS: Place raised pavement markers on the centerline of the two-lane two-way roadway. Place the markers in pairs, 4 inches apart, spaced at 5 feet along the centerline. Place raised pavement markers on the median crossovers and ramp connections at 5' spacings. Place the markers as per Standard Drawings 704-38 & 704-39 and as per Section 100. Provide Stimsonite No. 66, Flex-O-Lite, RCM construction marker, or equal. Clean the raised pavement markers when necessary to retain reflectivity. At completion of the project, remove the markers in accordance with the manufacturer's recommendations and when removed, take care to have the adhesive pad removed down as close as possible to the pavement using a mechanical scraper such as a loader-type machine with a bucket. The raised pavement markers will be measured by the number complete in place and accepted by the Engineer.

Include the cost of furnishing, installing, maintaining, and removing in the price bid for "Raised Pavement Markers."

764-P01 W-BEAM GUARDRAIL: The W-beam guardrail materials on SB I29 at the Pitcarin Creek Bridge, Wild Rice River Bridge and the Christine Interchange Bridge are scheduled to be removed and reset under phase 3 of the traffic control phasing plan. Reset an assumed 75% of existing guardrail as directed by the Engineer. Deliver the remaining guardrail materials deemed salvageable by the Engineer to the NDDOT Maintenance Storage Yard located at 503 38th St South, Fargo and neatly stack at the location in the storage yard. Notify the NDDOT Maintenance Storage Yard 24 hours prior to delivery at (701) 239-8900. Include all costs to remove and deliver temporary guardrail material in the price bid for the removal of guardrail items. Quantities for the End Treatment & Transition and the additional W-Beam Guardrail have been provided.

This document was originally issued and sealed by Matt Lange, Registration Number PE- 6870, on 08/07/17 and the original document is stored at the North Dakota Department of Transportation

NOTES

STATE	PROJECT NO.	SECTION NO.	SHEET NO.
ND	IM-8-029(170)033	6	6

764-P02 W-BEAM GUARDRAIL END TERMINALS FOR TWO-WAY TRAFFIC: The W-beam guardrail end terminals and additional guardrail materials required for two-way traffic are scheduled to be removed under phase 4 and 5 of the traffic control phasing plan. Delivered the guardrail materials to the NDDOT Maintenance Storage Yard located at 503 38th St South, Fargo and neatly stack at the location in the storage yard. Notify the NDDOT Maintenance Storage Yard 24 hours prior to delivery at (701) 239-8900.

The W-beam guardrail end terminals will be measured and paid for by the number of W-beam guardrail end terminals required and accepted by the engineer. Include all costs associated with materials, including W-Beam terminal connector and W-beam rail sections, and all necessary posts, blocks, hardware, equipment, and labor in the unit price bid for "W-Beam Guardrail End Terminal". Include all costs to remove and deliver temporary guardrail material in the price bid for "W-Beam Guardrail End Terminal".

764-P03 REMOVE CONCRETE SAFETY SHAPE TRANSITION: This item consists of removing the concrete safety shape transitions at the corners of the Christine Interchange, RP 44.126. Each safety shape transition is 13'-7" in length and is constructed of approximately 2.1 cubic yards of reinforced concrete. The bottom of the safety shape transitions is approximately 2 feet below the finished surface. Saw cutting may be required to separate the safety shape transitions from the adjacent concrete bridge barrier that is to remain in place. The removed safety shape transitions is the property of the contractor. Repair any damage to the bridge ends that are to remain in place resulting from removal of the concrete safety shape transitions. Include costs to repair any damage in the unit price bid for "Remove Concrete Safety Shape". The item "Remove Concrete Safety Shape Transition" will be paid for by the number of safety shape transitions removed.

764-P04 GUARDRAIL EMBANKMENT: The embankment material required for guardrail installation may be obtained from the excess material removed from the I-29 grading, with the approval of the Engineer.

990-P01 PIPE CLEANOUT: Remove any silt or debris encountered in the centerline culverts. A discretionary quantity of 12 EA has been provided in the plans. Include costs associated with removing the silt or debris in the price bid for "Pipe Cleanout".

This document was originally issued and sealed by
Matt Lange,
Registration Number
PE- 6870,
on 08/07/17 and the original document is stored at the
North Dakota Department
of Transportation

ENVIRONMENTAL NOTES

STATE	PROJECT NO.	SECTION NO.	SHEET NO.
ND	IM-8-029(170)033	6	7

ENVIRONMENTAL NOTES (EN): The North Dakota Department of Transportation and the Federal Highway Administration have made environmental commitments to secure approval of this project. The following environmental notes are requirements to comply with these commitments:

EN-1 SPAWNING RESTRICTION: Do not work within the Wild Rice River from April 15 to June 1.

EN-2 WHOOPING CRANE: Stop all construction activities and notify the Engineer immediately in the event a whooping crane is identified within one mile of the project location. The Engineer will then coordinate with the USFWS, FHWA and NDDOT. Do not resume work within the avoidance area until the Engineer has confirmed that the bird has left the area.

Above ground utility conflicts are not foreseen with this project but if any impacts are required, contact the NDDOT Utility Engineer to coordinate with the utility company. Bird diverters will be installed by the utility company on overhead utility lines that are shifted due to the proposed action.

EN-3 TEMPORARY WETLAND IMPACT: Temporary impact areas within wetlands and or other waters are incorporated into the plans for this project. Remove temporary fill placed and sedimentation in wetlands or other waters. Restore these wetlands to preconstruction contours.

EN-4 AQUATIC NUISANCE SPECIES (ANS): Equipment that was last used outside of North Dakota or within a Class I infested waterbody (identified on the North Dakota Game and Fish Department (NDGFD) website) requires an inspection by NDGFD. Notify the NDGFD at least 10 business days prior to pumps, watercraft, or any equipment entering a public water to allow the NDGFD sufficient time to inspect any and all such equipment for ANS. Contact the NDGFD ANS Coordinator, Jessica Howell by e-mail jmhowell@nd.gov for equipment inspections. Supply one of the following to the engineer as proof of compliance prior to work taking place in the water: (1) the NDGFD inspection report, (2) documented NDGFD correspondence (email or signed letter). If an inspection is not required, no follow up documentation is required.

This document was originally issued and sealed by
Matt Lange,
Registration Number
PE- 6870,
on 08/07/17 and the original document is stored at the
North Dakota Department
of Transportation

ESTIMATE OF QUANTITIES

SPEC	CODE	ITEM DESCRIPTION	UNIT	TOTAL
103	0100	CONTRACT BOND	L SUM	1
201	0330	CLEARING & GRUBBING	L SUM	1
202	0101	REMOVAL OF CONCRETE	EA	1
202	0111	REMOVAL OF CONCRETE	L SUM	1
202	0113	REMOVAL OF CONCRETE	CY	73.8
202	0130	REMOVAL OF CURB & GUTTER	LF	560
202	0132	REMOVAL OF BITUMINOUS SURFACING	SY	15,024
202	0136	REMOVAL OF PAVEMENT	TON	133,454
202	0169	REMOVAL OF END SECTION-ALL TYPES & SIZES	EA	58
202	0174	REMOVAL OF PIPE ALL TYPES AND SIZES	LF	332
202	0237	REMOVAL OF MEDIAN DRAIN PRECAST CONCRETE	EA	1
202	0312	REMOVE EXISTING FENCE	LF	9,139
202	0350	REMOVAL OF TEMPORARY BYPASS	EA	5
203	0109	TOPSOIL	CY	75,173
203	0138	COMMON EXCAVATION-SUBCUT	CY	1,561
203	0218	GUARDRAIL EMBANKMENT	EA	10
210	0051	BOX CULVERT EXCAVATION - SITE 1	EA	1
210	0052	BOX CULVERT EXCAVATION - SITE 2	EA	1
210	0210	FOUNDATION FILL	CY	30
210	0405	FOUNDATION PREPARATION-BOX CULVERT	EA	1
216	0100	WATER	M GAL	3,453
220	0100	PREPARE STOCKPILE SITE	L SUM	1
220	0200	RESTORE STOCKPILE SITE	L SUM	1
230	0106	RESHAPING ROADWAY	MILE	12.22
230	0320	SUBGRADE PREPARATION-TYPE C-12IN	STA	557
251	0200	SEEDING CLASS II	ACRE	109.8
251	2000	TEMPORARY COVER CROP	ACRE	108.7
253	0201	HYDRAULIC MULCH	ACRE	218.5
255	0103	ECB TYPE 3	SY	2,242
255	0202	TRM TYPE 2	SY	838
256	0100	RIPRAP GRADE I	CY	21
256	0200	RIPRAP GRADE II	CY	30
260	0200	SILT FENCE SUPPORTED	LF	2,135
260	0201	REMOVE SILT FENCE SUPPORTED	LF	2,135
261	0112	FIBER ROLLS 12IN	LF	155,954
261	0113	REMOVE FIBER ROLLS 12IN	LF	77,716
302	0100	SALVAGED BASE COURSE	TON	101,389
401	0050	TACK COAT	GAL	1,896
401	0060	PRIME COAT	GAL	4,761
411	0105	MILLING PAVEMENT SURFACE	SY	14,221
430	0040	SUPERPAVE FAA 40	TON	6,035
430	2000	PATCHING	TON	500
430	5803	PG 58S-28 ASPHALT CEMENT	TON	363
550	0302	8.5IN NON-REINF CONCRETE PVMT CL AE-DOWELED	SY	200,872
570	0966	RANDOM PCC CRACK CLEANING & SEALING	LF	249
602	0130	CLASS AAE-3 CONCRETE	CY	269.6
602	1131	CLASS AE-3 CONCRETE-BOX CULVERT	CY	48.9
602	1133	CONCRETE BRIDGE APPROACH SLAB	SY	144.4
602	1135	BRIDGE APPROACH SLAB-REMOVE & REPLACE	SY	364.4
602	1250	PENETRATING WATER REPELLENT TREATMENT	SY	783
612	0114	REINFORCING STEEL-GRADE 60-BOX CULVERT	LBS	9,392
612	0115	REINFORCING STEEL-GRADE 60	LBS	1,204
612	0116	REINFORCING STEEL-GRADE 60-EPOXY COATED	LBS	68,764
624	3002	DOUBLE BOX BEAM RAIL RETROFIT - E-RAIL	LF	1,441.7
702	0100	MOBILIZATION	L SUM	1
704	0100	FLAGGING	MHR	3,250
704	1000	TRAFFIC CONTROL SIGNS	UNIT	14,096
704	1045	ATTENUATION DEVICE-TYPE B-75	EA	2
704	1052	TYPE III BARRICADE	EA	63
704	1060	DELINEATOR DRUMS	EA	514
704	1067	TUBULAR MARKERS	EA	1,649
704	1070	DELINEATOR	EA	460
704	1072	FLEXIBLE DELINEATORS	EA	864
704	1080	STACKABLE VERTICAL PANELS	EA	166
704	1081	VERTICAL PANELS-BACK TO BACK	EA	12
704	1087	SEQUENCING ARROW PANEL-TYPE C	EA	2
704	1088	SEQUENCING ARROW PANEL-TYPE C-CROSSOVER	EA	2
704	1090	FLASHING BEACON	EA	2
704	1500	OBLITERATION OF PAVEMENT MARKING	SF	6,965
704	3510	PRECAST CONCRETE MED BARRIER-STATE FURNISHED	EA	79
706	0400	FIELD OFFICE	EA	1
706	0500	AGGREGATE LABORATORY	EA	1
706	0600	CONTRACTOR'S LABORATORY	EA	1
709	0100	GEOSYNTHETIC MATERIAL TYPE G	SY	17,904
709	0151	GEOSYNTHETIC MATERIAL TYPE R1	SY	4,298
709	0155	GEOSYNTHETIC MATERIAL TYPE RR	SY	112
714	0615	PIPE CONC REINF 24IN CL III	LF	194
714	0820	PIPE CONC REINF 30IN CL III	LF	56
714	0905	PIPE CONC REINF 36IN CL III	LF	80

ESTIMATE OF QUANTITIES

SPEC	CODE	ITEM DESCRIPTION	UNIT	TOTAL
714	1005	PIPE CONC REINF 42IN CL III	LF	6
714	3020	END SECT-CONC REINF 24IN	EA	18
714	3023	END SECT-TRAVERSABLE REINF. CONC.24IN	EA	11
714	3030	END SECT-CONC REINF 30IN	EA	4
714	3033	END SECT-TRAVERSABLE REINF. CONC.30IN	EA	3
714	3035	END SECT-CONC REINF 36IN	EA	13
714	3036	END SECT-TRAVERSABLE REINF. CONC.36IN	EA	1
714	3040	END SECT-CONC REINF 42IN	EA	1
714	3045	END SECT-CONC REINF 48IN	EA	1
714	4122	PIPE CONDUIT 42IN-APPROACH	LF	144
714	7030	PIPE PVC 12IN	LF	311
714	9659	REMOVE & RELAY PIPE-ALL TYPES & SIZES	LF	1,960
714	9660	REMOVE & RELAY END SECTION-ALL TYPE & SIZES	EA	2
714	9900	INSTALL CONCRETE PIPE TIES	SET	298
714	9917	FLAP GATE 42IN	EA	3
720	0125	ALIGNMENT MONUMENTS	EA	1
720	0135	IRON PIN REFERENCE MONUMENTS	EA	11
722	3485	CASTING MOUNTABLE CURB-TYPE A	EA	12
722	4581	RELAY PRECAST CONCRETE MEDIAN DRAIN	EA	1
748	0141	CURB & GUTTER-TYPE 1 SPECIAL	LF	60
748	0150	MOUNTABLE CURB & GUTTER-TYPE 1 SEC A	LF	480
752	0700	FENCE WOVEN WIRE	LF	9,139
752	0993	FENCE TERMINAL	EA	7
752	3120	CORNER ASSEMBLY WOVEN WIRE	EA	10
752	4120	DOUBLE BRACE ASSEMBLY WOVEN WIRE	EA	2
754	0110	FLAT SHEET FOR SIGNS-TYPE XI REFL SHEETING	SF	50
754	0112	FLAT SHEET FOR SIGNS-TYPE IV REFL SHEETING	SF	59
754	0195	DIAMOND GRADE DELINEATORS-TYPE A	EA	141
754	0196	DIAMOND GRADE DELINEATORS-TYPE B	EA	64
754	0198	DIAMOND GRADE DELINEATORS-TYPE D	EA	18
754	0199	DIAMOND GRADE DELINEATORS-TYPE E	EA	2
754	0210	GALV STEEL POST-STANDARD PIPE	LF	139
754	0214	GALV STEEL POSTS-W-SHAPE POSTS(TWO OR MORE)	LF	692
754	0534	PANEL FOR SIGNS-TYPE IV REFLECTIVE SHEETING	SF	1,116
754	0556	INTERSTATE MILE POSTS-TYPE B	EA	11
754	0801	OBJECT MARKERS - TYPE I	EA	3
754	0805	OBJECT MARKERS - CULVERTS	EA	69
754	1100	CLASS AE CONCRETE-SIGN FOUNDATIONS	CY	3.1
754	1104	REMOVE SIGN FOUNDATION	EA	23
754	1220	REMOVE OVERHEAD SIGN STR BRIDGE MOUNTED	EA	1
760	0001	RUMBLE STRIPS - CONCRETE SHOULDER	MILE	20.84
762	0103	PVMT MK PAINTED-MESSAGE	SF	82.5
762	0200	RAISED PAVEMENT MARKERS	EA	28,092
762	0430	SHORT TERM 4IN LINE-TYPE NR	LF	76,271
762	1104	PVMT MK PAINTED 4IN LINE	LF	225,111
762	1108	PVMT MK PAINTED 8IN LINE	LF	2,518
762	1124	PVMT MK PAINTED 24IN LINE	LF	130
764	0131	W-BEAM GUARDRAIL	LF	1,164
764	0145	W-BEAM GUARDRAIL END TERMINAL	EA	24
764	0151	REMOVE W-BEAM GUARDRAIL & POSTS	LF	1,908
764	1050	RESET W-BEAM GUARDRAIL	LF	800
764	1990	REMOVE CONCRETE SAFETY SHAPE TRANSITION	EA	4
764	2081	REMOVE END TREATMENT & TRANSITION	EA	20
990	0400	PIPE CLEANOUT	EA	12

ALTERNATE A: CONCRETE SHOULDERS

SPEC	CODE	ITEM DESCRIPTION	UNIT	TOTAL
216	0100	WATER	M GAL	609
302	0100	SALVAGED BASE COURSE	TON	30,453
550	0105	6IN NON-REINF CONCRETE PAVEMENT CL AE	SY	42,786

ALTERNATE B: CONCRETE MEDIAN SHOULDER W/ 8' ASPHALT OUTSIDE SHOULDER

SPEC	CODE	ITEM DESCRIPTION	UNIT	TOTAL
216	0100	WATER	M GAL	785
302	0100	SALVAGED BASE COURSE	TON	39,244
401	0050	TACK COAT	GAL	2,220
401	0060	PRIME COAT	GAL	12,034
430	0040	SUPERPAVE FAA 40	TON	9,877
430	1000	CORED SAMPLE	EA	109
430	5803	PG 58S-28 ASPHALT CEMENT	TON	594
706	0550	BITUMINOUS LABORATORY	EA	1

I-29 - N of Galchutt Exit to Christine Exit
Estimate of Quantities

PAVING SUMMARY: I-29 SOUTHBOUND												
Chain	Begin Station	End Station	Length (LF)	Area (Plan View or Cross Section)			302 0100 SALVAGED BASE COURSE (TON)	401 0050 TACK COAT (GAL)	401 0060 PRIME COAT (GAL)	430 0040 SUPERPAVE FAA 40 (TON)	430 5803 PG 58S-28 ASPHALT CEMENT (TON)	550 0302 8.5IN NON-REINF CONCRETE PVMT CL AE-DOWELED (SY)
				Salvaged Base (SF)	PCC (SF)	HMA (SF)						
MAINLINE (14' LEFT + 16' RIGHT = 30' WIDTH)												
SCL29	1764+76	1813+25	4,849	21.46	145,470		7,226					16,163
	1814+36	2197+40	38,304	21.46	1,149,120		57,084					127,680
	2200+24	2326+00	12,576	21.46	377,280		18,742					41,920
SUBTOTAL =			55,729			83,052	-	-	-	-	-	185,763
RAMP TAPERS												
SCL29	1933+60	1945+91	1,231	24,542	21,842		1,136					2,427
	1965+05	1973+90	885	17,273	15,333		800					1,704
	2138+27	2150+58	1,231	24,562	21,858		1,137					2,429
	2163+42	2172+27	885	17,273	15,333		800					1,704
	2201+87	2214+17	1,230	25,664	22,790		1,188					2,532
	2233+30	2242+31	901	19,150	16,976		887					1,886
2308+70	2321+01	1,231	24,542	21,842		1,136					2,427	
SUBTOTAL =			7,594	153,006	135,974	7,084	-	-	-	-	-	15,109
GUARDRAIL GRADING												
SCL29	1814+16	1817+97	381	11,874		8,264	412		330	102	6	
	2200+04	2203+85	381	11,874		8,264	412		330	102	6	
SUBTOTAL =			762			824	-	660	204	12	-	
MEDIAN CROSSOVER CONNECTION												
SCL29	1764+76	1770+81	605			1,225			7	64	4	
SUBTOTAL =			605			-		7	64	4	-	
GRAND TOTAL =			-	-	-	90,960	7	660	268	16	200,872	

Water
25 M Gal/Mile for Dust Palliative
25 M Gal/Mile for Subgrade Preparation
20 Gal/Ton for Aggregate
10 Gal/CY for Embankment

Pavement
Salvaged Base Course @ 1.875 Ton/CY
Tack Coat @ 0.05 Gal/SY
Prime Coat @ 0.25 Gal/SY
PG 58S-28 Asphalt Cement @ 6.0% by Weight
Superpave FAA 40 @ 2 Ton/CY

Removals
Aggregate Base @ 1.875 Ton/CY
Hot Mix Asphalt @ 2 Ton/CY
Concrete Pavement @ 2 Ton/CY

PAVING SUMMARY: I-29 SOUTHBOUND SHOULDER ALTERNATES												
Chain	Begin Station	End Station	Length (SF)	Area (Plan View or Cross Section)			302 0100 SALVAGED BASE COURSE (TON)	401 0050 TACK COAT (GAL)	401 0060 PRIME COAT (GAL)	430 0040 SUPERPAVE FAA 40 (TON)	430 5803 PG 58S-28 ASPHALT CEMENT (TON)	550 0105 6IN NON-REINF CONCRETE PVMT CL AE (SY)
				Salvaged Base (SF)	PCC (SF)	HMA (SF)						
ALTERNATE A (PCC OUTSIDE SHOULDER - 8' WIDTH)												
SCL29	1764+76	1813+25	4,849	9.11	38,792		3,068					4,310
	1814+36	1933+60	11,924	9.11	95,392		7,544					10,599
	1945+91	1965+05	1,914	9.11	15,312		1,211					1,701
	1973+90	2138+27	16,437	9.11	131,496		10,399					14,611
	2150+58	2163+42	1,284	9.11	10,272		812					1,141
	2172+27	2197+40	2,513	9.11	20,104		1,590					2,234
	2200+24	2201+87	163	9.11	1,304		103					145
	2214+17	2233+30	1,913	9.11	15,304		1,210					1,700
	2242+31	2308+70	6,639	9.11	53,112		4,200					5,901
2321+01	2326+00	499	9.11	3,992		316					444	
SUBTOTAL =			48,135		385,080	30,453	-	-	-	-	-	42,786
ALTERNATE B (HMA OUTSIDE SHOULDER - 8' WIDTH)												
SCL29	1764+76	1813+25	4,849	11.74		2.77	3,953	224	1,212	995	60	
	1814+36	1933+60	11,924	11.74		2.77	9,721	550	2,981	2,447	147	
	1945+91	1965+05	1,914	11.74		2.77	1,560	88	479	393	24	
	1973+90	2138+27	16,437	11.74		2.77	13,401	758	4,109	3,373	202	
	2150+58	2163+42	1,284	11.74		2.77	1,047	59	321	263	16	
	2172+27	2197+40	2,513	11.74		2.77	2,049	116	628	516	31	
	2200+24	2201+87	163	11.74		2.77	133	8	41	33	2	
	2214+17	2233+30	1,913	11.74		2.77	1,560	88	478	393	24	
	2242+31	2308+70	6,639	11.74		2.77	5,413	306	1,660	1,362	82	
2321+01	2326+00	499	11.74		2.77	407	23	125	102	6		
SUBTOTAL =			48,135			39,244	2,220	12,034	9,877	594	-	
GRAND TOTAL =			-	-	-	30,453 - 39,244	0 - 2,220	0 - 12,034	0 - 9,877	0 - 594	0 - 42,786	

This document was originally issued and sealed by Jonathan D. Bach, Registration Number PE- 9797, on 08/07/17 and the original document is stored at the North Dakota Department of Transportation

I-29 - N of Galchutt Exit to Christine Exit
Basis of Estimate

STATE	PROJECT NO.	SECTION NO.	SHEET NO.
ND	IM-8-029(170)033	10	2

PAVING SUMMARY: RAMPS & INTERCHANGES							
Chain	Begin Station	End Station	Area (Plan View)		401 0050 TACK COAT (GAL)	430 0040 SUPERPAVE FAA 40 (TON)	430 5803 PG 58S-28 ASPHALT CEMENT (TON)
			HMA	HMA Thickness (IN)			
			(SF)	(IN)			
COLFAX INTERCHANGE (RP 37,043)							
EXCOLSWR	12+29	22+23	12,006	4	133	296	18
			15,822	2	88	195	12
EXCOLFAX	7+60	13+83	31,503	2	175	389	23
EXCOLNWR	1+13	10+82	10,944	4	122	270	16
			15,624	2	87	193	12
SUBTOTAL =			85,899	-	605	1,343	81
WALCOTT INTERCHANGE (RP 42,169)							
EX60SWR	12+68	21+61	10,740	2	60	133	8
EX60ST	17+60	23+81	25,653	2	143	317	19
EX60NWR	0+92	11+05	11,574	2	64	143	9
SUBTOTAL =			47,967	-	267	593	36
CHRISTINE INTERCHANGE (RP 44,126)							
EX58ST	10+62	16+64	21,148	2	117	261	16
	19+39	25+42	20,957	2	116	259	16
SUBTOTAL =			42,105	-	233	520	32
GRAND TOTAL =			175,971	-	1,105	2,456	149

PAVING SUMMARY: GRADE SEPARATIONS GUARDRAIL GRADING								
Chain	Begin Station	End Station	Area (Plan View)		302 0100 SALVAGED BASE COURSE (TON)	401 0050 TACK COAT (GAL)	430 0040 SUPERPAVE FAA 40 (TON)	430 5803 PG 58S-28 ASPHALT CEMENT (TON)
			Salvaged Base	HMA				
			(SF)	(SF)				
PITCAIRN SEPARATION (RP 34,040)								
EX68ST	12+01	13+82	2,338	1,667	81	9	21	1
	16+17	17+99	2,338	1,667	81	9	21	1
SUBTOTAL =			4,676	3,334	162	18	42	2
COLFAX SEPARATION (RP 39,047)								
EX63ST	12+01	13+83	2,338	1,667	81	9	21	1
	16+18	17+99	2,338	1,667	81	9	21	1
SUBTOTAL =			4,676	3,334	162	18	42	2
MILE 41 SEPARATION (RP 41,053)								
EX61ST	14+48	16+63	2,820	2,075	98	12	26	2
	19+08	21+22	2,820	2,075	98	12	26	2
SUBTOTAL =			5,640	4,150	196	24	52	4
CHRISTINE INTERCHANGE (RP 44,126)								
EX58ST	15+06	16+64	2,132	1,558	74	9	19	1
	19+39	20+98	2,132	1,558	74	9	19	1
SUBTOTAL =			4,264	3,116	148	18	38	2
GRAND TOTAL =			19,256	13,934	668	78	174	10

PAVING SUMMARY: PROPOSED TEMPORARY RAMP CONNECTIONS											
Chain	Begin Station	End Station	Area (Plan View)			302 0100 SALVAGED BASE COURSE (TON)	401 0050 TACK COAT (GAL)	401 0060 PRIME COAT (GAL)	430 0040 SUPERPAVE FAA 40 (TON)	430 5803 PG 58S-28 ASPHALT CEMENT (TON)	709 0100 GEOSYNTHETIC MATERIAL TYPE G (SY)
			Salvaged Base	HMA	Geosynthetic Material						
			(SF)	(SF)	(SF)						
COLFAX INTERCHANGE (RP 37,043)											
RC_37_N_SER	100+00	111+49	18,336	15,585	20,170	849	87	509	385	23	2,241
	112+04	115+76	8,183	7,223	8,824	379	40	227	178	11	980
RC_37_N_NER	201+36	205+15	8,061	7,044	8,739	373	39	224	174	10	971
	205+71	220+94	25,053	21,497	27,424	1,160	119	696	531	32	3,047
SUBTOTAL =			59,633	51,349	65,157	2,761	285	1,656	1,268	76	7,239
WALCOTT INTERCHANGE (RP 42,169)											
RC_42_N_SER	300+00	311+50	18,350	15,596	20,186	850	87	510	385	23	2,243
	312+04	315+86	8,500	7,501	9,166	394	42	236	185	11	1,018
RC_42_N_NER	401+27	405+83	10,071	8,783	10,929	466	49	280	217	13	1,214
	406+35	421+34	24,554	21,092	26,863	1,137	117	682	521	31	2,985
SUBTOTAL =			61,475	52,972	67,144	2,847	295	1,708	1,308	78	7,460
CHRISTINE INTERCHANGE (RP 44,126)											
RC_44_N_SER	500+00	511+50	18,346	15,594	19,971	849	87	510	385	23	2,219
	512+04	516+05	8,167	7,109	8,872	378	39	227	176	11	986
SUBTOTAL =			26,513	22,703	28,843	1,227	126	737	561	34	3,205
GRAND TOTAL =			147,621	127,024	161,144	6,835	706	4,101	3,137	188	17,904

230 0320 SUBGRADE PREPARATION-TYPE C-12IN			
Begin Station	End Station	Basis	Quantity (STA)
I-29 SOUTHBOUND			
1764+76	1813+25	100 LF/Sta	48
1814+36	2197+40	100 LF/Sta	383
2200+24	2326+00	100 LF/Sta	126
TOTAL =			557

This document was originally issued and sealed by Jonathan D. Bach, Registration Number PE- 9797, on 08/11/17 and the original document is stored at the North Dakota Department of Transportation

I-29 - N of Galchutt Exit to Christine Exit
Basis of Estimate

STATE	PROJECT NO.	SECTION NO.	SHEET NO.
ND	IM-8-029(170)033	10	3

754 0805 OBJECT MARKERS - CULVERTS		
Station	Alignment	Quantity (EA)
I-29 SOUTHBOUND		
1849+74		2
1902+78		2
1950+72		2
1950+84		2
2006+91		2
2007+38		2
2058+76		2
2108+94		2
2123+92		2
2138+94		2
2156+91		2
2166+93		1
2173+94	Interstate Median (SCL29)	2
2189+93		2
2209+92		2
2219+91		2
2229+91		2
2245+90		1
2254+91		2
2277+90		2
2290+30		2
2299+20		1
2299+40		1
2312+32		2
2324+31		2
2325+80		1
COLFAX INTERCHANGE (RP 37.043)		
17+03	EXCOLSWR	2
17+11		2
8+13	EXCOLFAX	2
8+25		2
6+26	EXCOLNWR	2
63RD STREET SOUTHEAST (RP 39.047)		
2060+34	Interstate Median (SCL29)	1
2062+44		1
WALCOTT INTERCHANGE (RP 42.169)		
15+48	EX60SWR	2
8+13	EX60NWR	2
12+03	EX60SER	2
6+88	EX60NER	2
CHRISTINE INTERCHANGE (RP 44.126)		
17+29	EX58SWR	2
TOTAL = 69		

714 9900 INSTALL CONCRETE PIPE TIES			
Station	Alignment	Diameter (IN)	Quantity (SET)
I-29 SOUTHBOUND			
1849+74		30	12
1902+78		24	11
1950+72		36	11
1950+84		36	11
2058+76		36	11
2108+94		24	13
2123+92		30	16
2138+94		30	14
2156+91		24	12
2166+93		36	14
2173+94		24	13
2189+93	Interstate Median (SCL29)	24	12
2209+92		48	14
2219+91		24	12
2229+91		24	12
2245+90		42	14
2254+91		24	12
2277+90		24	11
2290+30		24	12
2299+20		36	12
2299+40		36	12
2312+32		24	12
2324+31		24	12
2325+80		36	13
TOTAL = 298			

754 0195 DIAMOND GRADE DELINEATORS-TYPE A				
Begin Station	End Station	Basis	Color	Quantity (EA)
I-29 SOUTHBOUND - OUTSIDE SHOULDER¹				
1764+76	2068+46	1 EA / 528 LF	White	58
2068+46	2091+05	1 EA / 264 LF		9
2091+05	2101+16	1 EA / 528 LF		2
2101+16	2140+13	1 EA / 264 LF		15
2140+13	2233+89	1 EA / 528 LF		18
2233+89	2252+13	1 EA / 264 LF		7
2252+13	2326+00	1 EA / 528 LF		14
RAMPS - EXISTING RAMP CONNECTIONS⁴				
Sta 14+15 (EXCOLSWR)		1 EA	Yellow	1
Sta 16+12 (EXCOLSWR)		1 EA		1
Sta 6+98 (EXCOLNWR)		1 EA		1
Sta 8+75 (EXCOLNWR)		1 EA		1
Sta 16+17 (EX60SWR)		1 EA		1
Sta 18+16 (EX60SWR)		1 EA		1
Sta 7+53 (EX60NWR)		1 EA		1
Sta 9+54 (EX60NWR)		1 EA		1
Sta 14+11 (EX58SWR)		1 EA		1
Sta 16+10 (EX58SWR)		1 EA		1
TOTAL =				133

- Notes:
1) Refer to Standard Drawing D-754-21
2) Refer to Standard Drawing D-754-22A
3) Refer to Standard Drawing D-754-22B
4) To replace ramp delineators after removal of existing southbound ramp connections.
5) Refer to Section 110 for proposed delineators on interstate ramps.

430 1000 CORED SAMPLE (ALTERNATE B - HMA OUTSIDE SHOULDER - 8' WIDTH)										
Chain	Begin Station	End Station	Specification Section	A	B	C	D	Quantity (D x 2)	Quantity (1 per mile)	Unit
				Distance (Ft) /2000	Lanes	Lifts	Sublots (A x B x C)			
SCL29	1764+76	1813+25	430.04 I.2.b(1), "General"	2	1	2	4	8	n/a	EA
	1814+36	1933+60		6	1	2	12	24		
	1945+91	1965+05		1	1	2	2	4		
	1973+90	2138+27		8	1	2	16	32		
	2150+58	2163+42		1	1	2	2	4		
	2172+27	2197+40		1	1	2	2	4		
	2200+24	2201+87		1	1	2	2	4		
	2214+17	2233+30		1	1	2	2	4		
	2242+31	2308+70		3	1	2	6	12		
	2321+01	2326+00		1	1	2	2	4		
SCL29	1764+76	1813+25	430.04 I.2.b(2), "Pavement Thickness Determination Cores"	-	-	-	-	-	9	EA
	1814+36	1933+60								
	1945+91	1965+05								
	1973+90	2138+27								
	2150+58	2163+42								
	2172+27	2197+40								
	2200+24	2201+87								
	2214+17	2233+30								
2242+31	2308+70									
2321+01	2326+00									
SUBTOTAL =								100	9	EA
GRAND TOTAL =								109		EA

SALVAGED PAVEMENT & BASE REMOVALS PER PHASE				
Pavement Type	Phase 1 & 2 (TON)	Phase 3 (TON)	Phase 4 (TON)	Phase 5 (TON)
Removal of Bituminous	No Removals	14,477	2,359	2,187
Removal of Concrete		118,638	-	-
Removal of Aggregate		339	4,423	1,572
Total Salvaged Material	-	133,454	6,782	3,759
Subtract 5% for Handling Loss	-	6,673	339	188
Available Salvaged Material	-	126,781	6,443	3,571
136,795				

- Notes:
1) Materials removed from the following work areas are not included in the above summary:
a) Triple RCB Extension (RP 38.039)
b) RCB Concrete Spillway Wall Repair (RP 40.033)
c) Christine Interchange Bridge Deck Replacement (RP 44.126)

SALVAGED BASE COURSE REQUIRED PER PHASE - ALTERNATE A (PCC OUTSIDE SHOULDER - 8' WIDTH)				
Pavement Type	Phase 1 & 2 (TON)	Phase 3 (TON)	Phase 4 (TON)	Phase 5 (TON)
Salvaged Base Course Required	0	121,413	4,845	2,658
Available Salvaged Material	0	126,781	11,811	10,537
Remaining Salvaged Material	0	5,368	6,966	7,879
Total Virgin Material Required	-	-	-	-

SALVAGED BASE COURSE REQUIRED PER PHASE - ALTERNATE B (HMA OUTSIDE SHOULDER - 8' WIDTH)				
Pavement Type	Phase 1 & 2 (TON)	Phase 3 (TON)	Phase 4 (TON)	Phase 5 (TON)
Salvaged Base Course Required	0	130,204	4,845	2,658
Available Salvaged Material	0	126,781	6,443	5,169
Remaining Salvaged Material	0	0	1,598	2,511
Total Virgin Material Required	-	3,423	-	-

This document was originally issued and sealed by Jonathan D. Bach, Registration Number PE- 9797, on 08/11/17 and the original document is stored at the North Dakota Department of Transportation

I-29 - N of Galchutt Exit to Christine Exit
Basis of Estimate

OBLITERATION, SHORT TERM, AND RAISED PAVEMENT MARKER SUMMARY										
Begin Station	End Station	704 1500 OBLITERATION OF PVMT MK			762 0200 RAISED PAVEMENT MARKERS		762 0430 SHORT TERM 4IN LINE-TYPE NR			
		Center Line Skips (SF)	Lt Edge Line (SF)	Rt Edge Line (SF)	Yellow (EA)	White (EA)	4IN White		4IN Yellow	
							Edge Line (LF)	Center Line (LF)	Edge Line (LF)	
SOUTH MEDIAN CROSSOVER (D-704-39)										
1760+38	1770+81	339			442	173				
I-29 NORTHBOUND										
1770+81	1932+00	1,343			6,448		16,119			
1932+00	1937+00	42	167		200		500			
1937+00	1971+50	288			1,380		3,450			
1971+50	1975+50	33	133		160		400			
1975+50	2201+02	1,879			9,020		22,552			
2201+02	2205+96	41	165		198		494			
2205+96	2239+84	282			1,356		3,388			
2239+84	2243+86	34	134		160		402			
2243+86	2307+39	529			2,542		6,353			
2307+39	2312+41	42	167		200		502			
2312+41	2357+71	378			1,812		4,530			
SUBTOTAL =		4,891	766		23,476		58,690			
I-29 SOUTHBOUND										
1945+63	1946+31			23						
1946+03	1946+65	5								
1946+39	1946+97		19							
1964+07	1964+64		19							
1964+38	1964+99	5								
1964+72	1965+37			22						
2214+21	2214+89			23						
2214+61	2215+23	5								
2214+97	2215+55		19							
2232+23	2232+82		20							
2232+55	2233+19	5								
2232+91	2233+60			23						
2320+74	2321+42			23						
2321+14	2321+76	5								
2321+50	2322+08		19							
SUBTOTAL =		25	96	114						
COLFAX INTERCHANGE (RP 37.043)										
SW Ramp & Connection				67	299	399	1,123		1,100	
Colfax Ave							936	922		
NW Ramp & Connection				68	248	328	1,106		1,080	
SUBTOTAL =				135	547	727	3,165	922	2,180	
WALCOTT INTERCHANGE (RP 42.169)										
SW Ramp & Connection				60	310	409	1,017		981	
60th Street Southeast							987	1,082		
NW Ramp & Connection				61	256	337	1,136		1,097	
SUBTOTAL =				121	566	746	3,140	1,082	2,078	
CHRISTINE INTERCHANGE (RP 44.126)										
SW Ramp				67	292	393				
58th Street Southeast							2,503	2,511		
SUBTOTAL =				67	292	393	2,503	2,511		
NORTH MEDIAN CROSSOVER (D-704-38)										
2357+71	2368+13	346			151	423				
2374+64	2382+44	65					156			
SUBTOTAL =		411			151	579				

Note:
See Section 100 for Grand Totals

PERMANENT PAVEMENT MARKING SUMMARY									
Begin Station	End Station	762 1104 PVMT MK PAINTED 4IN LINE					762 1108 PVMT MK PAINTED 8IN LINE	762 1124 PVMT MK PAINTED 24IN LINE	762 0103 PVMT MK PAINTED- MESSAGE*
		4IN White			4IN Yellow				
		Lt Edge Line (LF)	Center Line Skips (LF)	Rt Edge Line (LF)	Dotted Line (LF)	Rt Edge Line (LF)			
I-29 NORTHBOUND									
1727+99	1766+71			970					
1766+71	2361+88	59,517		14,880					
2361+88	2364+60			70					
SUBTOTAL =		59,517		15,920					
I-29 SOUTHBOUND									
1751+38	1760+38			230					
1760+38	1933+60	17,322		4,340		17,322			
1933+60	1945+91			310		1,231			
1945+91	1965+05	1,914		480		1,914			
1965+05	1973+90			230		885			
1973+90	2201+87	22,797		5,700		22,797			
2201+87	2214+17			310		1,230			
2214+17	2233+30	1,913		480		1,913			
2233+30	2242+31			230		901			
2242+31	2308+70	6,639		1,660		6,639			
2308+70	2321+01			310		1,231			
2321+01	2326+00	499		130		499			
2365+48	2368+13					265			
2366+63	2400+94			860					
SUBTOTAL =		51,084		15,270		56,827			82.5
COLFAX INTERCHANGE (RP 37.043)									
SW Ramp		2,352			260	1,100		390	
Colfax Ave		468		468			922		
NW Ramp		1,990			140	1,080		651	74
SUBTOTAL =		4,810		468	400	2,180	922	1,041	74
WALCOTT INTERCHANGE (RP 42.169)									
SW Ramp		2,285			260	1,021		390	
60th Street Southeast		490		497			1,082		
NW Ramp		2,076			138	1,148		697	56
SUBTOTAL =		4,851		497	398	2,169	1,082	1,087	56
CHRISTINE INTERCHANGE (RP 44.126)									
SW Ramp		2,350			260	1,092		390	
58th Street Southeast		1,256		1,247			2,511		
SUBTOTAL =		3,606		1,247	260	1,092	2,511	390	
GRAND TOTAL =		123,868	31,190	2,212	1,058	62,268	4,515	2,518	130
225,111									

*See Section 20 for details

760 0001 RUMBLE STRIPS - CONCRETE SHOULDER			
Begin Station	End Station	Basis	Quantity (MILE)
I-29 SOUTHBOUND - INSIDE SHOULDER			
1764+76	1813+25	5,280 LF/Mile	0.92
1817+97	2197+40		7.19
2203+85	2326+00		2.31
I-29 SOUTHBOUND - OUTSIDE SHOULDER			
1764+76	1813+25	5,280 LF/Mile	0.92
1817+97	2197+40		7.19
2203+85	2326+00		2.31
TOTAL =			20.84

This document was originally issued and sealed by Jonathan D. Bach, Registration Number PE- 9797, on 08/25/17 and the original document is stored at the North Dakota Department of Transportation

I-29 - N of Galchutt Exit to Christine Exit

Basis of Estimate

LOCATION	INTERSTATE 29 SOUTHBOUND - PHASE 3						TOPSOIL SUMMARY		
	EARTHWORK SUMMARY					230 0106 RESHAPING ROADWAY (Pay Item) ③		203 109 TOPSOIL	
	Excavation	Shoulder Alternate A		Shoulder Alternate B					230 0106 RESHAPING ROADWAY (Pay Item) ③
		Embankment ①	Excess Material	Embankment ①	Excess Material				
(CY)	(CY)	(CY)	(CY)	(CY)	(MILE)	(CY)			
A	B _{ALTA}	C _{ALTA} = A - B _{ALTA}	B _{ALT B}	C _{ALT B} = A - B _{ALT B}	D	E			
Interstate 29 - Southbound									
Sta 1764+76 to Sta 1813+25 (SCL29)									
Sta 1814+36 to Sta 2197+40 (SCL29)	85,556	8,791	76,765	8,791	76,765	10.57			
Sta 2200+24 to Sta 2326+00 (SCL29)									
Shoulder Alternate Embankment ②									
Alternate A: Slough Embankment		9,985	-9,985						
Alternate B: Slough Embankment				7,618	-7,618				
Waste Sites for Excess Material ④									
Sta 1952+00 Lt (SCL29): Colfax Interchange SW Gore Area		8,681	-8,681	8,989	-8,989	2,177			
Sta 1958+00 Lt (SCL29): Colfax Interchange NW Gore Area		10,017	-10,017	10,372	-10,372	2,571			
Sta 2220+00 Lt (SCL29): Walcott Interchange SW Gore Area		12,688	-12,688	13,138	-13,138	2,828			
Sta 2227+00 Lt (SCL29): Walcott Interchange NW Gore Area		12,688	-12,688	13,138	-13,138	3,053			
Sta 2326+00 Lt (SCL29): Christine Interchange SW Gore Area		10,017	-10,017	10,372	-10,372	2,545			
Sta 2332+00 Lt (SCL29): Christine Interchange SW Gore Area		12,689	-12,689	13,138	-13,138	3,688			
TOTAL (PHASE 3) =	85,556	85,556	0	85,556	0	10.57			

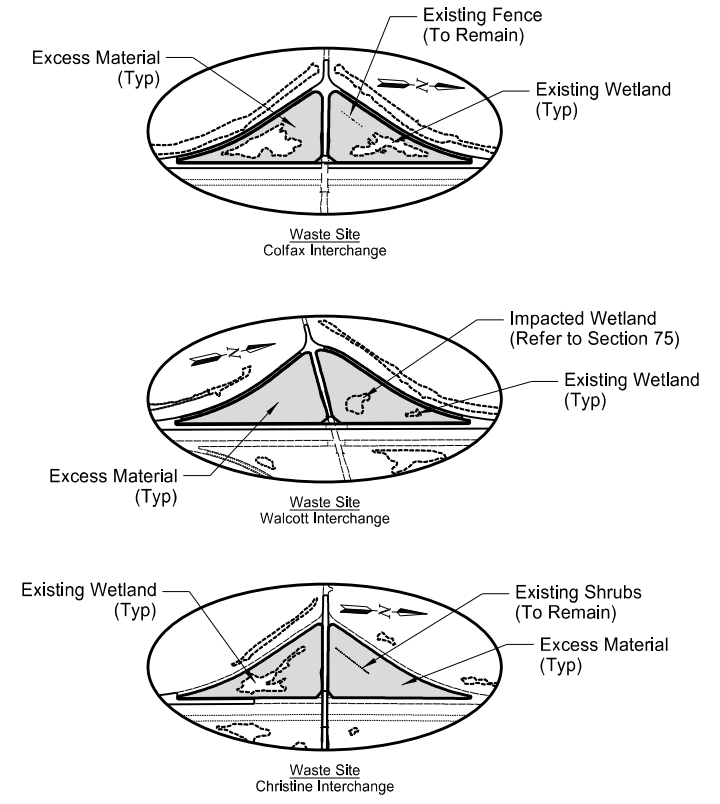

Notes:
 ① Additional 25% volume included for shrinkage
 ② Refer to "Slough Embankment" details and tables.
 ③ Interstate 29 Southbound excavation and embankment will not be measured separately but included in the price bid for "RESHAPING ROADWAY".
 ④ If approved by Engineer, the allocation of excess material designated for placement in each waste sites may be modified.

SLOUGH EMBANKMENT: SHOULDER ALTERNATE A						
Station	Embankment Area		Un-Adjusted Volume (CY)	Adjusted Volume ① (CY)		
	Begin	End			Left (SF)	Right (SF)
1764+76	1813+25	1.8288	2.0151	690	863	
1814+36	1933+60	1.8288	2.0151	1,698	2,123	
1933+60	1945+91	2.0151	2.0151	184	230	
1945+91	1965+05	1.8288	2.0151	272	340	
1965+05	1973+90	2.0151	2.0151	132	165	
1973+90	2138+27	1.8288	2.0151	2,340	2,925	
2138+27	2150+58	2.0151	2.0151	184	230	
2150+58	2163+42	1.8288	2.0151	183	229	
2163+42	2172+27	2.0151	2.0151	132	165	
2172+27	2197+40	1.8288	2.0151	358	448	
2200+24	2201+87	1.8288	2.0151	23	29	
2201+87	2214+17	2.0151	2.0151	184	230	
2214+17	2233+30	1.8288	2.0151	272	340	
2233+30	2242+31	2.0151	2.0151	134	168	
2242+31	2308+70	1.8288	2.0151	945	1,181	
2308+70	2321+01	2.0151	2.0151	184	230	
2321+01	2326+00	1.8288	2.0151	71	89	
TOTAL =				9,985		

Notes:
 ① Additional 25% volume included for shrinkage

SLOUGH EMBANKMENT: SHOULDER ALTERNATE B						
Station	Embankment Area		Un-Adjusted Volume (CY)	Adjusted Volume ① (CY)		
	Begin	End			Left (SF)	Right (SF)
1764+76	1813+25	0.7674	2.0151	500	625	
1814+36	1933+60	0.7674	2.0151	1,229	1,536	
1933+60	1945+91	2.0151	2.0151	184	230	
1945+91	1965+05	0.7674	2.0151	197	246	
1965+05	1973+90	2.0151	2.0151	132	165	
1973+90	2138+27	0.7674	2.0151	1,694	2,118	
2138+27	2150+58	2.0151	2.0151	184	230	
2150+58	2163+42	0.7674	2.0151	132	165	
2163+42	2172+27	2.0151	2.0151	132	165	
2172+27	2197+40	0.7674	2.0151	259	324	
2200+24	2201+87	0.7674	2.0151	17	21	
2201+87	2214+17	2.0151	2.0151	184	230	
2214+17	2233+30	0.7674	2.0151	197	246	
2233+30	2242+31	2.0151	2.0151	134	168	
2242+31	2308+70	0.7674	2.0151	684	855	
2308+70	2321+01	2.0151	2.0151	184	230	
2321+01	2326+00	0.7674	2.0151	51	64	
TOTAL =				7,618		

Notes:
 ① Additional 25% volume included for shrinkage

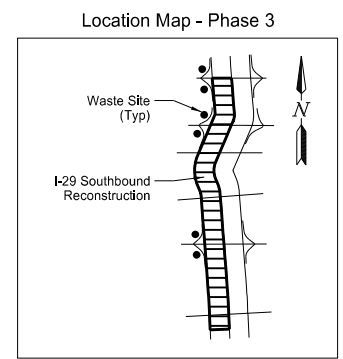
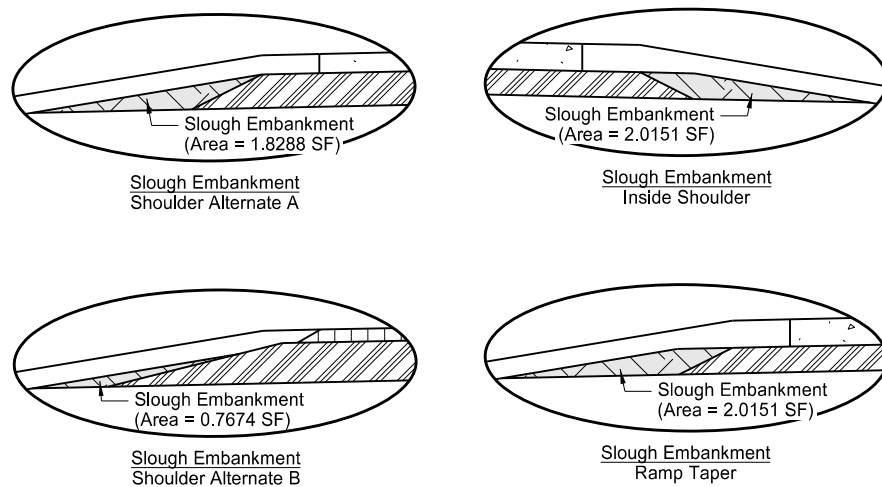

This document was originally issued and sealed by Jonathan D. Bach, Registration Number PE- 9797, on 08/11/17 and the original document is stored at the North Dakota Department of Transportation

I-29 - N of Galchutt Exit to Christine Exit
 Earthwork Summary
 Interstate 29 Southbound
 Phase 3

RAMP CONNECTIONS & GUARDRAIL GRADING - PHASE 4 & 5							
LOCATION	EARTHWORK SUMMARY					TOPSOIL SUMMARY	
	Excavation	Embankment ①	Excess Material	230 0106 RESHAPING ROADWAY (Pay Item) ②	230 0218 GUARDRAIL EMBANKMENT ③	202 0350 REMOVAL OF TEMPORARY BYPASS ④	203 109 TOPSOIL
	(CY)	(CY)	(CY)	(MILE)	(EA)	(EA)	(CY)
	A	B	C = A - B	D	E	F	G
Pitcairn Separation Guardrail Grading (RP 34,040)							
Sta 12+01 to Sta 13+82 Rt (EX68ST)		19	-19		1		19
Sta 16+17 to Sta 17+99 Lt (EX68ST)		10	-10		1		20
Colfax Interchange Ramp Connections (RP 37,043)							
Sta 100+00 to Sta 115+76 (RC_37_N_SER)	133	2,062	-1,929	0.30			423
Sta 201+36 to Sta 220+94 (RC_37_N_NER)	62	3,743	-3,681	0.37			760
Existing Southwest & Northwest Ramp Connection Removal	5,819		5,819			2	
Colfax Separation Guardrail Grading (RP 39,047)							
Sta 12+01 to Sta 13+83 Rt (EX63ST)		26	-26		1		37
Sta 16+18 to Sta 17+99 Lt (EX63ST)		27	-27		1		53
Mile 41 Separation Guardrail Grading (RP 41,053)							
Sta 14+48 to Sta 16+63 Rt (EX61ST)		132	-132		1		115
Sta 19+08 to Sta 21+22 Lt (EX61ST)		10	-10		1		33
Walcott Interchange Ramp Connections (RP 42,169)							
Sta 300+00 to Sta 315+86 (RC_42_N_SER)	17	2,881	-2,864	0.30			515
Sta 401+27 to Sta 421+34 (RC_42_N_NER)	11	6,210	-6,199	0.38			839
Existing Southwest & Northwest Ramp Connection Removal	8,047		8,047			2	
Christine Interchange Ramp Connection (RP 44,126)							
Sta 500+00 to Sta 516+05 (RC_44_N_SER)	82	2,685	-2,603	0.30			519
Existing Southwest Ramp Connection Removal	3,979		3,979			1	
Christine Interchange Guardrail Grading (RP 44,126)							
Sta 15+06 to Sta 16+64 (EX58ST)		168	-168		2		156
Sta 19+39 to Sta 20+98 (EX58ST)		118	-118		2		214
TOTAL (PHASE 4 & 5) =	18,150	18,091	59	1.65	10	5	3,703

Notes:

- ① Additional 25% volume included for shrinkage
- ② Ramp Connection excavation and embankment will not be measured separately but included in the price bid for "RESHAPING ROADWAY".
- ③ Refer to Section 130 for additional details.
- ④ Refer to Section 40 for additional details.

Location Map - Phase 4 & 5

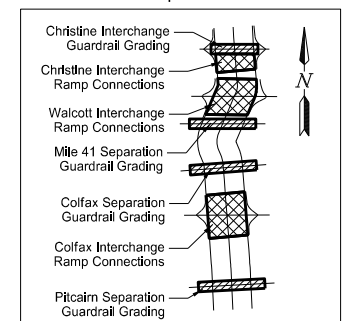

This document was originally issued and sealed by Jonathan D. Bach, Registration Number PE- 9797, on 08/11/17 and the original document is stored at the North Dakota Department of Transportation

I-29 - N of Galchutt Exit to Christine Exit
 Earthwork Summary
 Interstate 29 Southbound
 Phase 4 & 5

I-29 Southbound Reconstruction
(SCL29)

Table 13 of 14

STATION	EXCAVATION		EMBANKMENT		ALTERNATE A SHLDR EMB & WASTE SITES			ALTERNATE B SHLDR EMB & WASTE SITES		
	END AREA (SF)	ADJUSTED VOLUME (CY)	END AREA (SF)	ADJUSTED VOLUME (CY)	EMBANKMENT		MASS (CY)	EMBANKMENT		MASS (CY)
					ADJUSTED VOLUME	TOTAL VOLUME		ADJUSTED VOLUME	TOTAL VOLUME	
2281+00.00	55.71	208.4	0.00	0.0	17.8	17.8	15512.0	12.9	12.9	16157.2
2282+00.00	50.90	197.4	0.15	0.4	17.8	18.2	15691.2	12.9	13.3	16341.3
2283+00.00	52.38	191.3	0.57	1.7	17.8	19.5	15863.0	12.9	14.6	16518.0
2284+00.00	54.06	197.1	1.07	3.8	17.8	21.6	16038.5	12.9	16.7	16698.4
2285+00.00	58.37	208.2	0.00	2.5	17.8	20.3	16226.4	12.9	15.4	16891.2
2286+00.00	67.12	232.4	0.00	0.0	17.8	17.8	16441.0	12.9	12.9	17110.7
2287+00.00	55.25	226.6	1.85	4.3	17.8	22.1	16645.5	12.9	17.2	17320.1
2288+00.00	60.17	213.7	0.06	4.4	17.8	22.2	16837.0	12.9	17.3	17516.5
2289+00.00	52.81	209.2	0.01	0.1	17.8	17.9	17028.3	12.9	13.0	17712.7
2290+00.00	47.51	185.8	0.00	0.0	17.8	17.8	17196.3	12.9	12.9	17885.6
2290+30.00	59.19	59.3	0.67	0.5	5.3	5.8	17249.8	3.9	4.4	17940.5
2291+00.00	40.91	129.7	0.15	1.3	12.5	13.8	17365.7	9.0	10.3	18059.9
2292+00.00	39.20	148.4	0.18	0.8	17.8	18.6	17495.5	12.9	13.7	18194.6
2293+00.00	45.18	156.3	1.58	4.1	17.8	21.9	17629.9	12.9	17.0	18333.9
2294+00.00	53.55	182.8	0.23	4.2	17.8	22.0	17790.7	12.9	17.1	18499.6
2295+00.00	58.92	208.3	0.00	0.5	17.8	18.3	17980.7	12.9	13.4	18694.5
2296+00.00	45.44	193.2	2.58	6.0	17.8	23.8	18150.1	12.9	18.9	18868.8
2297+00.00	38.87	156.1	1.83	10.2	17.8	28.0	18278.2	12.9	23.1	19001.8
2298+00.00	38.33	143.0	0.33	5.0	17.8	22.8	18398.4	12.9	17.9	19126.9
2299+00.00	50.76	165.0	0.00	0.8	17.8	18.6	18544.8	12.9	13.7	19278.2
2299+20.00	43.11	34.8	0.00	0.0	3.6	3.6	18576.0	2.6	2.6	19310.4
2299+40.00	41.38	31.3	6.61	3.1	3.6	6.7	18600.6	2.6	5.7	19336.0
2300+00.00	48.53	99.9	0.10	9.3	10.7	20.0	18680.5	7.7	17.0	19418.9
2301+00.00	51.43	185.1	1.29	3.2	17.8	21.0	18844.6	12.9	16.1	19587.9
2302+00.00	50.29	188.4	2.29	8.3	17.8	26.1	19006.9	12.9	21.2	19755.1
2303+00.00	49.86	185.5	0.00	5.3	17.8	23.1	19169.3	12.9	18.2	19922.4
2304+00.00	49.92	184.8	0.06	0.1	17.8	17.9	19336.2	12.9	13.0	20094.2
2305+00.00	50.61	186.2	0.47	1.2	17.8	19.0	19503.4	12.9	14.1	20266.3
2306+00.00	42.62	172.7	0.00	1.1	17.8	18.9	19657.2	12.9	14.0	20425.0
2307+00.00	47.29	166.5	0.00	0.0	17.8	17.8	19805.9	12.9	12.9	20578.6
2308+00.00	45.07	171.0	0.72	1.7	17.8	19.5	19957.4	12.9	14.6	20735.0
2308+71.00	48.14	122.6	1.85	4.2	12.6	16.8	20063.2	9.1	13.3	20844.3
2309+00.00	51.12	53.3	2.13	2.7	5.4	8.1	20108.4	5.4	8.1	20889.5
2309+50.00	55.84	99.0	0.22	2.7	9.3	12.0	20195.4	9.3	12.0	20976.5
2310+00.00	56.12	103.7	0.27	0.6	9.3	9.9	20289.2	9.3	9.9	21070.3
2310+50.00	57.25	105.0	0.00	0.3	9.3	9.6	20384.6	9.3	9.6	21165.7
2310+70.40	61.51	44.9	0.00	0.0	3.8	3.8	20425.7	3.8	3.8	21206.8
2311+00.00	62.83	68.2	0.00	0.0	5.5	5.5	20488.4	5.5	5.5	21269.5
2311+50.00	58.03	111.9	0.00	0.0	9.3	9.3	20591.0	9.3	9.3	21372.1
2312+00.00	63.56	112.6	0.00	0.0	9.3	9.3	20694.3	9.3	9.3	21475.4
2312+32.00	66.13	76.9	0.12	0.1	6.0	6.1	20765.1	6.0	6.1	21546.2
2312+50.00	73.48	46.5	0.00	0.1	3.4	3.5	20808.1	3.4	3.5	21589.2
2313+00.00	52.79	116.9	0.57	0.7	9.3	10.0	20915.0	9.3	10.0	21696.1
2313+50.00	60.12	104.5	0.48	1.2	9.3	10.5	21009.0	9.3	10.5	21790.1
2314+00.00	62.85	113.9	0.50	1.1	9.3	10.4	21112.5	9.3	10.4	21893.6
2314+50.00	62.58	116.1	0.15	0.8	9.3	10.1	21218.5	9.3	10.1	21999.6
2315+00.00	58.87	112.4	0.71	1.0	9.3	10.3	21320.6	9.3	10.3	22101.7
2315+50.00	52.70	103.3	2.40	3.6	9.3	12.9	21411.0	9.3	12.9	22192.1
2316+00.00	43.99	89.5	3.23	6.5	9.3	15.8	21484.7	9.3	15.8	22265.8
2316+50.00	41.88	79.5	2.38	6.5	9.3	15.8	21548.4	9.3	15.8	22329.5
2317+00.00	41.11	76.8	2.23	5.3	9.3	14.6	21610.6	9.3	14.6	22391.7
2317+50.00	55.34	89.3	0.51	3.2	9.3	12.5	21687.4	9.3	12.5	22468.5
2318+00.00	51.16	98.6	1.97	2.9	9.3	12.2	21773.8	9.3	12.2	22554.9
2318+50.00	50.10	93.8	4.82	7.9	9.3	17.2	21850.4	9.3	17.2	22631.5
2318+60.00	49.90	18.5	4.96	2.3	1.9	4.2	21864.7	1.9	4.2	22645.8
2318+70.34	48.84	18.9	4.55	2.3	1.9	4.2	21879.4	1.9	4.2	22660.5
2319+00.00	48.86	53.7	3.12	5.3	5.5	10.8	21922.3	5.5	10.8	22703.4
2319+21.00	45.76	36.8	5.86	4.4	3.9	8.3	21950.8	3.9	8.3	22731.9
2319+50.00	48.73	50.7	6.37	8.2	5.4	13.6	21987.9	5.4	13.6	22769.0
2320+00.00	37.59	79.9	9.79	18.7	9.3	28.0	22039.8	9.3	28.0	22820.9
2320+50.00	36.61	68.7	9.09	21.9	9.3	31.2	22077.3	9.3	31.2	22858.4
2320+94.00	62.15	80.5	1.05	10.3	8.2	18.5	22139.3	8.2	18.5	22920.4
2321+00.00	50.45	12.5	0.00	0.1	1.1	1.2	22150.6	1.1	1.2	22931.7
2321+01.00	45.55	1.8	0.00	0.0	0.2	0.2	22152.2	0.2	0.2	22933.3
2322+00.00	42.83	162.0	0.19	0.4	17.7	18.1	22296.1	12.7	13.1	23082.2
2323+00.00	29.85	134.6	0.16	0.8	17.8	18.6	22412.1	12.8	13.6	23203.2
2324+00.00	27.24	105.7	0.20	0.8	17.8	18.6	22499.2	12.8	13.6	23295.3
2324+31.00	40.21	38.7	5.49	4.1	5.5	9.6	22528.3	4.0	8.1	23325.9

I-29 Southbound Reconstruction
(SCL29)

Table 14 of 14

STATION	EXCAVATION		EMBANKMENT		ALTERNATE A SHLDR EMB & WASTE SITES			ALTERNATE B SHLDR EMB & WASTE SITES		
	END AREA (SF)	ADJUSTED VOLUME (CY)	END AREA (SF)	ADJUSTED VOLUME (CY)	EMBANKMENT		MASS (CY)	EMBANKMENT		MASS (CY)
					ADJUSTED VOLUME	TOTAL VOLUME		ADJUSTED VOLUME	TOTAL VOLUME	
2325+00.00	36.13	97.5	0.82	10.1	12.3	22.4	22603.4	8.8	18.9	23404.5
2325+80.00	32.17	101.2	1.63	4.5	14.3	18.8	22685.8	10.3	14.8	23490.9
2325+99.99	32.87	24.1	1.35	1.4	10020.6	10022.0	12687.9	10374.6	10376.0	13139.0
2332+00.00	0.00	0.0	0.00	0.0	12687.9	12687.9	0.0	13139.0	13139.0	0.0

Colfax Interchange Southeast Ramp Connection
(RC_37_N_SER)

Table 1 of 1

STATION	END AREA (SF)		ADJUSTED VOLUME (CY)		
	EXC	FILL	EXC	FILL	MASS
100+00.00	3.04	0.56	0.0	0.0	0.0
100+50.00	3.96	0.08	6.5	0.7	5.8
100+80.07	2.77	0.10	3.7	0.1	9.4
101+00.00	2.94	0.14	2.1	0.1	11.4
101+50.00	3.56	0.49	6.0	0.7	16.7
102+00.00	4.44	1.19	7.4	1.9	22.2
102+50.00	4.95	2.89	8.7	4.7	26.2
103+00.00	4.98	5.01	9.2	9.1	26.3
103+50.00	4.68	7.53	8.9	14.5	20.7
104+00.00	4.07	9.87	8.1	20.1	8.7
104+50.00	3.29	14.11	6.8	27.8	-12.3
105+00.00	2.82	18.93	5.7	38.2	-44.8
105+50.00	3.14	18.99	5.5	43.9	-83.2
106+00.00	3.36	20.45	6.0	45.7	-122.9
106+50.00	2.67	26.06	5.6	53.8	-171.1
107+00.00	2.05	30.72	4.4	65.7	-232.4
107+20.27	2.01	31.22	1.5	29.1	-260.0
107+50.00	2.16	31.51	2.3	43.2	-300.9
108+00.00	2.40	35.01	4.2	77.0	-373.7
108+39.00	2.57	37.90	3.6	65.8	-435.9
108+50.00	2.00	38.68	0.9	19.5	-454.5
109+00.00	0.00	53.47	1.9	106.7	-559.3
109+50.00	0.00	62.70	0.0	134.5	-693.8
110+00.00	0.00	55.90	0.0	137.3	-831.1
110+50.00	0.63	33.72	0.6	103.7	-934.2
110+64.00	2.10	26.97	0.7	19.7	-953.2
111+00.00	3.06	12.96	3.4	33.3	-983.1
111+49.00	2.95	0.00	5.5	14.7	-992.3
112+04.00	1.03	0.00	0.0	0.0	-992.3
112+50.00	1.16	6.53	1.9	7.0	-997.4
112+66.00	1.08	12.30	0.7	7.0	-1003.7
113+00.00	0.00	47.31	0.7	46.9	-1049.9
113+50.00	0.00	103.56	0.0	174.6	-1224.5
113+73.00	1.26	129.20	0.5	123.9	-1347.9
114+00.00	1.16	124.46	1.2	158.5	-1505.2
114+50.00	1.33	73.51	2.3	229.1	-1732.0
115+00.00	1.44	41.89	2.6	133.6	-1863.0
115+50.00	1.64	11.38	2.8	61.7	-1921.9
115+76.00	1.56	2.74	1.5	8.5	-1928.9
#VALUE!	0.00	0.00	0.0	0.0	-1928.9

Location Map - Phase 3

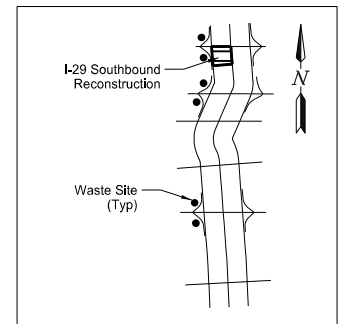

Location Map - Phase 4 & 5

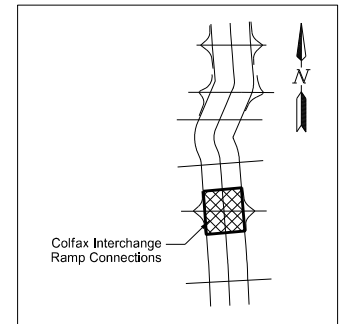

This document was originally issued and sealed by Jonathan D. Bach, Registration Number PE- 9797, on 08/07/17 and the original document is stored at the North Dakota Department of Transportation

</

Colfax Interchange Northeast Ramp Connection
(RC_37_N_NER)

Table 1 of 1

STATION	END AREA (SF)		ADJUSTED VOLUME (CY)		
	EXC	FILL	EXC	FILL	MASS
201+37.00	1.41	1.25	0.0	0.0	0.0
201+50.00	1.44	3.39	0.7	1.4	-0.7
201+89.38	0.94	18.49	1.7	19.9	-18.9
202+00.00	0.88	27.65	0.4	11.3	-29.8
202+50.00	1.81	84.91	2.5	130.3	-157.6
203+00.00	1.98	124.42	3.5	242.3	-396.4
203+50.00	0.02	127.98	1.9	292.1	-686.6
204+00.00	0.00	80.37	0.0	241.1	-927.7
204+49.00	0.58	22.22	0.5	116.4	-1043.6
204+50.00	1.31	21.31	0.0	1.0	-1044.6
205+00.00	2.06	0.02	3.1	24.7	-1066.2
205+15.00	1.45	0.00	1.0	0.0	-1065.2
205+71.00	2.72	0.00	0.0	0.0	-1065.2
206+00.00	3.01	6.38	3.1	4.3	-1066.4
206+50.00	2.52	35.54	5.1	48.5	-1109.8
206+58.00	2.24	41.59	0.7	14.3	-1123.4
207+00.00	0.00	71.51	1.7	110.0	-1231.7
207+50.00	0.00	85.06	0.0	181.2	-1412.9
208+00.00	0.00	78.59	0.0	189.4	-1602.3
208+50.00	0.01	65.30	0.0	166.5	-1768.8
209+00.00	1.52	53.75	1.4	137.8	-1905.2
209+13.00	1.99	51.47	0.8	31.7	-1936.1
209+50.00	2.14	48.12	2.8	85.3	-2018.6
209+93.47	2.23	43.19	3.5	91.9	-2107.0
210+00.00	2.21	42.82	0.5	13.0	-2119.5
210+50.00	1.23	47.77	3.2	104.9	-2221.2
211+00.00	0.89	45.84	2.0	108.4	-2327.6
211+50.00	1.00	41.68	1.7	101.3	-2427.2
212+00.00	0.95	36.43	1.8	90.4	-2515.8
212+50.00	0.67	40.59	1.5	89.1	-2603.4
213+00.00	1.17	41.73	1.7	95.3	-2697.0
213+50.00	0.93	43.87	1.9	99.1	-2794.2
214+00.00	0.74	43.69	1.5	101.3	-2894.0
214+50.00	0.16	41.40	0.8	98.5	-2991.7
215+00.00	0.32	40.23	0.4	94.5	-3085.8
215+50.00	0.21	40.59	0.5	93.5	-3178.8
216+00.00	0.56	35.52	0.7	88.1	-3266.2
216+50.00	0.66	31.96	1.1	78.1	-3343.2
217+00.00	0.51	29.94	1.1	71.7	-3413.8
217+50.00	0.31	31.48	0.8	71.1	-3484.1
217+70.00	0.30	34.35	0.2	30.5	-3514.4
218+00.00	0.45	28.17	0.4	43.4	-3557.4
218+50.00	0.41	18.77	0.8	54.3	-3610.9
219+00.00	0.14	12.16	0.5	35.8	-3646.2
219+50.00	0.47	6.28	0.6	21.3	-3666.9
219+93.67	0.52	2.41	0.8	8.8	-3674.9
220+00.00	0.72	2.60	0.1	0.7	-3675.5
220+50.00	0.73	1.89	1.3	5.2	-3679.4
220+91.00	0.81	1.14	1.2	2.9	-3681.1

Walcott Interchange Southeast Ramp Connection
(RC_42_N_SER)

Table 1 of 1

STATION	END AREA (SF)		ADJUSTED VOLUME (CY)		
	EXC	FILL	EXC	FILL	MASS
300+01.00	0.00	0.88	0.0	0.0	0.0
300+50.00	0.08	0.49	0.1	1.6	-1.5
300+80.07	0.07	0.54	0.1	0.7	-2.1
301+00.00	0.01	0.71	0.0	0.6	-2.7
301+50.00	0.00	1.28	0.0	2.3	-5.0
302+00.00	0.91	1.06	0.8	2.7	-6.9
302+50.00	0.38	4.48	1.2	6.4	-12.1
303+00.00	0.46	7.51	0.8	13.9	-25.2
303+50.00	0.03	14.84	0.5	25.9	-50.6
304+00.00	0.00	19.81	0.0	40.1	-90.7
304+50.00	0.00	24.89	0.0	51.7	-142.4
305+00.00	0.00	27.50	0.0	60.6	-203.0
305+44.00	0.00	51.74	0.0	80.7	-283.7
305+50.00	0.00	49.70	0.0	14.1	-297.8
306+00.00	0.00	42.50	0.0	106.7	-404.5
306+50.00	0.00	44.83	0.0	101.1	-505.6
307+00.00	0.00	40.50	0.0	98.8	-604.4
307+20.27	0.00	37.50	0.0	36.6	-641.0
307+50.00	0.00	36.65	0.0	51.0	-692.0
308+00.00	0.00	39.74	0.0	88.4	-780.4
308+39.00	0.00	42.06	0.0	73.9	-854.3
308+50.00	0.00	44.41	0.0	22.0	-876.3
309+00.00	0.00	61.73	0.0	122.8	-999.1
309+50.00	0.00	71.01	0.0	153.6	-1152.7
310+00.00	0.00	73.12	0.0	166.8	-1319.5
310+50.00	0.07	50.55	0.1	143.1	-1462.5
310+65.00	0.37	45.25	0.1	33.3	-1495.7
311+00.00	0.73	18.49	0.7	51.6	-1546.6
311+49.00	0.51	1.20	1.1	22.3	-1567.8
312+04.00	1.09	0.00	0.0	0.0	-1567.8
312+50.00	0.93	6.18	1.7	6.6	-1572.7
312+67.00	0.47	14.88	0.4	8.3	-1580.6
313+00.00	0.00	58.60	0.3	56.1	-1636.4
313+50.00	0.00	130.80	0.0	219.2	-1855.6
314+00.00	1.25	153.46	1.2	329.0	-2183.4
314+50.00	1.47	117.79	2.5	313.9	-2494.8
314+62.00	1.32	119.68	0.6	66.0	-2560.2
315+00.00	1.27	67.12	1.8	164.3	-2722.7
315+45.27	0.98	33.20	1.9	105.1	-2825.9
315+50.00	0.96	29.85	0.2	6.9	-2832.6
315+86.00	0.87	8.30	1.2	31.8	-2863.2

Walcott Interchange Northeast Ramp Connection
(RC_42_N_NER)

Table 1 of 1

STATION	END AREA (SF)		ADJUSTED VOLUME (CY)		
	EXC	FILL	EXC	FILL	MASS
401+27.00	1.34	1.07	0.0	0.0	0.0
401+50.00	1.03	4.81	1.0	3.1	-2.1
401+85.90	1.43	18.58	1.6	19.4	-19.9
402+00.00	1.29	30.51	0.7	16.0	-35.2
402+50.00	1.22	89.64	2.3	139.1	-172.0
403+00.00	1.03	165.11	2.1	294.8	-464.7
403+36.00	0.80	223.83	1.2	324.1	-787.6
403+46.00	0.00	237.69	0.1	106.8	-894.3
403+50.00	0.00	230.67	0.0	43.4	-937.7
404+00.00	0.00	160.87	0.0	453.2	-1390.9
404+50.00	0.00	114.53	0.0	318.7	-1709.6
405+00.00	0.00	59.07	0.0	200.9	-1910.5
405+22.00	0.00	27.61	0.0	44.1	-1954.6
405+50.00	0.00	10.26	0.0	24.5	-1979.1
405+82.00	0.26	0.00	0.2	7.6	-1986.5
406+35.00	0.62	0.50	0.0	0.0	-1986.5
406+50.00	0.56	5.46	0.3	2.1	-1988.3
407+00.00	0.38	43.84	0.9	57.1	-2044.5
407+16.00	0.33	55.07	0.2	36.6	-2080.9
407+50.00	0.00	84.62	0.2	109.9	-2190.6
408+00.00	0.00	108.50	0.0	223.5	-2414.1
408+50.00	0.00	112.36	0.0	255.6	-2669.7
409+00.00	0.00	113.22	0.0	261.1	-2930.8
409+45.00	0.00	117.96	0.0	240.8	-3171.6
409+50.00	0.00	116.32	0.0	27.1	-3198.7
410+00.00	0.00	103.95	0.0	254.9	-3453.6
410+39.62	0.00	98.67	0.0	185.8	-3639.4
410+50.00	0.00	96.73	0.0	47.0	-3686.4
411+00.00	0.00	88.86	0.0	214.8	-3901.2
411+50.00	0.00	90.08	0.0	207.1	-4108.3
412+00.00	0.00	90.10	0.0	208.5	-4316.8
412+50.00	0.00	85.30	0.0	203.0	-4519.8
413+00.00	0.00	81.41	0.0	193.0	-4712.8
413+50.00	0.00	78.90	0.0	185.5	-4898.3
414+00.00	0.00	75.72	0.0	179.0	-5077.3
414+50.00	0.00	70.47	0.0	169.2	-5246.5
415+00.00	0.00	67.60	0.0	159.8	-5406.3
415+50.00	0.00	62.43	0.0	150.5	-5556.8
416+00.00	0.00	56.00	0.0	137.1	-5693.9
416+50.00	0.00	46.70	0.0	118.9	-5812.8
417+00.00	0.00	30.15	0.0	88.9	-5901.7
417+50.00	0.00	20.83	0.0	59.0	-5960.7
418+00.00	0.00	15.95	0.0	42.6	-6003.3
418+50.00	0.00	14.53	0.0	35.3	-6038.6
419+00.00	0.00	12.36	0.0	31.1	-6069.7
419+50.00	0.00	12.43	0.0	28.7	-6098.4
420+00.00	0.00	11.43	0.0	27.6	-6126.0
420+30.70	0.00	11.38	0.0	16.2	-6142.2
420+50.00	0.00	11.63	0.0	10.3	-6152.5
421+00.00	0.00	12.04	0.0	27.4	-6179.9
421+34.40	0.00	11.57	0.0	18.8	-6198.7

Christine Interchange Southeast Ramp Connection
(RC_44_N_SER)

Table 1 of 1

STATION	END AREA (SF)		ADJUSTED VOLUME (CY)		
	EXC	FILL	EXC	FILL	MASS
500+01.00	3.24	0.00	0.0	0.0	0.0
500+50.00	3.27	0.05	5.9	0.1	5.8
500+85.07	3.53	0.00	4.4	0.0	10.2
501+00.00	3.53	0.03	2.0	0.0	12.2
501+50.00	2.84	1.82	5.9	2.1	16.0
502+00.00	2.66	2.87	5.1	5.4	15.7
502+46.00	2.43	11.73	4.3	15.5	4.5
502+50.00	2.41	9.84	0.4	2.0	2.9
503+00.00	2.78	4.15	4.8	16.2	-8.5
503+50.00	3.04	15.03	5.4	22.2	-25.3
504+00.00	3.15	18.66	5.7	39.0	-58.6
504+50.00	2.95	20.46	5.6	45.3	-98.3
505+00.00	3.04	24.99	5.5	52.6	-145.4
505+50.00	2.29	32.37	4.9	66.4	-206.9
506+00.00	1.02	40.95	3.1	84.9	-288.7
506+50.00	0.67	46.00	1.6	100.6	-387.7
507+00.00	0.42	49.10	1.0	110.1	-496.8
507+20.27	0.26	51.53	0.3	47.2	-543.7
507+50.00	0.96	45.08	0.7	66.5	-609.5
508+00.00	0.61	49.84	1.4	109.9	-718.0
508+39.00	0.25	59.51	0.6	98.7	-816.1
508+50.00	0.22	57.86	0.1	29.9	-845.9
509+00.00	0.00	82.75	0.2	162.7	-1008.4
509+50.00	0.00	103.84	0.0	216.0	-1224.4
510+00.00	0.00	110.43	0.0	248.0	-1472.4
510+50.00	0.00	92.61	0.0	235.0	-1707.4
510+64.00	0.35	81.60	0.1	56.5	-1763.8
511+00.00	0.43	46.91	0.5	107.1	-1870.4
511+49.00	0.38	1.42	0.7	54.8	-1924.5
512+04.00	1.33	0.00	0.0	0.0	-1924.5
512+50.00	0.75	6.70	1.8	7.1	-1929.8
512+67.00	0.99	13.			

**Interstate 29 - Southbound
Alternate A: Concrete Shoulders
(Phase 3)**

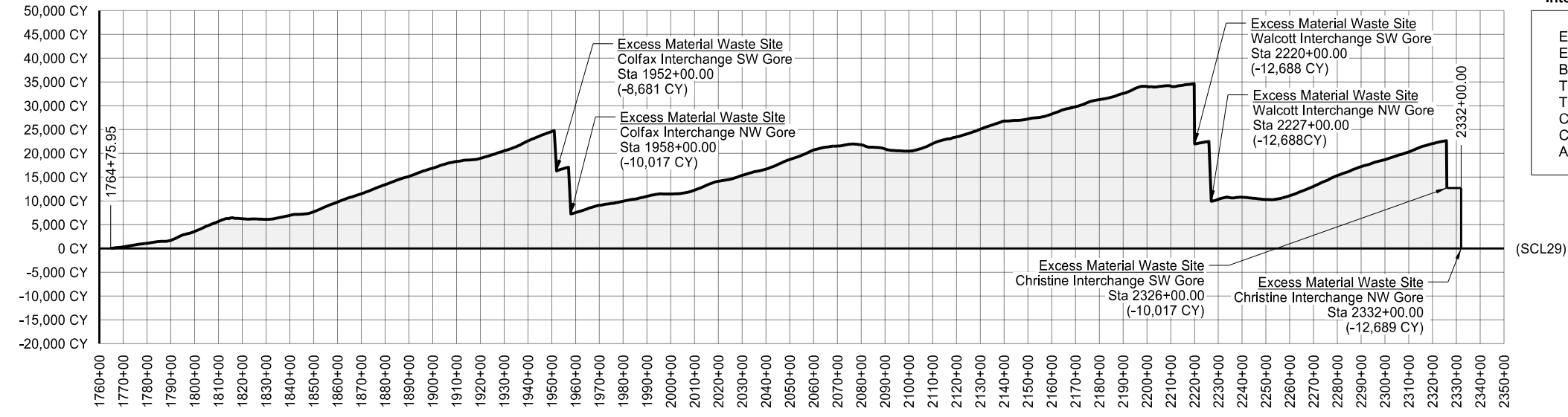

Interstate 29 Southbound - Alternate A

EMBANKMENT =	85,556.00
EXCAVATION =	85,556.00
BORROW =	0.00
TOPSOIL FILL =	71,470.00
TOPSOIL CUT =	71,470.00
CUBIC YARD STA =	7,567,222.55
CUBIC YARDS =	69,333.56
AVERAGE HAUL =	109.14 STA

Location Map - Phase 3

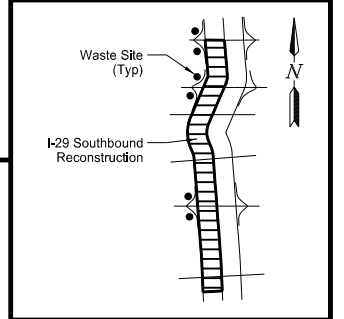

**Interstate 29 - Southbound
Alternate B: Concrete Median Shoulder w/ 8' Asphalt Outside Shoulder
(Phase 3)**

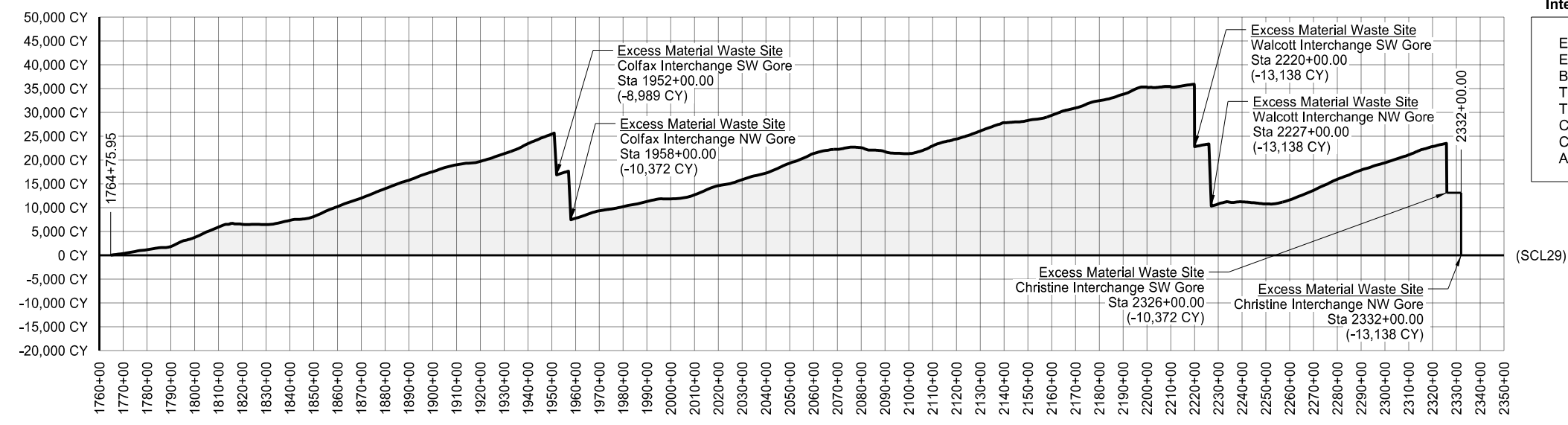

Interstate 29 Southbound - Alternate B

EMBANKMENT =	85,556.00
EXCAVATION =	85,556.00
BORROW =	0.00
TOPSOIL FILL =	71,470.00
TOPSOIL CUT =	71,470.00
CUBIC YARD STA =	7,859,433.37
CUBIC YARDS =	71,445.69
AVERAGE HAUL =	110.01 STA

This document was originally issued and sealed by Jonathan D. Bach, Registration Number PE- 9797, on 08/11/17 and the original document is stored at the North Dakota Department of Transportation

I-29 - N of Galchutt Exit to Christine Exit
Mass Haul Diagrams
Interstate 29 Southbound
Phase 3 - Shoulder Alternate A & B

Interstate 29
Chain = SCL29
Curve = SCL29-3

P.C. Station	=	2068+45.47
P.I. Station	=	2079+79.10
P.T. Station	=	2091+05.38
Delta	=	11° 17' 58" (LT)
Degree	=	0° 30' 00"
Tangent	=	1,133.63
Length	=	2,259.91
Radius	=	11,459.20
External	=	55.94
Back	=	N 03° 38' 18.80" W
Ahead	=	N 14° 56' 17.07" W
Chord Bearing	=	N 09° 17' 17.94" W
Existing Full Super	=	2.2%
Proposed Full Super	=	2.2%

Station		Left Slope	Right Slope
2067+10.31	PC - 135.16	-2.1	-2.1
2067+89.89	PC - 55.58	-2.1	0.0
	PC		
2068+69.47	PC + 24.00	-2.1	2.1
2068+73.26	PC + 27.79	-2.2	2.2
2090+77.59	PT - 27.79	-2.2	2.2
2090+81.38	PT - 24.00	-2.1	2.1
	PT		
2091+60.96	PT + 55.58	-2.1	0.0
2092+40.54	PT + 135.16	-2.1	-2.1

Interstate 29
Chain = SCL29
Curve = SCL29-4

P.C. Station	=	2101+15.81
P.I. Station	=	2121+01.99
P.T. Station	=	2140+12.85
Delta	=	27° 16' 44" (RT)
Degree	=	0° 42' 00"
Tangent	=	1,986.18
Length	=	3,897.05
Radius	=	8,185.24
External	=	237.53
Back	=	N 14° 56' 17.07" W
Ahead	=	N 12° 20' 26.95" E
Chord Bearing	=	N 01° 17' 55.06" W
Existing Full Super	=	2.8%
Proposed Full Super	=	2.8%

Station		Left Slope	Right Slope
2099+65.49	PC - 150.32	-2.1	-2.1
2100+45.07	PC - 70.74	0.0	-2.1
	PC		
2101+24.65	PC + 8.84	2.1	-2.1
2101+51.18	PC + 35.37	2.8	-2.8
2139+77.48	PT - 35.37	2.8	-2.8
2140+04.01	PT - 8.84	2.1	-2.1
	PT		
2140+83.59	PT + 70.74	0.0	-2.1
2141+63.17	PT + 150.32	-2.1	-2.1

Interstate 29
Chain = SCL29
Spiral/Curve/Spiral = SCL29-5B/SCL29-5/SCL29-5A

Simple Curve		
T.S. Station	=	2233+89.00
S.C. Station	=	2235+89.00
P.I. Station	=	2243+04.90
C.S. Station	=	2250+13.41
S.T. Station	=	2252+13.41
Delta	=	14° 14' 38" (LT)
Degree	=	1° 00' 00"
Tangent	=	715.90
Length	=	1,424.42
Radius	=	5,729.65
External	=	44.55
Back	=	N 11° 20' 27.00" E
Ahead	=	N 02° 54' 11.36" W
Chord Bearing	=	N 04° 13' 07.82" E
Existing Full Super	=	3.8%
Proposed Full Super	=	3.8%
Total Combination		
P.I. Station	=	2243+06.73
Delta	=	16° 14' 38" (LT)
Spiral Length	=	200.00
External	=	58.35
Back	=	N 12° 20' 26.95" E
Ahead	=	N 03° 54' 11.31" W
Chord Bearing	=	N 04° 13' 07.82" E

	Station		Left Slope	Right Slope
	2232+78.47	SC - 310.53	-2.1	-2.1
TS	2233+89.00	SC - 200.00	-2.1	0.0
	2233+99.53	SC - 189.47	-2.1	2.1
	2235+89.00	SC	-3.8	3.8
	2250+13.41	CS	-3.8	3.8
	2252+02.88	CS + 189.47	-2.1	2.1
ST	2252+13.41	CS + 200.00	-2.1	0.0
	2253+23.94	CS + 310.53	-2.1	-2.1

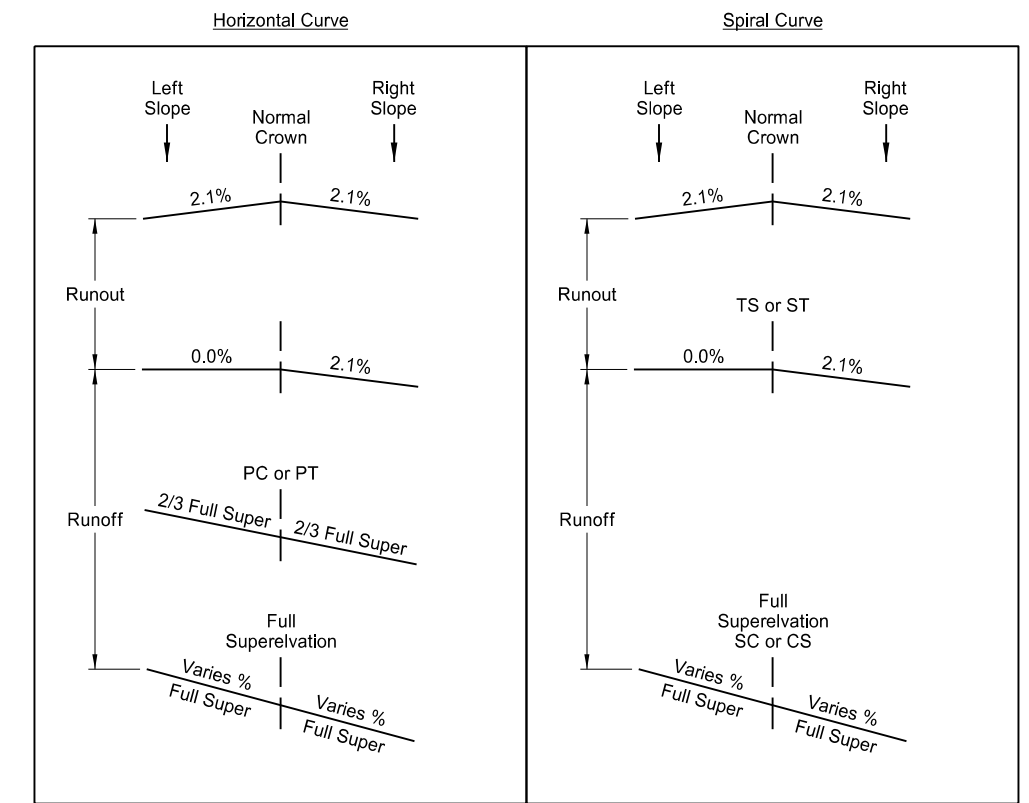

This document was originally issued and sealed by Jonathan D. Bach, Registration Number PE- 9797, on 08/07/17 and the original document is stored at the North Dakota Department of Transportation

I-29 - N of Galchutt Exit to Christine Exit
Superelevation Detail
I-29 Southbound

Notes:
1. Calculations based on AASHTO method five. A design speed of 75 mph and maximum superelevation of 6% used.

Colfax Interchange - SW Ramp
Chain = EXCOLSWR
Curve = EXCOLSWR-1

P.C. Station	=	10+00.20
P.I. Station	=	14+13.15
P.T. Station	=	18+04.29
Delta	=	32° 09' 50" (LT)
Degree	=	4° 00' 00"
Tangent	=	412.95
Length	=	804.09
Radius	=	1,432.39
External	=	58.34
Back	=	N 4° 46' 55.71" W
Ahead	=	N 36° 56' 45.71" W
Chord Bearing	=	N 20° 51' 50.71" W

Station (Ramp)	Station (SCL29)	Ramp Cross Slope
9+29.27	1942+89.51	-2.1
12+28.58	1945+90.64	-5.3

Station (Ramp)	Station (SCL29)	Gore Area Cross Slope
10+49.47	1944+10.64	-2.1
12+28.58	1945+90.64	-2.7

Colfax Interchange - NW Ramp
Chain = EXCOLNWR
Curve = EXCOLNWR-1

P.C. Station	=	5+16.08
P.I. Station	=	9+31.91
P.T. Station	=	13+25.50
Delta	=	32° 22' 37" (LT)
Degree	=	4° 00' 00"
Tangent	=	415.84
Length	=	809.42
Radius	=	1,432.39
External	=	59.14
Back	=	N 30° 10' 21.58" E
Ahead	=	N 2° 12' 15.42" W
Chord Bearing	=	N 13° 59' 03.08" E

Station (Ramp)	Station (SCL29)	Ramp Cross Slope
10+82.19	1965+05.00	-5.2
13+96.43	1968+20.94	-2.1

Station (Ramp)	Station (SCL29)	Gore Area Cross Slope
10+82.19	1965+05.00	-2.1
12+17.04	1966+40.00	-2.1

Rest Area - SW Ramp
Chain = EXTRASWR
Curve = EXTRASWR-2

P.C. Station	=	10+01.90
P.I. Station	=	11+90.48
P.T. Station	=	13+76.90
Delta	=	15° 00' 00" (LT)
Degree	=	4° 00' 00"
Tangent	=	188.58
Length	=	375.00
Radius	=	1,432.39
External	=	12.36
Back	=	N 11° 11' 43.04" E
Ahead	=	N 3° 48' 16.96" W
Chord Bearing	=	N 3° 41' 43.04" E

Station (Ramp)	Station (SCL29)	Ramp Cross Slope
9+30.97	2147+56.52	-2.1
12+30.28	2150+57.65	-5.7

Station (Ramp)	Station (SCL29)	Gore Area Cross Slope
10+51.17	2148+77.65	-2.1
12+30.28	2150+57.65	-2.9

Rest Area - NW Ramp
Chain = EXRANWR
Curve = EXRANWR-1

P.C. Station	=	2+55.70
P.I. Station	=	5+47.12
P.T. Station	=	8+30.70
Delta	=	23° 00' 00" (LT)
Degree	=	4° 00' 00"
Tangent	=	291.42
Length	=	575.00
Radius	=	1,432.39
External	=	29.34
Back	=	N 36° 46' 22.50" E
Ahead	=	N 13° 46' 22.50" E
Chord Bearing	=	N 25° 16' 22.50" E

Station (Ramp)	Station (SCL29)	Ramp Cross Slope
5+87.39	2163+42.30	-5.8
9+01.63	2166+58.24	-2.1

Station (Ramp)	Station (SCL29)	Gore Area Cross Slope
5+87.39	2163+42.30	-0.7
7+37.12	2164+92.30	-2.1

Walcott Interchange - SW Ramp
Chain = EX60SWR
Curve = EX60SWR-1

P.C. Station	=	10+00.20
P.I. Station	=	14+76.08
P.T. Station	=	19+19.09
Delta	=	36° 45' 20" (LT)
Degree	=	4° 00' 00"
Tangent	=	475.88
Length	=	918.89
Radius	=	1,432.39
External	=	76.98
Back	=	N 11° 11' 42.21" E
Ahead	=	N 25° 33' 37.79" W
Chord Bearing	=	N 7° 10' 57.79" W

Station (Ramp)	Station (SCL29)	Ramp Cross Slope
9+29.27	2211+15.60	-2.1
12+28.58	2214+16.73	-4.8

Station (Ramp)	Station (SCL29)	Gore Area Cross Slope
10+49.47	2212+36.73	-2.1
12+28.58	2214+16.73	-0.9

Walcott Interchange - NW Ramp
Chain = EX60NWR
Curve = EX60NWR-2

P.C. Station	=	5+64.19
P.I. Station	=	10+01.44
P.T. Station	=	14+12.94
Delta	=	33° 57' 01" (LT)
Degree	=	4° 00' 00"
Tangent	=	437.24
Length	=	848.75
Radius	=	1,432.39
External	=	65.25
Back	=	N 46° 44' 26.84" E
Ahead	=	N 12° 47' 26.29" E
Chord Bearing	=	N 29° 45' 56.57" E

Station (Ramp)	Station (SCL29)	Ramp Cross Slope
11+54.69	2233+29.86	-5.3
14+83.87	2236+17.61	-3.8

Station (Ramp)	Station (SCL29)	Gore Area Cross Slope
11+54.69	2233+29.86	-0.6
13+04.04	2234+79.86	-2.8

Christine Interchange - SW Ramp
Chain = EX58SWR
Curve = EX58SWR-1

P.C. Station	=	10+00.20
P.I. Station	=	14+12.85
P.T. Station	=	18+03.75
Delta	=	32° 08' 31" (LT)
Degree	=	4° 00' 00"
Tangent	=	412.65
Length	=	803.55
Radius	=	1,432.39
External	=	58.26
Back	=	N 5° 02' 56.06" W
Ahead	=	N 37° 11' 27.06" W
Chord Bearing	=	N 21° 07' 11.56" W

Station (Ramp)	Station (SCL29)	Ramp Cross Slope
9+29.27	2317+99.54	-2.1
12+28.58	2321+00.67	-5.0

Station (Ramp)	Station (SCL29)	Gore Area Cross Slope
10+49.47	2319+20.67	-2.1
12+28.58	2321+00.67	-1.4

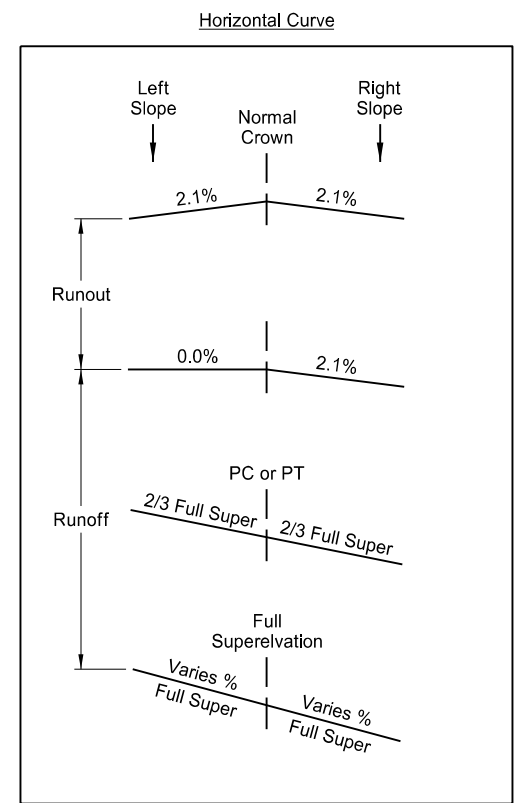

This document was originally issued and sealed by Jonathan D. Bach, Registration Number PE- 9797, on 08/17/17 and the original document is stored at the North Dakota Department of Transportation

I-29 - N of Galchutt Exit to Christine Exit
Superelevation Detail
I-29 Southbound Ramp Tapers

Notes:
1. Calculations based on AASHTO method five. A design speed of 60 mph and maximum superelevation of 6% used.

STATE	PROJECT NO.	SECTION NO.	SHEET NO.
ND	IM-8-029(170)033	20	3

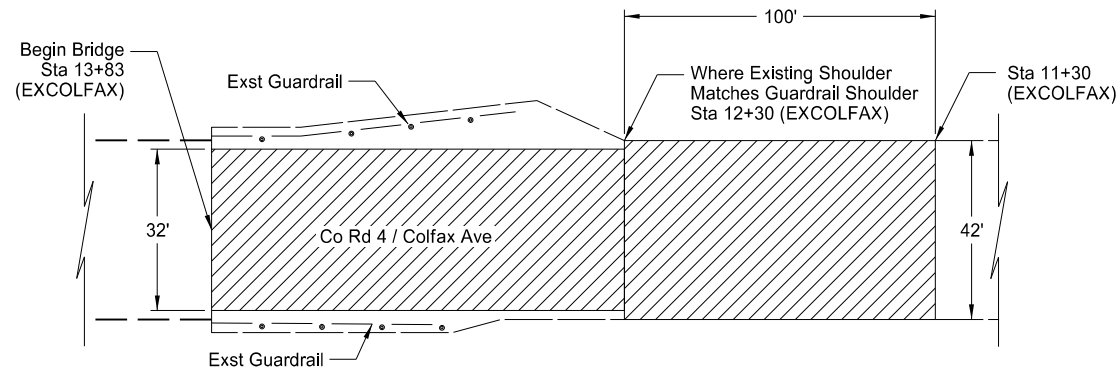

Milling Transition at Colfax Interchange Bridge
(Plan View)

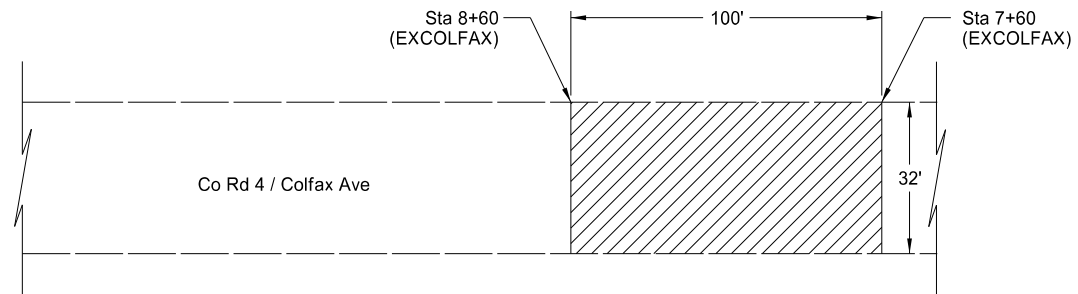

Milling Transition at Colfax Interchange Tie-In
(Plan View)

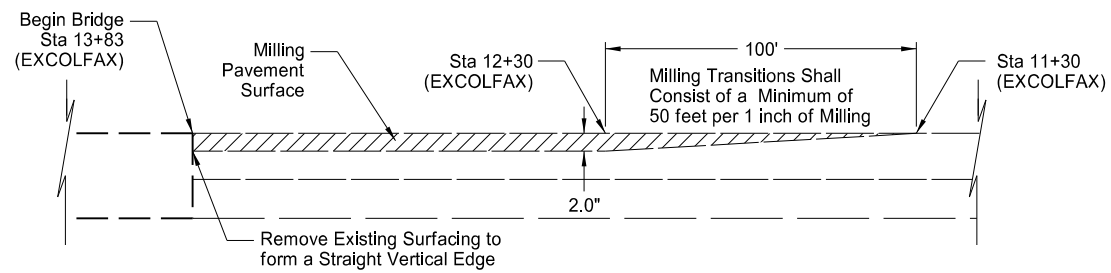

Milling Transition at Colfax Interchange Bridge
Profile View
(Not to Scale)

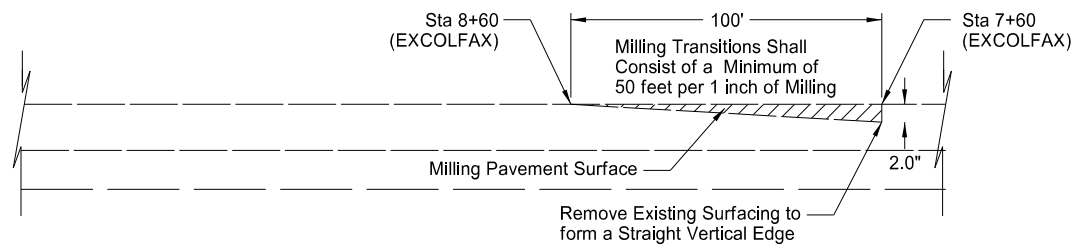

Milling Transition at Colfax Interchange Tie-In
Profile View
(Not to Scale)

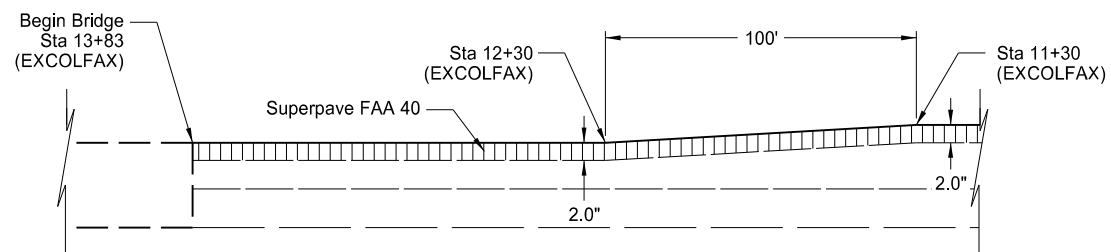

Paving Transition at Colfax Interchange Bridge
Profile View
(Not to Scale)

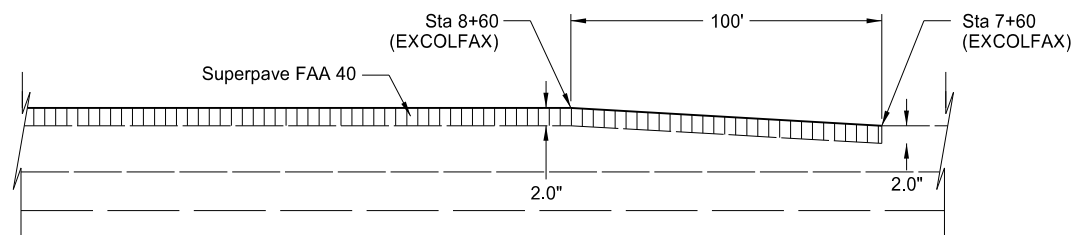

Paving Transition at Colfax Interchange Tie-In
Profile View
(Not to Scale)

This document was originally issued and sealed by Matt Lange, Registration Number PE- 6870, on 08/07/17 and the original document is stored at the North Dakota Department of Transportation

I-29 - N of Galchutt Exit to Christine Exit
Milling & Paving Transition Detail
Colfax Interchange

STATE	PROJECT NO.	SECTION NO.	SHEET NO.
ND	IM-8-029(170)033	20	4

Notes:
 1. Refer to Standard Drawing D-203-08 for grading details.

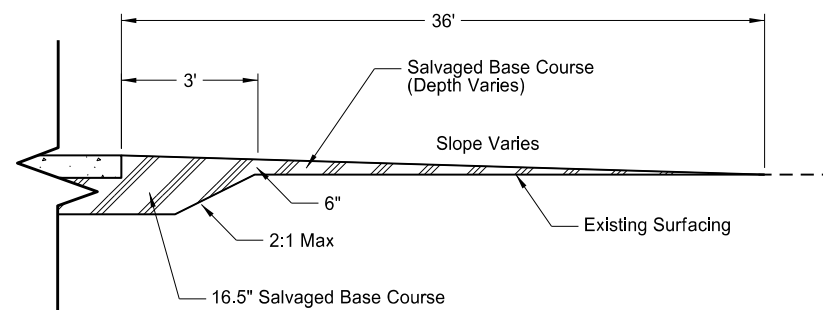
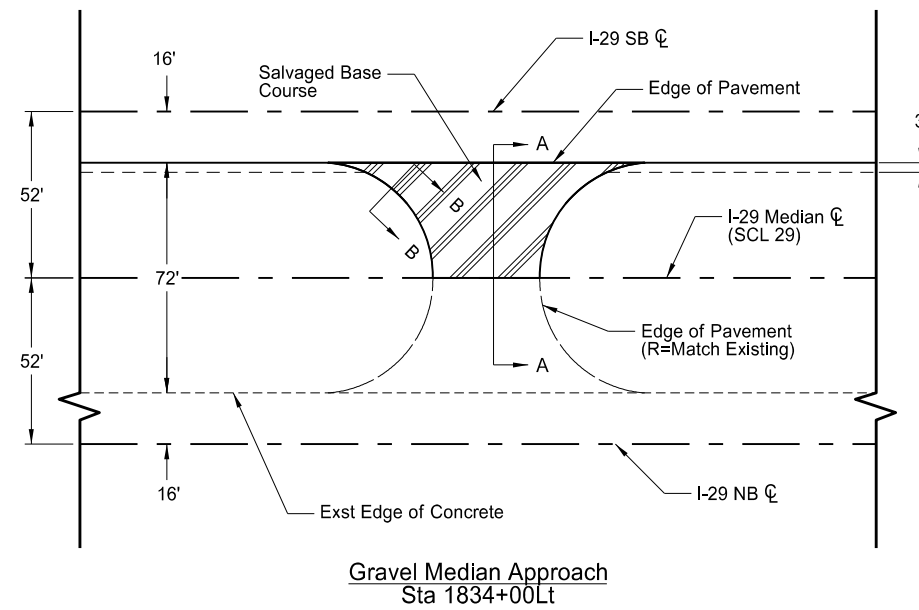

Section A-A
(Not to Scale)

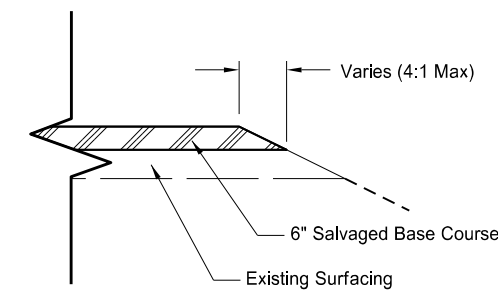

Section B-B
(Not to Scale)

This document was originally issued and sealed by Jonathan D. Bach, Registration Number PE- 9797, on 08/07/17 and the original document is stored at the North Dakota Department of Transportation

I-29 - N of Galchutt Exit to Christine Exit
 Median Approach Detail

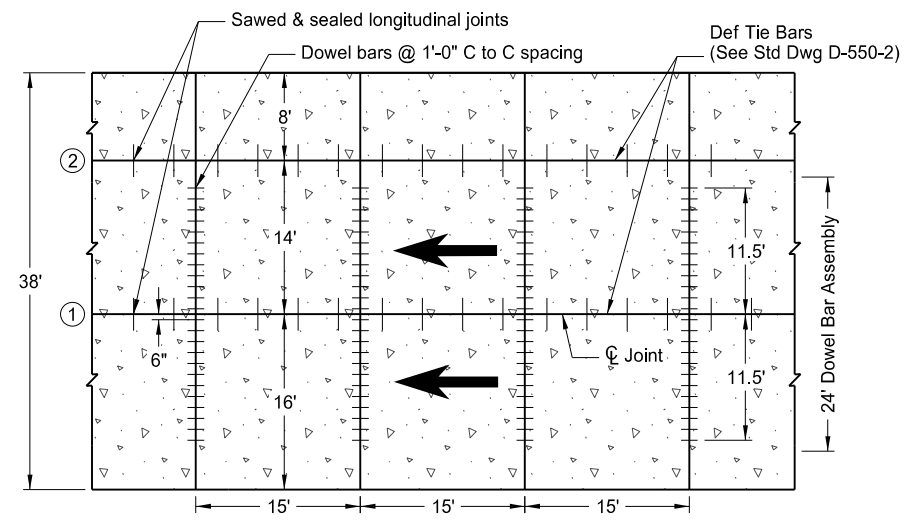

Alternate A: 15' Joint Spacing with PCC Shoulders

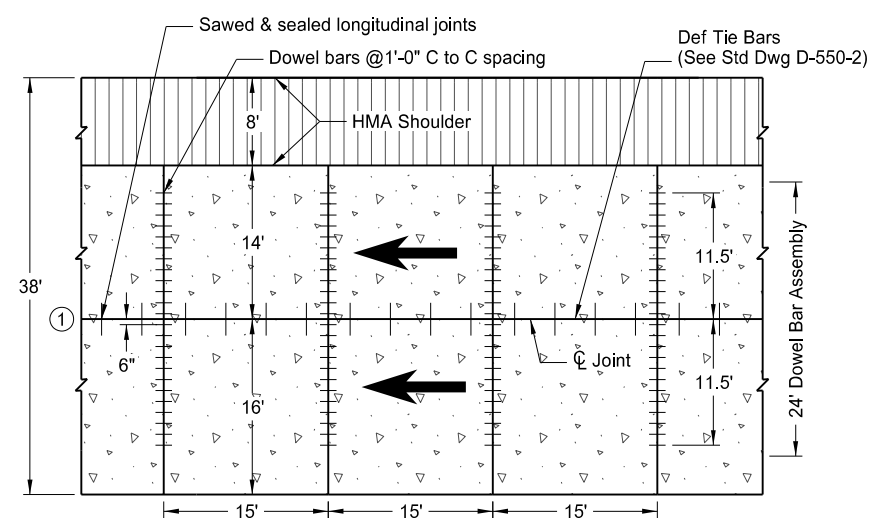

Alternate B: 15' Joint Spacing with Concrete Median Shoulder and 8' Asphalt Outside Shoulder

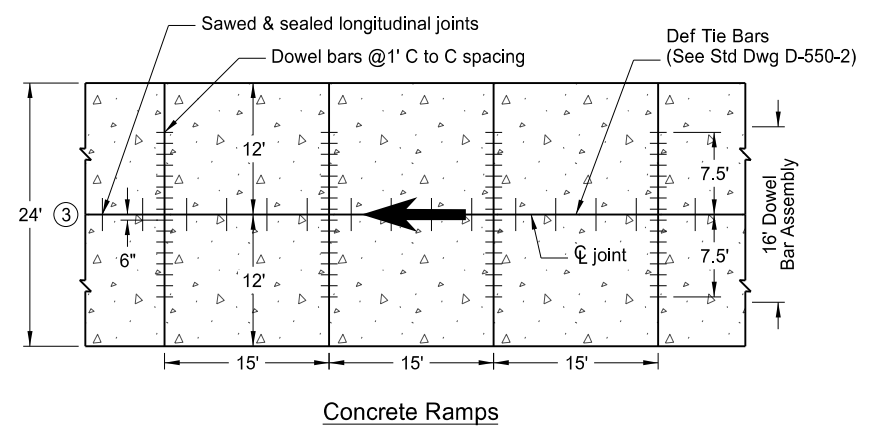

Concrete Ramps

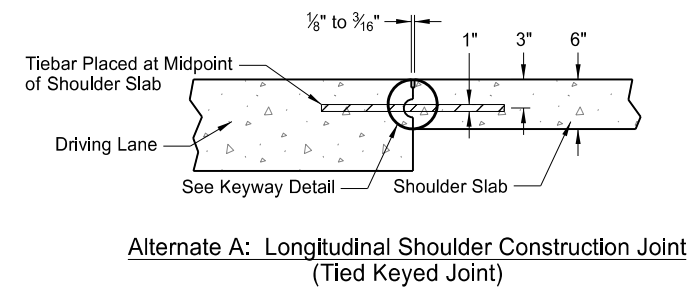

Alternate A: Longitudinal Shoulder Construction Joint (Tied Keyed Joint)

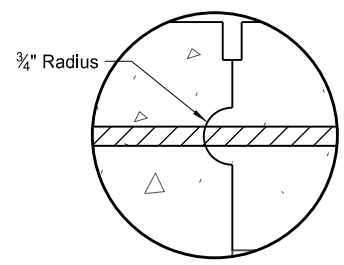

Alternate A: Keyway Detail

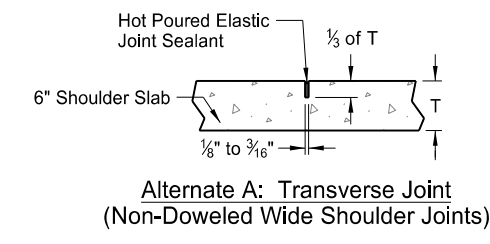

Alternate A: Transverse Joint (Non-Doweled Wide Shoulder Joints)

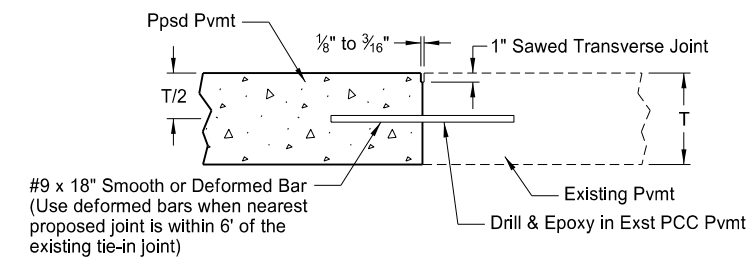

#9 x 18" Smooth or Deformed Bar (Use deformed bars when nearest proposed joint is within 6' of the existing tie-in joint)

Dowel Bar Installation in Existing Pavement (1'-0" C to C) (Transverse Joints)

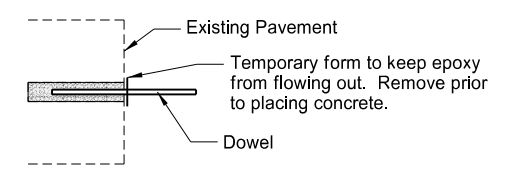
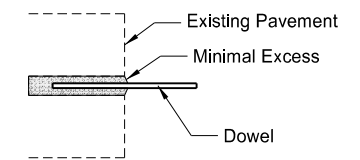
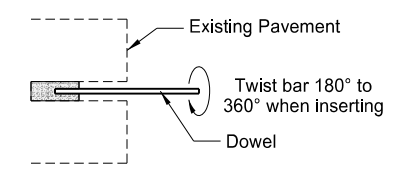

Placing Dowels in Existing Pavement (Smooth or Deformed Bars)

LONGITUDINAL JOINT TIE BAR SIZE, LENGTH, & SPACING				
Pavement Thickness	Location	Steel Grade	Bar Size & Length	Spacing
8.5"	①	40	#6 Bar x 36"	45"
		60	#5 Bar x 42"	45"
	③	40	#5 Bar x 30"	45"
		60	#4 Bar x 36"	45"
6"	②	40	#4 Bar x 24"	45"
		60	#3 Bar x 30"	45"

- Notes:
- 1) Dowel Bars shall be 1.25" x 18".
 - 2) See Section 90 for interstate ramp taper jointing.
 - 3) Place dowel bars at the vertical midpoint of existing PCC pavement.
 - 4) T = Pavement Thickness

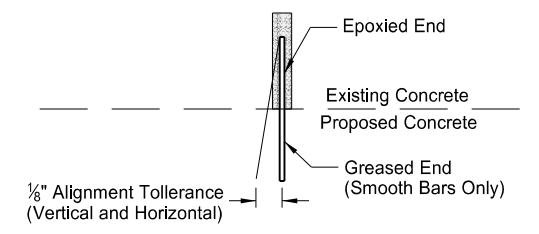

Dowel Alignment Tolerance

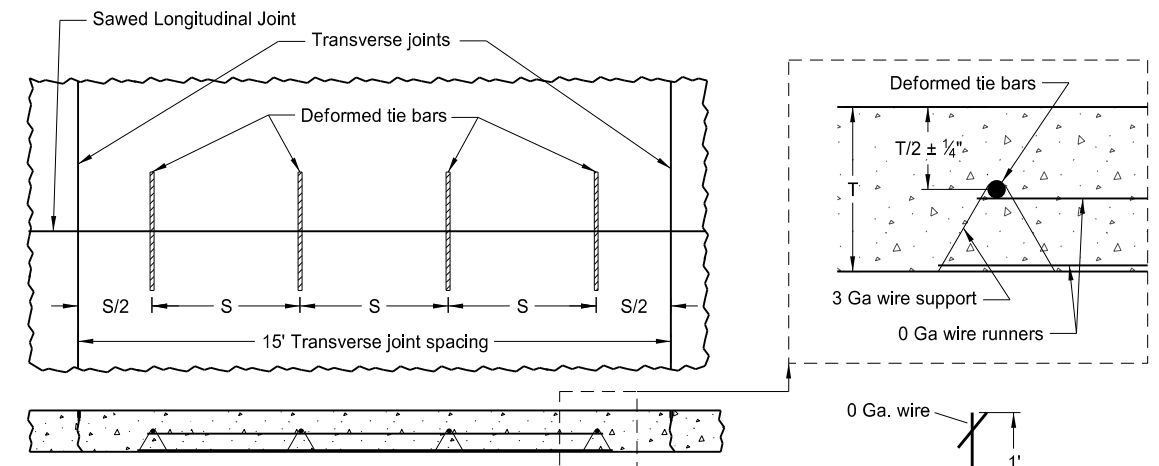

Longitudinal Tie Bar Assembly (One unit shown)

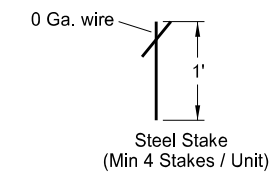
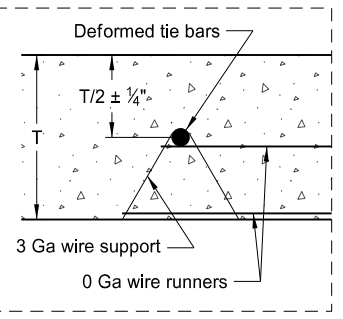

This document was originally issued and sealed by Matt Lange, Registration Number PE- 6870, on 08/07/17 and the original document is stored at the North Dakota Department of Transportation

I-29 - N of Galchutt Exit to Christine Exit
PCC Pavement Joint Details

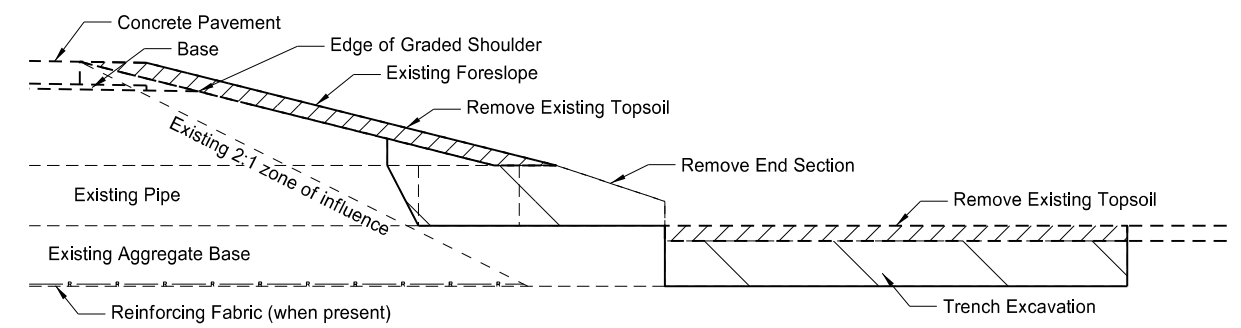

Removal Section
Cross Section View

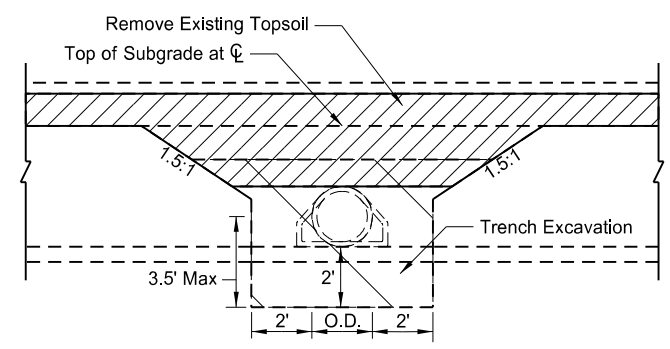

Removal Detail
Pipe Extension
Remove & Relay Pipe
New End Section
(Side View)

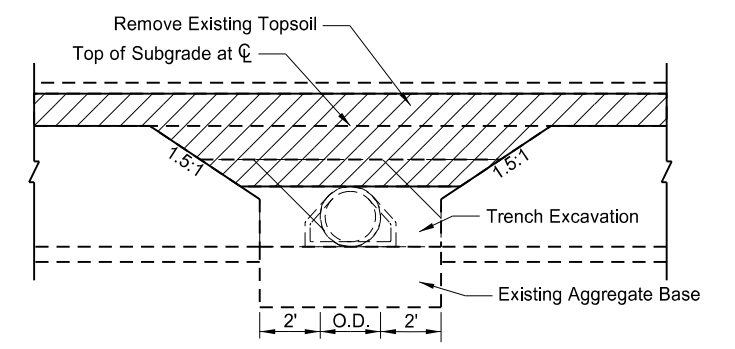

Removal Detail
Expose Utility
(Side View)

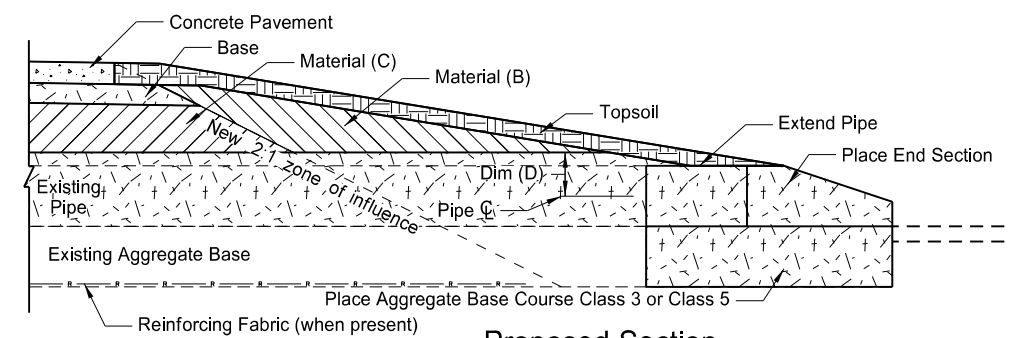

Proposed Section
Cross Section View

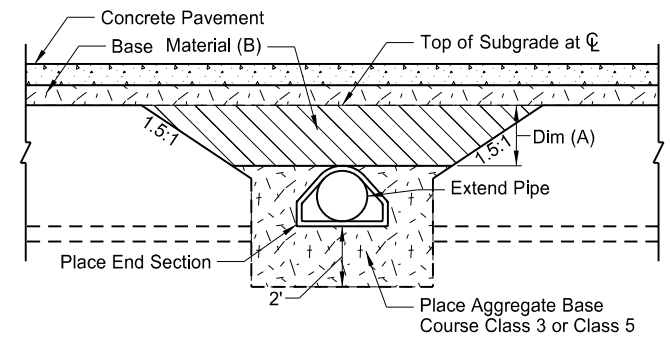

Backfill Detail
Pipe Extension
Remove & Relay Pipe
New End Section
(Side View - Topsoil not Shown)

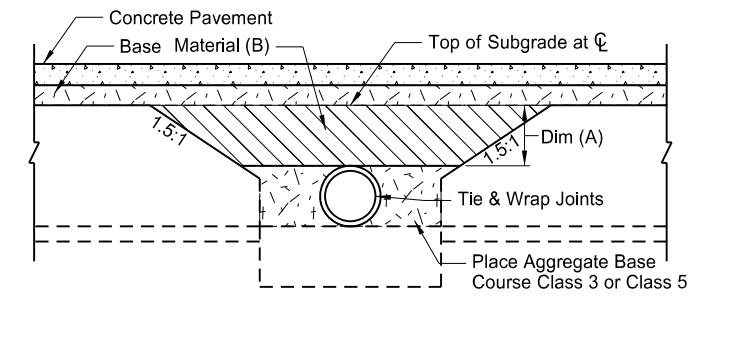

Backfill Detail
Expose Utility
(Side View - Topsoil not Shown)

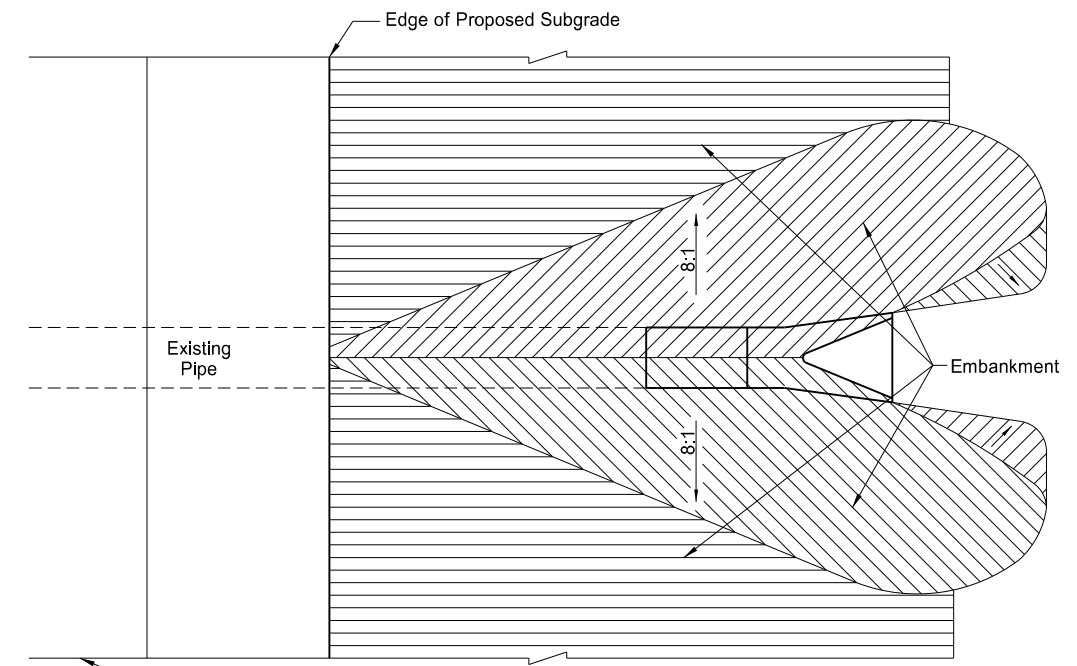

Proposed Section
Plan View

Pay Items

- 1) Pipe**
- 2) Remove & Relay Pipe - All Types & Sizes (when required)
- 3) Remove End Section and Place New End Section
- 4) Common Excavation-Type A (Paid for as "Reshaping Roadway")
- 5) Topsoil
- 6) Seeding
- 7) Mulching
- 8) Install Concrete Pipe Ties**

***Included in Pipe Pay Item**

- 1) Pipe
- 2) Trench excavation
- 3) Aggregate Base Course Class 3 or Class 5

****Included in Install Concrete Pipe Ties Pay Item**

- 1) Trench excavation
- 2) Pipe Ties
- 3) Type S2 Geotextile Fabric
- 4) Aggregate Base Course Class 3 or Class 5

Pipe Materials	Dim (A) <= 4 Feet		Backfill Dimension
	Material (B)	Material (C)	Dim (D)
Concrete	Embank or Aggr	Aggregate	0.5 O.D.
Metal and Plastic	Embank or Aggr	Aggregate	0.5 O.D.

Pipe Materials	Dim (A) > 4 Feet		Backfill Dimension
	Material (B)	Material (C)	Dim (D)
Concrete	Embankment	Embankment	0.5 O.D.
Metal and Plastic	Embankment	Embankment	0.5 O.D. + 1 Foot

Notes:

1. Embankment will be paid for as "Reshaping Roadway"
2. Aggregate may be either Class 3 or Class 5 Aggregate Base Course.

This document was originally issued and sealed by
 Matt Lange,
 Registration Number
 PE- 6870,
 on 08/07/17 and the original document is stored at the
 North Dakota Department
 of Transportation

I-29 - N of Galchutt Exit to Christine Exit
 Mainline C Pipe Extension Detail

255 0103 ECB TYPE 3										
Location	Alignment	Location of Surface Area to be Protected		Pipe Diameter (In)	No.	X (ft)	Y (ft)	Unit Quantity (SY)	Total Quantity (SY)	
		Station	Offset							
Interstate 29	SCL29	1770+80	Rt	24	1	10.5	19.6	22	22	
		1783+80	Rt	24	1	10.5	19.6	22	22	
		1804+80	Rt	30	1	11.6	20.5	25	25	
		1825+79	Rt	24	1	10.5	19.6	22	22	
		1849+74	Lt & Rt	30	2	11.6	20.5	25	50	
		1867+78	Lt	30*	1	9.1	23.5	25	25	
		1867+78	Rt	24	1	10.5	19.6	22	22	
		1885+78	Rt	24	1	10.5	19.6	22	22	
		1902+78	Lt & Rt	24	2	10.5	19.6	22	44	
		1902+78	Lt	24*	1	8.5	22.0	22	22	
		1920+78	Rt	24	1	10.5	19.6	22	22	
		1932+79	Rt	24	1	10.5	19.6	22	22	
		1950+72	Lt	36	1	12.7	21.2	27	27	
		1950+72	CL	Slotted Drain	1	21.5	24.0	57	57	
		1950+84	Lt	36	1	12.7	21.2	27	27	
		1950+84	CL	Slotted Drain	1	21.5	24.0	57	57	
		1959+78	Rt	24	1	10.5	19.6	22	22	
		1976+78	Rt	24	1	10.5	19.6	22	22	
		1996+76	Rt	24	1	10.5	19.6	22	22	
		2006+91	Lt	42	3	13.3	21.2	28	84	
		2020+76	Rt	24	1	10.5	19.6	22	22	
		2033+75	Rt	24	1	10.5	19.6	22	22	
		2046+75	Rt	24	1	10.5	19.6	22	22	
		2058+76	Lt & Rt	36	2	12.7	21.2	27	54	
		2058+76	Lt	36*	1	9.7	23.2	27	27	
		2072+95	Rt	24	1	10.5	19.6	22	22	
		2090+94	Rt	24	1	10.5	19.6	22	22	
		2108+94	Lt	24	1	10.5	19.6	22	22	
		2108+94	Lt	24*	1	8.5	22.0	22	22	
		2123+92	Lt	30	1	11.6	20.5	25	25	
		2123+92	Lt	30*	1	9.1	23.5	25	25	
		2138+94	Lt	30	1	11.6	20.5	25	25	
		2138+94	Lt	30*	1	9.1	23.5	25	25	
		2156+91	Lt & Rt	24	2	10.5	19.6	22	44	
		2156+91	Lt	24*	1	8.5	22.0	22	22	
		2166+93	Lt	36	1	12.7	21.2	27	27	
		2173+94	Lt	24	2	10.5	19.6	22	44	
		2189+93	Lt	24	1	10.5	19.6	22	22	
		2189+93	Lt	24*	1	8.5	22.0	22	22	
		2202+91	Rt	24	1	10.5	19.6	22	22	
2209+92	Lt	48	1	13.8	22.0	30	30			
2209+92	CL	Median Drain	1	24.0	24.0	63	63			
2219+91	Lt	24	1	10.5	19.6	22	22			
2219+91	Lt	24*	1	8.5	22.0	22	22			
2229+91	Lt	24	1	10.5	19.6	22	22			
2229+91	Lt	24*	1	8.5	22.0	22	22			
2245+90	Lt	42	1	13.3	21.2	28	28			
2254+91	Lt	24	1	10.5	19.6	22	22			
2254+91	Lt	24*	1	8.5	22.0	22	22			
2277+90	Lt & Rt	24	2	10.5	19.6	22	44			
2277+90	Lt	24*	1	8.5	22.0	22	22			
2290+30	Lt	24	1	10.5	19.6	22	22			
2299+20	Lt	36	1	12.7	21.2	27	27			
2299+40	Lt	36	1	12.7	21.2	27	27			
2312+32	Lt	24	1	10.5	19.6	22	22			
2312+32	Lt	24*	1	8.5	22.0	22	22			
2324+31	Lt	24	1	10.5	19.6	22	22			
2324+31	Lt	24*	1	8.5	22.0	22	22			
2325+80	Lt	36	1	12.7	21.2	27	27			
Colfax Interchange	EXCOLSWR	17+03	Lt & Rt	36	2	12.7	19.2	24	48	
		17+11	Lt & Rt	36	2	12.7	19.2	24	48	
		EXCOLNWR	6+26	Lt & Rt	24	2	10.5	17.6	20	40
Walcott Interchange	EXCOLNER	6+62	Lt	24	1	10.5	17.6	20	20	
		EX60SWR	15+48	Rt	30	1	11.6	18.5	22	22
		EX60NWR	8+13	Lt & Rt	24	2	10.5	17.6	20	40
Christine Intchg	EX60SER	12+03	Lt	24	1	10.5	17.6	20	20	
		EX60NER	6+88	Lt	24	1	10.5	17.6	20	20
		EX58SWR	17+29	Lt & Rt	36	2	12.7	19.2	24	48
Proposed Ramp Connections	RC 37_N_SER	109+68	Ahd & Bk	12	2	9.5	18.0	19	38	
		207+63	Ahd & Bk	12	2	9.5	18.0	19	38	
		309+55	Ahd & Bk	12	2	9.5	18.0	19	38	
		309+67	Ahd & Bk	12	2	9.5	18.0	19	38	
		RC 42_N_SER	421+34	Ahd & Bk	12	2	9.5	18.0	19	38
Proposed Ramp Connections	RC 44_N_SER	509+62	Ahd & Bk	12	2	9.5	18.0	19	38	
Total = 2,242										

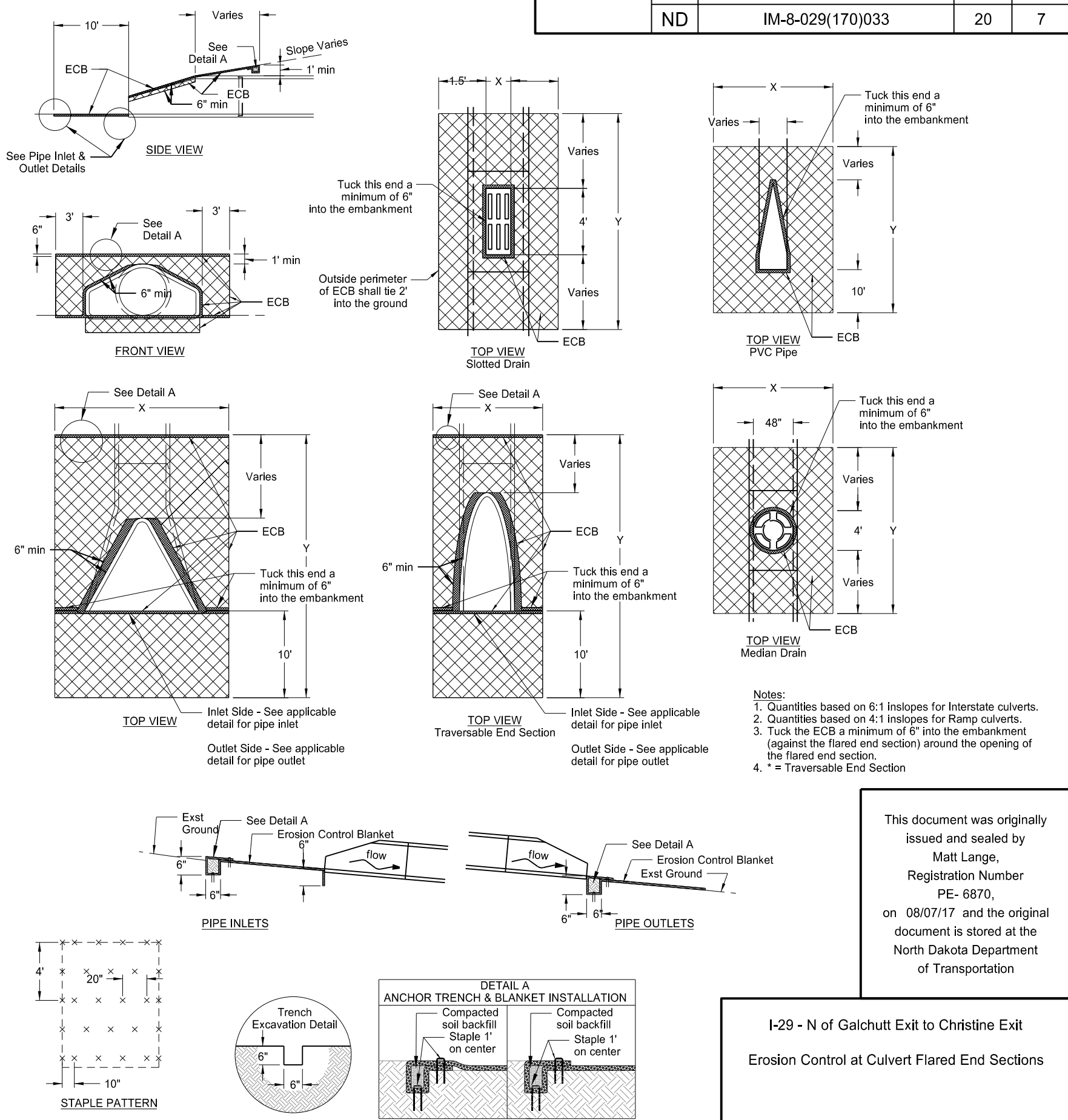

This document was originally issued and sealed by Matt Lange, Registration Number PE- 6870, on 08/07/17 and the original document is stored at the North Dakota Department of Transportation

I-29 - N of Galchutt Exit to Christine Exit
Erosion Control at Culvert Flared End Sections

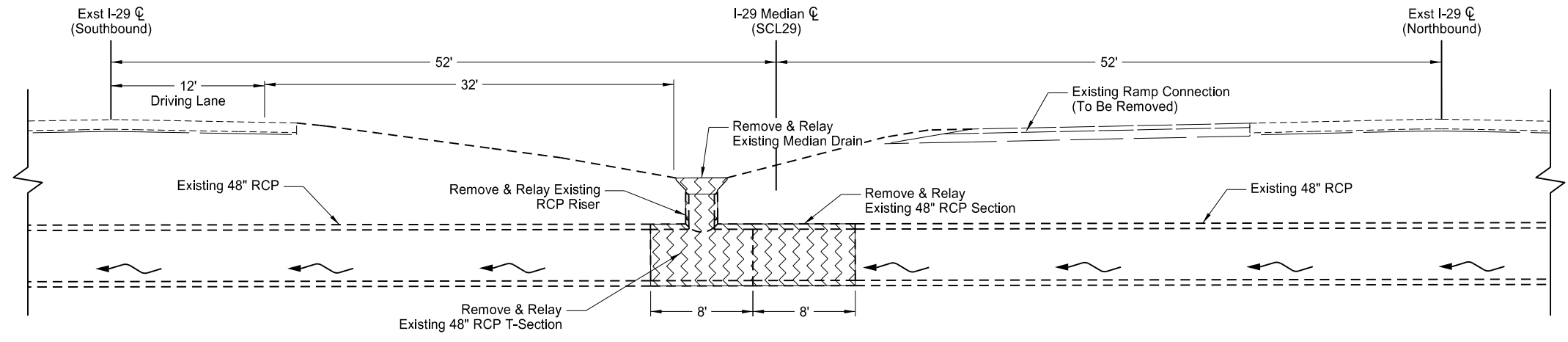

Removal Typical Section - Median Drain
 Walcott Interchange Southeast Ramp Connection
 Sta 305+44 (RC_42_N_SER)

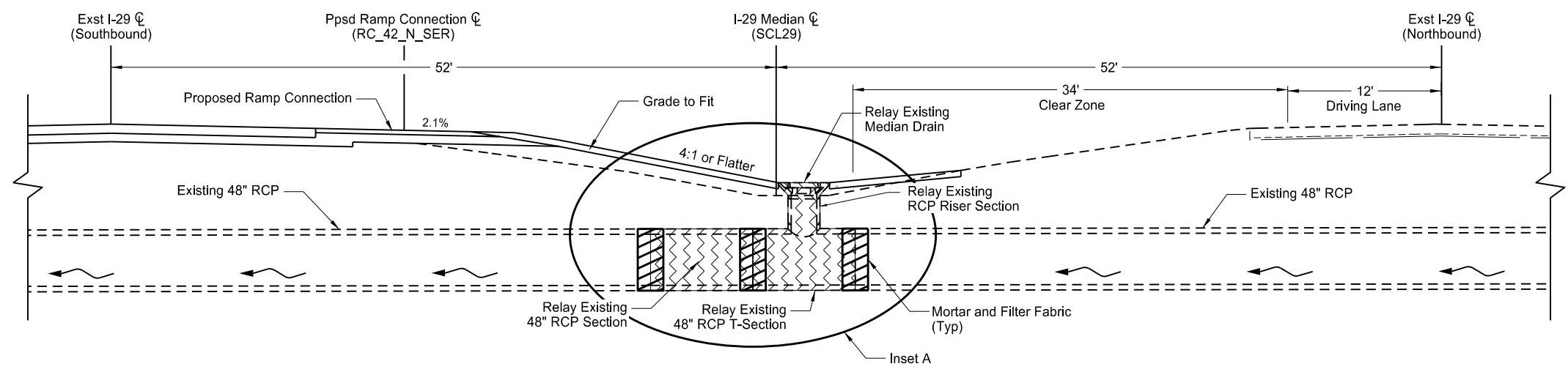

Proposed Typical Section - Median Drain
 Walcott Interchange Southeast Ramp Connection
 Sta 305+44 (RC_42_N_SER)

Remove & Relay
 Mortar & Filter Fabric

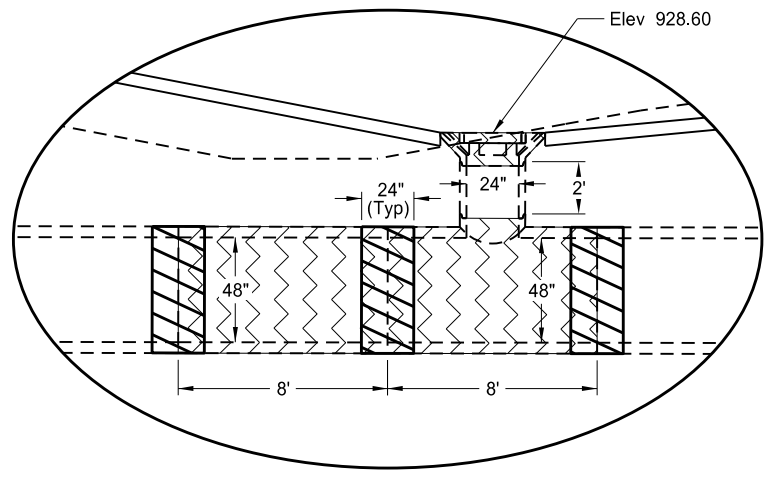

Inset A

- Notes:**
1. Refer to Standard Drawing D-722-7 for additional details.
 2. Refer to Section 60 for proposed quantities.
 3. Existing 8" RCP pipe segments are assumed lengths.
 4. Use Mortar and filter fabric to fill all open joints.

This document was originally issued and sealed by
 Matt Lange,
 Registration Number
 PE- 6870,
 on 08/11/17 and the original document is stored at the
 North Dakota Department
 of Transportation

I-29 - N of Galchutt Exit to Christine Exit
 Median Drain Detail

STATE	PROJECT NO.	SECTION NO.	SHEET NO.
ND	IM-8-029(170)033	20	9

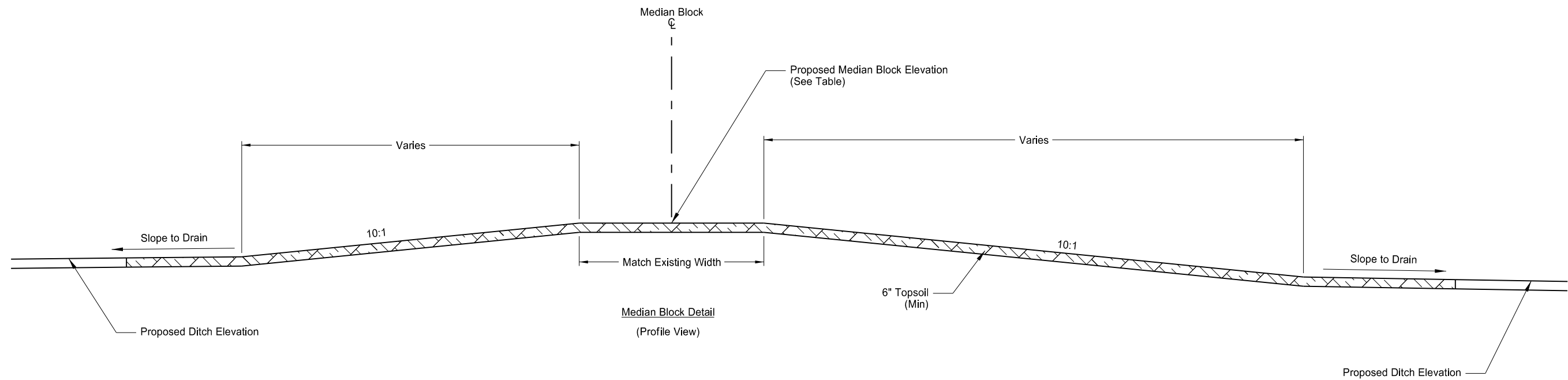

MEDIAN BLOCKS		
Location		Elevation
Station	Offset	
1771+43	Mdn	949.61
2021+19	Mdn	941.75
2034+34	Mdn	940.29
2047+38	Mdn	939.21
2139+74	Mdn	932.84
2203+63	Mdn	931.09
2312+87	Mdn	928.35

This document was originally issued and sealed by Jonathan D. Bach, Registration Number PE- 9797, on 08/07/17 and the original document is stored at the North Dakota Department of Transportation

I-29 - N of Galchutt Exit to Christine Exit
Median Block Detail

Notes:

1. Include all costs of the labor, equipment, and materials to construct the median blocks in the price bid for "Reshaping Roadway".

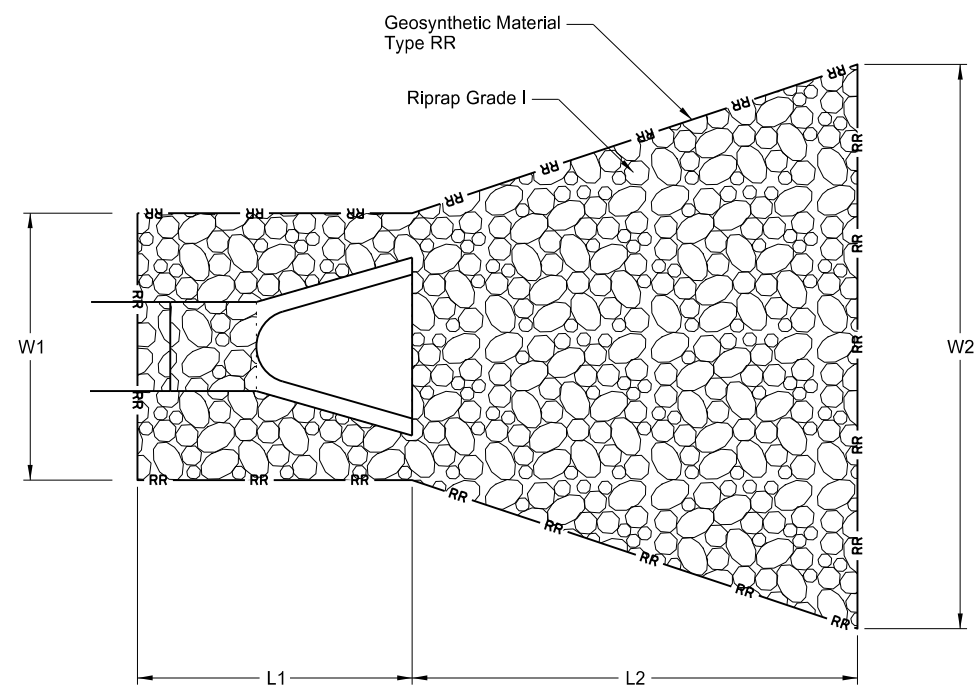

Riprap Detail
Plan View

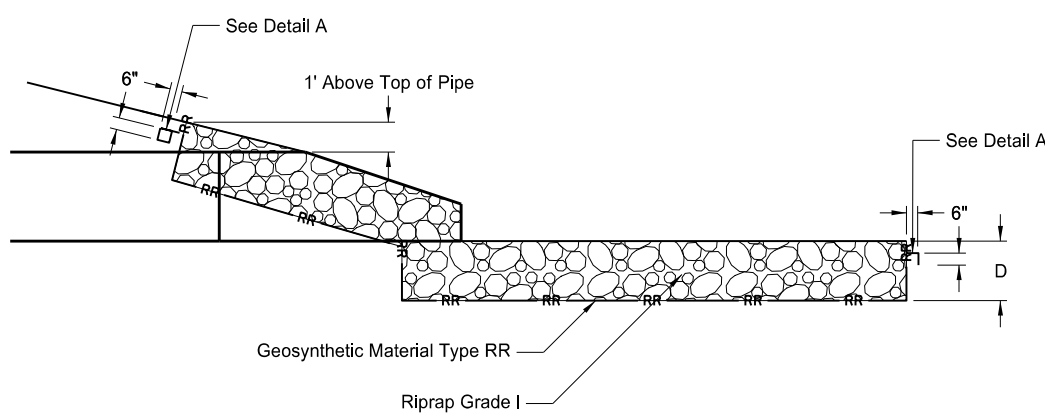
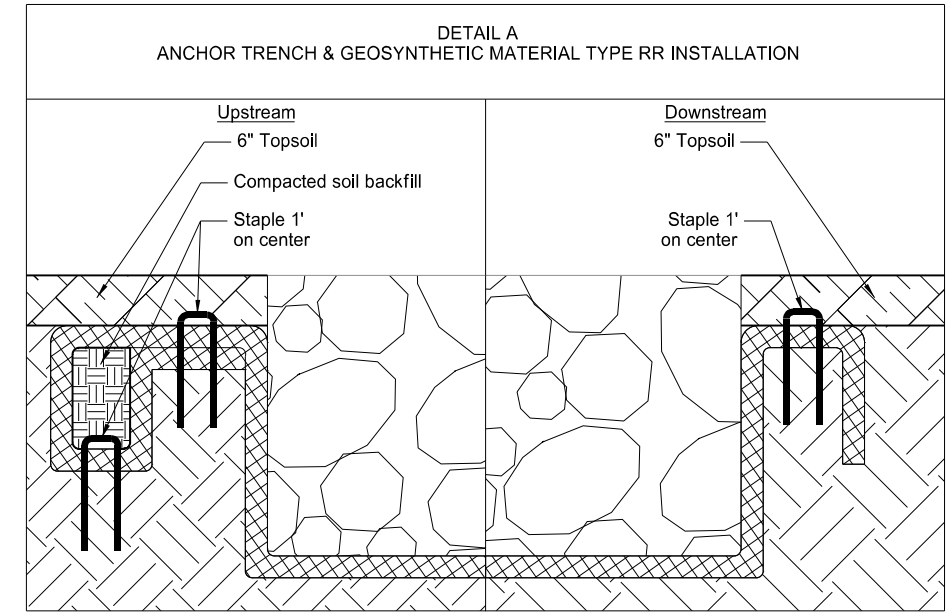

Riprap Detail
Profile View

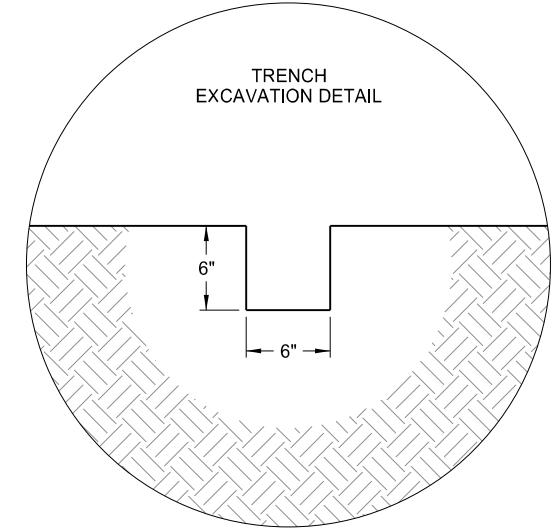

RIPRAP AND GEOSYNTHETIC MATERIAL										
Location of Surface Area to be Protected			Pipe Diameter	L1	L2	W1	W2	D	256 0100 RIPRAP GRADE I	709 0155 GEOSYNTHETIC MATERIAL TYPE RR
Sta	Offset	Type	(IN)	(FT)	(FT)	(FT)	(FT)	(IN)	(CY)	(SY)
2217+16	Lt	Ramp Cl	30	21.0	12.5	7.5	15.8	22	21	52

This document was originally issued and sealed by John W. Wirres, Registration Number PE- 4449, on 08/07/17 and the original document is stored at the North Dakota Department of Transportation

I-29 - N of Galchutt Exit to Christine Exit
Riprap Detail

STATE	PROJECT NO.	SECTION NO.	SHEET NO.
ND	IM-8-029(170)033	20	11

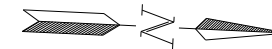
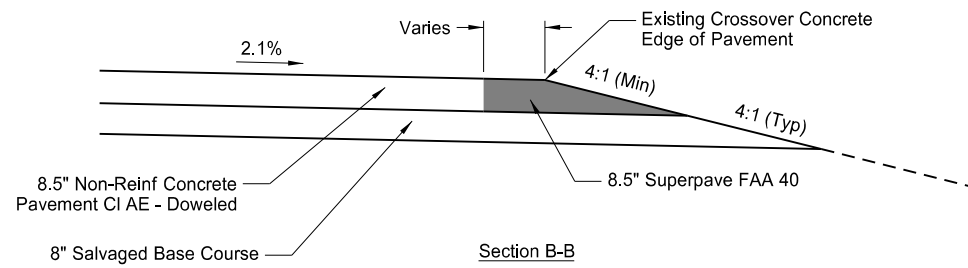
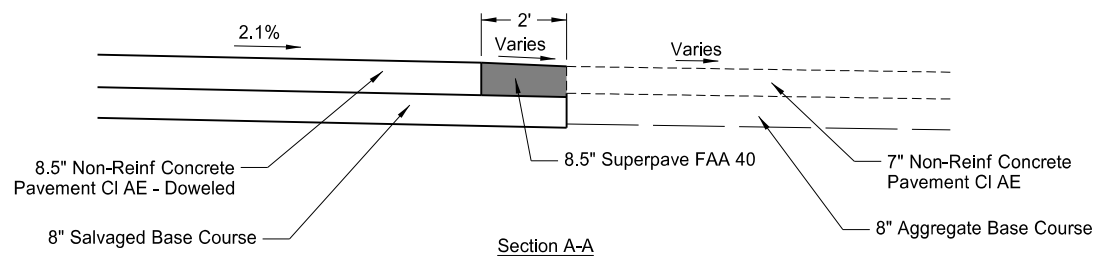
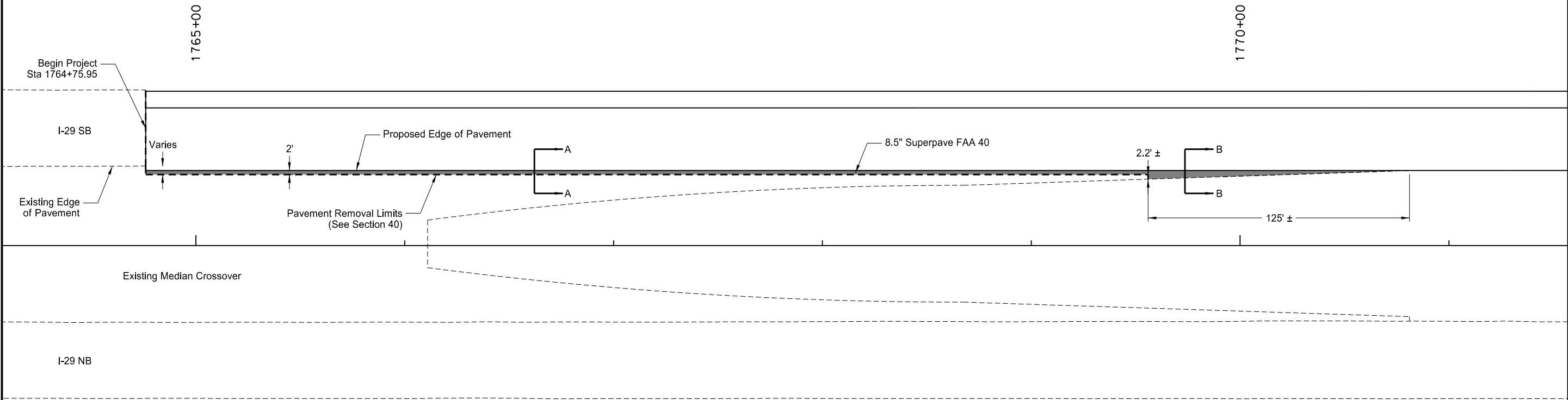

This document was originally issued and sealed by
 Matt Lange,
 Registration Number
 PE- 6870,
 on 08/07/17 and the original document is stored at the
 North Dakota Department
 of Transportation

- Notes:
- 8.5" Superpave FAA 40 will be placed in a minimum of 2 lifts.
 - Ordinary Compaction (Section 430.04 I.3 of the Standard Specifications) is specified for this pavement.

I-29 - N of Galchutt Exit to Christine Exit
 South Median Crossover Paving Detail

STATE	PROJECT NO.	SECTION NO.	SHEET NO.
ND	IM-8-029(170)033	20	12

SPEC	CODE	BID ITEM	QTY	UNIT
203	0138	COMMON EXCAVATION-SUBCUT		
		Discretionary Subcut	1,561	CY
302	0100	SALVAGED BASE COURSE		
		Discretionary Subcut	2,926	TON
709	0151	GEOSYNTHETIC MATERIAL TYPE R1		
		Discretionary Subcut	3,298	SY

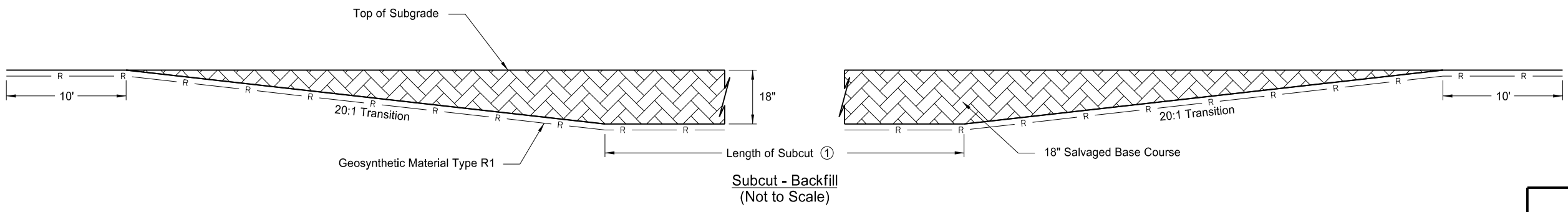
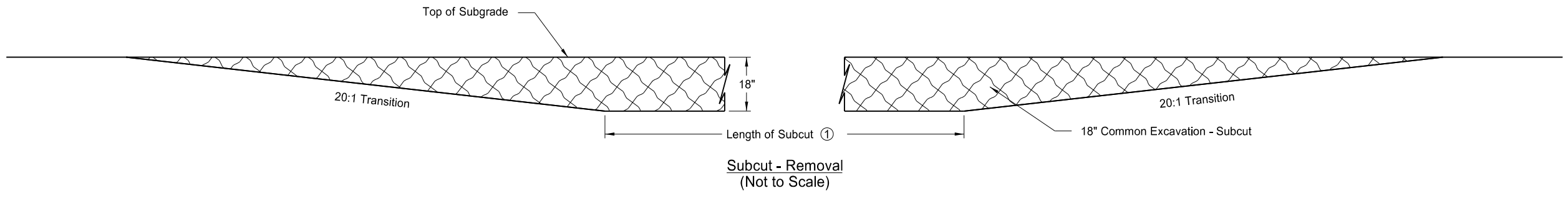

This document was originally issued and sealed by
 Matt Lange,
 Registration Number
 PE- 6870,
 on 08/07/17 and the original document is stored at the
 North Dakota Department
 of Transportation

I-29 - N of Galchutt Exit to Christine Exit
 Subcut Detail

Notes:
 ① Quantities based on 500 lineal feet of discretionary subcut (53' graded width)

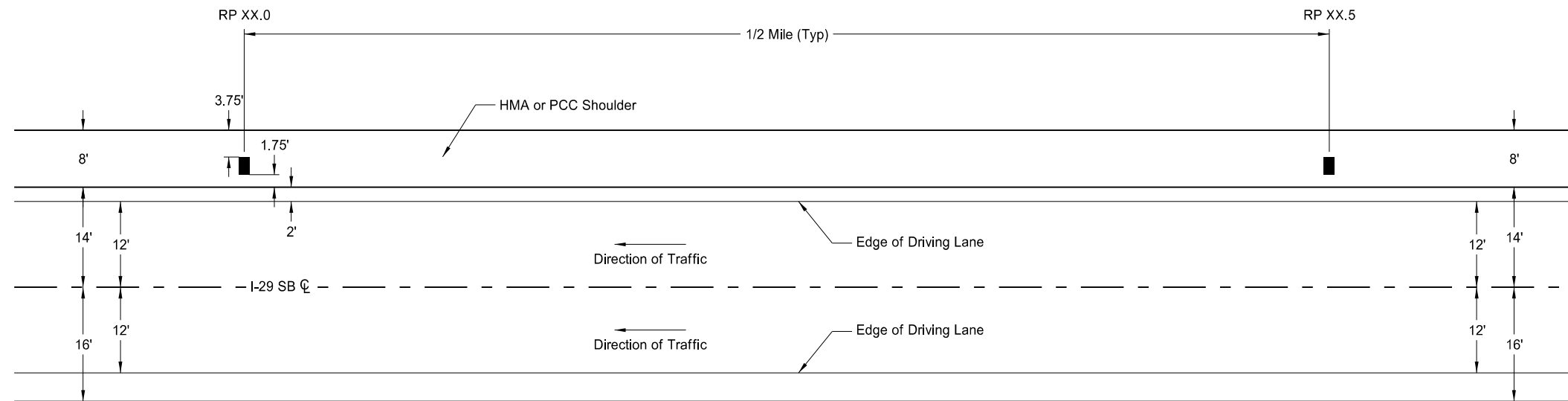

Speed Measurement Pavement Marking Detail
Plan View

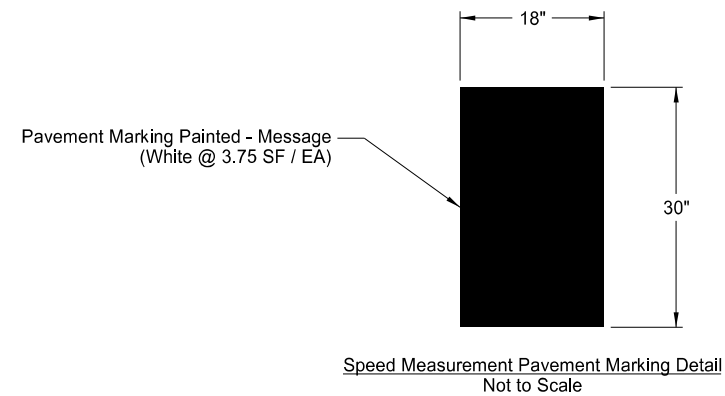

SPEED MEASUREMENT PAVEMENT MARKING LOCATIONS
RP 33.5
RP 34.0
RP 34.5
RP 35.0
RP 35.5
RP 36.0
RP 36.5
RP 37.0
RP 37.5
RP 38.0
RP 38.5
RP 39.0
RP 39.5
RP 40.0
RP 40.5
RP 41.0
RP 41.5
RP 42.0
RP 42.5
RP 43.0
RP 43.5
RP 44.0

Notes:
1. Refer to Section 10 for quantities.

This document was originally issued and sealed by
Matt Lange,
Registration Number
PE- 6870,
on 08/07/17 and the original document is stored at the
North Dakota Department
of Transportation

I-29 - North Galchutt Exit to Christine Exit
Speed Measurement Pavement Markings

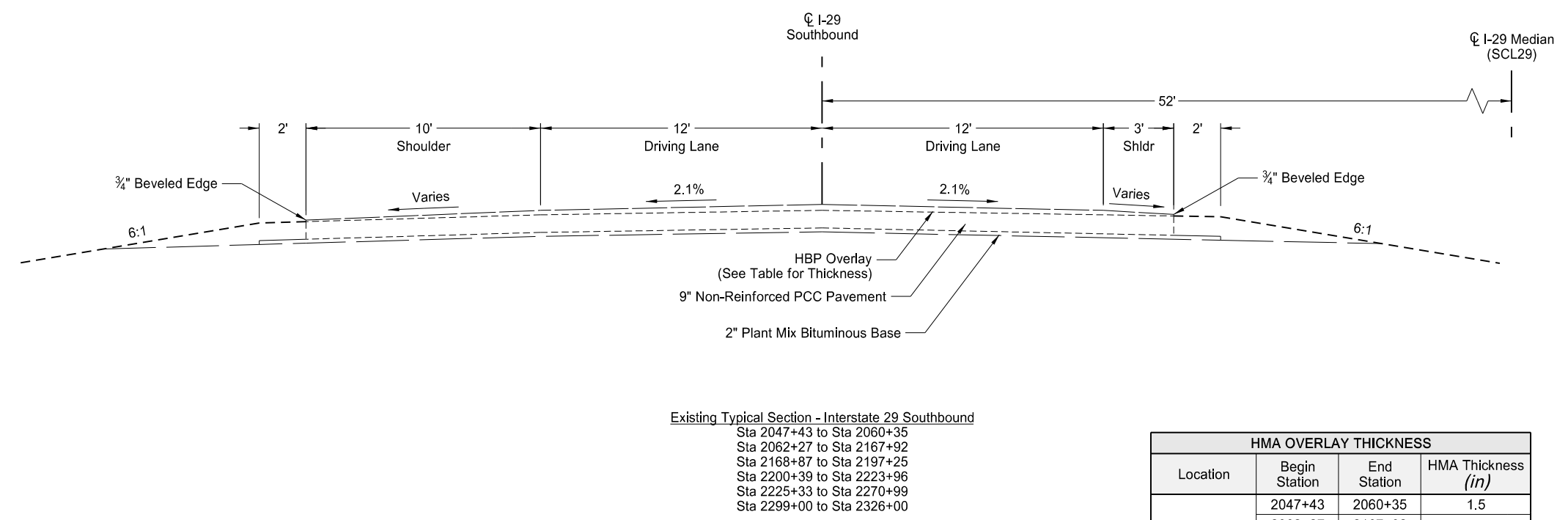
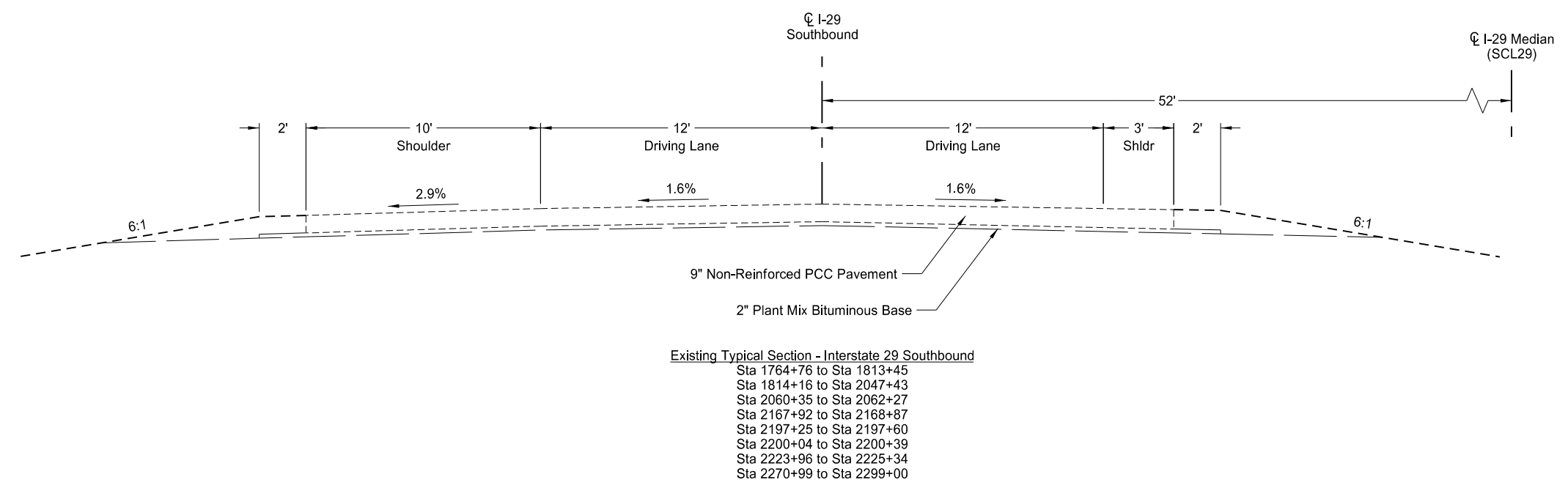

HMA OVERLAY THICKNESS			
Location	Begin Station	End Station	HMA Thickness (in)
Interstate 29	2047+43	2060+35	1.5
	2062+27	2167+92	3
	2168+87	2197+25	
	2200+39	2223+96	
	2225+33	2270+99	2
2299+00	2326+00		

This document was originally issued and sealed by Jonathan D. Bach, Registration Number PE- 9797, on 08/07/17 and the original document is stored at the North Dakota Department of Transportation

I-29 - N of Galchutt Exit to Christine Exit
 Existing Typical Sections
 Interstate 29 Southbound (SCL29)

STATE	PROJECT NO.	SECTION NO.	SHEET NO.
ND	IM-8-029(170)033	30	2

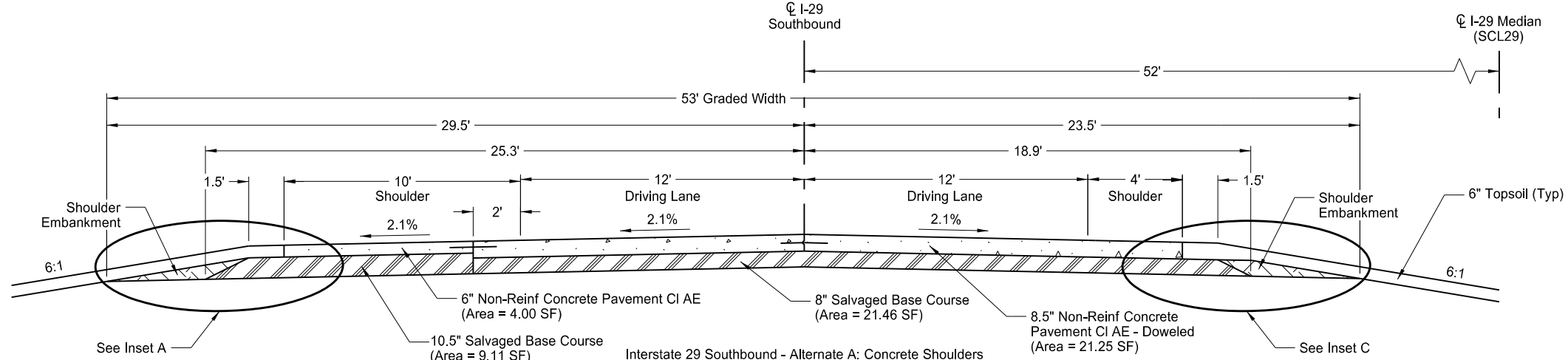

Interstate 29 Southbound - Alternate A: Concrete Shoulders
 Sta 1764+76 to Sta 1813+25
 Sta 1814+36 to Sta 1933+60
 Sta 1945+91 to Sta 1965+05
 Sta 1973+90 to Sta 2138+27
 Sta 2150+58 to Sta 2163+42
 Sta 2172+27 to Sta 2197+40
 Sta 2200+24 to Sta 2201+87
 Sta 2214+17 to Sta 2233+30
 Sta 2242+31 to Sta 2308+70
 Sta 2321+01 to Sta 2326+00

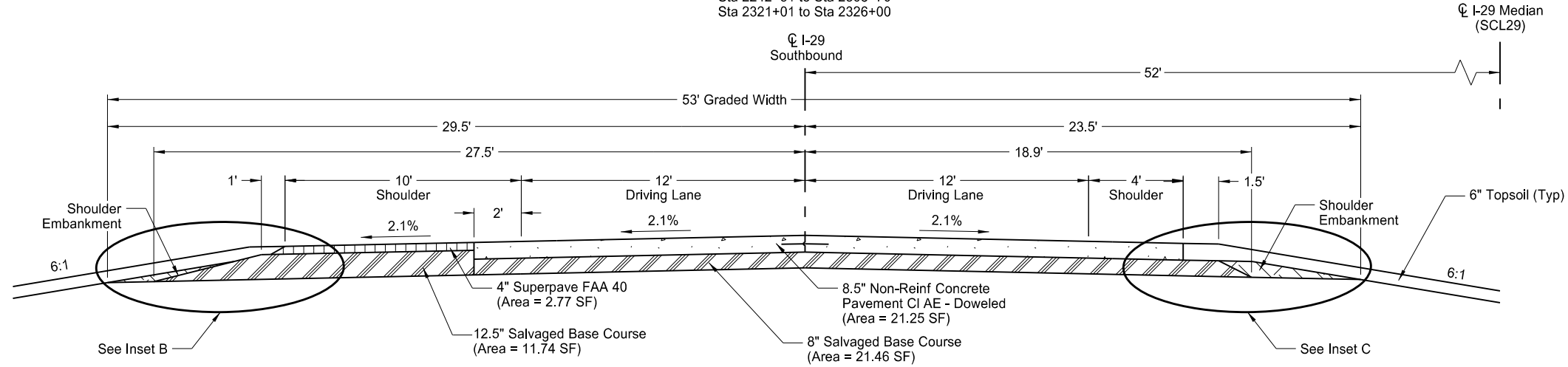

Interstate 29 Southbound - Alternate B: Concrete Median Shoulder w/ 8' Asphalt Outside Shoulder
 Sta 1764+76 to Sta 1813+25
 Sta 1814+36 to Sta 1933+60
 Sta 1945+91 to Sta 1965+05
 Sta 1973+90 to Sta 2138+27
 Sta 2150+58 to Sta 2163+42
 Sta 2172+27 to Sta 2197+40
 Sta 2200+24 to Sta 2201+87
 Sta 2214+17 to Sta 2233+30
 Sta 2242+31 to Sta 2308+70
 Sta 2321+01 to Sta 2326+00

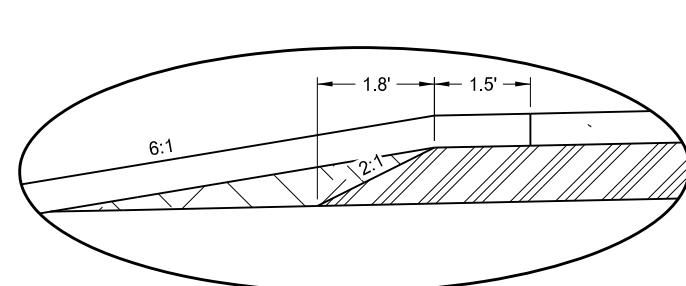

Inset A

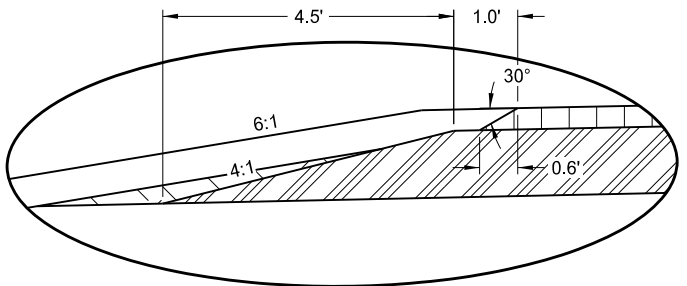

Inset B

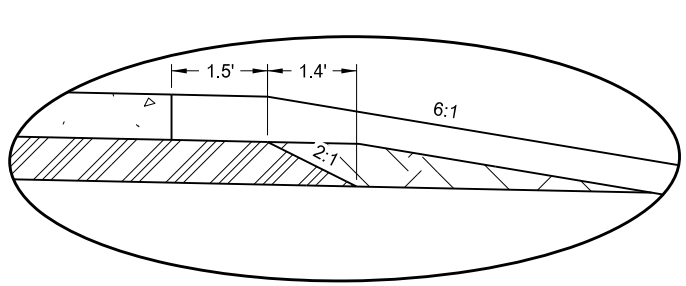

Inset C

This document was originally issued and sealed by Jonathan D. Bach, Registration Number PE- 9797, on 08/07/17 and the original document is stored at the North Dakota Department of Transportation

I-29 - N of Galchutt Exit to Christine Exit
 Proposed Typical Sections
 Interstate 29 Southbound (SCL29)

STATE	PROJECT NO.	SECTION NO.	SHEET NO.
ND	IM-8-029(170)033	30	3

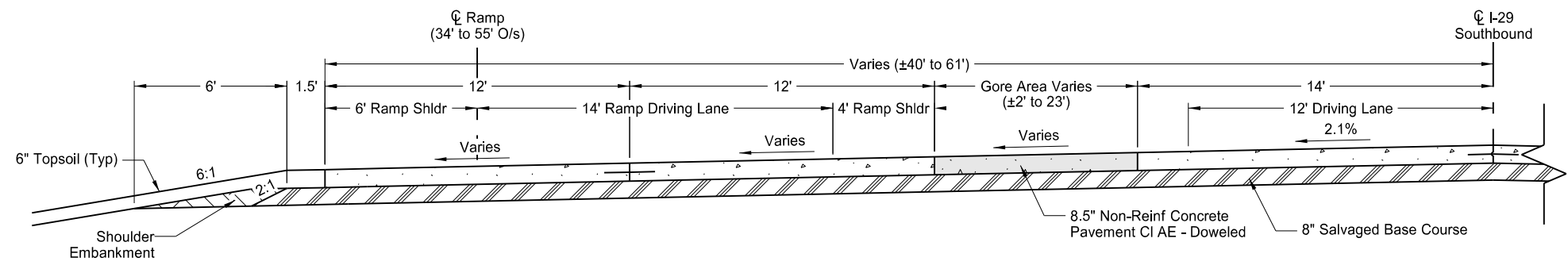
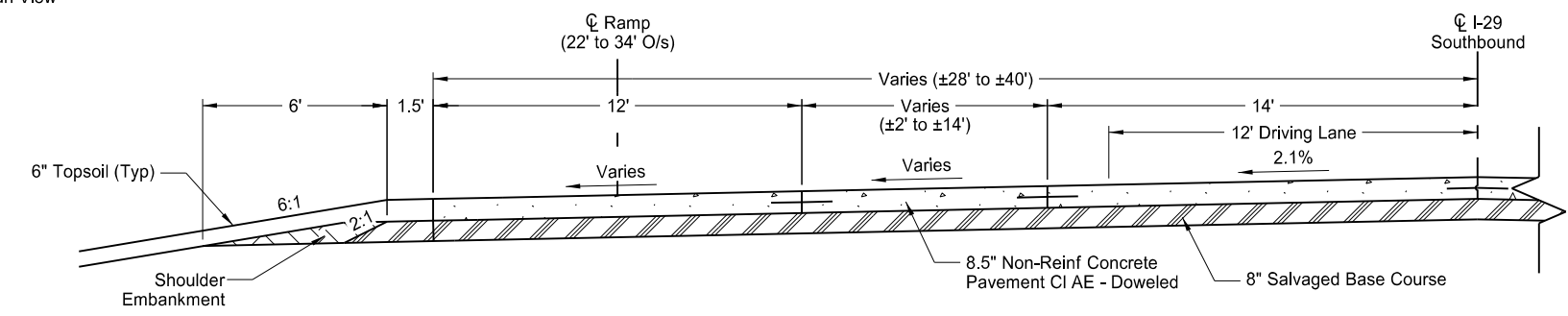
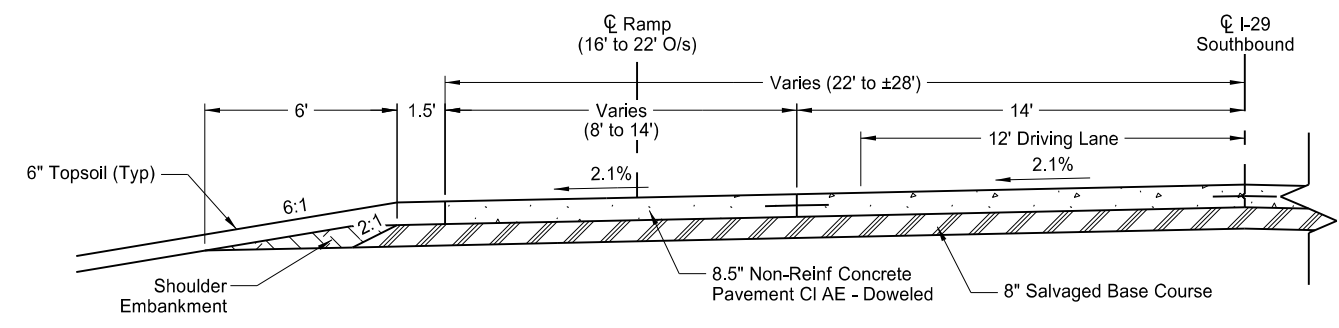
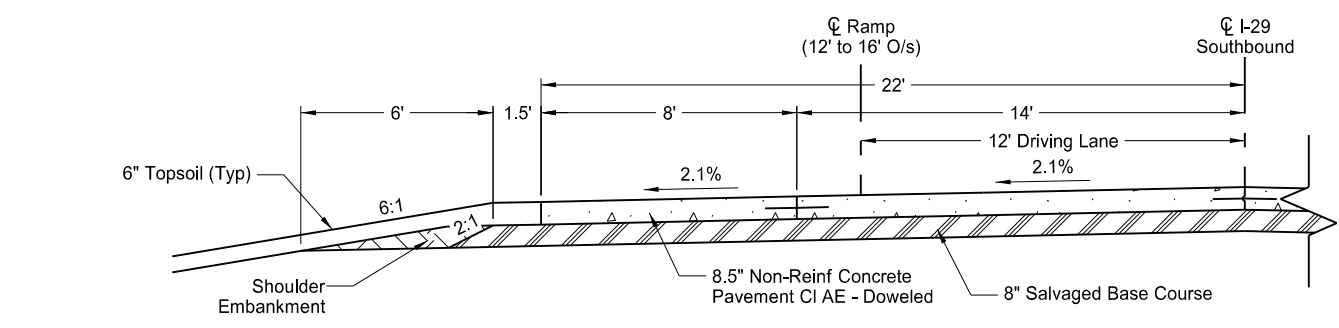
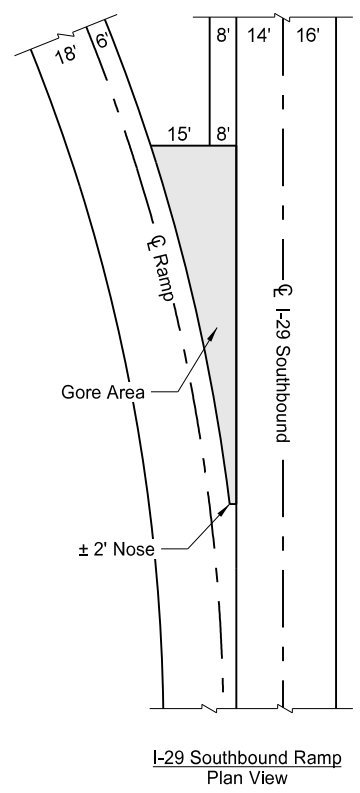

This document was originally issued and sealed by Jonathan D. Bach, Registration Number PE- 9797, on 08/07/17 and the original document is stored at the North Dakota Department of Transportation

I-29 - N of Galchutt Exit to Christine Exit
Proposed Typical Sections
Interstate 29 Southbound Ramp Tapers (SCL29)

	STATE	PROJECT NO.	SECTION NO.	SHEET NO.
	ND	IM-8-029(170)033	30	4

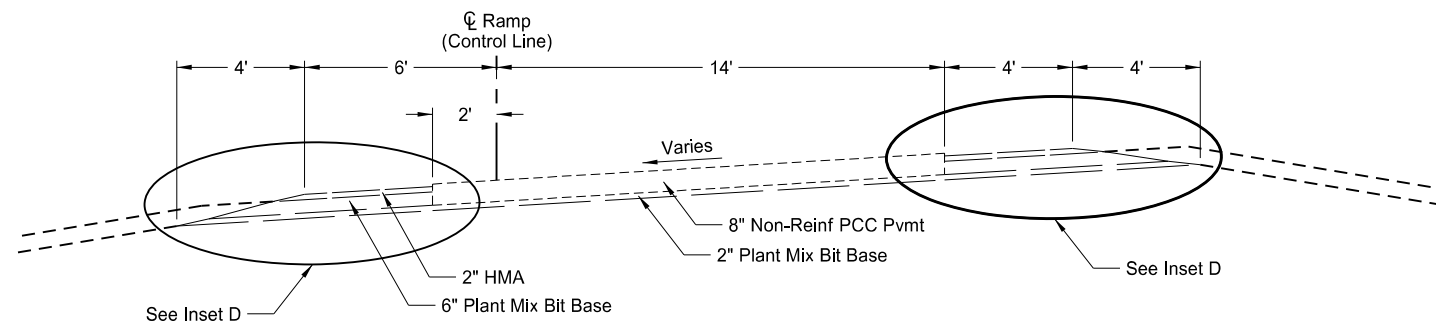

Existing Typical Section - Colfax & Walcott Interchange Southbound Ramps
 Sta 12+29 to Sta 22+23 (EXCOLSWR)
 Sta 1+13 to Sta 10+82 (EXCOLNWR)
 Sta 12+68 to Sta 21+61 (EX60SWR)
 Sta 0+92 to Sta 11+05 (EX60NWR)

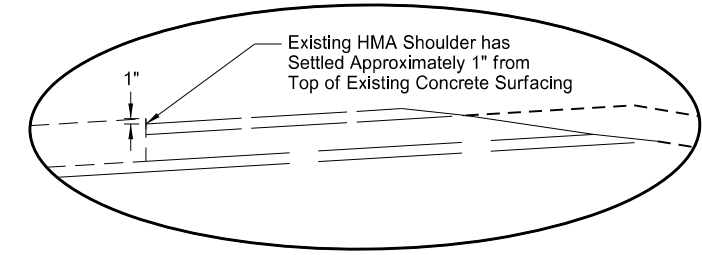

Inset D

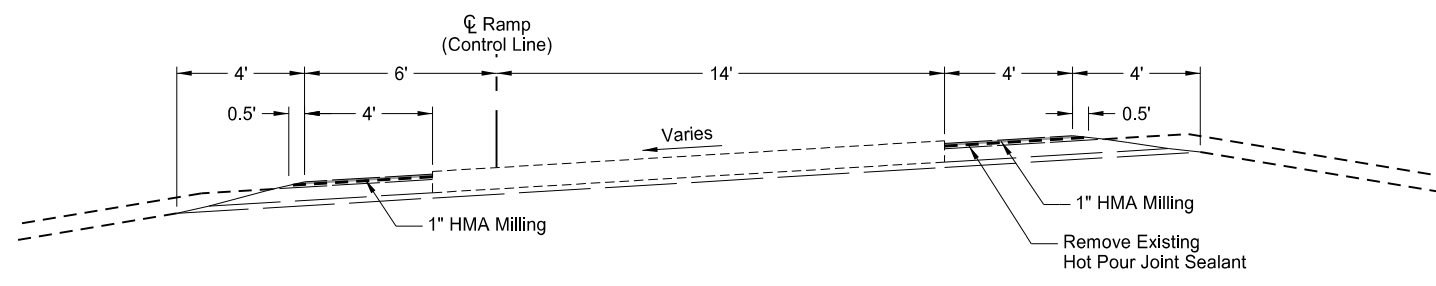

Removal Typical Section - Colfax & Walcott Interchange Southbound Ramps
 Sta 12+29 to Sta 22+23 (EXCOLSWR)
 Sta 1+13 to Sta 10+82 (EXCOLNWR)
 Sta 12+68 to Sta 21+61 (EX60SWR)
 Sta 0+92 to Sta 11+05 (EX60NWR)

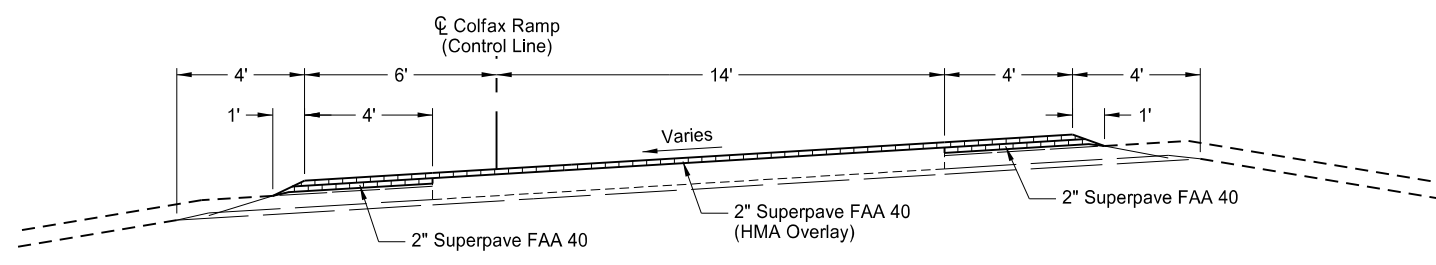

Proposed Typical Section - Colfax Interchange Southbound Ramps
 Sta 12+29 to Sta 22+23 (EXCOLSWR)
 Sta 1+13 to Sta 10+82 (EXCOLNWR)

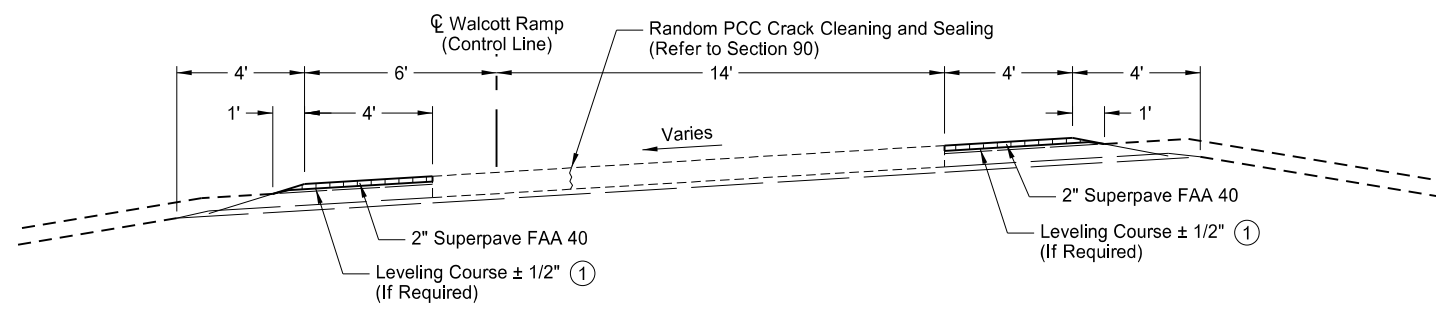

Proposed Typical Section - Walcott Interchange Southbound Ramps
 Sta 12+68 to Sta 21+61 (EX60SWR)
 Sta 0+92 to Sta 11+05 (EX60NWR)

- Notes:**
- ① Existing hot pour joint sealant will expand from HMA material during paving operations. If milling does not remove existing hot pour joint sealant, a leveling course will be required to insulate the sealant.

This document was originally issued and sealed by Jonathan D. Bach, Registration Number PE- 9797, on 08/07/17 and the original document is stored at the North Dakota Department of Transportation

I-29 - N of Galchutt Exit to Christine Exit
 Typical Sections
 Colfax Interchange Ramp Improvements
 Walcott Interchange Ramp Improvements

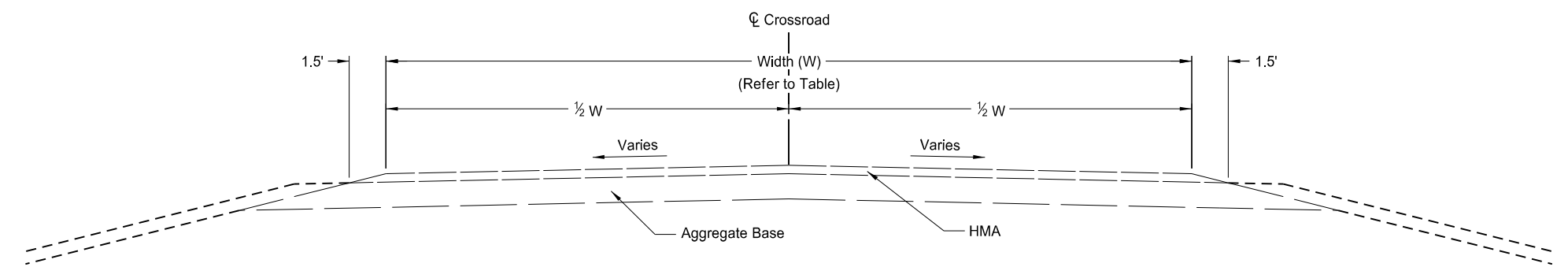

Existing Typical Section - Crossroad
 Sta 7+60 to Sta 13+83 (EXCOLFAX)
 Sta 17+60 to Sta 23+81 (EX60ST)
 Sta 10+62 to Sta 16+84 (EX58ST)
 Sta 19+19 to Sta 25+42 (EX58ST)

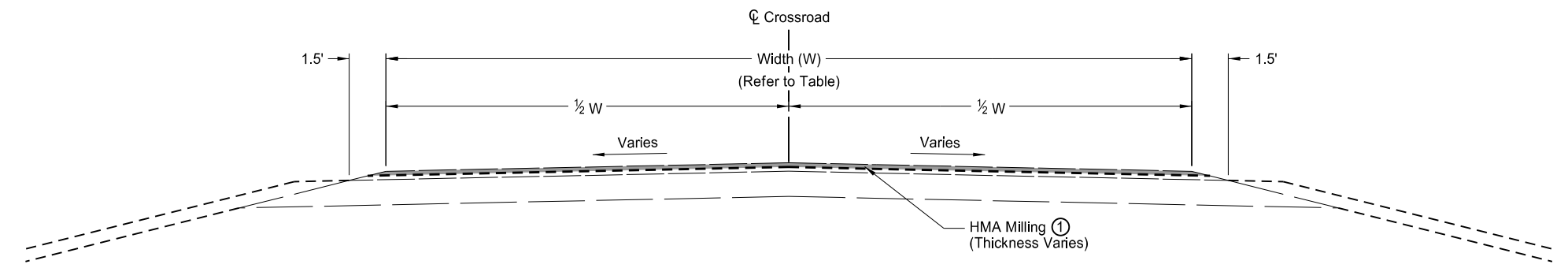

Removal Typical Section - Crossroad
 Sta 7+60 to Sta 8+60 (EXCOLFAX)
 Sta 11+30 to Sta 13+83 (EXCOLFAX)
 Sta 17+60 to Sta 23+81 (EX60ST)
 Sta 10+62 to Sta 16+64 (EX58ST)
 Sta 19+39 to Sta 25+42 (EX58ST)

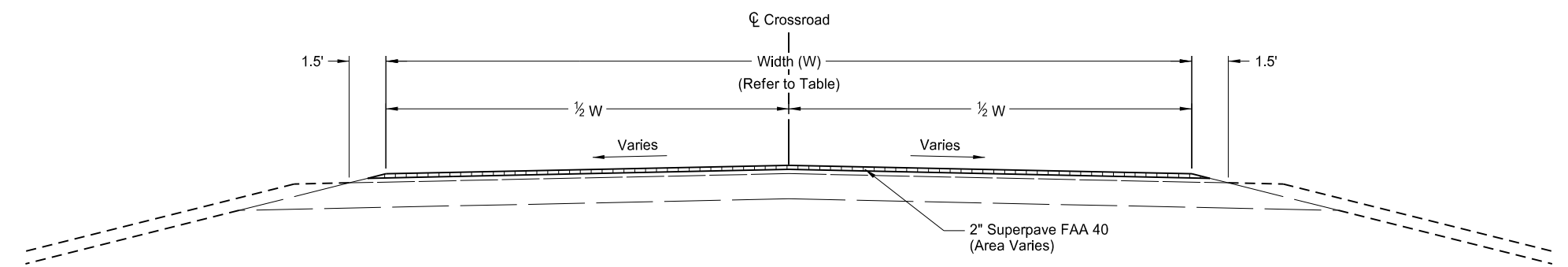

Proposed Typical Section - Crossroad
 Sta 7+60 to Sta 13+83 (EXCOLFAX)
 Sta 17+60 to Sta 23+81 (EX60ST)
 Sta 10+62 to Sta 16+64 (EX58ST)
 Sta 19+39 to Sta 25+42 (EX58ST)

Notes:
 ① Refer to Sections 20 and 40 for milling thicknesses and transitions.

This document was originally issued and sealed by Jonathan D. Bach, Registration Number PE- 9797, on 08/07/17 and the original document is stored at the North Dakota Department of Transportation

CROSSROAD WIDTHS				
Interchange	Overpass Roadway	Begin Station	End Station	Width (W) (ft)
Colfax (RP 37.043)	County Road 4 / Colfax Ave	7+60	8+91	32
		8+91	12+30	42
		12+30	13+83	32
Walcott (RP 42.169)	County Road 2 / 60th St SE	17+60	18+91	24
		18+91	22+03	38
		22+03	23+81	26
Christine (RP 44.126)	County Road 2N / 58th St SE	10+62	11+92	32
		11+92	16+64	38
		19+39	24+10	38
		24+10	25+42	32

I-29 - N of Galchutt Exit to Christine Exit
 Typical Sections
 Colfax Interchange Crossroad
 Walcott Interchange Crossroad
 Christine Interchange Crossroad

STATE	PROJECT NO.	SECTION NO.	SHEET NO.
ND	IM-8-029(170)033	30	6

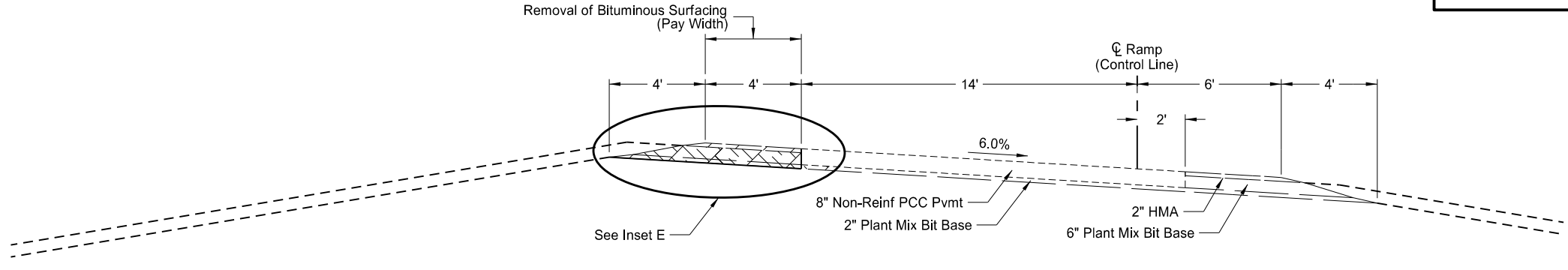

Removal Typical Section - Existing Northbound Ramps
 Sta 11+08 to Sta 13+11 (EXCOLSER)
 Sta 6+63 to Sta 8+48 (EXCOLNER)
 Sta 11+21 to Sta 13+23 (EX60SER)
 Sta 4+73 to Sta 6+81 (EX60NER)
 Sta 11+28 to Sta 13+39 (EX58SER)

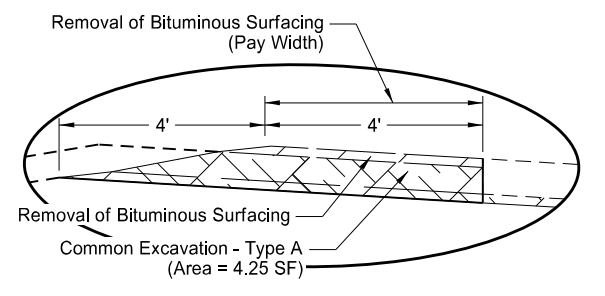

Inset E

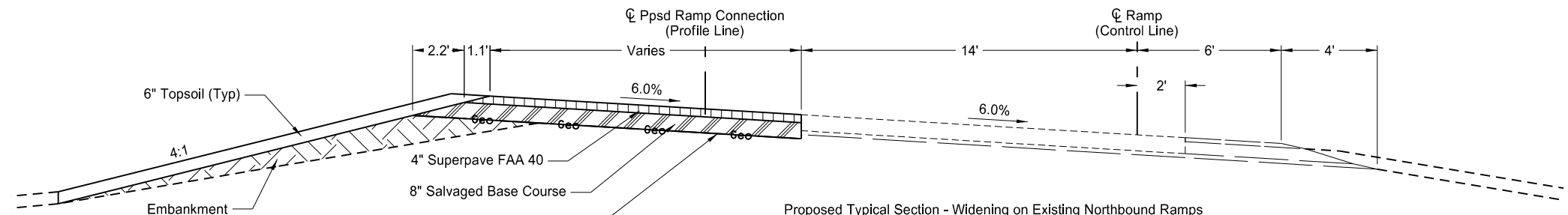

Proposed Typical Section - Widening on Existing Northbound Ramps
 Sta 113+72 to Sta 115+76 (RC_37_N_SER)
 Sta 201+36 to Sta 203+22 (RC_37_N_NER)
 Sta 313+83 to Sta 315+86 (RC_42_N_SER)
 Sta 401+27 to Sta 403+36 (RC_42_N_NER)
 Sta 513+93 to Sta 516+05 (RC_44_N_SER)

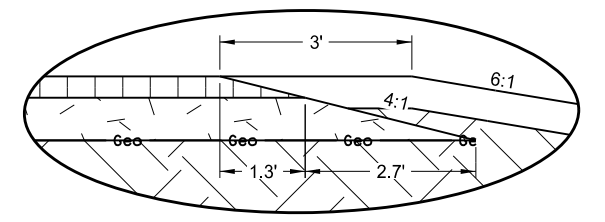

Inset F-1 (Within Median)

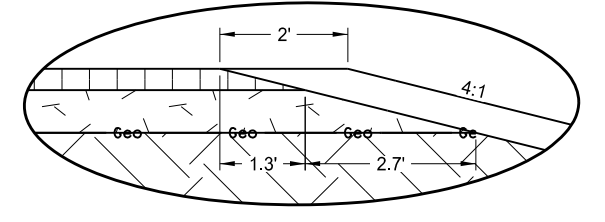

Inset F-2 (Outside Median)

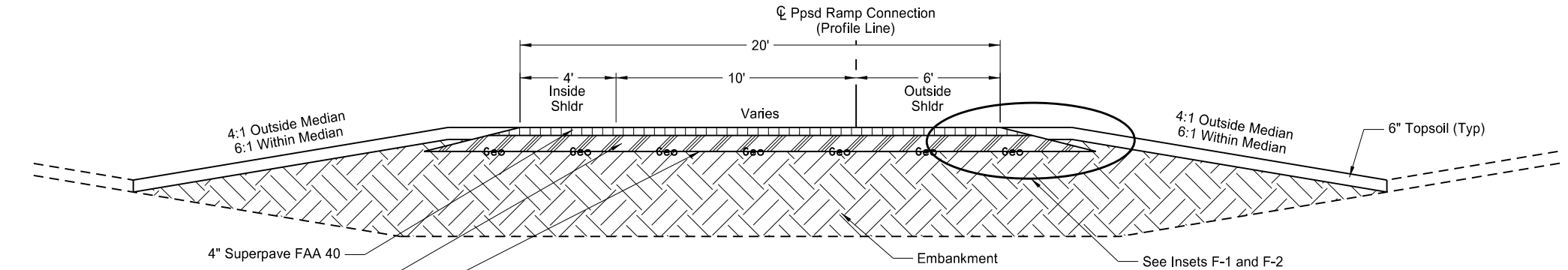

Proposed Typical Section - Ramp Connections
 Sta 108+39 to Sta 110+64 (RC_37_N_SER)
 Sta 112+67 to Sta 113+72 (RC_37_N_SER)
 Sta 203+22 to Sta 204+50 (RC_37_N_NER)
 Sta 206+59 to Sta 209+12 (RC_37_N_NER)
 Sta 308+39 to Sta 310+65 (RC_42_N_SER)
 Sta 312+68 to Sta 313+83 (RC_42_N_SER)
 Sta 403+36 to Sta 405+21 (RC_42_N_NER)
 Sta 407+16 to Sta 409+45 (RC_42_N_NER)
 Sta 508+39 to Sta 510+64 (RC_44_N_SER)
 Sta 512+68 to Sta 513+93 (RC_44_N_SER)

This document was originally issued and sealed by Jonathan D. Bach, Registration Number PE- 9797, on 08/07/17 and the original document is stored at the North Dakota Department of Transportation

I-29 - N of Galchutt Exit to Christine Exit
 Typical Sections
 Ramp Connections

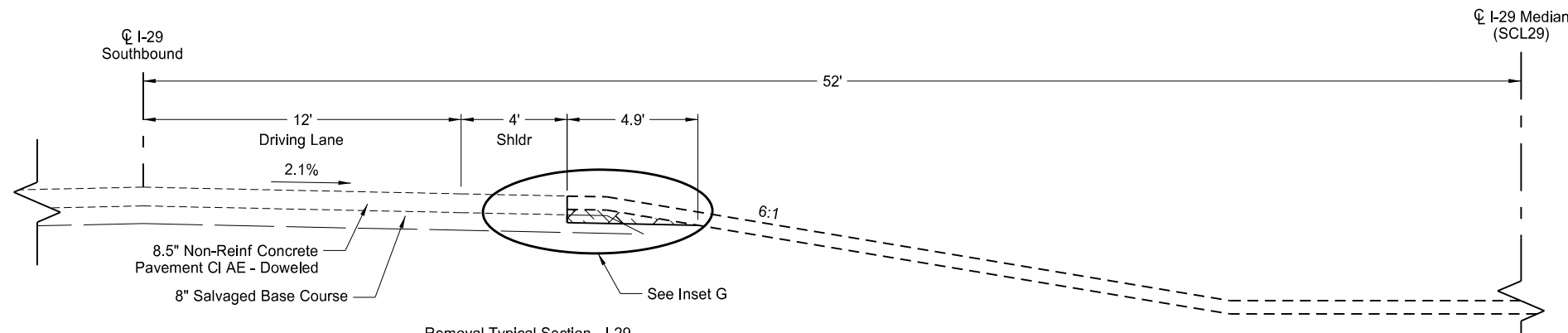

- Removal Typical Section - I-29**
- Sta 1934+77 to Sta 1943+18 Lt (SCL29)
 - Sta 1945+33 to Sta 1946+23 Rt (SCL29) ①
 - Sta 1946+67 to Sta 1947+36 Rt (SCL29) ①
 - Sta 1963+64 to Sta 1964+34 Rt (SCL29) ①
 - Sta 1964+80 to Sta 1965+72 Rt (SCL29) ①
 - Sta 1968+17 to Sta 1980+00 Lt (SCL29)
 - Sta 2204+48 to Sta 2212+89 Lt (SCL29)
 - Sta 2215+05 to Sta 2215+94 Rt (SCL29) ①
 - Sta 2216+39 to Sta 2217+08 Rt (SCL29) ①
 - Sta 2233+15 to Sta 2233+82 Rt (SCL29) ①
 - Sta 2234+24 to Sta 2235+09 Rt (SCL29) ①
 - Sta 2237+28 to Sta 2249+26 Lt (SCL29)
 - Sta 2309+86 to Sta 2318+27 Lt (SCL29)
 - Sta 2320+42 to Sta 2321+32 Rt (SCL29) ①
 - Sta 2321+76 to Sta 2322+46 Rt (SCL29) ①

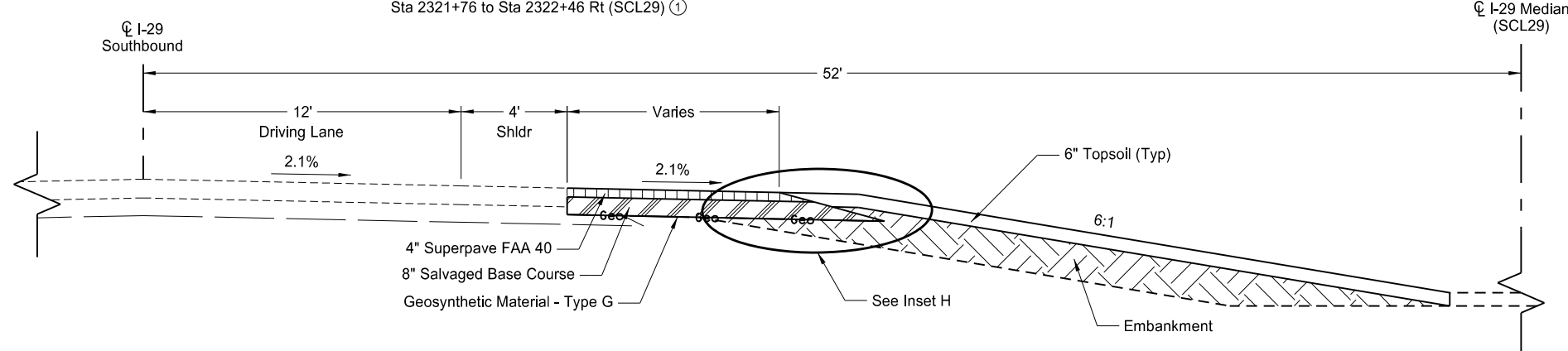
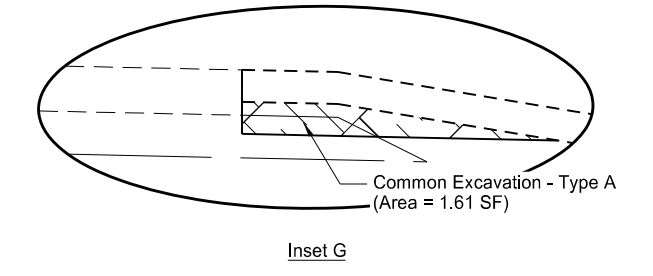

- Proposed Typical Section - Widening on I-29**
- Sta 100+00 to Sta 108+39 (RC_37_N_SER)
 - Sta 110+64 to Sta 111+49 (RC_37_N_SER) ①
 - Sta 112+04 to Sta 112+67 (RC_37_N_SER) ①
 - Sta 204+50 to Sta 205+15 (RC_37_N_NER) ①
 - Sta 205+71 to Sta 206+59 (RC_37_N_NER) ①
 - Sta 209+12 to Sta 220+94 (RC_37_N_NER)
 - Sta 300+00 to Sta 308+39 (RC_42_N_SER)
 - Sta 310+65 to Sta 311+50 (RC_42_N_SER) ①
 - Sta 312+04 to Sta 312+68 (RC_42_N_SER) ①
 - Sta 405+21 to Sta 405+83 (RC_42_N_NER) ①
 - Sta 406+35 to Sta 407+16 (RC_42_N_NER) ①
 - Sta 409+45 to Sta 421+34 (RC_42_N_NER)
 - Sta 500+00 to Sta 508+39 (RC_44_N_SER)
 - Sta 510+64 to Sta 511+50 (RC_44_N_SER) ①
 - Sta 512+04 to Sta 512+68 (RC_44_N_SER) ①

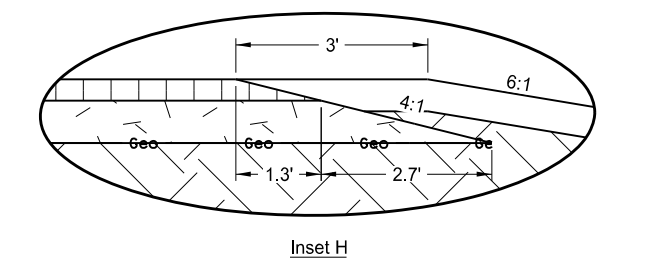

This document was originally issued and sealed by Jonathan D. Bach, Registration Number PE- 9797, on 08/07/17 and the original document is stored at the North Dakota Department of Transportation

Notes:
 ① Proposed ramp connection widening / removal is on I-29 Northbound. Refer to Section 60 and 200 for additional information.

I-29 - N of Galchutt Exit to Christine Exit
 Typical Sections
 Ramp Connections

STATE	PROJECT NO.	SECTION NO.	SHEET NO.
ND	IM-8-029(170)033	40	1

SPEC	CODE	BID ITEM	QTY	UNIT
202	0130	REMOVAL OF CURB & GUTTER		
		Sta 1796+79 - 117' Rt to Sta 1796+79 - 157' Rt	40	LF
		Sta 1796+81 - 158' Lt to Sta 1796+81 - 118' Lt	40	LF
		Sta 1797+10 - 117' Lt to Sta 1797+10 - 157' Lt	40	LF
		Sta 1797+12 - 158' Lt to Sta 1797+12 - 118' Lt	40	LF
202	0136	REMOVAL OF PAVEMENT		
		Sta 1764+76 to 1800+00 Lt (Mainline)	7,219	TON
		Sta 1764+76 to 1770+81 Lt (Median Crossover)	99	TON

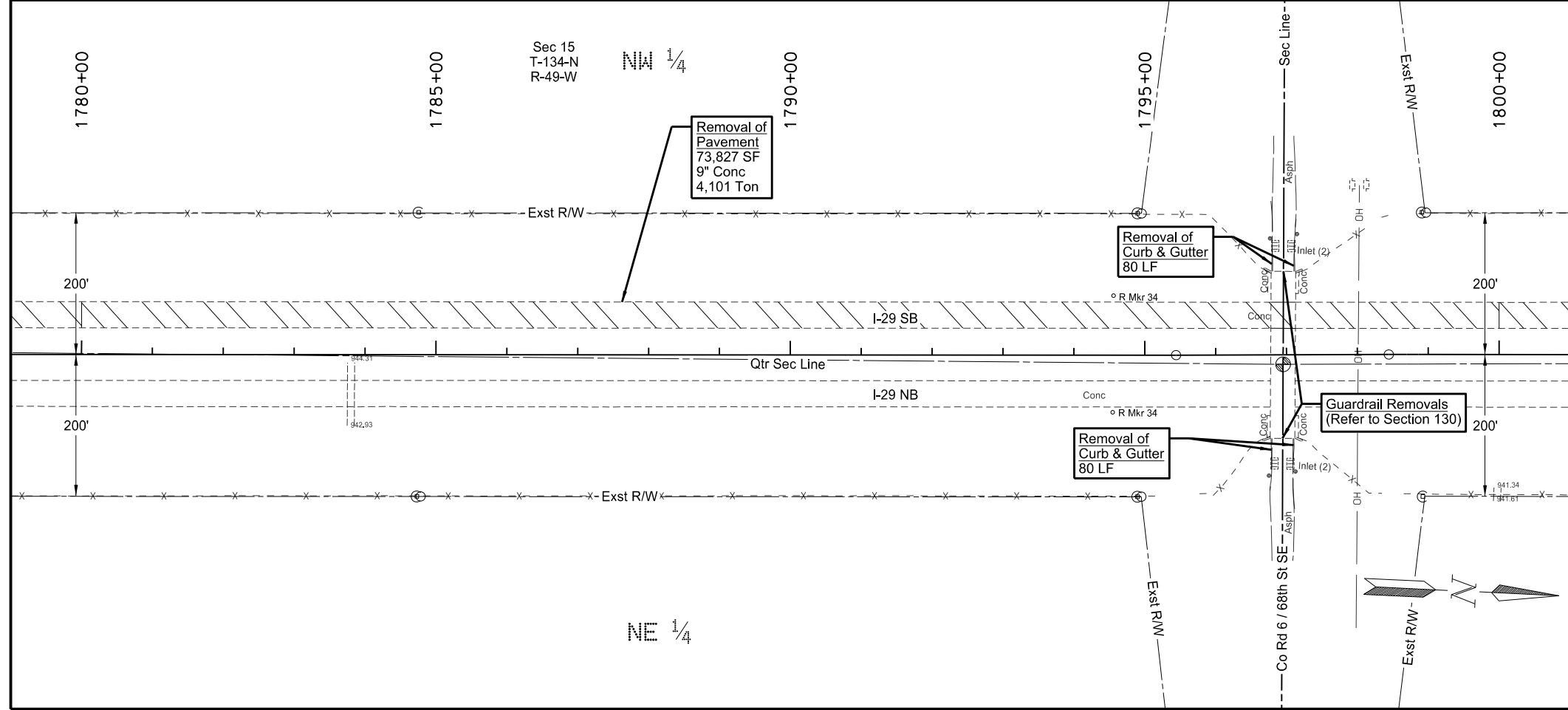
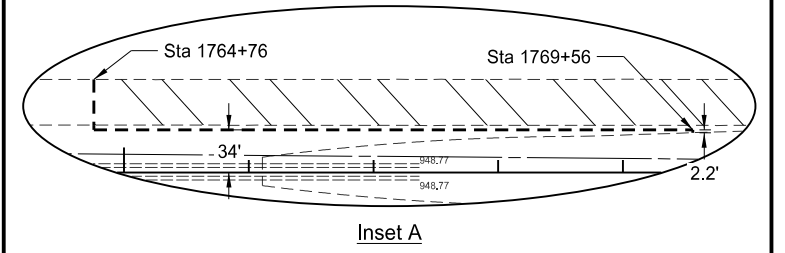
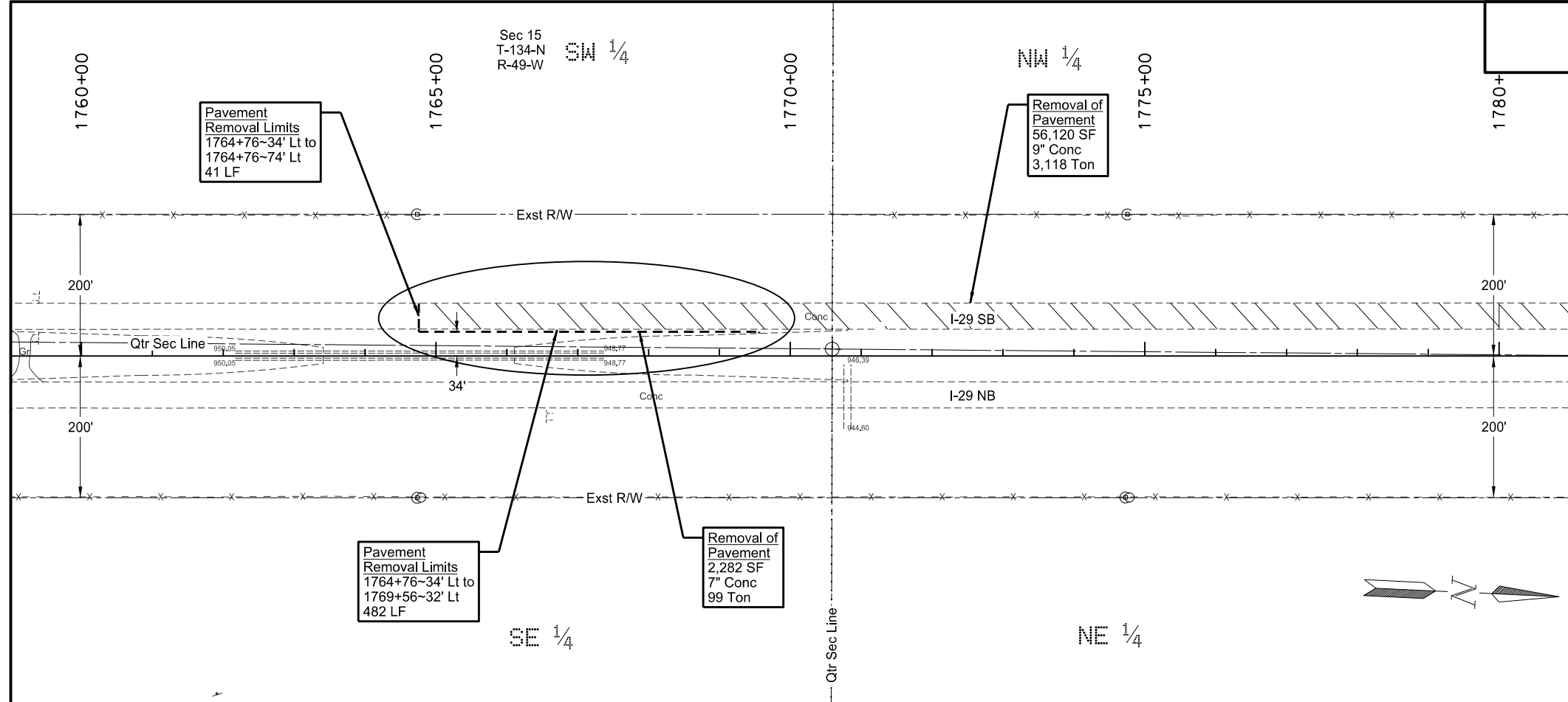

Notes:
1. Refer to Section 130 for guardrail removal quantities.

- Removal of Pavement (Concrete)
- Removal of Pavement (Asphalt & Concrete)
- Pavement Removal Limits

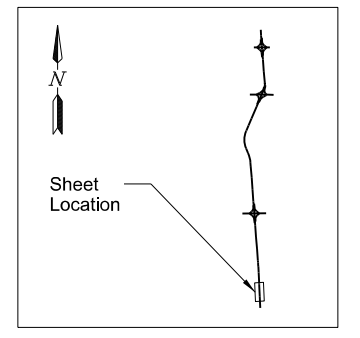

This document was originally issued and sealed by
Chad A. Petersen,
Registration Number
PE- 4884,
on 08/07/17 and the original document is stored at the
North Dakota Department
of Transportation

I-29 - N of Galchutt Exit to Christine Exit
Removals - Phase 3
Interstate 29
Sta 1764+76 to 1800+00 (SCL29)

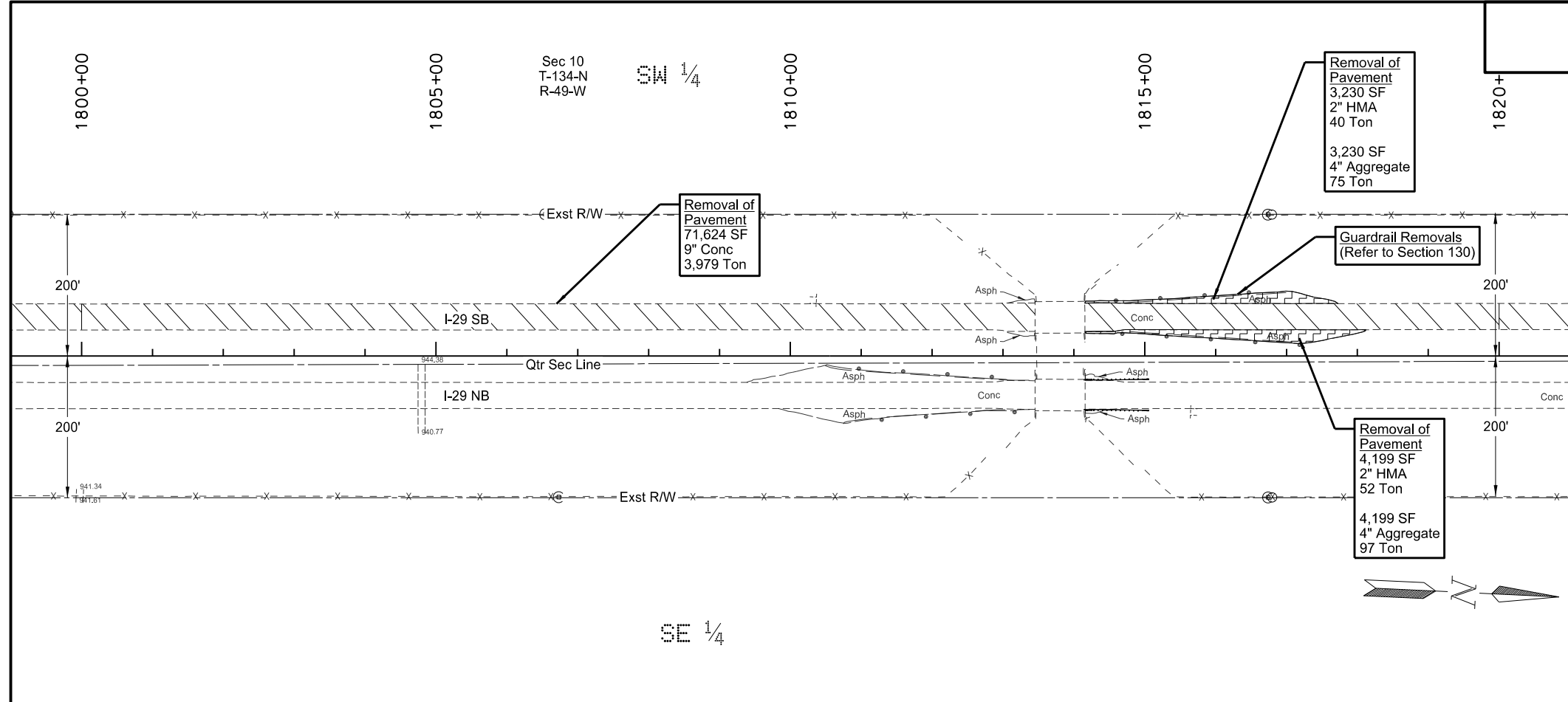

STATE	PROJECT NO.	SECTION NO.	SHEET NO.
ND	IM-8-029(170)033	40	2

SPEC	CODE	BID ITEM	QTY	UNIT
202	0136	REMOVAL OF PAVEMENT		
		Sta 1800+00 to 1840+00 Lt (Mainline)	8,077	TON
		Sta 1814+16 to 1817+73 Lt (Guardrail Grading)	115	TON
		Sta 1814+16 to 1818+12 Lt Mdn (Guardrail Grading)	149	TON

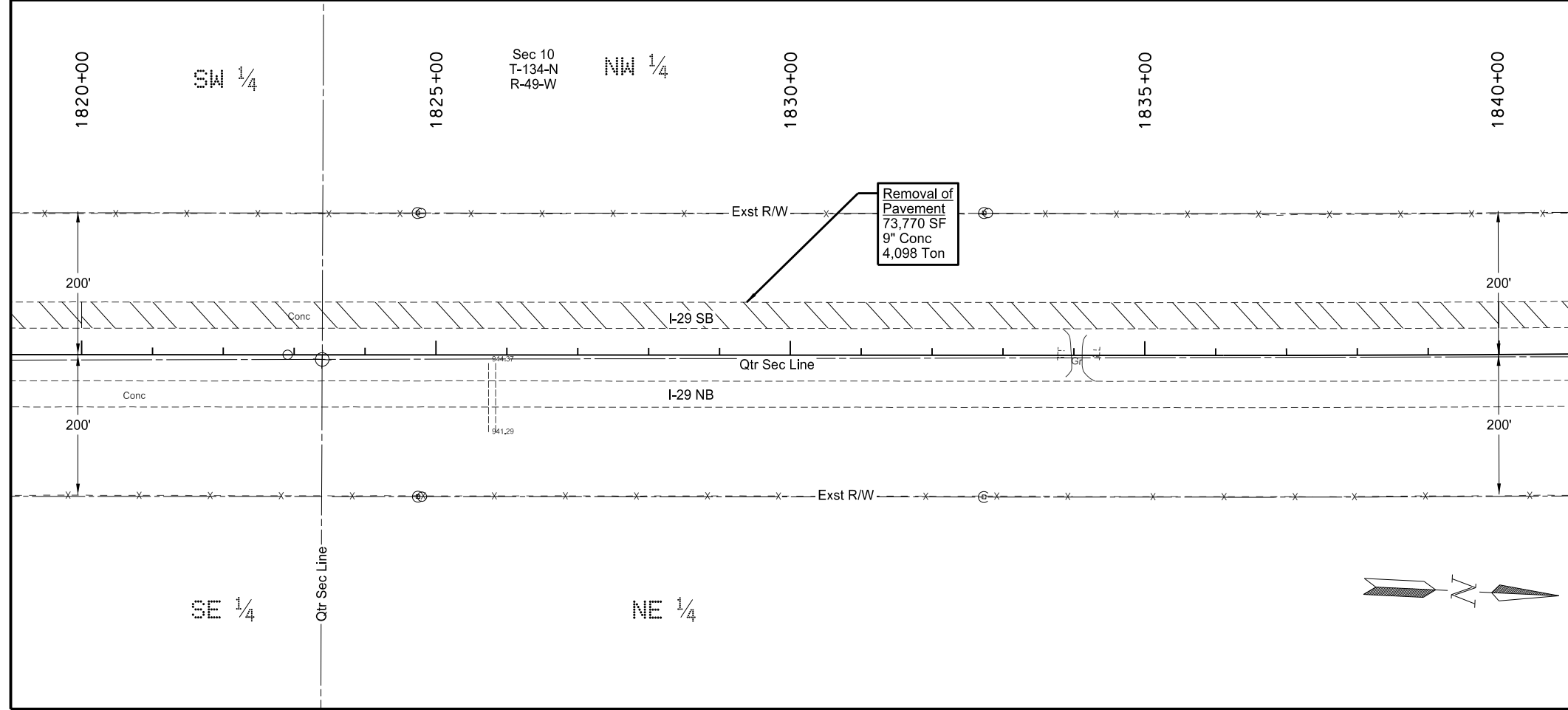

Notes:
1. Refer to Section 130 for guardrail removal quantities.

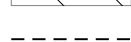

-  Removal of Pavement (Guardrail Grading)
-  Removal of Pavement (Concrete)
-  Removal of Pavement (Asphalt & Concrete)
-  Pavement Removal Limits

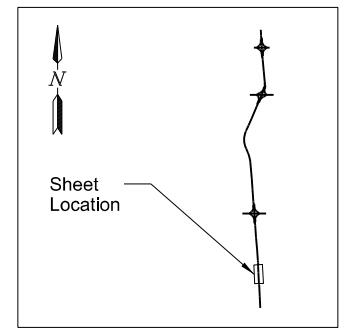

This document was originally issued and sealed by
Chad A. Petersen,
Registration Number
PE- 4884,
on 08/07/17 and the original document is stored at the
North Dakota Department
of Transportation

I-29 - N of Galchutt Exit to Christine Exit
Removals - Phase 3
Interstate 29
Sta 1800+00 to 1840+00 (SCL29)

STATE	PROJECT NO.	SECTION NO.	SHEET NO.
ND	IM-8-029(170)033	40	3

SPEC	CODE	BID ITEM	QTY	UNIT
202	0136	REMOVAL OF PAVEMENT Sta 1840+00 to 1880+00 Lt (Mainline)	8,199	TON
202	0169	REMOVAL OF END SECTION-ALL TYPES & SIZES Sta 1849+74 - 10' Lt	1	EA
		Sta 1849+76 - 96' Lt	1	EA

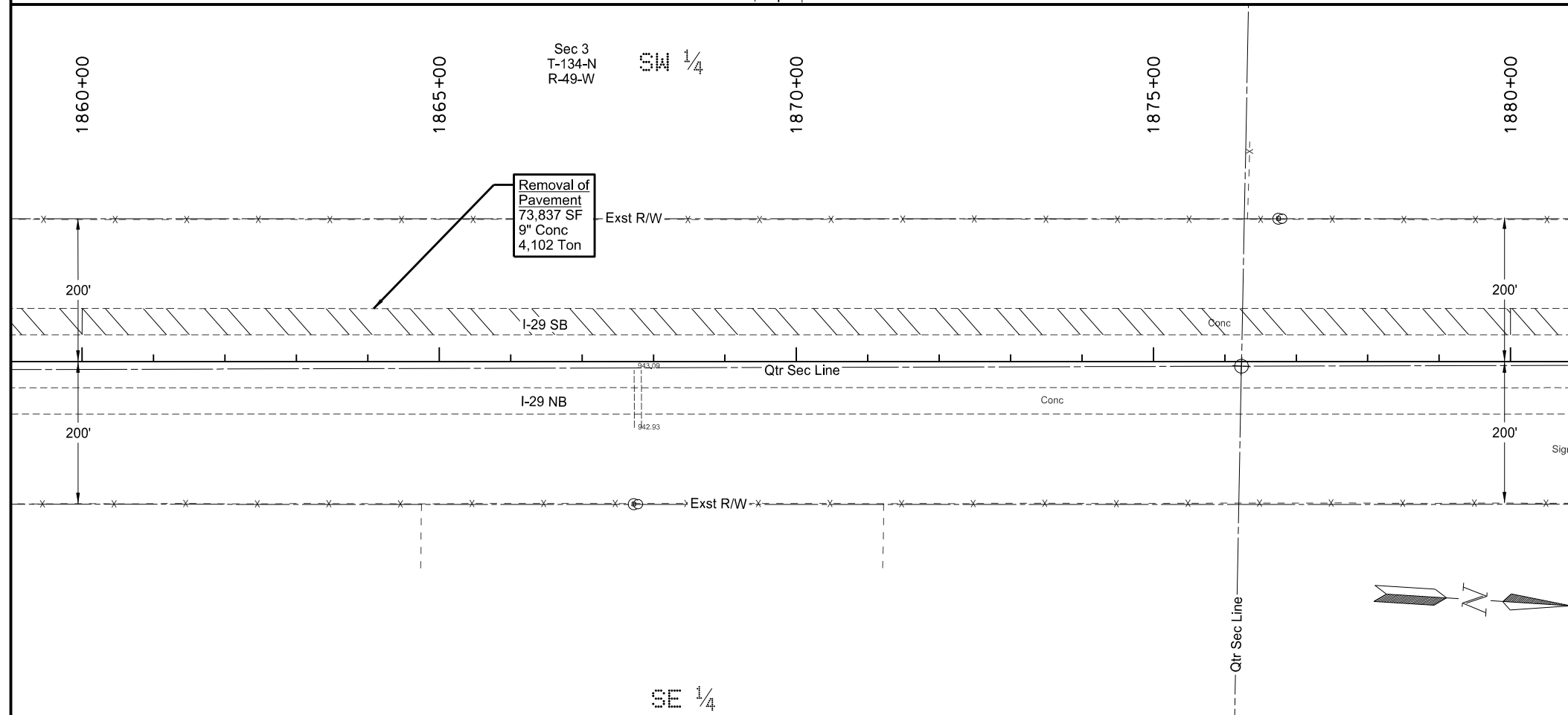
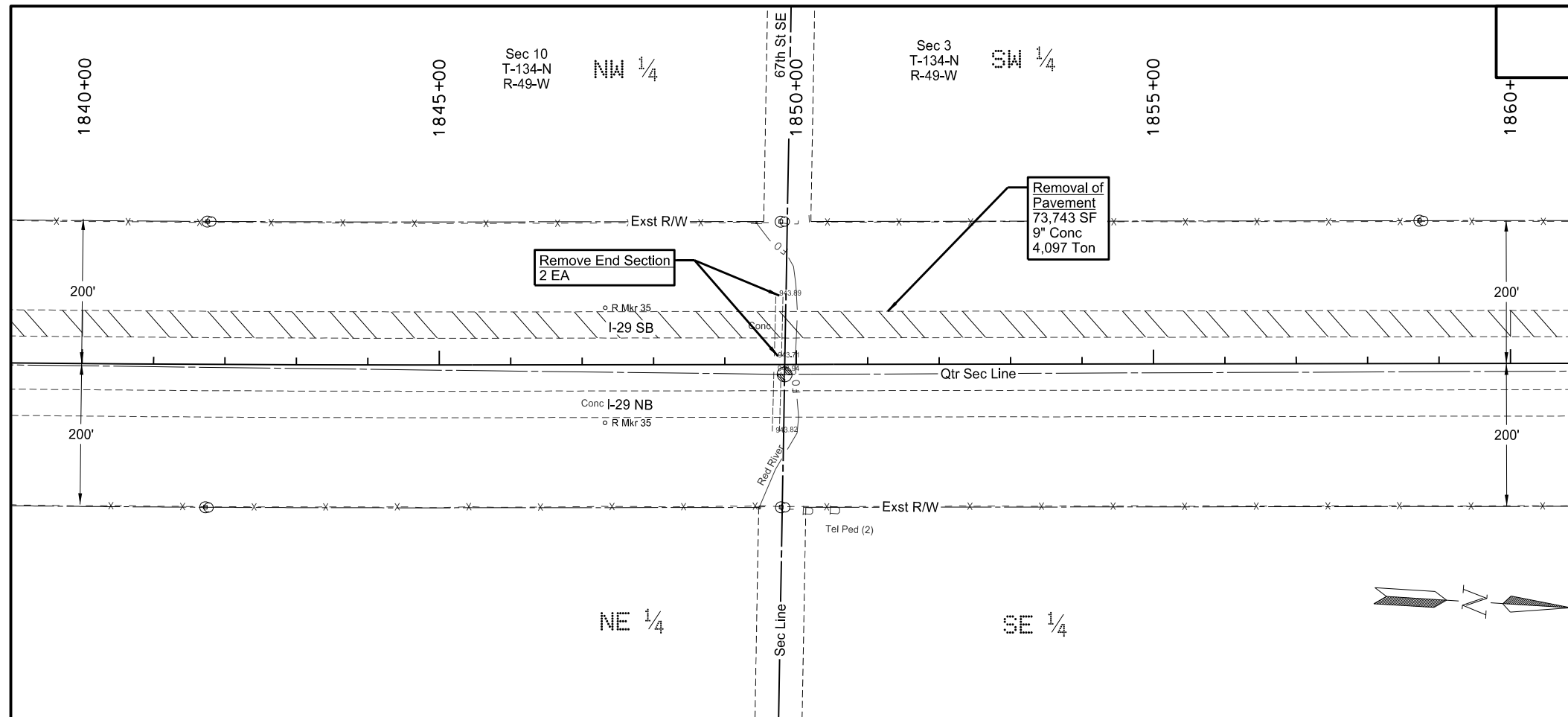

- Removal of Pavement (Concrete)
- Removal of Pavement (Asphalt & Concrete)
- Pavement Removal Limits

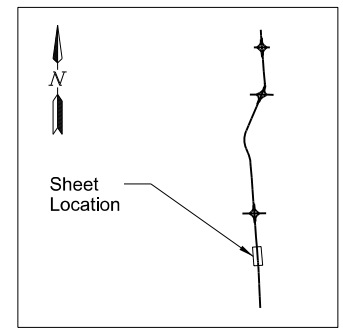



This document was originally issued and sealed by
 Chad A. Petersen,
 Registration Number
 PE- 4884,
 on 08/07/17 and the original document is stored at the
 North Dakota Department
 of Transportation

I-29 - N of Galchutt Exit to Christine Exit
 Removals - Phase 3
 Interstate 29
 Sta 1840+00 to 1880+00 (SCL29)

STATE	PROJECT NO.	SECTION NO.	SHEET NO.
ND	IM-8-029(170)033	40	4

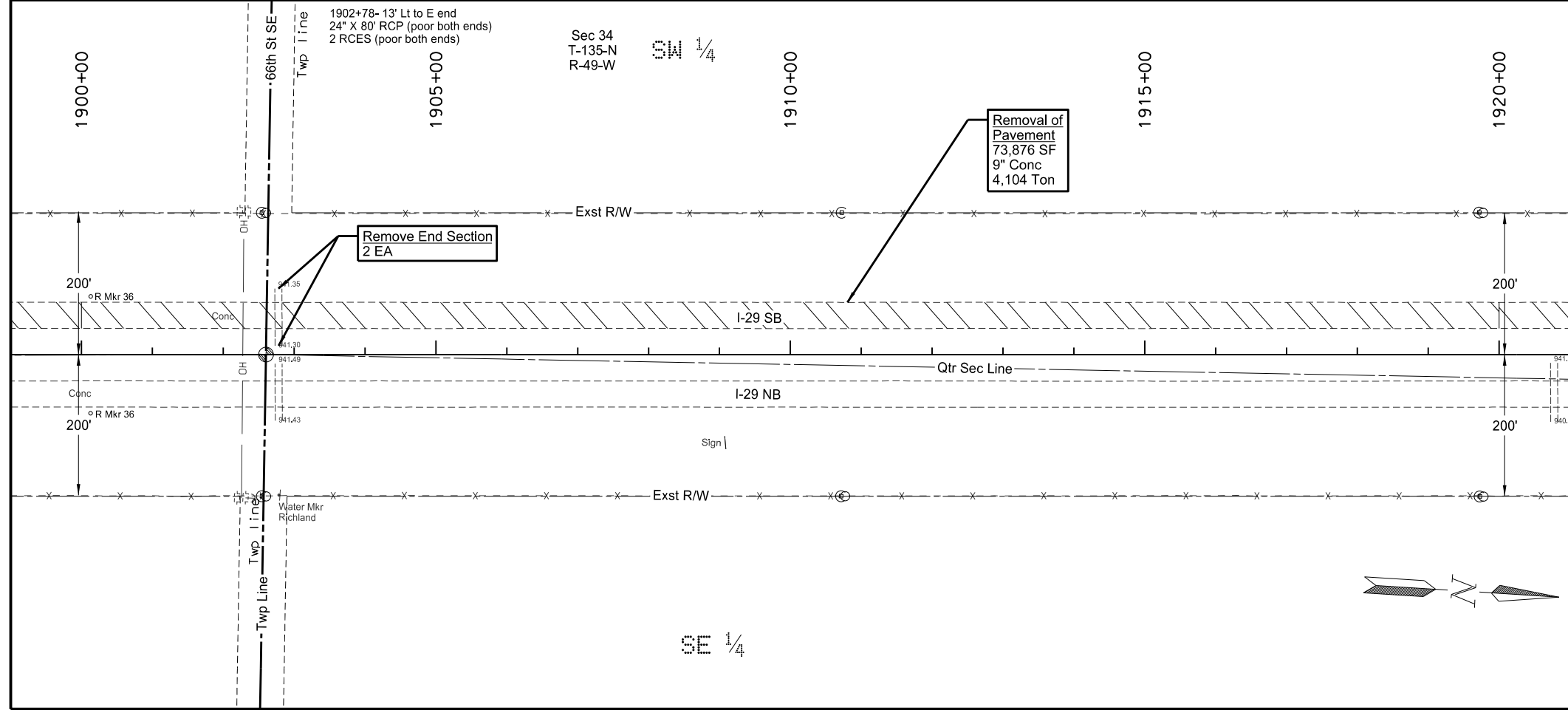
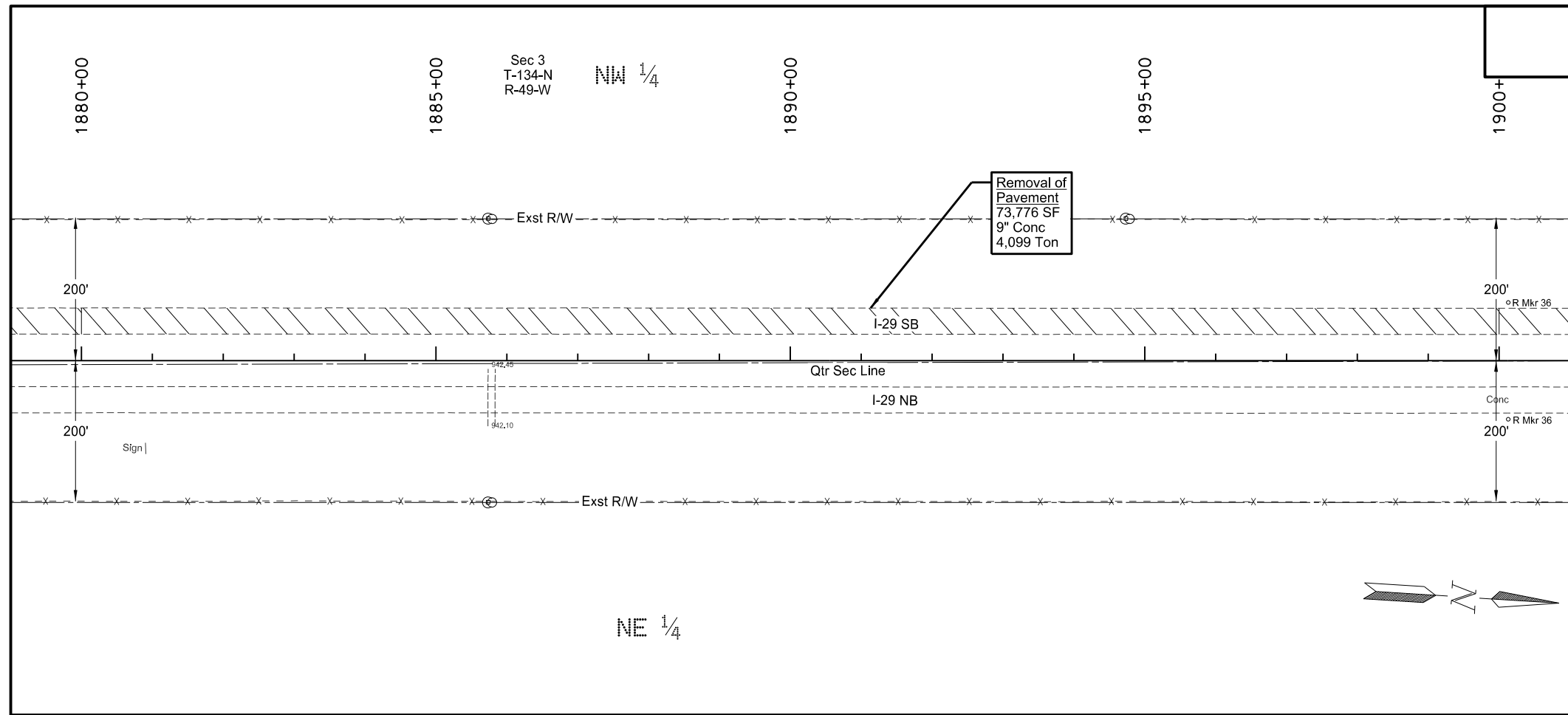
SPEC	CODE	BID ITEM	QTY	UNIT
202	0136	REMOVAL OF PAVEMENT		
Sta 1880+00 to 1920+00 Lt (Mainline)			8,203	TON
202	0169	REMOVAL OF END SECTION-ALL TYPES & SIZES		
Sta 1902+78 - 10' Lt			1	EA
Sta 1902+78 - 96' Lt			1	EA

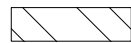
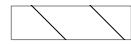

-  Removal of Pavement (Concrete)
-  Removal of Pavement (Asphalt & Concrete)
-  Pavement Removal Limits

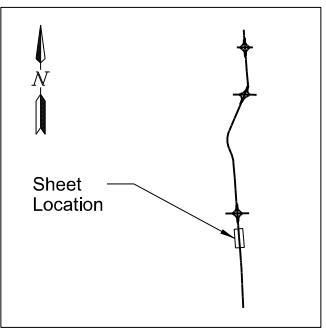

This document was originally issued and sealed by
 Chad A. Petersen,
 Registration Number
 PE- 4884,
 on 08/07/17 and the original document is stored at the
 North Dakota Department
 of Transportation

I-29 - N of Galchutt Exit to Christine Exit
 Removals - Phase 3
 Interstate 29
 Sta 1880+00 to 1920+00 (SCL29)

STATE	PROJECT NO.	SECTION NO.	SHEET NO.
ND	IM-8-029(170)033	40	5

SPEC	CODE	BID ITEM	QTY	UNIT
202	0136	REMOVAL OF PAVEMENT		
		Sta 1920+00 to 1960+00 Lt (Mainline)	8,210	TON
		Sta 1936+36 to 1945+91 Lt (Ramp Taper)	646	TON
202	0169	REMOVAL OF END SECTION-ALL TYPES & SIZES		
		Sta 1950+72 - 97' Lt	1	EA
		Sta 1950+84 - 97' Lt	1	EA

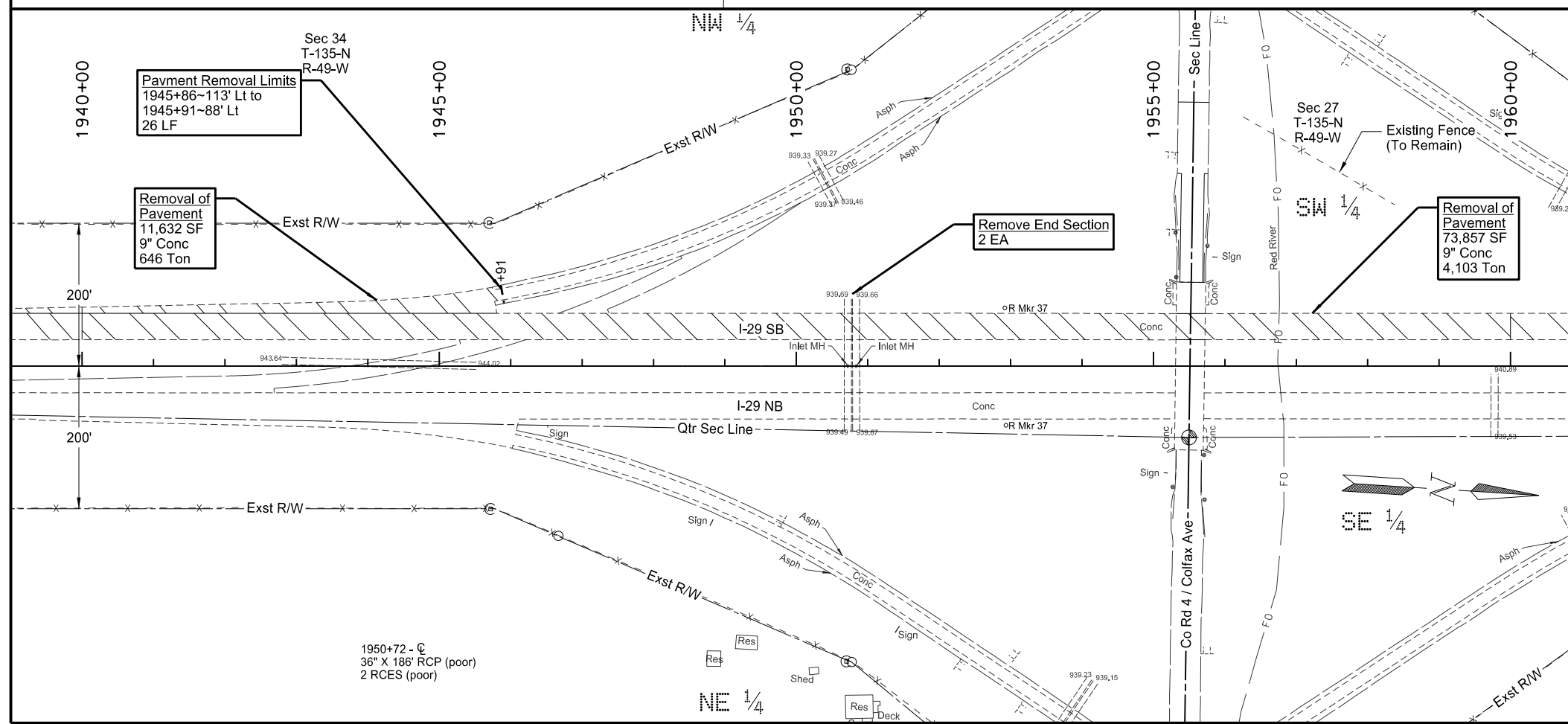
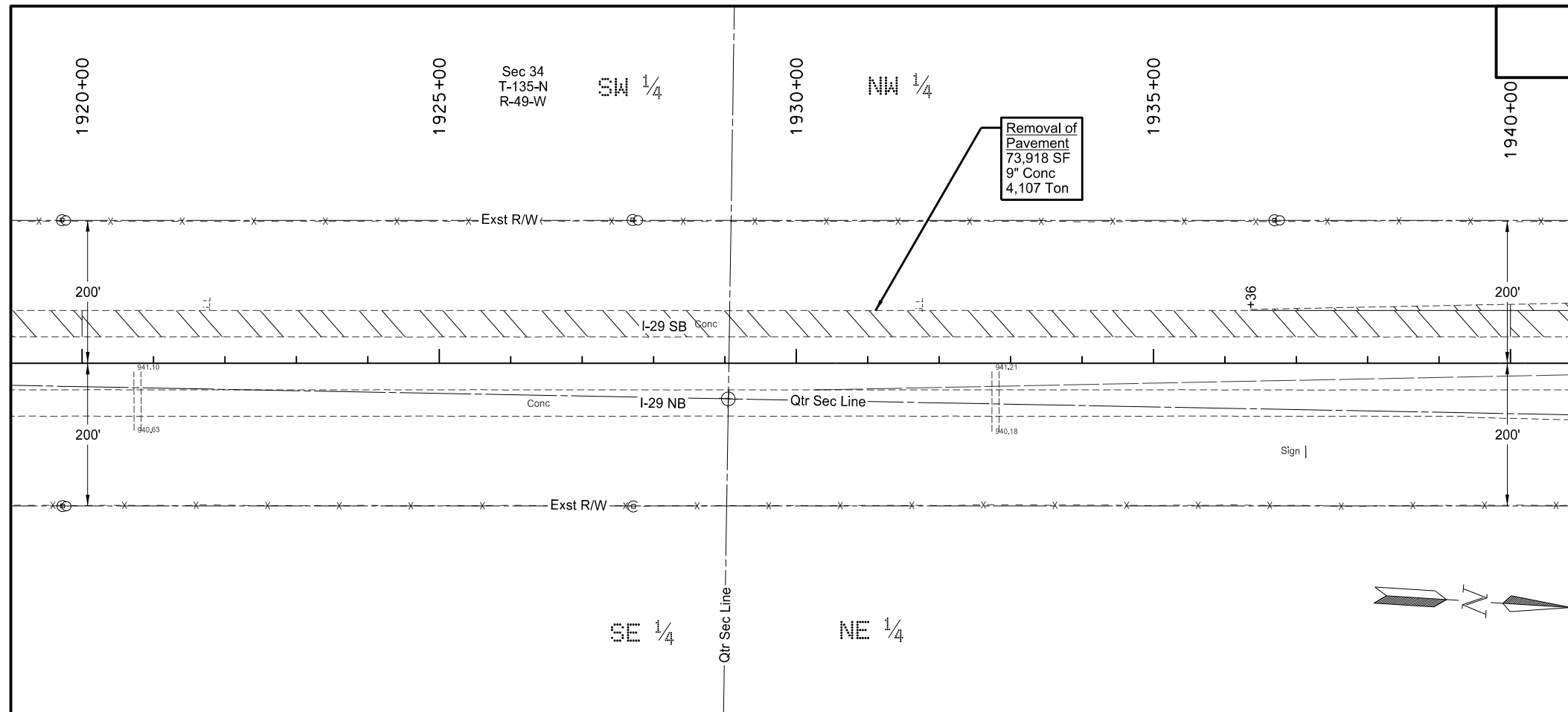

- Removal of Pavement (Concrete)
- Removal of Pavement (Asphalt & Concrete)
- Pavement Removal Limits

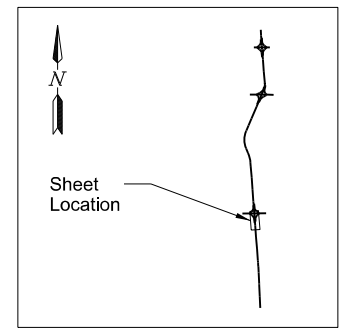



This document was originally issued and sealed by
 Chad A. Petersen,
 Registration Number
 PE- 4884,
 on 08/07/17 and the original document is stored at the
 North Dakota Department
 of Transportation

I-29 - N of Galchutt Exit to Christine Exit
 Removals - Phase 3
 Interstate 29
 Sta 1920+00 to 1960+00 (SCL29)

STATE	PROJECT NO.	SECTION NO.	SHEET NO.
ND	IM-8-029(170)033	40	6

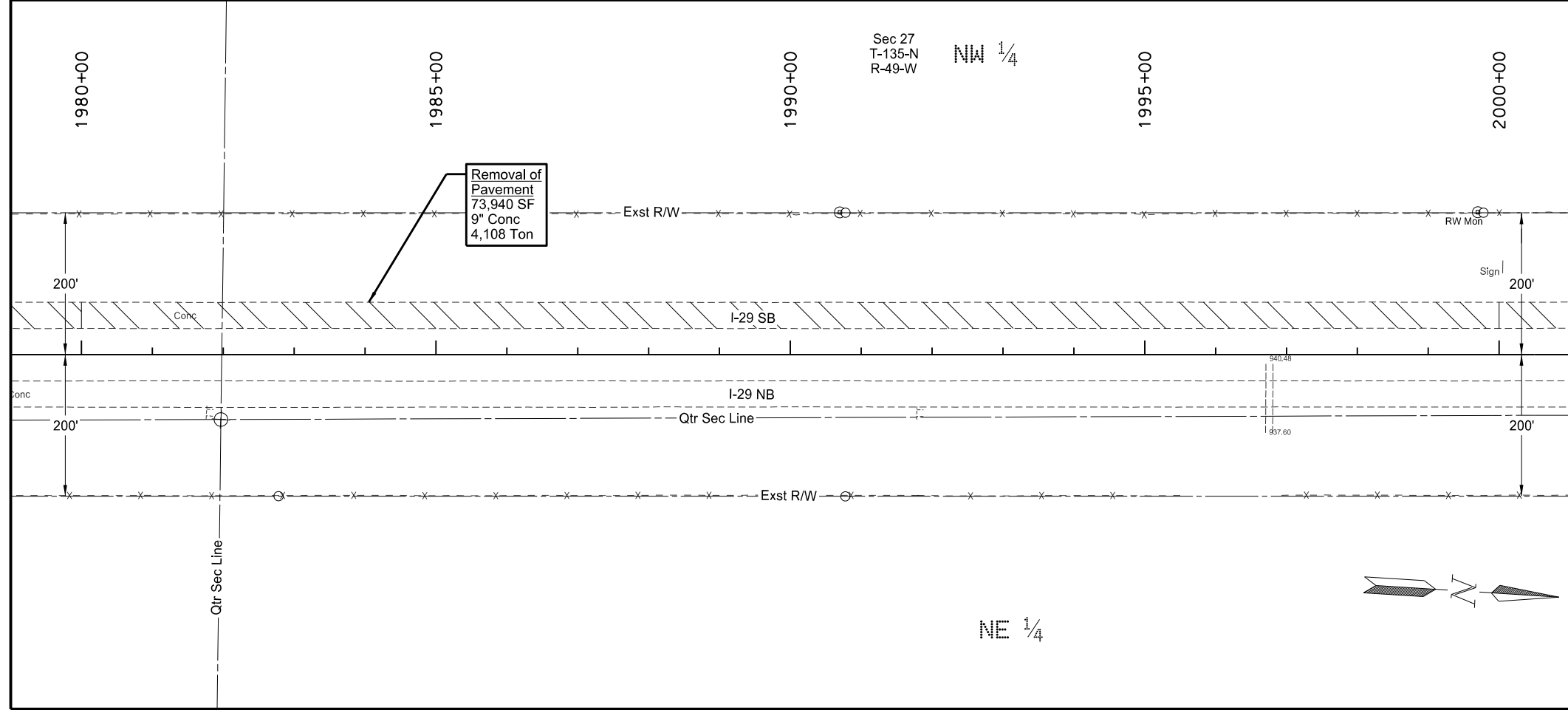
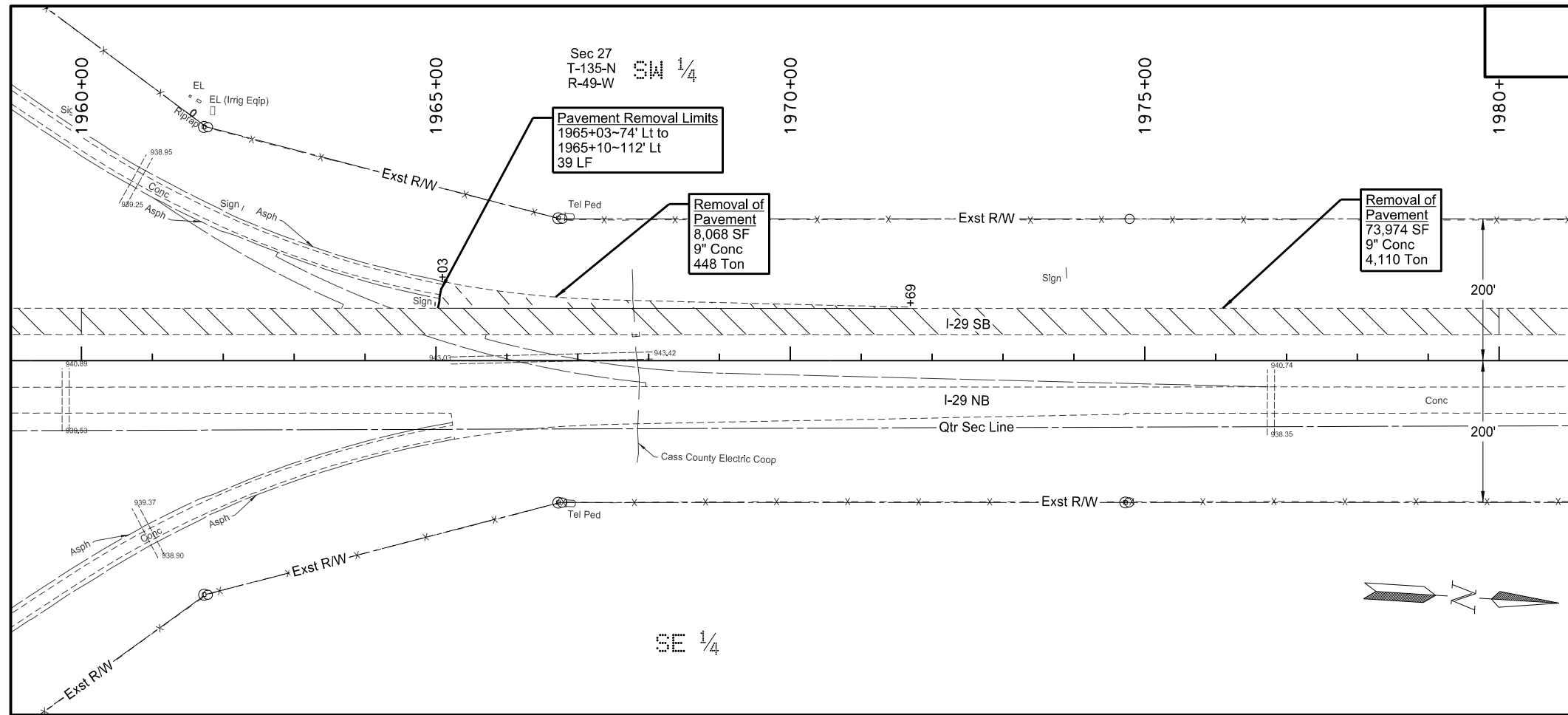
SPEC	CODE	BID ITEM	QTY	UNIT
202	0136	REMOVAL OF PAVEMENT		
		Sta 1960+00 to 2000+00 Lt (Mainline)	8,218	TON
		Sta 1965+03 to 1971+69 Lt (Ramp Taper)	448	TON

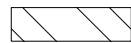
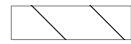

-  Removal of Pavement (Concrete)
-  Removal of Pavement (Asphalt & Concrete)
-  Pavement Removal Limits

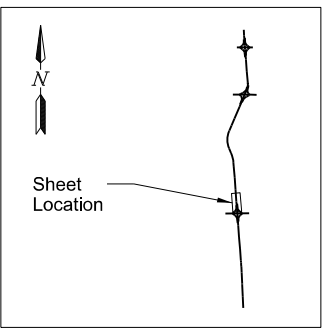

This document was originally issued and sealed by
 Chad A. Petersen,
 Registration Number
 PE- 4884,
 on 08/07/17 and the original document is stored at the
 North Dakota Department
 of Transportation

I-29 - N of Galchutt Exit to Christine Exit
 Removals - Phase 3
 Interstate 29
 Sta 1960+00 to 2000+00 (SCL29)

STATE	PROJECT NO.	SECTION NO.	SHEET NO.
ND	IM-8-029(170)033	40	7

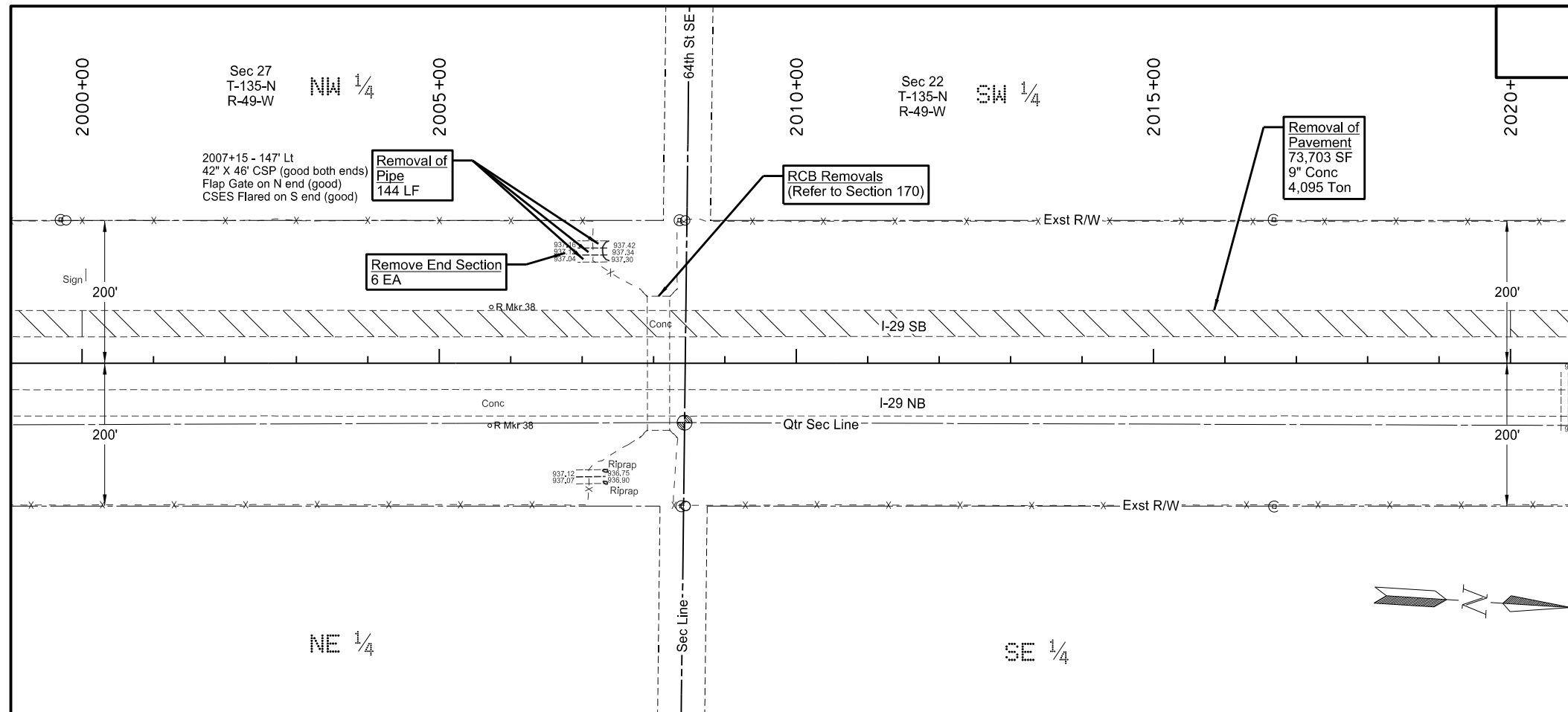

SPEC	CODE	BID ITEM	QTY	UNIT
202	0136	REMOVAL OF PAVEMENT Sta 2000+00 to 2040+00 Lt (Mainline)	8,200	TON
202	0169	REMOVAL OF END SECTION-ALL TYPES & SIZES		
		Sta 2006+91 - 166' Lt	1	EA
		Sta 2006+91 - 156' Lt	1	EA
		Sta 2006+91 - 146' Lt	1	EA
		Sta 2007+35 - 166' Lt	1	EA
		Sta 2007+35 - 157' Lt	1	EA
		Sta 2007+35 - 147' Lt	1	EA
202	0174	REMOVAL OF PIPE ALL TYPES AND SIZES		
		Sta 2006+91 - 166' Lt to Sta 2007+35 - 166' Lt	48	LF
		Sta 2006+91 - 156' Lt to Sta 2007+35 - 157' Lt	48	LF
		Sta 2006+91 - 146' Lt to Sta 2007+35 - 147' Lt	48	LF

Notes:
1. Refer to Section 170 for RCB extension removal quantities.

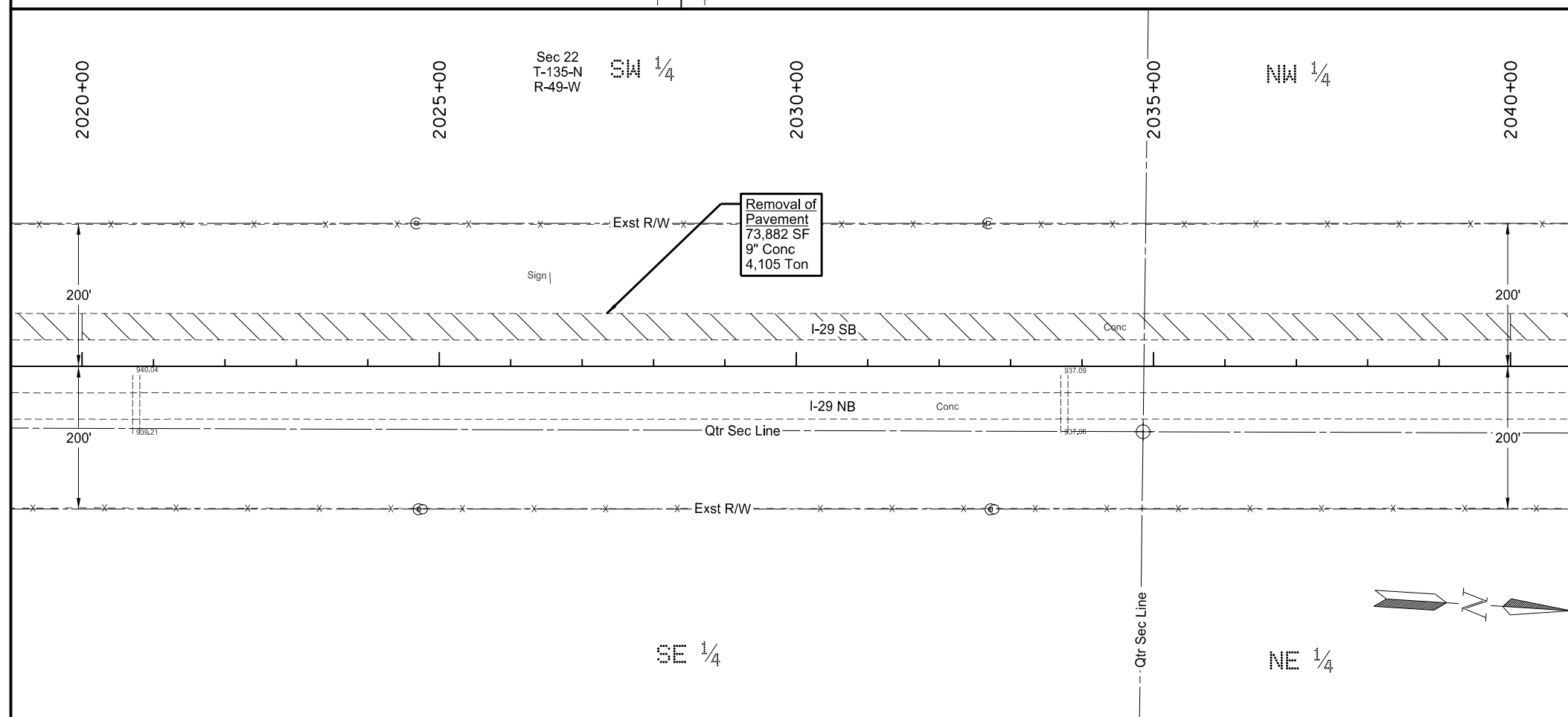

- Removal of Pavement (Concrete)
- Removal of Pavement (Asphalt & Concrete)
- Pavement Removal Limits

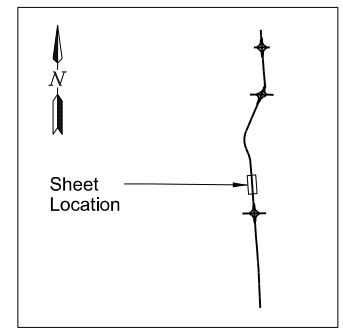

This document was originally issued and sealed by
Chad A. Petersen,
Registration Number
PE- 4884,
on 08/07/17 and the original document is stored at the
North Dakota Department
of Transportation

I-29 - N of Galchutt Exit to Christine Exit
Removals - Phase 3
Interstate 29
Sta 2000+00 to 2040+00 (SCL29)

STATE	PROJECT NO.	SECTION NO.	SHEET NO.
ND	IM-8-029(170)033	40	8

SPEC	CODE	BID ITEM	QTY	UNIT
202	0130	REMOVAL OF CURB & GUTTER		
		Sta 2061+12 - 117' Rt to Sta 2061+11 - 157' Rt	40	LF
		Sta 2061+15 - 158' Lt to Sta 2061+15 - 118' Lt	40	LF
		Sta 2061+43 - 118' Rt to Sta 2061+42 - 158' Rt	40	LF
		Sta 2061+46 - 157' Lt to Sta 2061+46 - 117' Lt	40	LF
202	0136	REMOVAL OF PAVEMENT		
		Sta 2040+00 to 2080+00 Lt (Mainline)	9,697	TON
202	0169	REMOVAL OF END SECTION-ALL TYPES & SIZES		
		Sta 2058+76 - 10' Lt	1	EA
		Sta 2058+76 - 94' Lt	1	EA

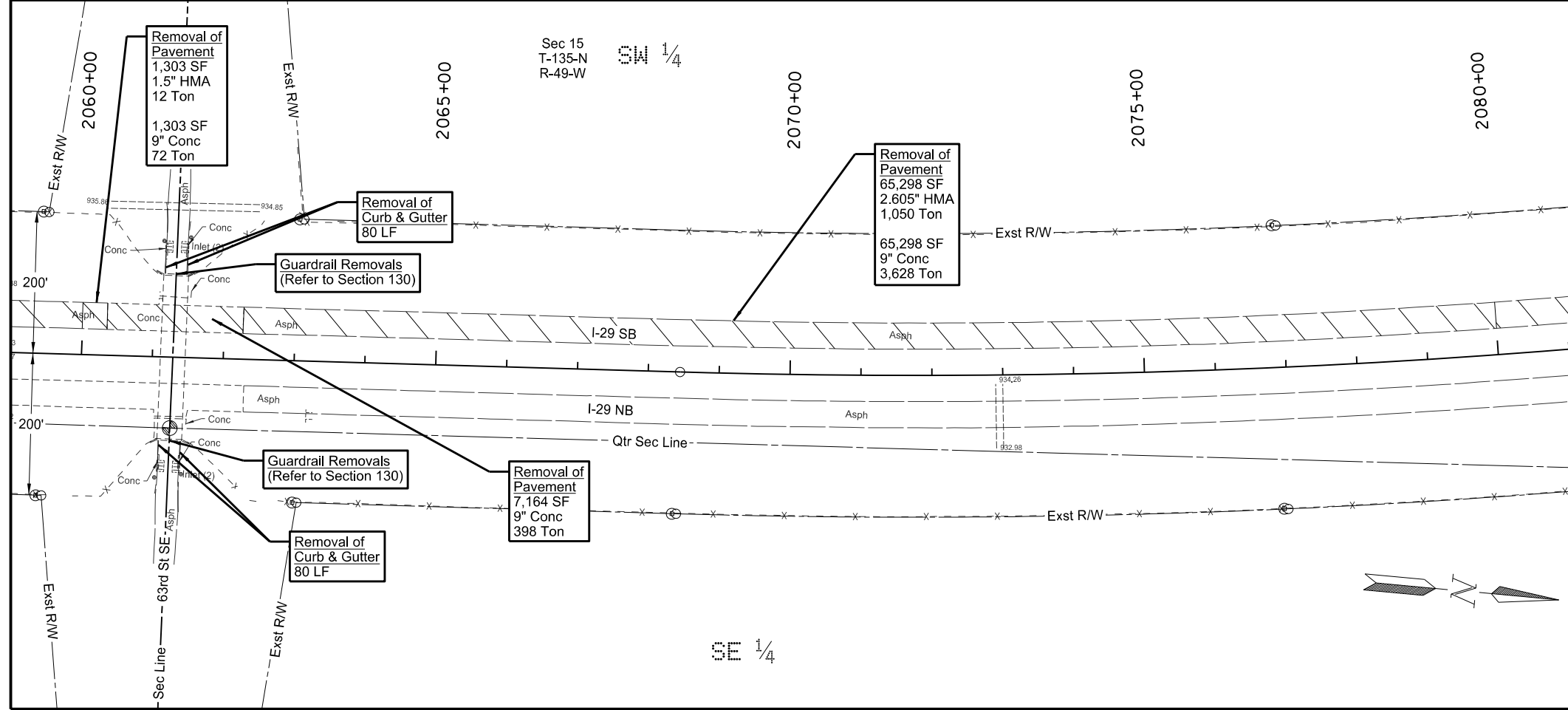
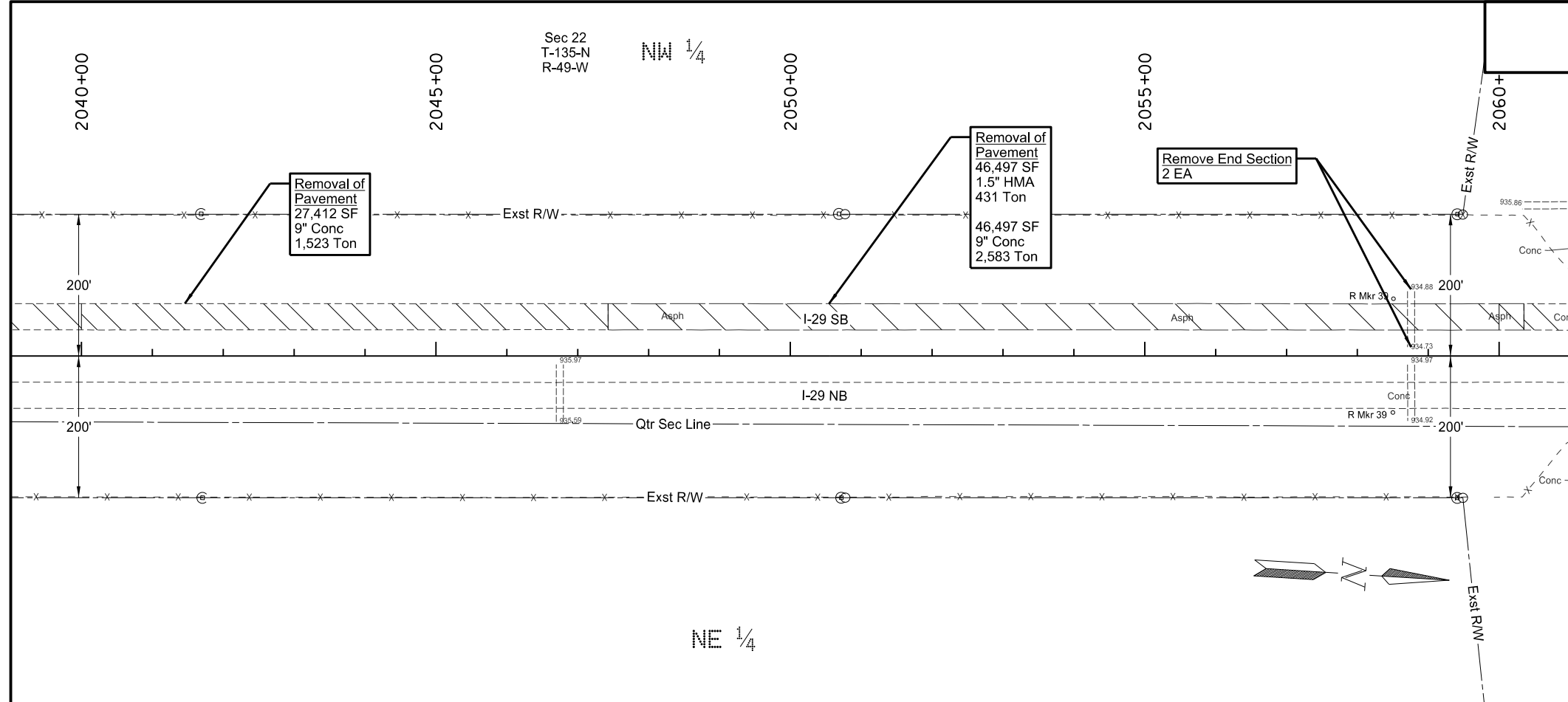

Notes:
1. Refer to Section 130 for guardrail removal quantities.

- Removal of Pavement (Concrete)
- Removal of Pavement (Asphalt & Concrete)
- Pavement Removal Limits

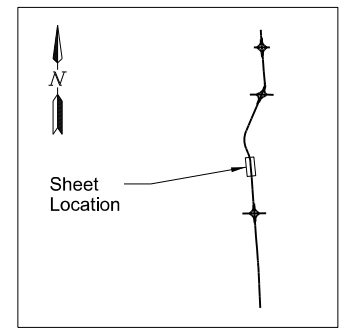

This document was originally issued and sealed by
Chad A. Petersen,
Registration Number
PE- 4884,
on 08/07/17 and the original document is stored at the
North Dakota Department
of Transportation

I-29 - N of Galchutt Exit to Christine Exit
Removals - Phase 3
Interstate 29
Sta 2040+00 to 2080+00 (SCL29)

STATE	PROJECT NO.	SECTION NO.	SHEET NO.
ND	IM-8-029(170)033	40	9

SPEC	CODE	BID ITEM	QTY	UNIT
202	0136	REMOVAL OF PAVEMENT Sta 2080+00 to 2120+00 Lt (Mainline)	10,611	TON
202	0169	REMOVAL OF END SECTION-ALL TYPES & SIZES Sta 2108+94 - 11' Lt	1	EA
		Sta 2108+94 - 111' Lt	1	EA

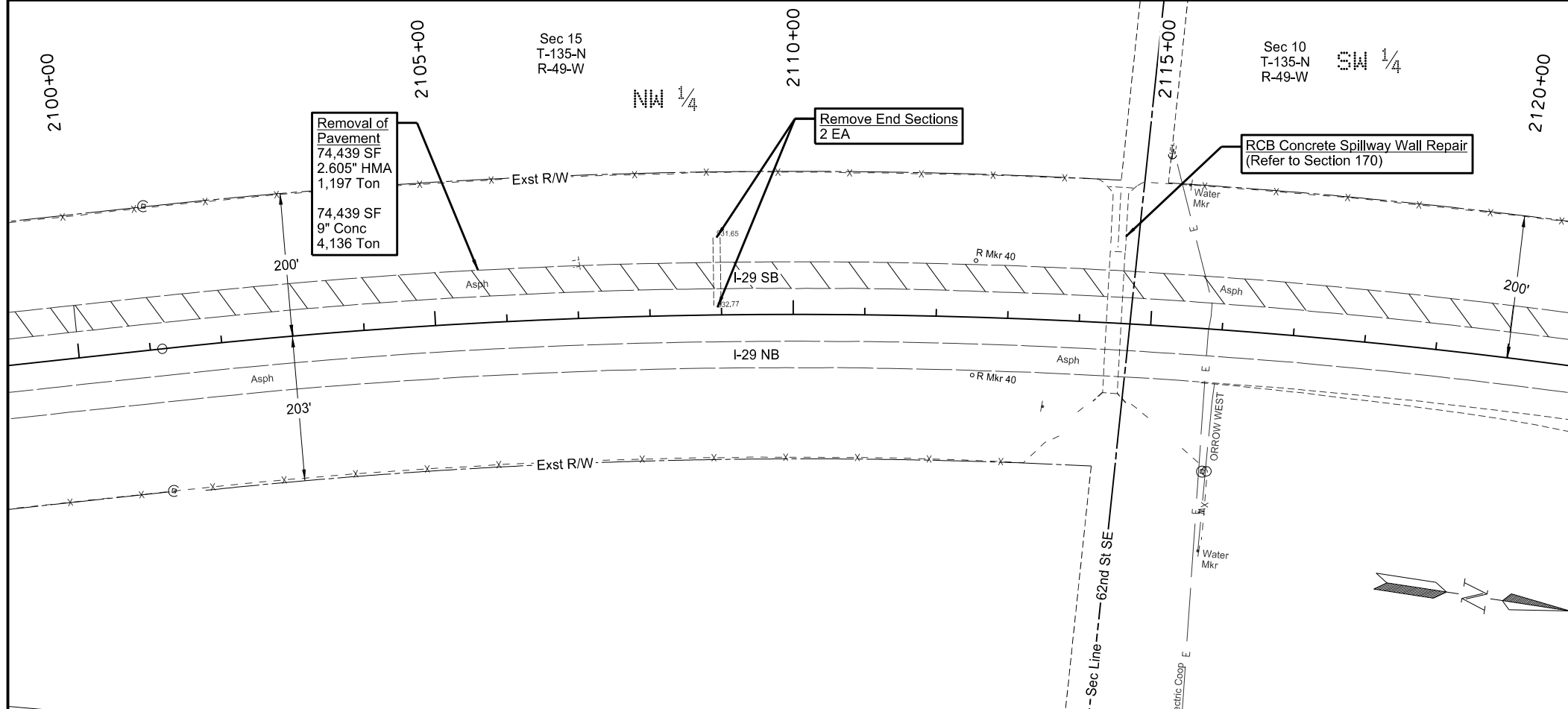
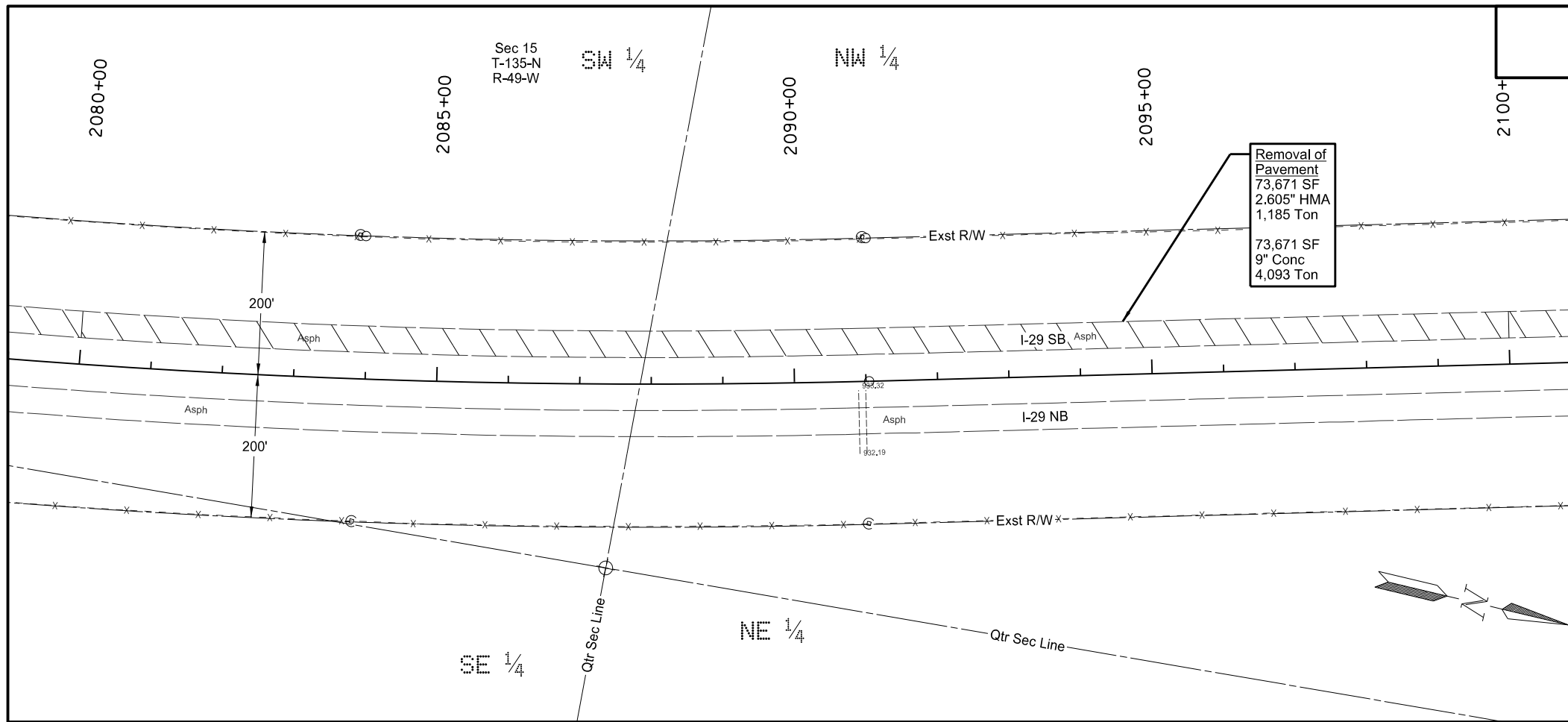

Notes:
1. Refer to Section 170 for RCB concrete spillway repair removals.

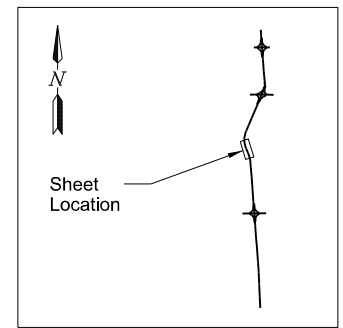

- Removal of Pavement (Concrete)
- Removal of Pavement (Asphalt & Concrete)
- Pavement Removal Limits

This document was originally issued and sealed by
Chad A. Petersen,
Registration Number
PE- 4884,
on 08/07/17 and the original document is stored at the
North Dakota Department
of Transportation

I-29 - N of Galchutt Exit to Christine Exit
Removals - Phase 3
Interstate 29
Sta 2080+00 to 2120+00 (SCL29)

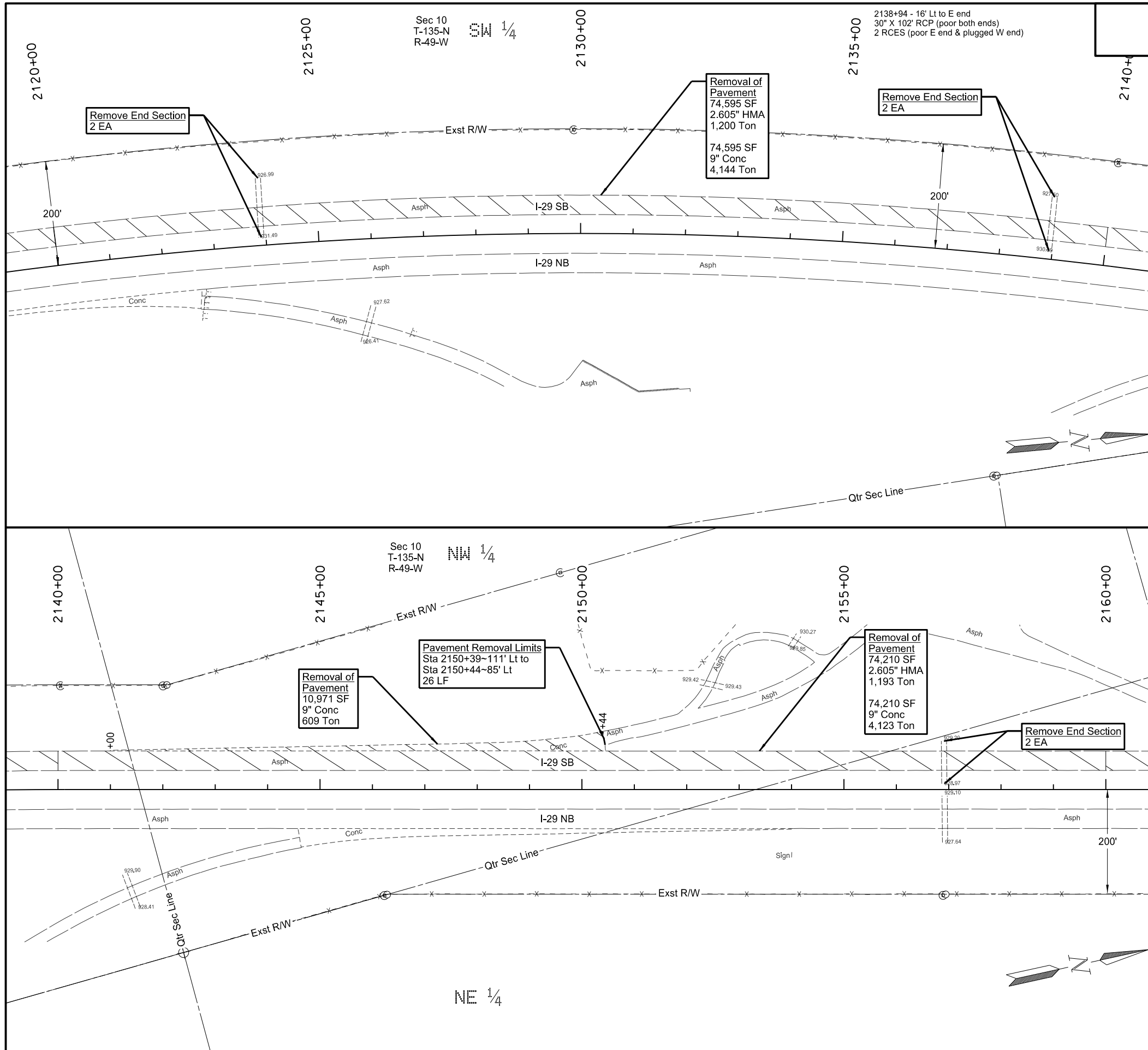

STATE	PROJECT NO.	SECTION NO.	SHEET NO.
ND	IM-8-029(170)033	40	10

SPEC	CODE	BID ITEM	QTY	UNIT
202	0136	REMOVAL OF PAVEMENT		
		Sta 2120+00 to 2160+00 Lt (Mainline)	10,660	TON
		Sta 2141+00 to 2150+44 Lt (Rest Area Taper)	609	TON
202	0169	REMOVAL OF END SECTION-ALL TYPES & SIZES		
		Sta 2123+92 - 14' Lt	1	EA
		Sta 2123+92 - 130' Lt	1	EA
		Sta 2138+94 - 14' Lt	1	EA
		Sta 2138+94 - 120' Lt	1	EA
		Sta 2156+91 - 95' Lt	1	EA
		Sta 2156+91 - 9' Lt	1	EA

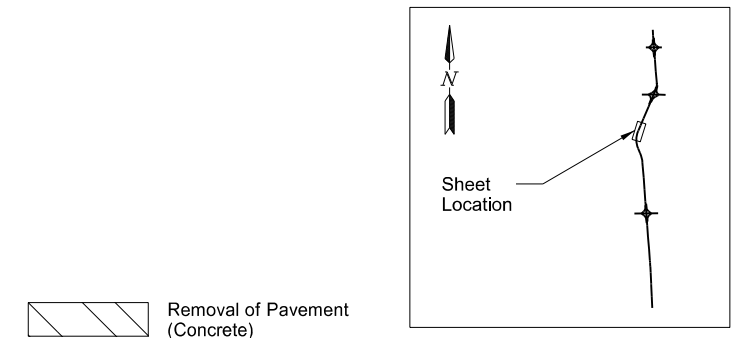



This document was originally issued and sealed by
 Chad A. Petersen,
 Registration Number
 PE- 4884,
 on 08/07/17 and the original document is stored at the
 North Dakota Department
 of Transportation

I-29 - N of Galchutt Exit to Christine Exit
 Removals - Phase 3
 Interstate 29
 Sta 2120+00 to 2160+00 (SCL29)

STATE	PROJECT NO.	SECTION NO.	SHEET NO.
ND	IM-8-029(170)033	40	11

SPEC	CODE	BID ITEM	QTY	UNIT
202	0130	REMOVAL OF CURB & GUTTER		
		Sta 2197+40 to 2197+60 Lt	20	LF
		Sta 2197+40 to 2197+60 Lt Mdn	20	LF
		Sta 2168+09 - 162 Lt to Sta 2168+13 - 122 Lt	40	LF
		Sta 2168+42 - 121 Rt to Sta 2168+46 - 161 Rt	40	LF
		Sta 2168+31 - 165 Lt to Sta 2168+36 - 125 Lt	40	LF
		Sta 2168+64 - 118 Rt to Sta 2168+69 - 158 Rt	40	LF
202	0136	REMOVAL OF PAVEMENT		
		Sta 2160+00 to 2200+00 Lt (Mainline)	9,894	TON
		Sta 2163+38 to 2170+05 Lt (Rest Area Taper)	438	TON
202	0169	REMOVAL OF END SECTION-ALL TYPES & SIZES		
		Sta 2166+93 - 108' Lt	1	EA
		Sta 2173+94 - 5' Lt	1	EA
		Sta 2173+94 - 103' Lt	1	EA
		Sta 2189+93 - 10' Lt	1	EA
		Sta 2189+93 - 104' Lt	1	EA

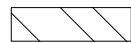
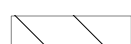
Notes:
1. Refer to Section 130 for guardrail removal quantities.

-  Removal of Pavement (Concrete)
-  Removal of Pavement (Asphalt & Concrete)
-  Pavement Removal Limits

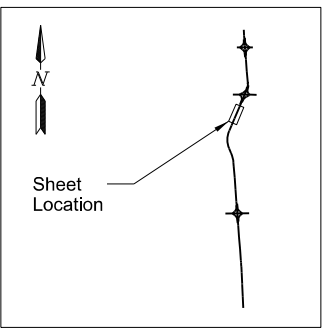

This document was originally issued and sealed by
Chad A. Petersen,
Registration Number
PE- 4884,
on 08/07/17 and the original document is stored at the
North Dakota Department
of Transportation

I-29 - N of Galchutt Exit to Christine Exit
Removals - Phase 3
Interstate 29
Sta 2160+00 to 2200+00 (SCL29)

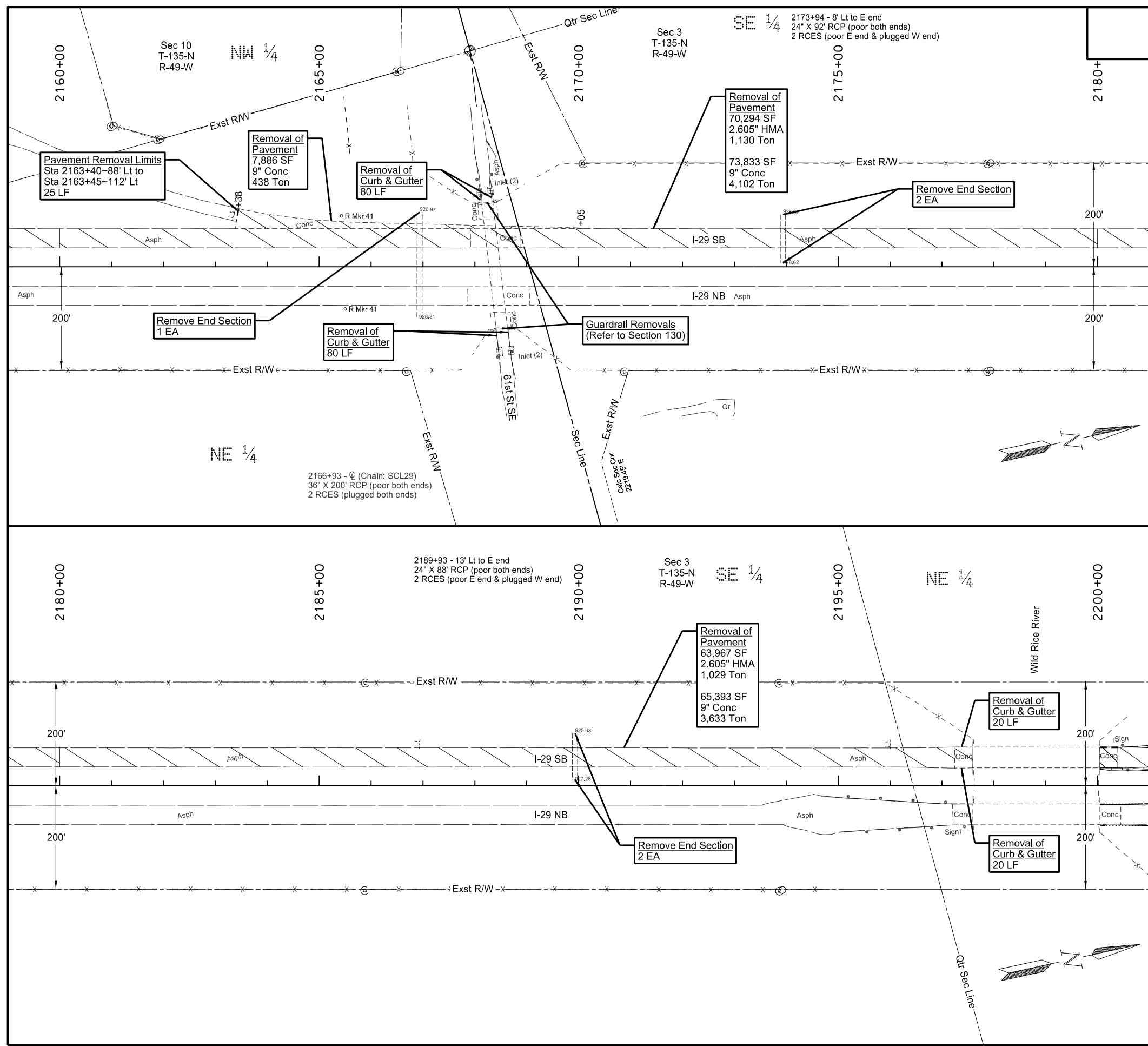

STATE	PROJECT NO.	SECTION NO.	SHEET NO.
ND	IM-8-029(170)033	40	12

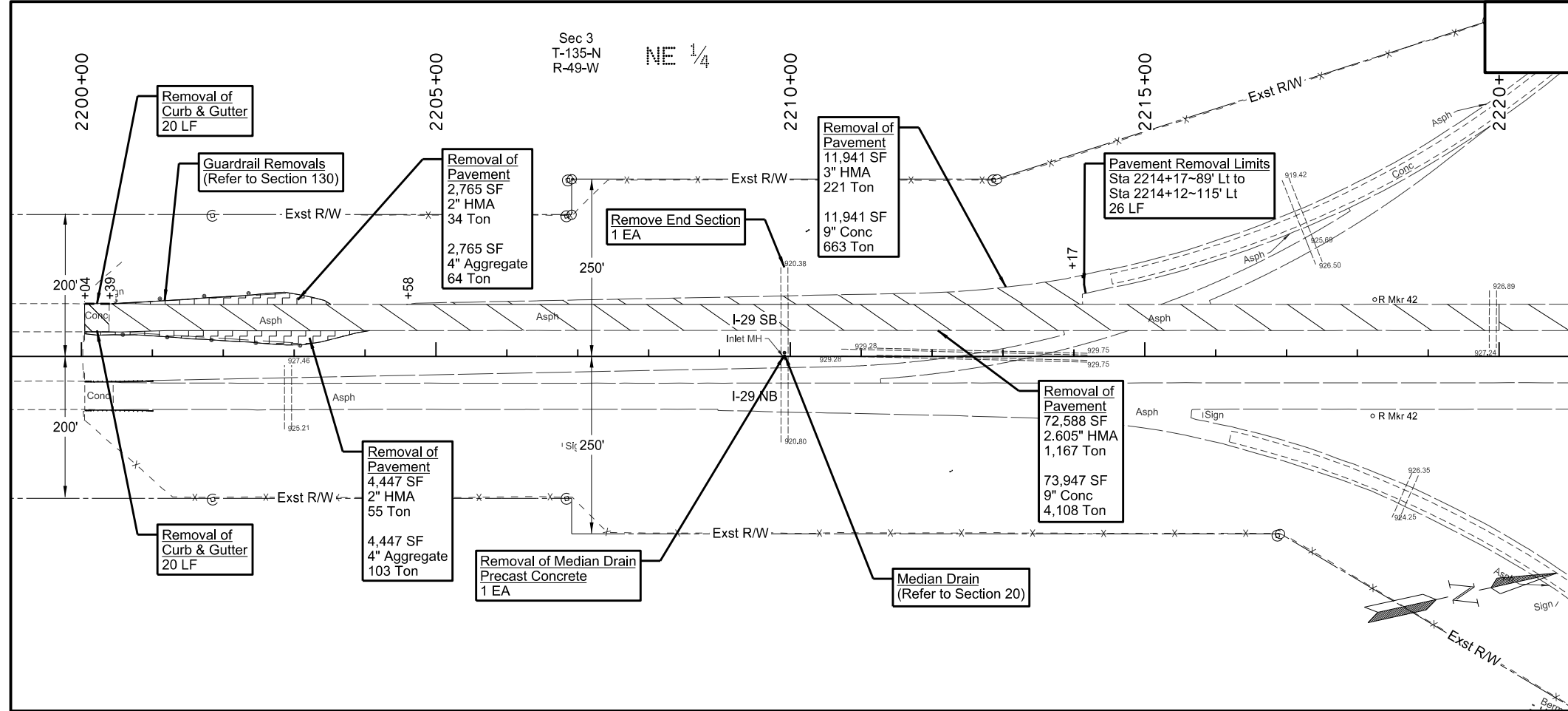

SPEC	CODE	BID ITEM	QTY	UNIT
202	0130	REMOVAL OF CURB & GUTTER		
		Sta 2200+04 to 2200+24 Lt	20	LF
		Sta 2200+04 to 2200+24 Lt Mdn	20	LF
202	0136	REMOVAL OF PAVEMENT		
		Sta 2200+00 to 2240+00 Lt (Mainline)	10,528	TON
		Sta 2200+04 to 2203+52 Lt (Guardrail Grading)	98	TON
		Sta 2200+04 to 2204+06 Lt Mdn (Guardrail Grading)	158	TON
		Sta 2204+58 to 2214+17 Lt (Ramp Taper)	884	TON
		Sta 2233+26 to 2240+00 Lt (Ramp Taper)	596	TON
202	0169	REMOVAL OF END SECTION-ALL TYPES & SIZES		
		Sta 2209+92 - 128' Lt	1	EA
		Sta 2219+91 - 9' Lt	1	EA
		Sta 2219+91 - 96' Lt	1	EA
		Sta 2229+91 - 8' Lt	1	EA
		Sta 2229+91 - 95' Lt	1	EA
202	0237	REMOVAL OF MEDIAN DRAIN PRECAST CONCRETE		
		Sta 2209+92 - 5.2' Lt	1	EA

- Notes:
1. Refer to Section 130 for guardrail removal quantities.
 2. Refer to Section 170 for overhead bridge mounted sign structure removals.
 3. Existing precast concrete median drain to be relayed. Refer to Sections 20 and 60 for additional information.

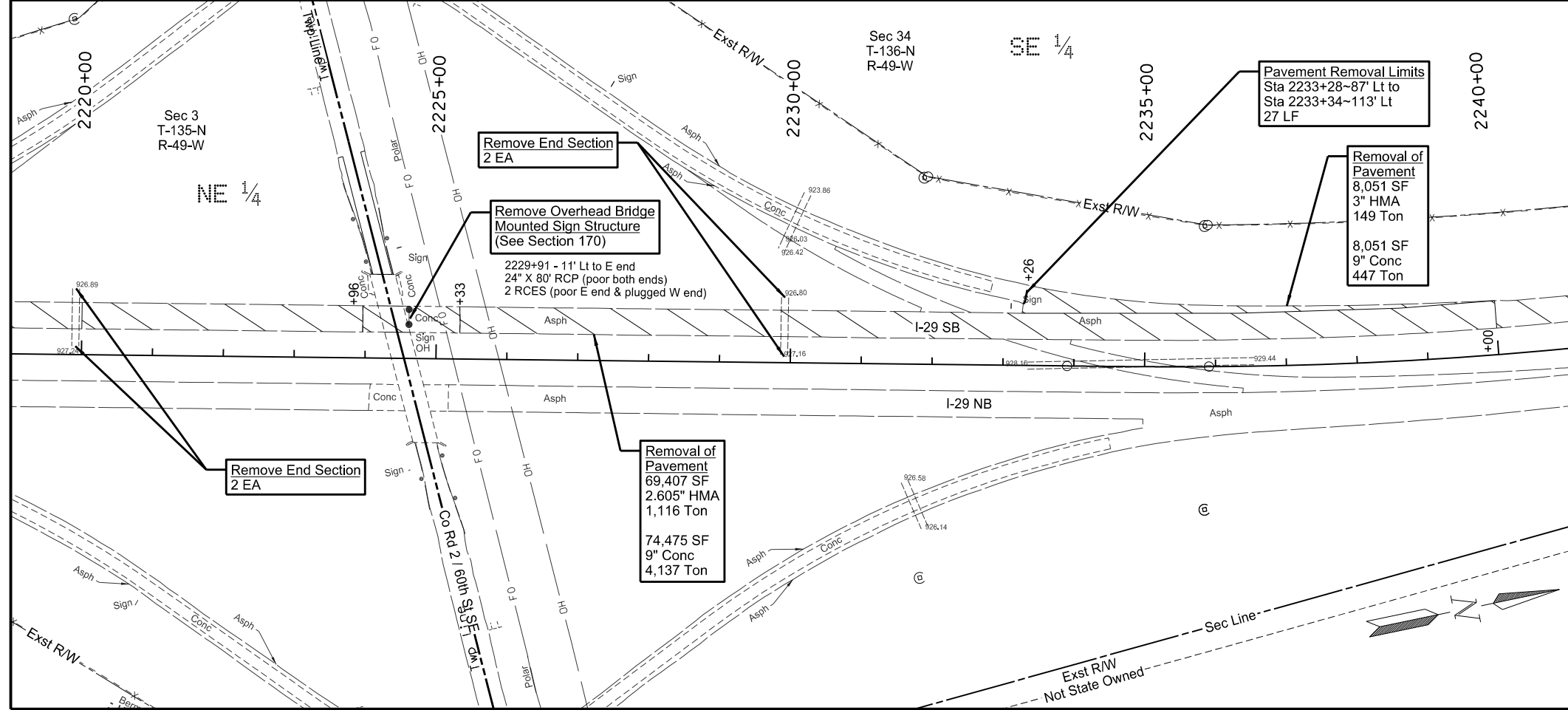

- Removal of Pavement (Guardrail Grading)
- Removal of Pavement (Concrete)
- Removal of Pavement (Asphalt & Concrete)
- Pavement Removal Limits

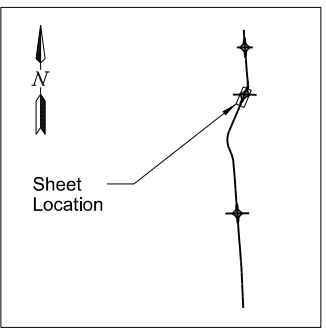



This document was originally issued and sealed by
 Chad A. Petersen,
 Registration Number
 PE- 4884,
 on 08/07/17 and the original document is stored at the
 North Dakota Department
 of Transportation

I-29 - N of Galchutt Exit to Christine Exit
 Removals - Phase 3
 Interstate 29
 Sta 2200+00 to 2240+00 (SCL29)

STATE	PROJECT NO.	SECTION NO.	SHEET NO.
ND	IM-8-029(170)033	40	13

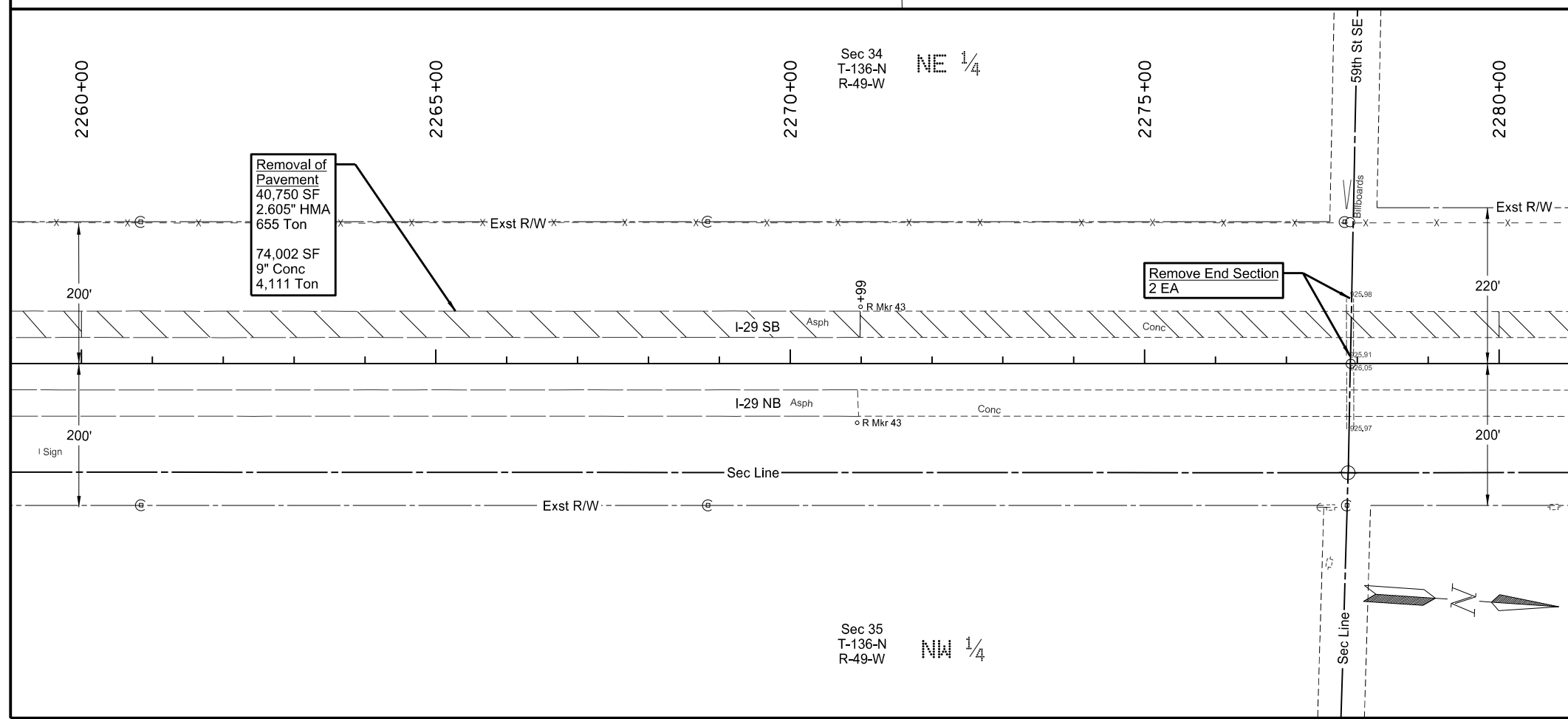
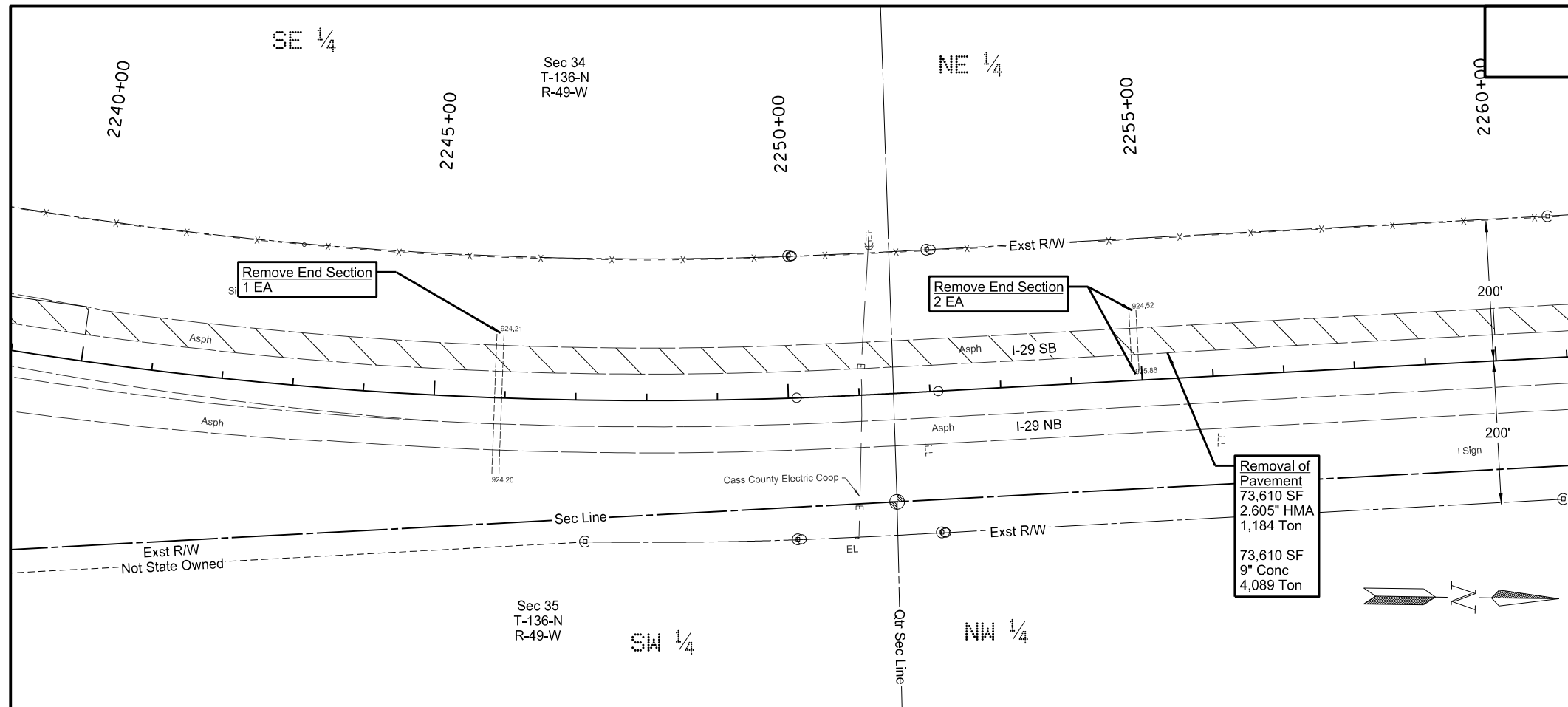
SPEC	CODE	BID ITEM	QTY	UNIT
202	0136	REMOVAL OF PAVEMENT Sta 2240+00 to 2280+00 Lt (Mainline)	10,039	TON
202	0169	REMOVAL OF END SECTION-ALL TYPES & SIZES		
		Sta 2245+90 - 94' Lt	1	EA
		Sta 2254+91 - 9' Lt	1	EA
		Sta 2254+91 - 101' Lt	1	EA
		Sta 2277+90 - 9' Lt	1	EA
		Sta 2277+90 - 94' Lt	1	EA

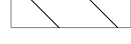
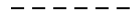

-  Removal of Pavement (Concrete)
-  Removal of Pavement (Asphalt & Concrete)
-  Pavement Removal Limits

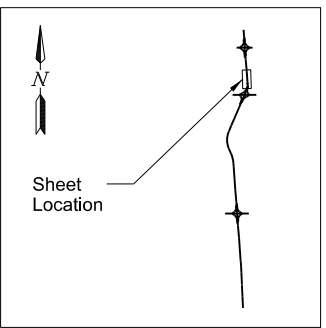

This document was originally issued and sealed by
 Chad A. Petersen,
 Registration Number
 PE- 4884,
 on 08/07/17 and the original document is stored at the
 North Dakota Department
 of Transportation

I-29 - N of Galchutt Exit to Christine Exit
 Removals - Phase 3
 Interstate 29
 Sta 2240+00 to 2280+00 (SCL29)

STATE	PROJECT NO.	SECTION NO.	SHEET NO.
ND	IM-8-029(170)033	40	14

SPEC	CODE	BID ITEM	QTY	UNIT
202	0136	REMOVAL OF PAVEMENT		
		Sta 2280+00 to 2320+00 Lt (Mainline)	9,166	TON
		Sta 2311+45 to 2320+00 Lt (Ramp Taper)	584	TON
202	0169	REMOVAL OF END SECTION-ALL TYPES & SIZES		
		Sta 2290+30 - 10' Lt	1	EA
		Sta 2290+30 - 98' Lt	1	EA
		Sta 2299+20 - 96' Lt	1	EA
		Sta 2290+40 - 96' Lt	1	EA
		Sta 2312+32 - 10' Lt	1	EA
		Sta 2312+32 - 96' Lt	1	EA

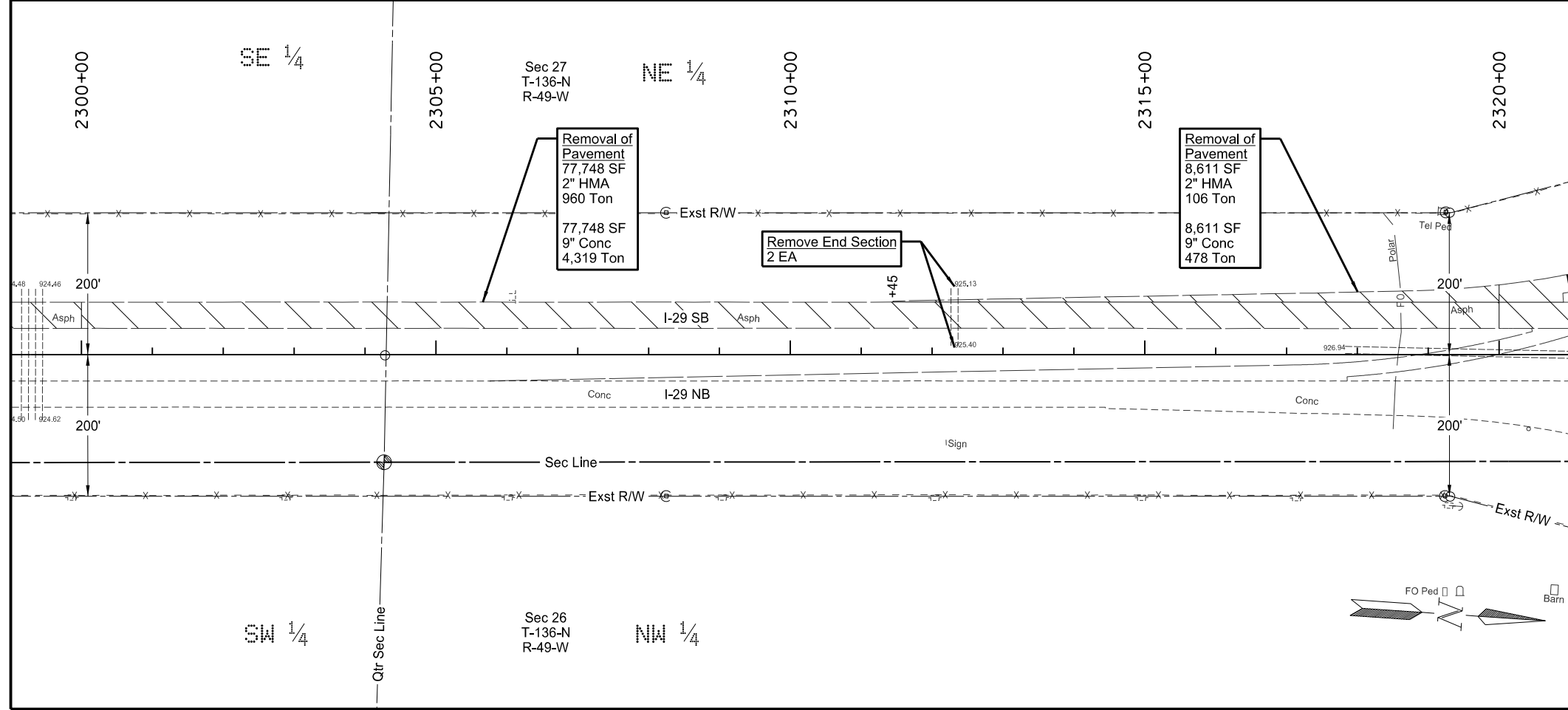
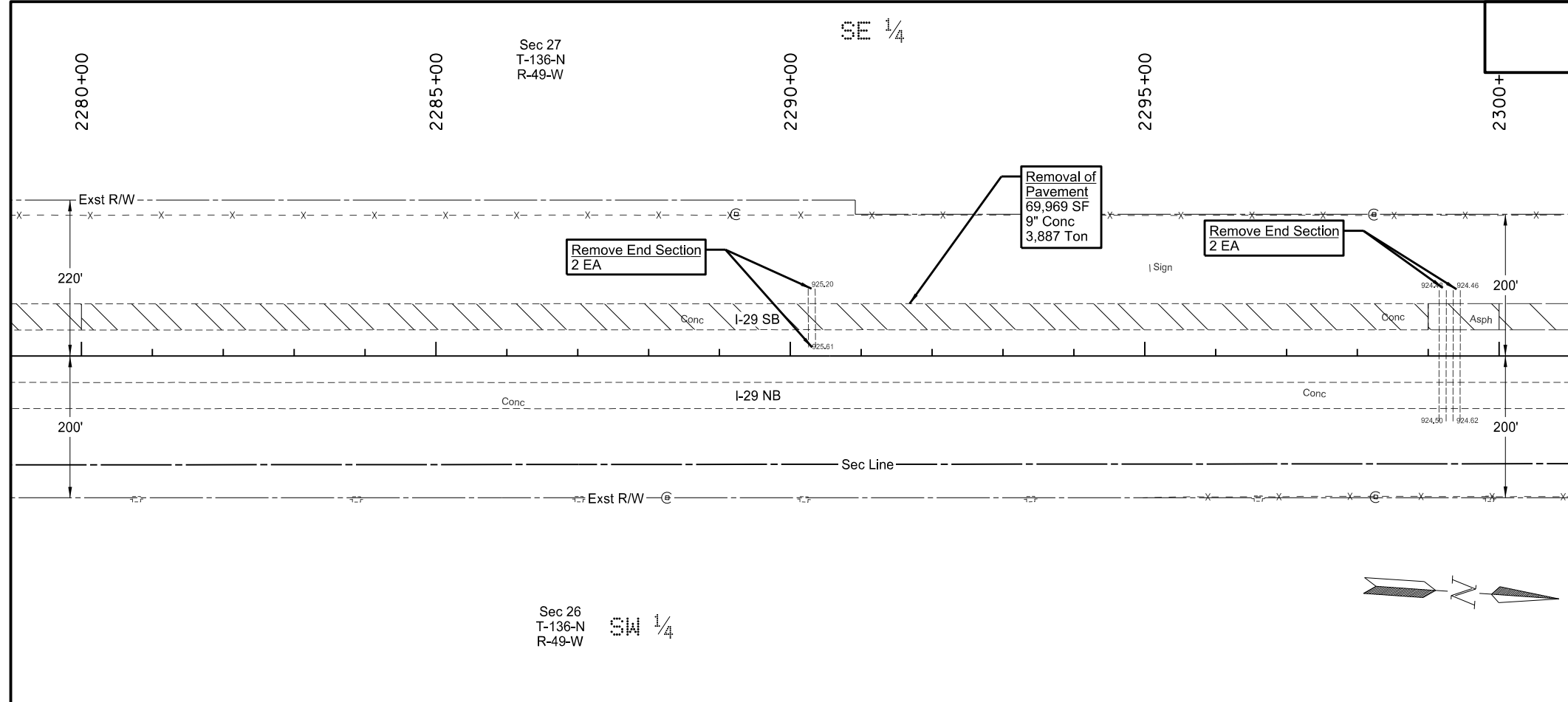

- Removal of Pavement (Concrete)
- Removal of Pavement (Asphalt & Concrete)
- Pavement Removal Limits

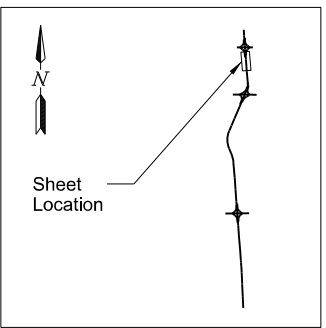

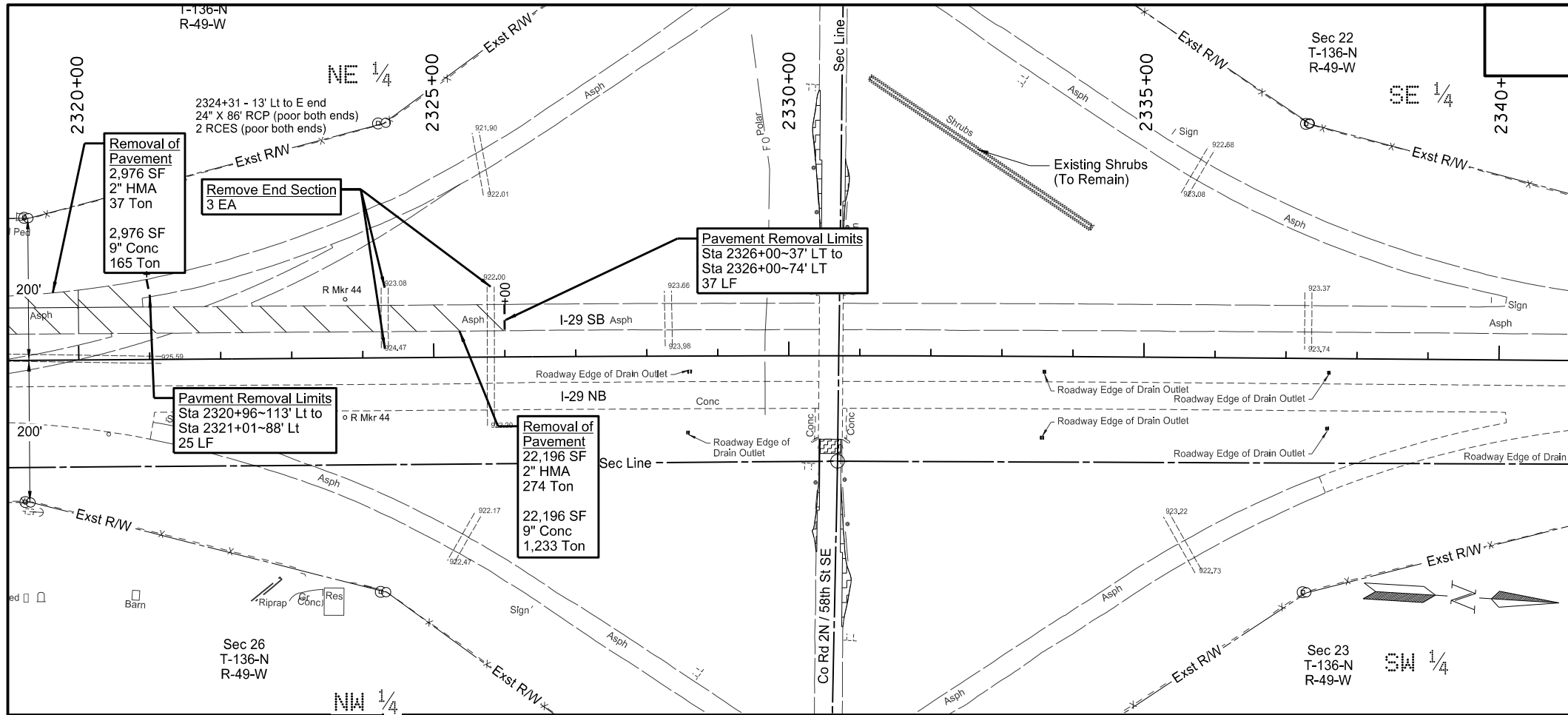

This document was originally issued and sealed by
 Chad A. Petersen,
 Registration Number
 PE- 4884,
 on 08/07/17 and the original document is stored at the
 North Dakota Department
 of Transportation

I-29 - N of Galchutt Exit to Christine Exit
 Removals - Phase 3
 Interstate 29
 Sta 2280+00 to 2320+00 (SCL29)

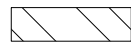
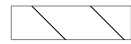

STATE	PROJECT NO.	SECTION NO.	SHEET NO.
ND	IM-8-029(170)033	40	15

SPEC	CODE	BID ITEM	QTY	UNIT
202	0136	REMOVAL OF PAVEMENT		
		Sta 2320+00 to 2326+00 Lt (Mainline)	1,507	TON
		Sta 2320+00 to 2320+91 Lt (Ramp Taper)	202	TON
202	0169	REMOVAL OF END SECTION-ALL TYPES & SIZES		
		Sta 2324+31 - 10' Lt	1	EA
		Sta 2324+31 - 101' Lt	1	EA
		Sta 2325+80 - 102' Lt	1	EA

-  Removal of Pavement (Concrete)
-  Removal of Pavement (Asphalt & Concrete)
-  Pavement Removal Limits

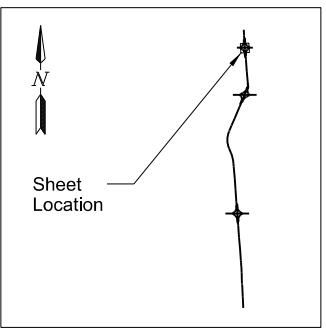

This document was originally issued and sealed by Chad A. Petersen, Registration Number PE- 4884, on 08/07/17 and the original document is stored at the North Dakota Department of Transportation

I-29 - N of Galchutt Exit to Christine Exit
Removals - Phase 3
Interstate 29
Sta 2320+00 to 2326+00 (SCL29)

STATE	PROJECT NO.	SECTION NO.	SHEET NO.
ND	IM-8-029(170)033	40	16

SPEC	CODE	BID ITEM	QTY	UNIT
202	0132	REMOVAL OF BITUMINOUS SURFACING		
		Sta 1200+00 to 1215+81 (Phase 4)	2,444	SY
		Sta 1216+37 to 1220+41 (Phase 5)	603	SY
		Sta 1301+46 to 1305+14 (Phase 5)	616	SY
		Sta 1305+68 to 1317+66 (Phase 4)	1,734	SY
202	0169	REMOVAL OF END SECTION-ALL TYPES & SIZES		
		Sta 1220+48 - 43' Rt	1	EA
		Sta 1220+54 - 28' Lt	1	EA
		Sta 1220+56 - 44' Rt	1	EA
		Sta 1220+62 - 27' Lt	1	EA
		Sta 1301+08 - 32' Lt	1	EA
		Sta 1301+14 - 47' Rt	1	EA
202	0174	REMOVAL OF PIPE ALL TYPES AND SIZES		
		Sta 1212+38 - 24' Lt to Sta 1212+88 - 18' Lt	49	LF
202	0350	REMOVAL OF TEMPORARY BYPASS		
		Sta 1200+00 to 1220+41 (Phase 4 & 5)	1	EA
		Sta 1301+46 to 1317+66 (Phase 4 & 5)	1	EA

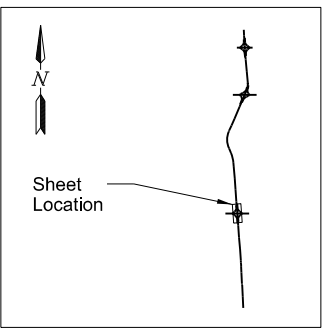
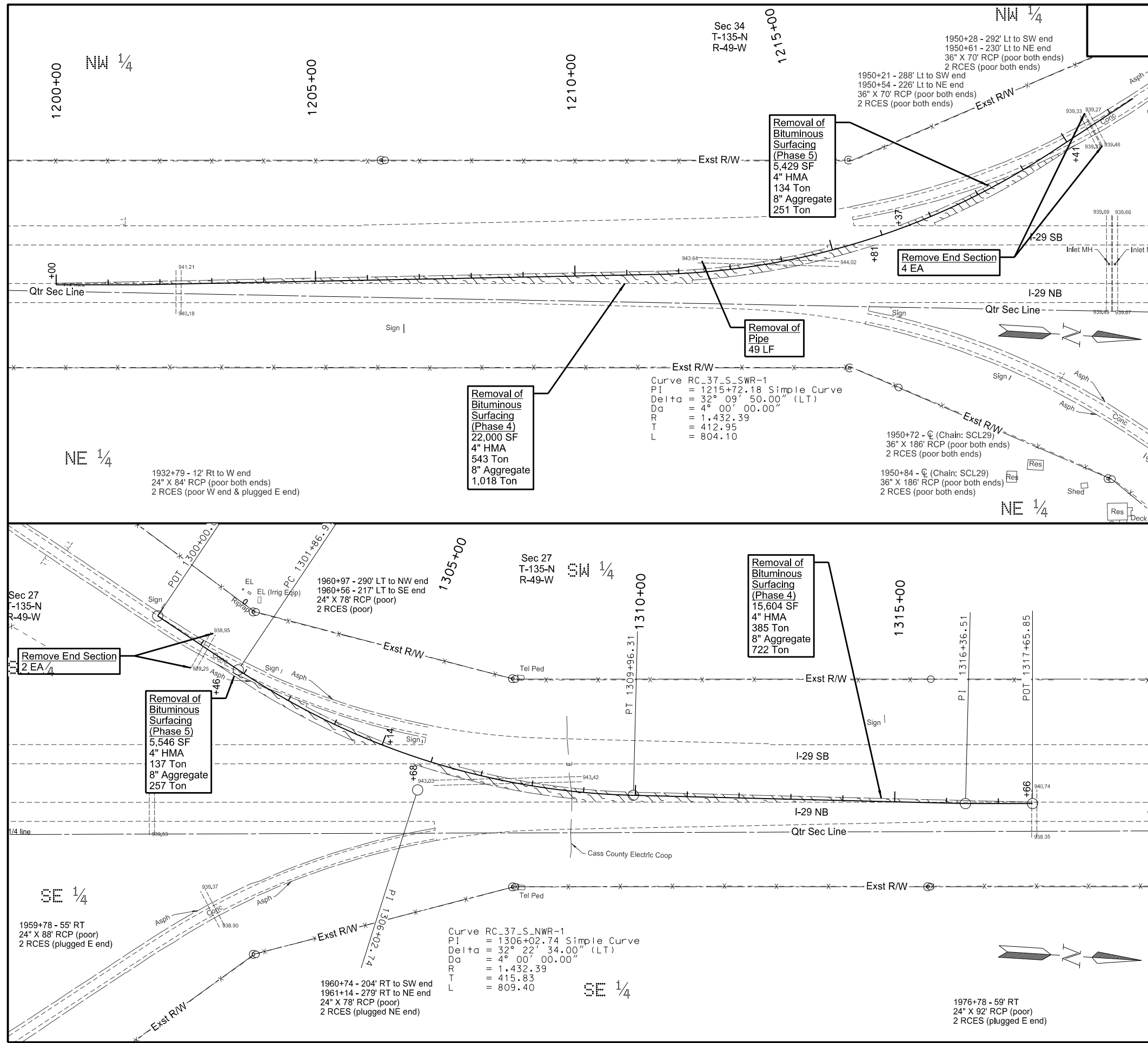

- Removal of Bituminous Surfacing
- Pavement Removal Limits

This document was originally issued and sealed by
 Chad A. Petersen,
 Registration Number
 PE- 4884,
 on 08/07/17 and the original document is stored at the
 North Dakota Department
 of Transportation

I-29 - N of Galchutt Exit to Christine Exit
 Removals - Phase 4 & 5
 Colfax Interchange SW & NW Ramp Connections
 Sta 1200+00 to 1220+41 (RC_37_S_SWR)
 Sta 1301+46 to 1317+66 (RC_37_S_NWR)

STATE	PROJECT NO.	SECTION NO.	SHEET NO.
ND	IM-8-029(170)033	40	17

SPEC CODE	BID ITEM	QTY	UNIT
202 0132	REMOVAL OF BITUMINOUS SURFACING		
	Sta 2200+00 to 2214+73 (Phase 4)	2,350	SY
	Sta 2215+27 to 2220+36 (Phase 5)	915	SY
	Sta 2300+61 to 2305+37 (Phase 5)	733	SY
	Sta 2305+92 to 2317+95 (Phase 4)	1,754	SY
202 0169	REMOVAL OF END SECTION-ALL TYPES & SIZES		
	Sta 2217+70 - 92' Lt	1	EA
	Sta 2302+49 - 54' Lt	1	EA
202 0174	REMOVAL OF PIPE ALL TYPES AND SIZES		
	Sta 2210+64 - 26' Lt to Sta 2211+52 - 18' Lt	87	LF
	Sta 2211+15 - 24' Lt to Sta 2211+19 - 24' Lt	4	LF
	Sta 2217+56 - 3' Rt to Sta 2217+52 - 35' Rt	32	LF
	Sta 2302+58 - 17' Rt to Sta 2302+60 - 33' Rt	16	LF
202 0350	REMOVAL OF TEMPORARY BYPASS		
	Sta 2200+00 to 2221+36 (Phase 4 & 5)	1	EA
	Sta 2300+61 to 2317+95 (Phase 4 & 5)	1	EA

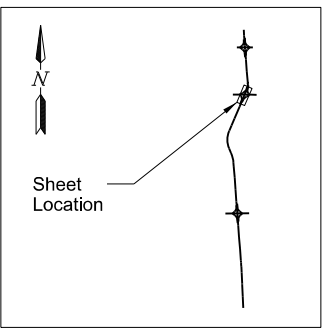
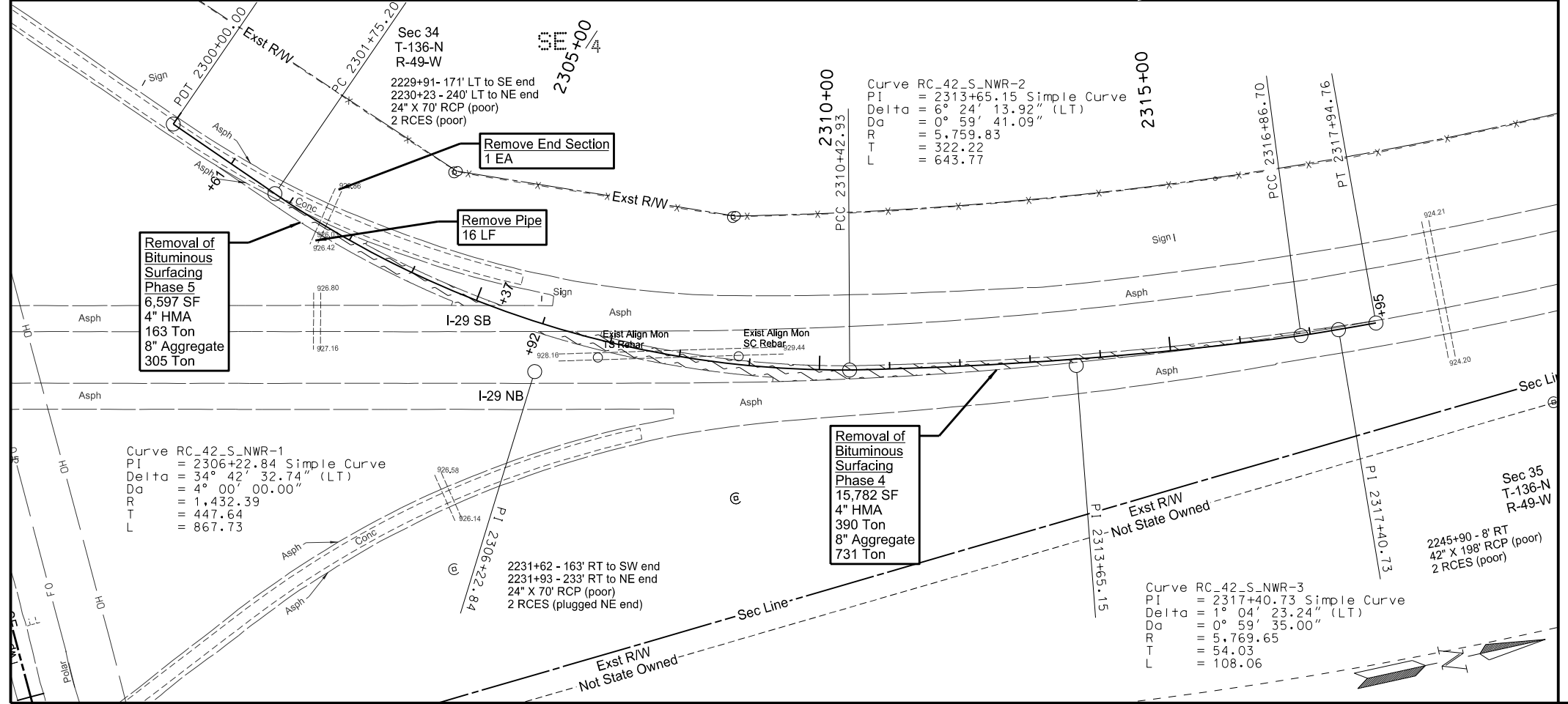
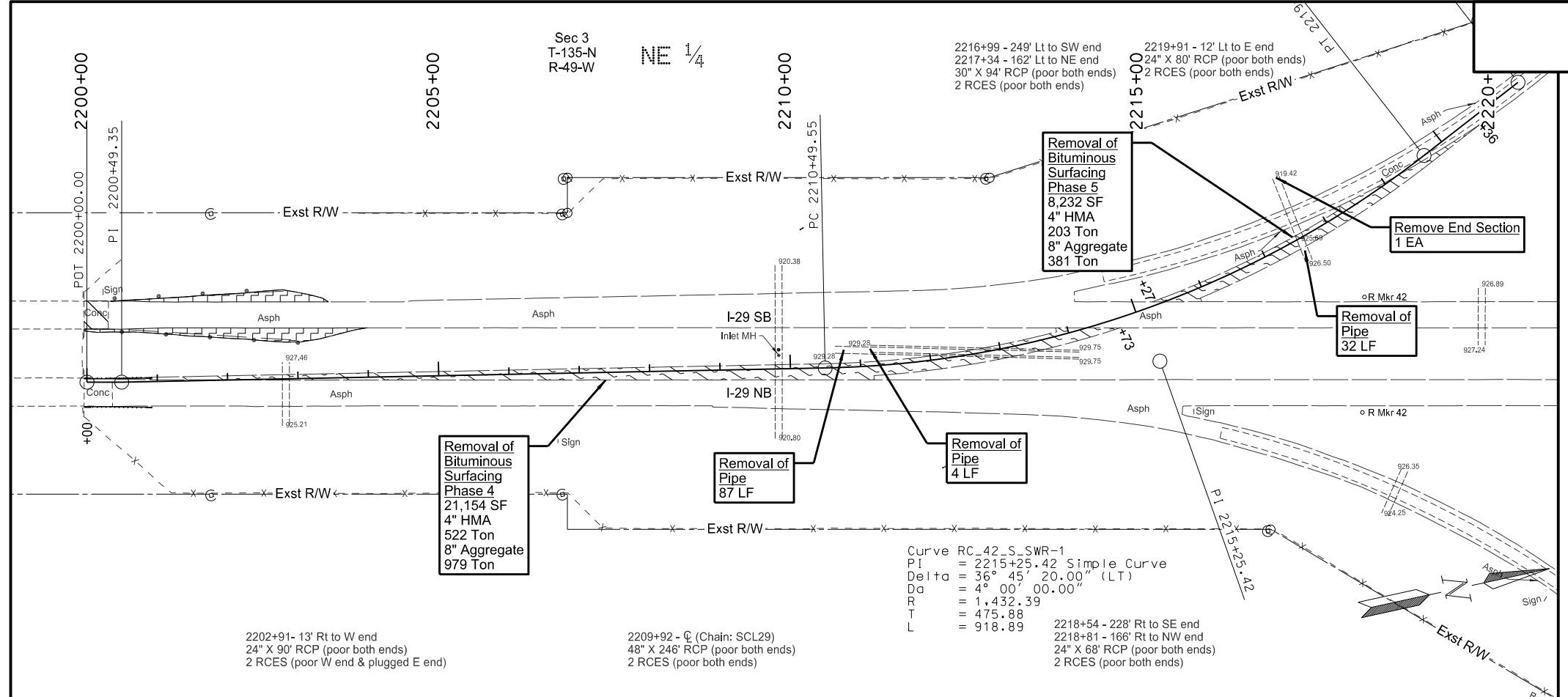

- Removal of Bituminous Surfacing
- Pavement Removal Limits

This document was originally issued and sealed by
 Chad A. Petersen,
 Registration Number
 PE- 4884,
 on 08/07/17 and the original document is stored at the
 North Dakota Department
 of Transportation

I-29 - N of Galchutt Exit to Christine Exit
 Removals - Phase 4 & 5
 Walcott Interchange SW & NW Ramp Connections
 Sta 2200+00 to 2221+36 (RC_42_S_SWR)
 Sta 2300+61 to 2317+95 (RC_42_S_NWR)

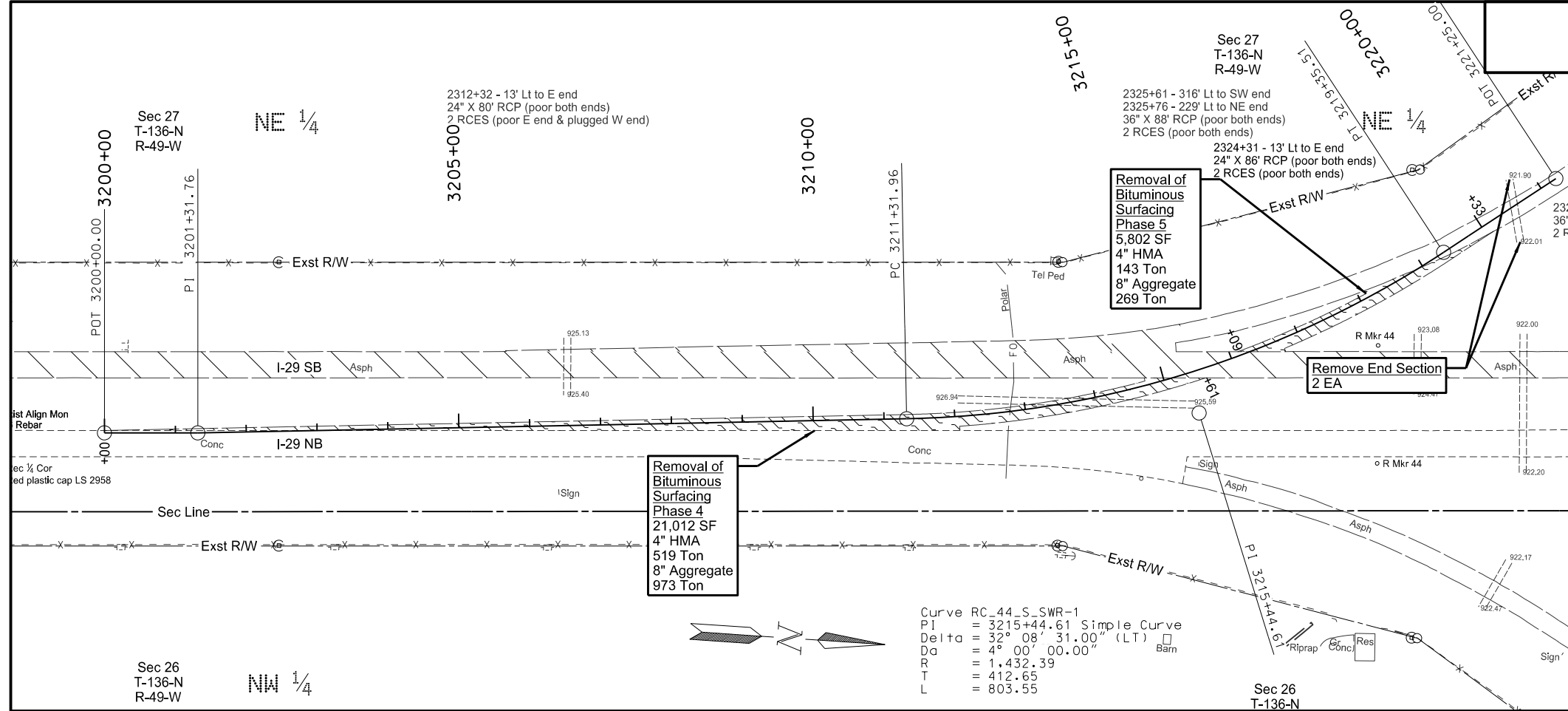

SPEC	CODE	BID ITEM	QTY	UNIT
202	0132	REMOVAL OF BITUMINOUS SURFACING		
		Sta 3200+00 to 3215+61 (Phase 4)	2,335	SY
		Sta 3216+09 to 3220+33 (Phase 5)	645	SY
202	0169	REMOVAL OF END SECTION-ALL TYPES & SIZES		
		Sta 3220+34 - 47' Rt	1	EA
		Sta 3220+70 - 35' Lt	1	EA
202	0350	REMOVAL OF TEMPORARY BYPASS		
		Sta 3200+00 to 3220+33 (Phase 4 & 5)	1	EA

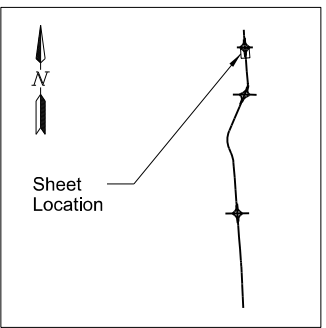

- Removal of Bituminous Surfacing
- Pavement Removal Limits

This document was originally issued and sealed by
 Chad A. Petersen,
 Registration Number
 PE- 4884,
 on 08/07/17 and the original document is stored at the
 North Dakota Department
 of Transportation

I-29 - N of Galchutt Exit to Christine Exit
 Removals - Phase 4 & 5
 Christine Interchange SW Ramp Connection
 Sta 3200+00 to 3220+33 (RC_44_S_SWR)

STATE	PROJECT NO.	SECTION NO.	SHEET NO.
ND	IM-8-029(170)033	40	19

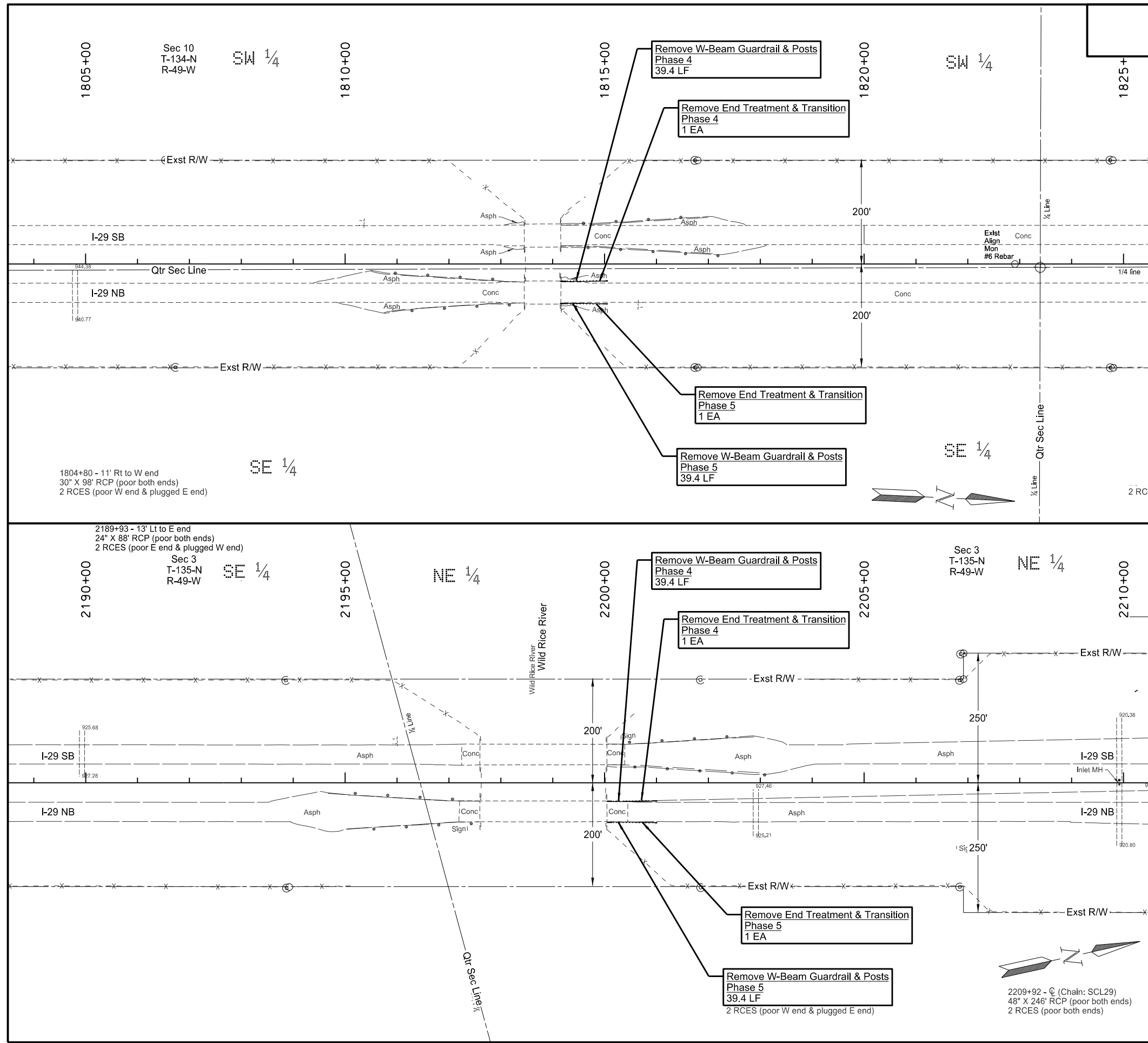

Notes:
1. Temporary guardrail removals are not paid for separately but rather included in the contract unit price for "W-BEAM GUARDRAIL END TERMINAL"

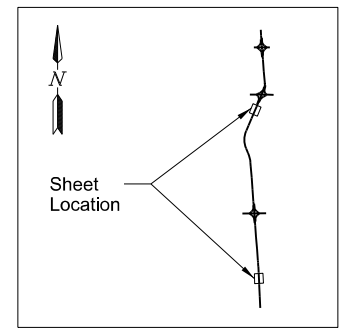

This document was originally issued and sealed by
Chad A. Petersen,
Registration Number
PE- 4884,
on 08/07/17 and the original document is stored at the
North Dakota Department
of Transportation

I-29 - N of Galchutt Exit to Christine Exit
Removals - Phase 4 & 5
Guardrail - Pitcairn Creek & Wild Rice River
Sta 1805+00 to 1825+00 (SCL29)
Sta 2190+00 to 2210+00 (SCL29)

STATE	PROJECT NO.	SECTION NO.	SHEET NO.
ND	IM-8-029(170)033	40	20

SPEC	CODE	BID ITEM	QTY	UNIT
411	0105	MILLING PAVEMENT SURFACE		
		Sta 12+29 to 22+23 (SW Ramp)	1,334	SY
		Sta 7+60 to 8+60 (Co Rd 4/Colfax Ave)	353	SY
		Sta 11+30 to 13+83 (Co Rd 4/Colfax Ave)	1,022	SY
		Sta 1+13 to 10+82 (NW Ramp)	1,216	SY

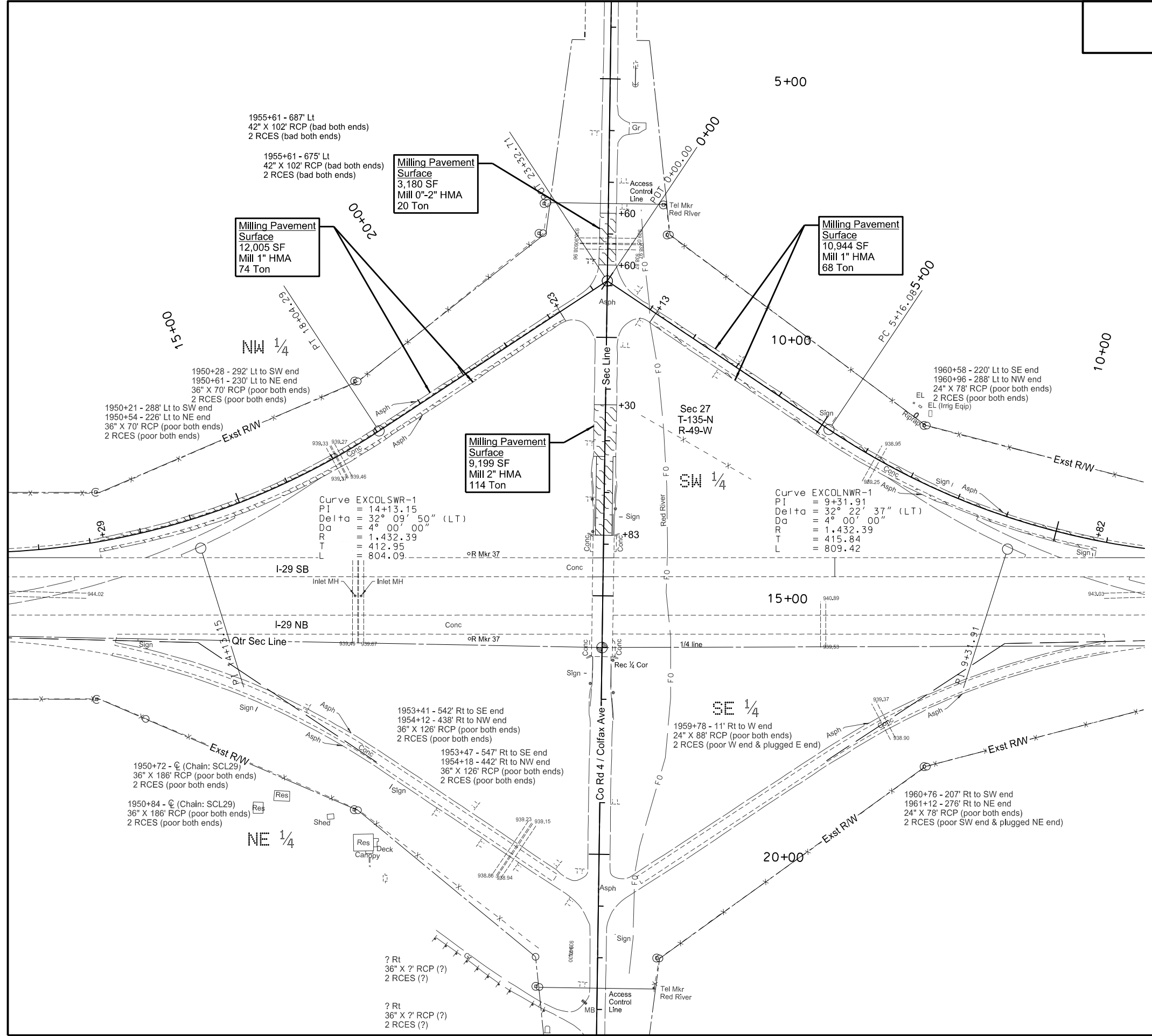

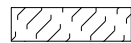
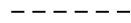
 Milling Pavement Surface
 Pavement Removal Limits

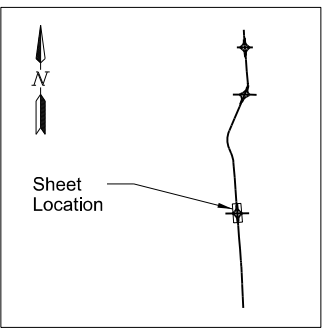

This document was originally issued and sealed by
Chad A. Petersen,
 Registration Number
PE- 4884,
 on 08/07/17 and the original document is stored at the
 North Dakota Department
 of Transportation

I-29 - N of Galchutt Exit to Christine Exit
Removals - Phase 5
 Colfax Interchange Improvements
 Sta 12+29 to 22+23 (EXCOLSWR)
 Sta 7+60 to 13+83 (EXCOLFAX)
 Sta 1+13 to 10+82 (EXCOLNWR)

STATE	PROJECT NO.	SECTION NO.	SHEET NO.
ND	IM-8-029(170)033	40	21

SPEC	CODE	BID ITEM	QTY	UNIT
411	0105	MILLING PAVEMENT SURFACE		
		Sta 12+29 to 21+61 (SW Ramp)	1,307	SY
		Sta 17+60 to 23+81 (Co Rd 2/60 St SE)	2,851	SY
		Sta 0+92 to 11+55 (NW Ramp)	1,430	SY

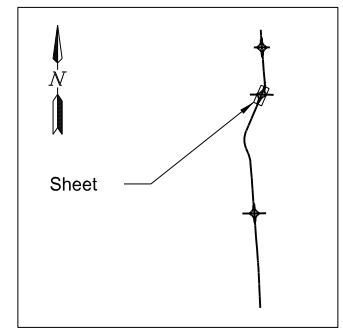
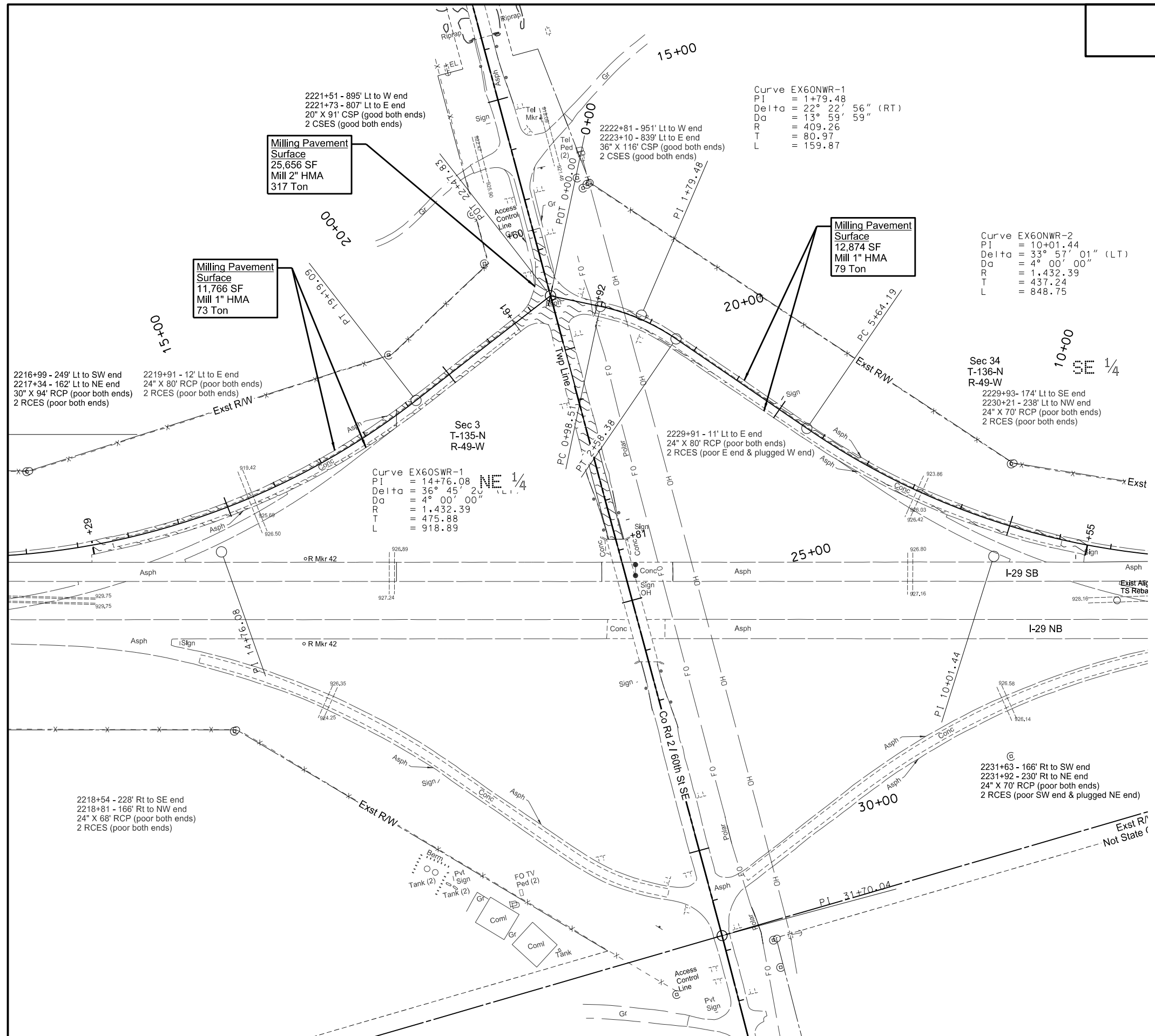

- Milling Pavement Surface
- Pavement Removal Limits

This document was originally issued and sealed by
Chad A. Petersen,
 Registration Number
PE- 4884,
 on 08/07/17 and the original document is stored at the
 North Dakota Department
 of Transportation

I-29 - N of Galchutt Exit to Christine Exit

Removals - Phase 5
 Walcott Interchange Improvements
 Sta 12+68 to 21+61 (EX60SWR)
 Sta 17+60 to 23+81 (EX60ST)
 Sta 0+92 to 11+55 (EX60NWR)

STATE	PROJECT NO.	SECTION NO.	SHEET NO.
ND	IM-8-029(170)033	40	22

SPEC	CODE	BID ITEM	QTY	UNIT
202	0132	REMOVAL OF BITUMINOUS SURFACING		
		Sta 14+28 to 16+84 (Phase 5)	55	SY
		Sta 19+19 to 21+83 (Phase 5)	49	SY
		Sta 16+64 to 16+84 (Phase 5)	67	SY
		Sta 19+19 to 19+39 (Phase 5)	65	SY
411	0105	MILLING PAVEMENT SURFACE		
		Sta 10+62 to 16+64	2,363	SY
		Sta 19+39 to 25+42	2,345	SY

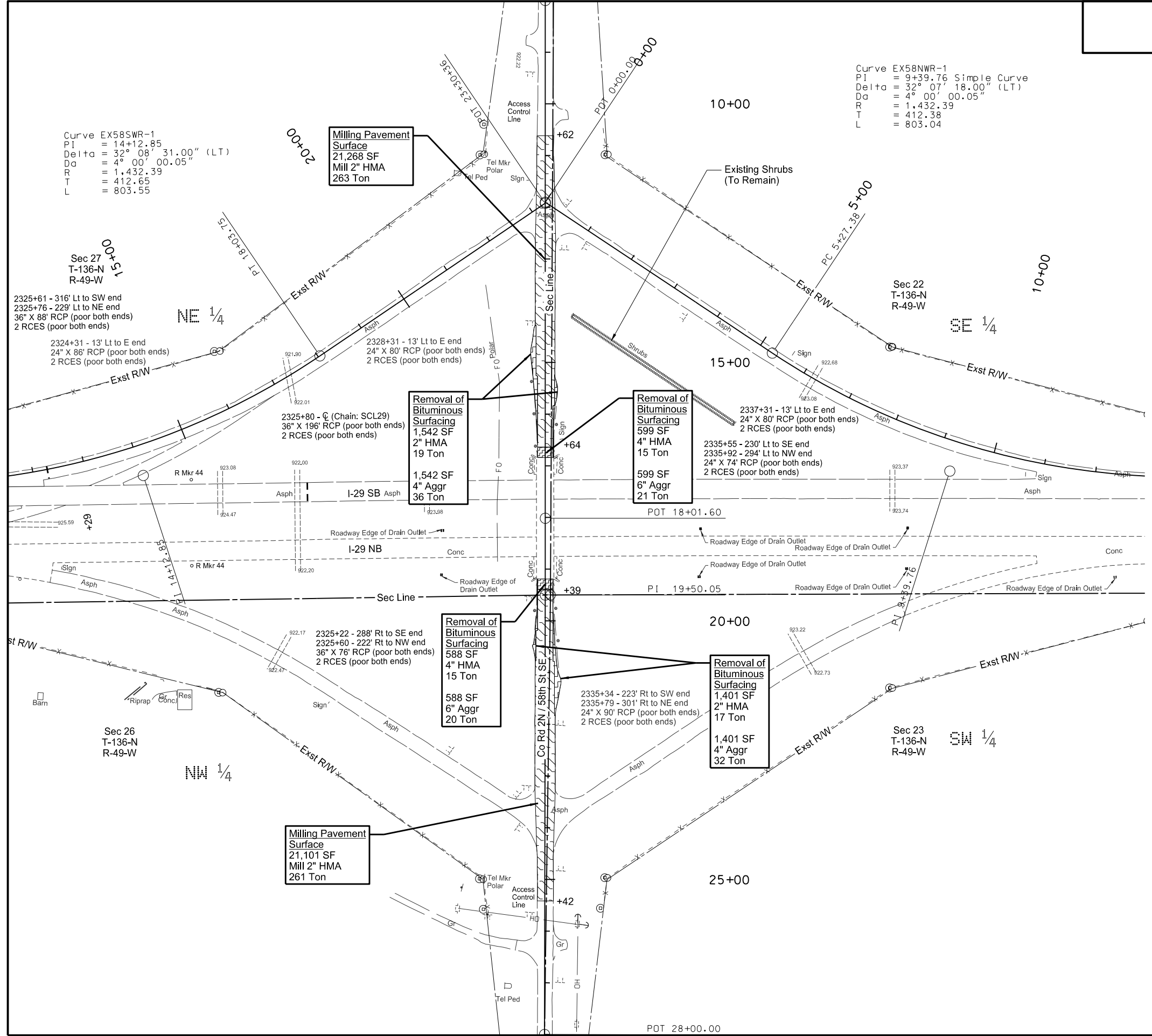

Curve EX58NWR-1
 PI = 9+39.76 Simple Curve
 Delta = 32° 07' 18.00" (LT)
 Da = 4° 00' 00.05"
 R = 1,432.39
 T = 412.38
 L = 803.04

Curve EX58SWR-1
 PI = 14+12.85
 Delta = 32° 08' 31.00" (LT)
 Da = 4° 00' 00.05"
 R = 1,432.39
 T = 412.65
 L = 803.55

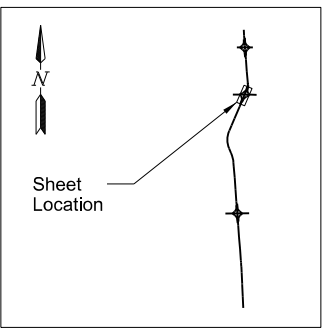

- Removal of Bituminous Surfacing
- Milling Pavement Surface
- Pavement Removal Limits

This document was originally issued and sealed by Chad A. Petersen, Registration Number PE- 4884, on 08/07/17 and the original document is stored at the North Dakota Department of Transportation

I-29 - N of Galchutt Exit to Christine Exit
 Removals - Phase 5
 Christine Interchange Improvements
 Sta 17+60 to 23+81 (EX58ST)

STATE	PROJECT NO.	SECTION NO.	SHEET NO.
ND	IM-8-029(170)033	40	23

SPEC	CODE	BID ITEM	QTY	UNIT
202	0132	REMOVAL OF BITUMINOUS SURFACING		
		Sta 11+08 to 13+11 Lt (Phase 5)	160	SY
		Sta 6+63 to 8+48 Lt (Phase 5)	105	SY

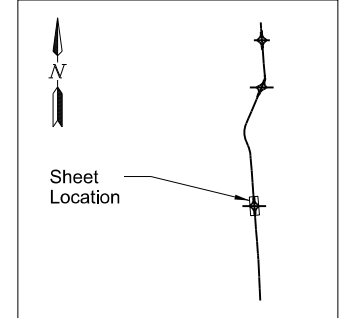
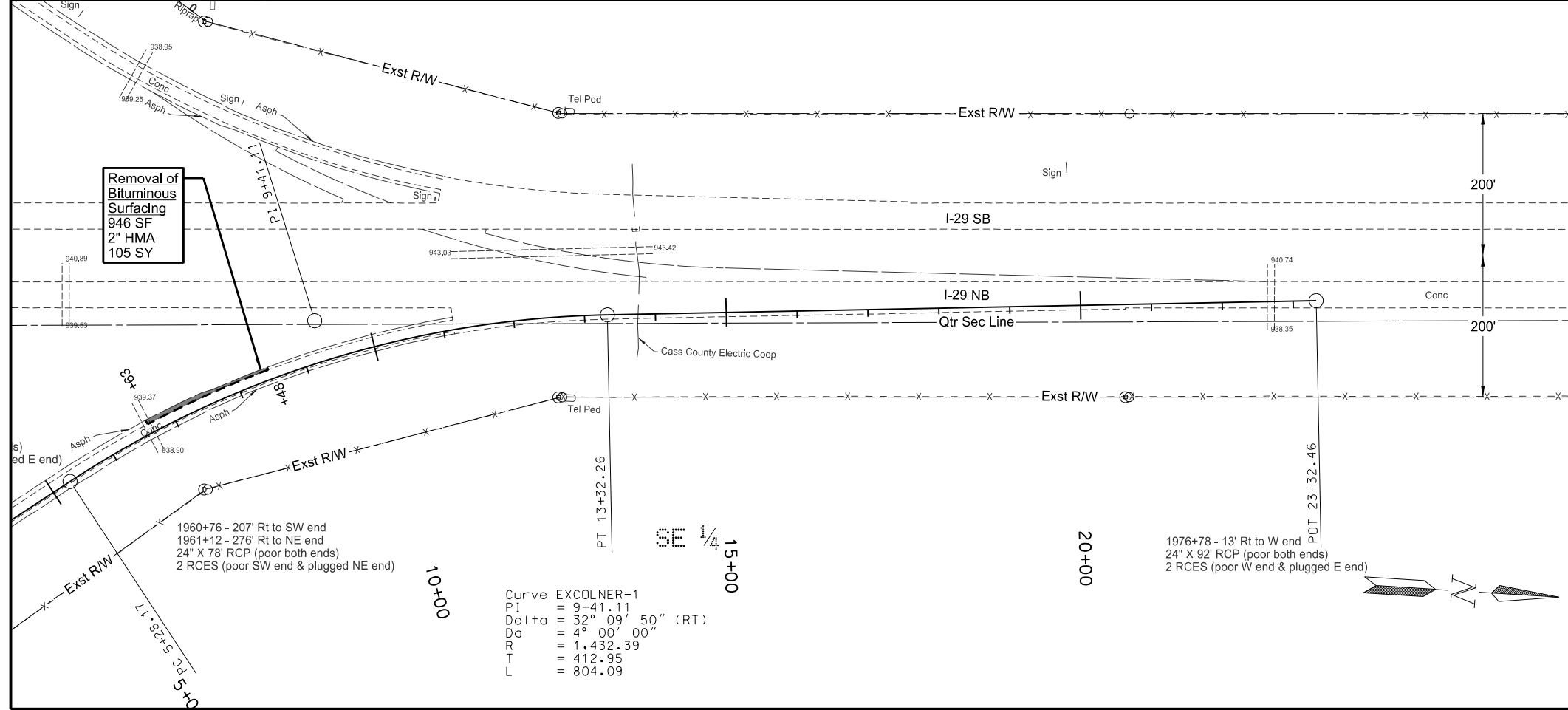
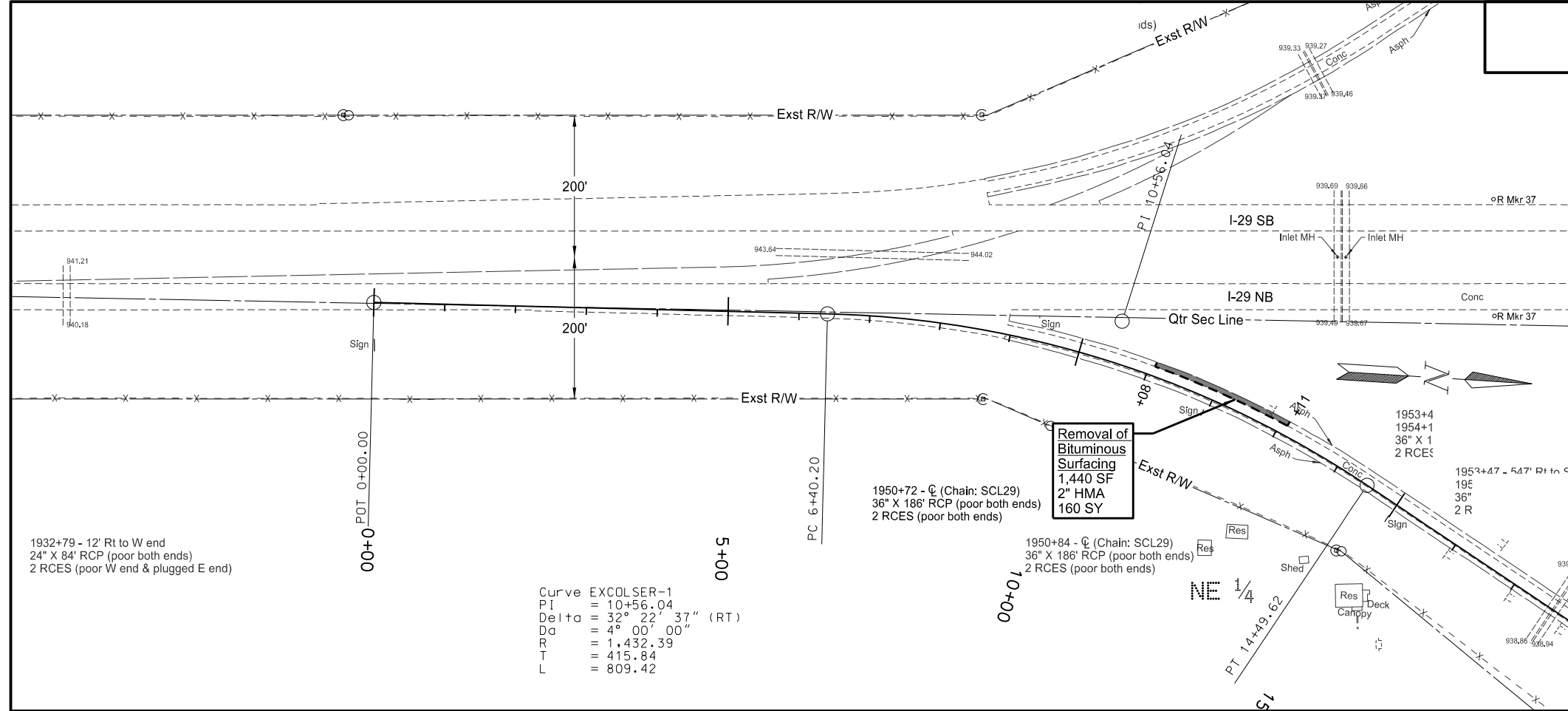

Removal of Bituminous Surfacing
 Pavement Removal Limits

This document was originally issued and sealed by
 Chad A. Petersen,
 Registration Number
 PE- 4884,
 on 08/07/17 and the original document is stored at the
 North Dakota Department
 of Transportation

I-29 - N of Galchutt Exit to Christine Exit
Removals - Phase 5
 Colfax Interchange SE & NE Ramp Connections
 Sta 11+08 to 13+43 (EXCOLSER)
 Sta 6+33 to 8+48 (EXCOLNER)

Sec 3
T-135-N
R-49-W

STATE	PROJECT NO.	SECTION NO.	SHEET NO.
ND	IM-8-029(170)033	40	24

SPEC	CODE	BID ITEM	QTY	UNIT
202	0132	REMOVAL OF BITUMINOUS SURFACING		
		Sta 11+21 to 13+24 Lt (Phase 5)	159	SY
		Sta 4+72 to 6+81 Lt (Phase 5)	141	SY
202	0169	REMOVAL OF END SECTION-ALL TYPES & SIZES		
		Sta 12+03 - 40' Lt (Phase 5)	1	EA
		Sta 6+88 - 42' Lt (Phase 5)	1	EA

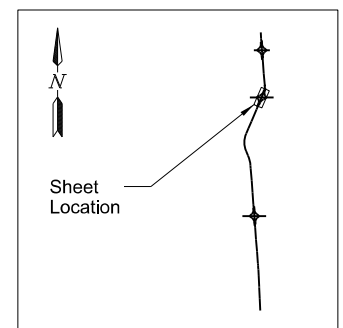
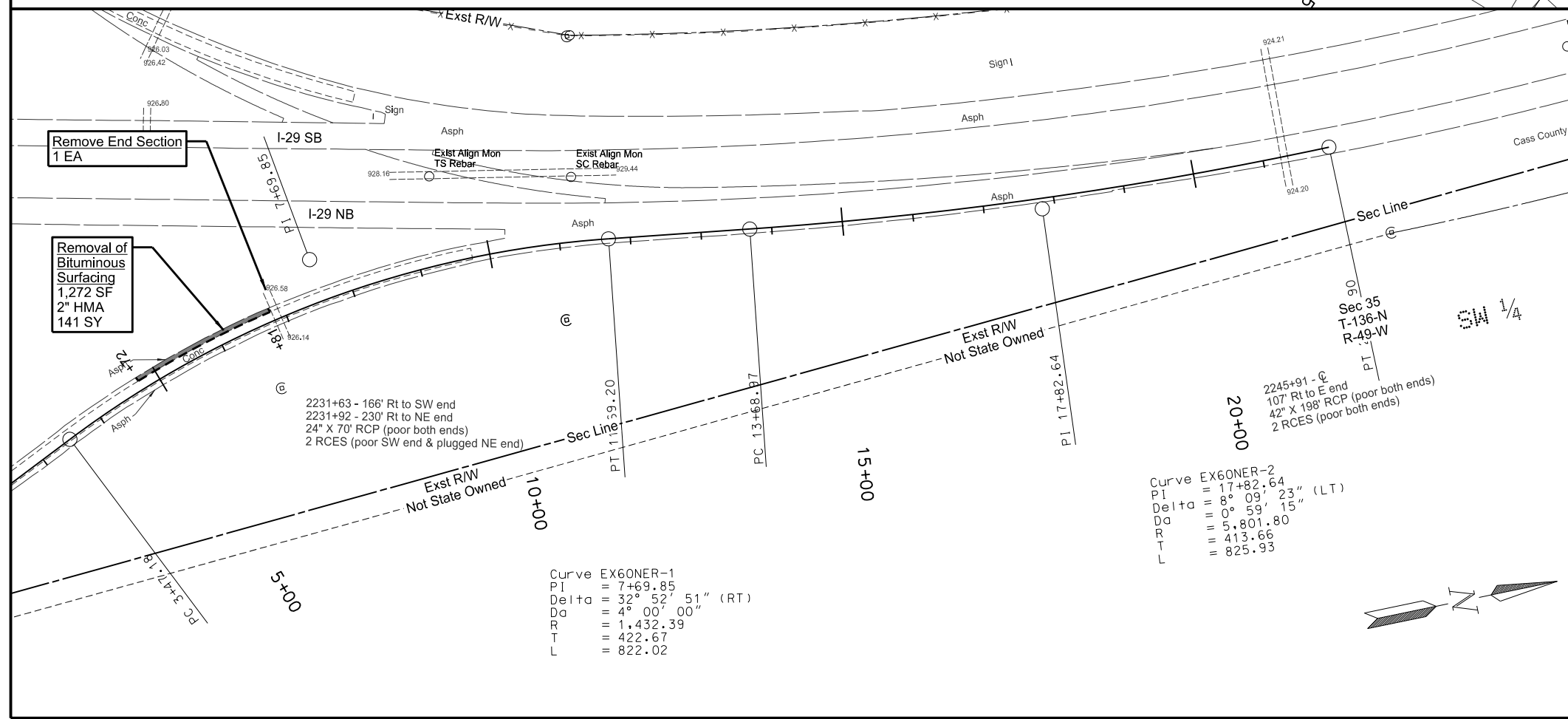
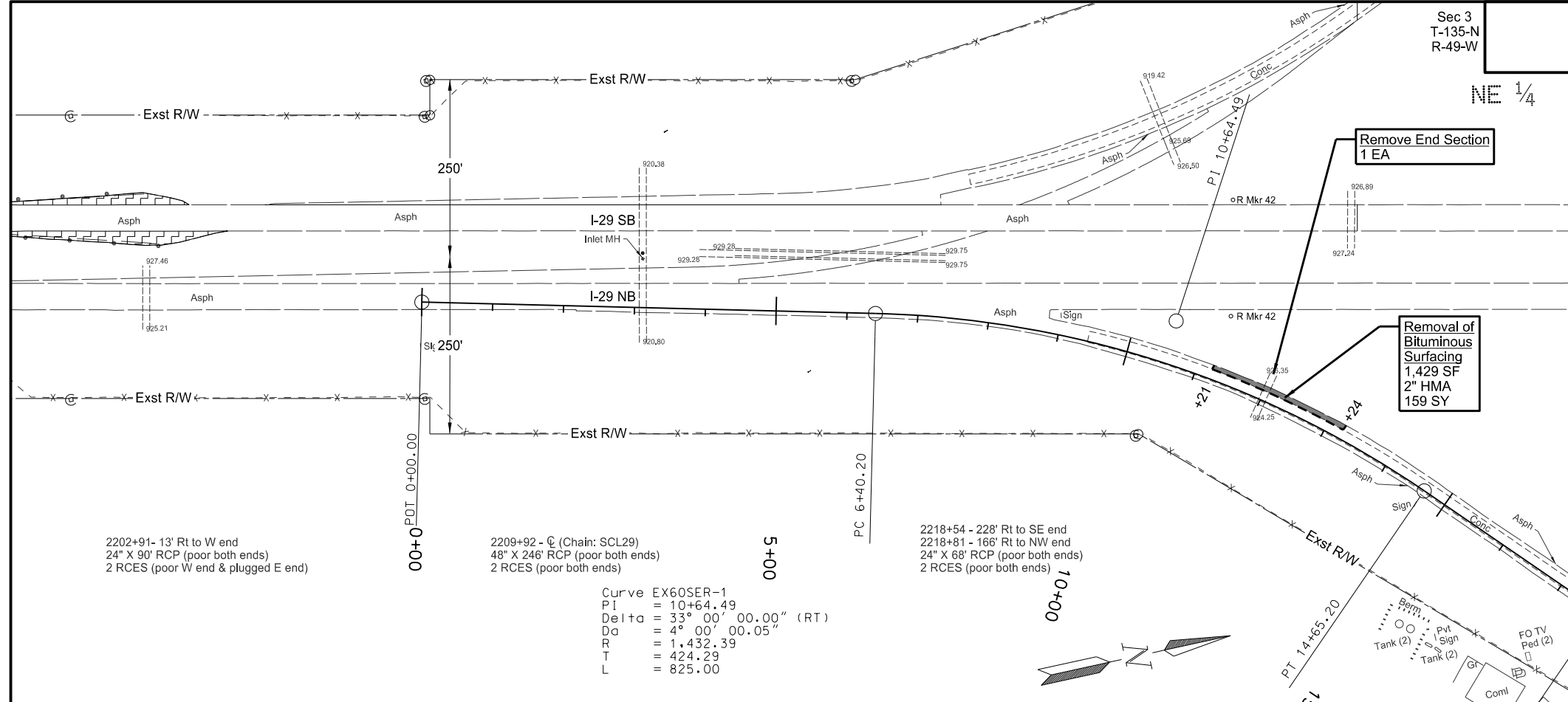

- █ Removal of Bituminous Surfacing
- - - Pavement Removal Limits

This document was originally issued and sealed by
 Chad A. Petersen,
 Registration Number
 PE- 4884,
 on 08/07/17 and the original document is stored at the
 North Dakota Department
 of Transportation

I-29 - N of Galchutt Exit to Christine Exit
 Removals - Phase 5
 Walcott Interchange SE & NE Ramp Connections
 Sta 11+21 to 13+66 (EX60SER)
 Sta 4+48 to 6+81 (EX60NER)

NE 1/4

2312+32 - 13' Lt to E end
24" X 80" RCP (poor both ends)
2 RCES (poor E end & plugged W end)

2325+76 - 229' Lt to NE end
36" X 88" RCP (poor both ends)
2 RCES (poor both ends)

NE 1/4

2324+31 - 13' Lt to E end
24" X 86" RCP (poor both ends)
2 RCES (poor both ends)

STATE

PROJECT NO.

SECTION NO.

SHEET NO.

ND

IM-8-029(170)033

40

25

SPEC	CODE	BID ITEM	QTY	UNIT
202	0132	REMOVAL OF BITUMINOUS SURFACING	94	SY
Sta 11+28 to 13+40 Lt (Phase 5)				

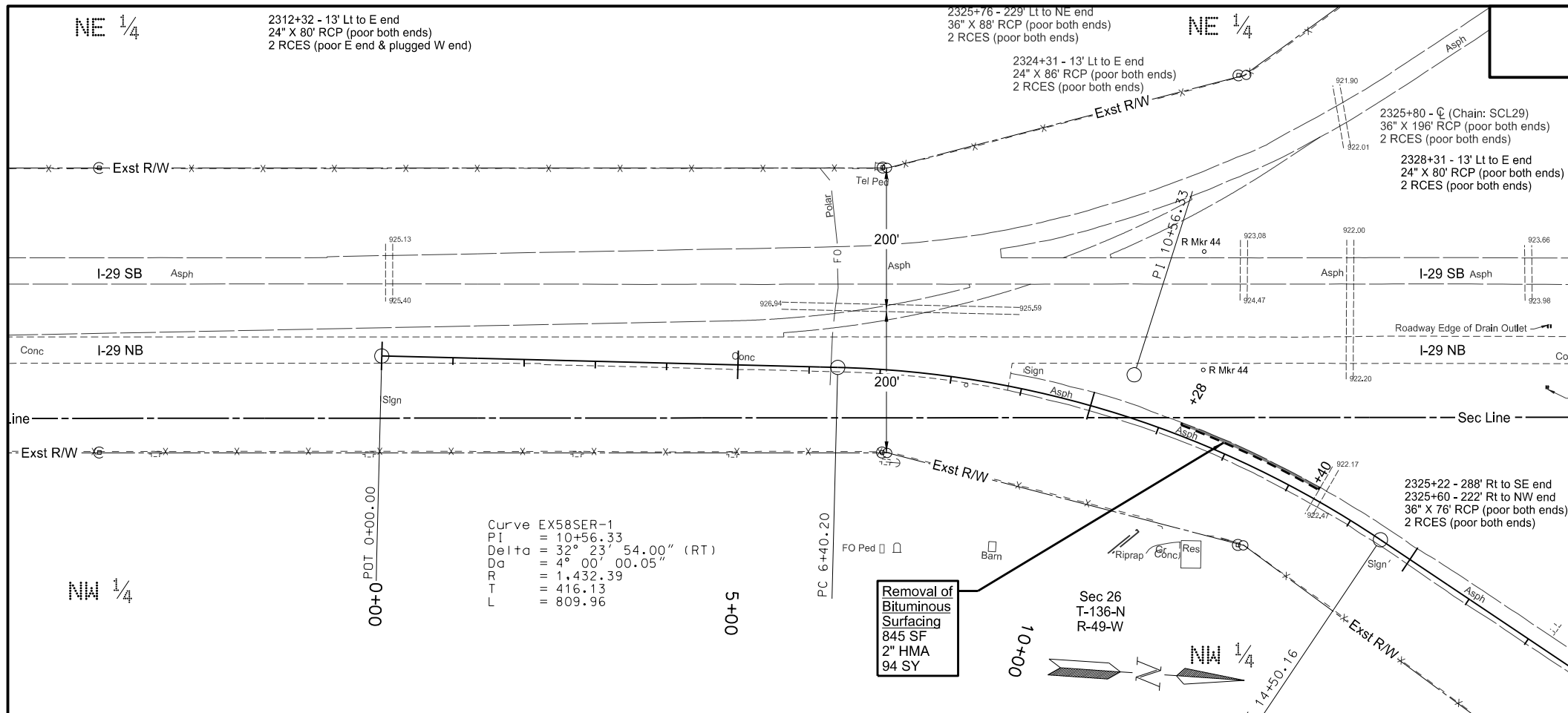

Removal of Bituminous Surfacing
 845 SF
 2" HMA
 94 SY

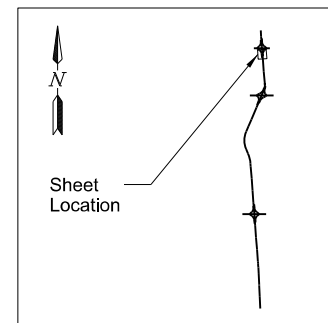

- Removal of Bituminous Surfacing
- Pavement Removal Limits

This document was originally issued and sealed by
 Chad A. Petersen,
 Registration Number
 PE- 4884,
 on 08/07/17 and the original document is stored at the
 North Dakota Department
 of Transportation

I-29 - N of Galchutt Exit to Christine Exit
 Removals - Phase 5
 Christine Interchange SE Ramp Connection
 Sta 11+28 to 13+42 (EX58SER)

STATE	PROJECT NO.	SECTION NO.	SHEET NO.
ND	IM-8-029(170)033	50	1

CULVERT HYDRAULIC DATA FOR IM-8-029(170)033 (A) (B)									
STATION	EXISTING PIPE	PROPOSED PIPE SIZE	DRAINAGE AREAS (ACRES)	50-YEAR DATA				100-YEAR DATA	
				DESIGN DISCHARGE (CFS)	DESIGN HEADWATER (FT)	DESIGN VELOCITY (FPS)	DESIGN STAGE (NAVD 88)	100-YEAR DISCHARGE (CFS)	100-YEAR STAGE (NAVD 88)
1849+74	30"	30"	81.5	32	2.0	5.6	945.85	36	947.82
1902+78	24"	24"	951.4	130	6.2	9.5	947.57	152	947.70
1950+72	36"	36"	961.0	156	6.1	11.2	946.76	183	947.11
1950+84	36"	36"			6.1	10.8			
2058+76	36"	36"	158.5	50	4.1	8.6	938.95	57	939.49
2108+94	24"	24"	4.1	1	0.5	6.5	933.23	1	933.23
2123+92	30"	30"	3.7	2	0.6	7.8	932.10	2	932.10
2138+94	30"	30"	3.8	1	0.4	4.7	931.31	1	931.31
2156+91	24"	24"	4.8	14	2.2	6.2	931.44	15	931.56
2166+93	36"	36"	107.2	21	2.4	6.1	929.37	24	929.56
2173+94	24"	24"	1.4	7	1.4	8.6	929.97	7	929.97
2189+93	24"	24"	3.7	3	0.8	6.6	928.10	3	928.10
2209+92	48"	48"	796.1	93	5.1	9.5	925.94	108	926.83
2219+91	24"	24"	2.2	12	1.9	5.5	929.16	13	929.27
2229+91	24"	24"	5.2	4	1.0	3.7	928.13	5	928.27
2245+90	42"	42"	48.6	35	3.1	6.9	927.29	40	927.54
2254+91	24"	24"	4.2	8	1.5	7.0	927.33	9	927.44
2277+90	24"	24"	69.1	24	3.6	7.8	929.55	27	930.17
2290+30	24"	24"	4.6	6	1.2	4.9	926.85	7	926.98
2299+20	36"	36"	228.0	52	2.8	6.6	927.32	60	927.58
2299+40	36"	36"			2.7	6.5			
2312+32	24"	24"	3.2	5	1.1	4.0	926.51	5	926.51
2324+31	24"	24"	3.0	4	1.4	1.3	925.87	4	925.87
2325+80	36"	36"	133.8	37	4.7	5.2	926.87	41	927.53
STATION	EXISTING PIPE	PROPOSED PIPE SIZE	DRAINAGE AREAS (ACRES)	25-YEAR DATA				100-YEAR DATA	
				DESIGN DISCHARGE (CFS)	DESIGN HEADWATER (FT)	DESIGN VELOCITY (FPS)	DESIGN STAGE (NAVD 88)	100-YEAR DISCHARGE (CFS)	100-YEAR STAGE (NAVD 88)
1950+38	36"	36"	955.7	128	5.2	9.3	944.55	183	946.30
1950+45	36"	36"			5.2	9.4			
1960+77	36"	36"	5.3	19.0	2.8	7.2	942.04	24	942.93
2217+16	30"	30"	7.7	16.0	1.9	13.7	927.63	20	927.93
2230+07	24"	24"	11.0	6.0	1.2	8.1	927.25	8	927.49
2325+69	36"	36"	143.4	37.0	3.3	7.5	925.30	50	926.13

(A) Hydraulic data provided is for smooth-walled type conduits
(B) Culverts were hydraulically analyzed to verify they meet or exceed hydraulic requirements with proposed improvements.

This document was originally issued and sealed by John W. Wirres, Registration Number PE- 4449, on 08/14/17 and the original document is stored at the North Dakota Department of Transportation

I-29 - N or Galchutt Exit to Christine Exit
Culvert Hydraulic Data

ALLOWABLE PIPE LIST															
CHAIN	BEGIN STATION	BEGIN OFFSET	END STATION	END OFFSET	PIPE INSTALLATION PAY ITEM		ALLOWABLE MATERIAL	REQUIRED DIAMETER (IN)	STEEL PIPE COATINGS (TYPE)	STEEL PIPE CORRUGATIONS OR SPIRAL RIBS	MINIMUM THICKNESS (IN)	END SECTION		APPLICABLE BACKFILL DETAIL	
					(IN)	(LF)						BEGIN (EA)	END (EA)		
INTERSTATE 29 SOUTHBOUND															
SCL29	1849+74	99.1' Lt	1849+74	93.1' Lt	30"	Pipe Conc Reinf CL III (Extension)	6	Reinforced Concrete Pipe - Class III (Barrel Length = 6 LF)	30"	-	-	-	FES	-	Section 20 Sheet 6
	1849+74	11.4' Lt			30"	End Sect-Traversable Reinf		Reinforced Concrete Pipe - Class III	30"	-	-	-	TES	-	Section 20 Sheet 6
	1902+78	99.0' Lt	1902+78	93.0' Lt	24"	Pipe Conc Reinf CL III (Extension)	6	Reinforced Concrete Pipe - Class III (Barrel Length = 6 LF)	24"	-	-	-	FES	-	Section 20 Sheet 6
	1902+78	12.4' Lt			24"	End Sect-Traversable Reinf		Reinforced Concrete Pipe - Class III	24"	-	-	-	TES	-	Section 20 Sheet 6
	1950+72	99.9' Lt	1950+72	93.9' Lt	36"	Pipe Conc Reinf CL III (Extension)	6	Reinforced Concrete Pipe - Class III (Barrel Length = 6 LF)	36"	-	-	-	FES	-	Section 20 Sheet 6
	1950+84	99.8' Lt	1950+84	93.8' Lt	36"	Pipe Conc Reinf CL III (Extension)	6	Reinforced Concrete Pipe - Class III (Barrel Length = 6 LF)	36"	-	-	-	FES	-	Section 20 Sheet 6
	2006+91	166.3' Lt	2007+38	166.3' Lt	42"	Pipe Conduit - Approach	48	Reinforced Concrete Pipe - Class III (Barrel Length = 44 LF)	42"	-	-	-	FES	FG	D-714-27M
								Corrugated Steel Pipe	42"	Z, A, P	2	0.064			
								Spiral Rib Steel Pipe	42"	Z, A, P	3/4, 1	0.064			
								High-Density Polyethylene	42"	-	-	-			
	2006+91	156.3' Lt	2007+38	156.3' Lt	42"	Pipe Conduit - Approach	48	Reinforced Concrete Pipe - Class III (Barrel Length = 44 LF)	42"	-	-	-	FES	FG	D-714-27M
								Corrugated Steel Pipe	42"	Z, A, P	2	0.064			
								Spiral Rib Steel Pipe	42"	Z, A, P	3/4, 1	0.064			
								High-Density Polyethylene	42"	-	-	-			
	2006+91	146.4' Lt	2007+38	146.4' Lt	42"	Pipe Conduit - Approach	48	Reinforced Concrete Pipe - Class III (Barrel Length = 44 LF)	42"	-	-	-	FES	FG	D-714-27M
								Corrugated Steel Pipe	42"	Z, A, P	2	0.064			
								Spiral Rib Steel Pipe	42"	Z, A, P	3/4, 1	0.064			
								High-Density Polyethylene	42"	-	-	-			
	2058+76	97.3' Lt	2058+76	91.3' Lt	36"	Pipe Conc Reinf CL III (Extension)	6	Reinforced Concrete Pipe - Class III (Barrel Length = 6 LF)	36"	-	-	-	FES	-	Section 20 Sheet 6
	2058+76	12.5' Lt			36"	End Sect-Traversable Reinf		Reinforced Concrete Pipe - Class III	36"	-	-	-	TES	-	Section 20 Sheet 6
	2108+94	108.2' Lt			24"	End Sect-Conc Reinf		Reinforced Concrete Pipe - Class III	24"	-	-	-	FES	-	Section 20 Sheet 6
	2108+94	13.2' Lt			24"	End Sect-Traversable Reinf		Reinforced Concrete Pipe - Class III	24"	-	-	-	TES	-	Section 20 Sheet 6
	2123+92	128.7' Lt			30"	End Sect-Conc Reinf		Reinforced Concrete Pipe - Class III	30"	-	-	-	FES	-	Section 20 Sheet 6
	2123+92	15.3' Lt			30"	End Sect-Traversable Reinf		Reinforced Concrete Pipe - Class III	30"	-	-	-	TES	-	Section 20 Sheet 6
	2138+94	118.7' Lt			30"	End Sect-Conc Reinf		Reinforced Concrete Pipe - Class III	30"	-	-	-	FES	-	Section 20 Sheet 6
	2138+94	15.6' Lt			30"	End Sect-Traversable Reinf		Reinforced Concrete Pipe - Class III	30"	-	-	-	TES	-	Section 20 Sheet 6
	2156+91	98.5' Lt	2156+91	92.5' Lt	24"	Pipe Conc Reinf CL III (Extension)	6	Reinforced Concrete Pipe - Class III (Barrel Length = 6 LF)	24"	-	-	-	FES	-	Section 20 Sheet 6
	2156+91	11.1' Lt			24"	End Sect-Traversable Reinf		Reinforced Concrete Pipe - Class III	24"	-	-	-	TES	-	Section 20 Sheet 6
2166+93	104.8' Lt			36"	End Sect-Conc Reinf		Reinforced Concrete Pipe - Class III	36"	-	-	-	FES	-	Section 20 Sheet 6	
2173+94	100.6' Lt			24"	End Sect-Conc Reinf		Reinforced Concrete Pipe - Class III	24"	-	-	-	FES	-	Section 20 Sheet 6	
2173+94	7.5' Lt			24"	End Sect-Conc Reinf		Reinforced Concrete Pipe - Class III	24"	-	-	-	FES	-	Section 20 Sheet 6	
2189+93	101.1' Lt			24"	End Sect-Conc Reinf		Reinforced Concrete Pipe - Class III	24"	-	-	-	FES	-	Section 20 Sheet 6	
2189+93	12.2' Lt			24"	End Sect-Traversable Reinf		Reinforced Concrete Pipe - Class III	24"	-	-	-	TES	-	Section 20 Sheet 6	
2209+92	125.5' Lt			48"	End Sect-Conc Reinf		Reinforced Concrete Pipe - Class III	48"	-	-	-	FES	-	Section 20 Sheet 6	

Notes:
1. Standard Drawing backfill details D-714-25, D-714-25M D-714-26, and D-714-26M may be applicable if existing pipe is deemed unsalvageable upon excavation.

This document was originally issued and sealed by John W. Wirres, Registration Number PE- 4449, on 08/07/17 and the original document is stored at the North Dakota Department of Transportation

Coatings: Z = Zinc
A = Aluminum
P = Polymeric (over Zinc or Aluminum)

Corrugations: 2 = 2-2/3"x1/2"
3 = 3"x1"
5 = 5"x1"

Spiral Ribs: 3/4 = 3/4"x3/4"@7-1/2"
1 = 3/4"x1"@11-1/2"

(*) The price bid for "Pipe Conduit" bid items includes end sections. Pipe Extensions shall pay for end sections separately.
FES = Flared End Section
TES = Traversable End Section
FG = Flap Gate

I-29 - N of Galchutt Exit to Christine Exit
Allowable Pipe List

ALLOWABLE PIPE LIST															
CHAIN	BEGIN STATION	BEGIN OFFSET	END STATION	END OFFSET	PIPE INSTALLATION PAY ITEM		ALLOWABLE MATERIAL	REQUIRED DIAMETER (IN)	STEEL PIPE COATINGS (TYPE)	STEEL PIPE CORRUGATIONS OR SPIRAL RIBS	MINIMUM THICKNESS (IN)	END SECTION		APPLICABLE BACKFILL DETAIL	
					(IN)	(LF)						BEGIN (EA)	END (EA)		
INTERSTATE 29 SOUTHBOUND															
SCL29	2219+91	99.1' Lt	2219+91	93.1' Lt	24"	Pipe Conc Reinf CL III (Extension)	6	Reinforced Concrete Pipe - Class III (Barrel Length = 6 LF)	24"	-	-	-	FES	-	Section 20 Sheet 6
	2219+91	11.7' Lt			24"	End Sect-Traversable Reinf		Reinforced Concrete Pipe - Class III	24"	-	-	-	TES	-	Section 20 Sheet 6
	2229+91	98.0' Lt	2229+91	92.0' Lt	24"	Pipe Conc Reinf CL III (Extension)	6	Reinforced Concrete Pipe - Class III (Barrel Length = 6 LF)	24"	-	-	-	FES	-	Section 20 Sheet 6
	2229+91	10.9' Lt			24"	End Sect-Traversable Reinf		Reinforced Concrete Pipe - Class III	24"	-	-	-	TES	-	Section 20 Sheet 6
	2245+90	97.4' Lt	2245+90	91.4' Lt	42"	Pipe Conc Reinf CL III (Extension)	6	Reinforced Concrete Pipe - Class III (Barrel Length = 6 LF)	42"	-	-	-	FES	-	Section 20 Sheet 6
	2254+91	98.7' Lt			24"	End Sect-Conc Reinf		Reinforced Concrete Pipe - Class III	24"	-	-	-	FES	-	Section 20 Sheet 6
	2254+91	11.3' Lt			24"	End Sect-Traversable Reinf		Reinforced Concrete Pipe - Class III	24"	-	-	-	TES	-	Section 20 Sheet 6
	2277+90	97.9' Lt	2277+90	91.9' Lt	24"	Pipe Conc Reinf CL III (Extension)	6	Reinforced Concrete Pipe - Class III (Barrel Length = 6 LF)	24"	-	-	-	FES	-	Section 20 Sheet 6
	2277+90	27.1' Lt	2277+90	11.1' Lt	24"	Remove & Relay (Pipe)	16	Reinforced Concrete Pipe - Class III	24"	-	-	-	-	-	Section 20 Sheet 6
	2277+90	11.1' Lt			24"	End Sect-Traversable Reinf		Reinforced Concrete Pipe - Class III	24"	-	-	-	TES	-	Section 20 Sheet 6
	2290+30	101.0' Lt	2290+30	95.0' Lt	24"	Pipe Conc Reinf CL III (Extension)	6	Reinforced Concrete Pipe - Class III (Barrel Length = 6 LF)	24"	-	-	-	FES	-	Section 20 Sheet 6
	2290+30	12.1' Lt			24"	End Sect-Traversable Reinf		Reinforced Concrete Pipe - Class III	24"	-	-	-	TES	-	Section 20 Sheet 6
	2299+20	99.3' Lt	2299+20	93.3' Lt	36"	Pipe Conc Reinf CL III (Extension)	6	Reinforced Concrete Pipe - Class III (Barrel Length = 6 LF)	36"	-	-	-	FES	-	Section 20 Sheet 6
	2299+40	99.3' Lt	2299+40	93.3' Lt	36"	Pipe Conc Reinf CL III (Extension)	6	Reinforced Concrete Pipe - Class III (Barrel Length = 6 LF)	36"	-	-	-	FES	-	Section 20 Sheet 6
	2312+32	99.6' Lt	2312+32	93.6' Lt	24"	Pipe Conc Reinf CL III (Extension)	6	Reinforced Concrete Pipe - Class III (Barrel Length = 6 LF)	24"	-	-	-	FES	-	Section 20 Sheet 6
	2312+32	12.5' Lt			24"	End Sect-Traversable Reinf		Reinforced Concrete Pipe - Class III	24"	-	-	-	TES	-	Section 20 Sheet 6
	2324+31	98.8' Lt			24"	End Sect-Conc Reinf		Reinforced Concrete Pipe - Class III	24"	-	-	-	FES	-	Section 20 Sheet 6
2324+31	12.7' Lt			24"	End Sect-Traversable Reinf		Reinforced Concrete Pipe - Class III	24"	-	-	-	TES	-	Section 20 Sheet 6	
2325+80	99.1' Lt			36"	End Sect-Conc Reinf		Reinforced Concrete Pipe - Class III	36"	-	-	-	FES	-	Section 20 Sheet 6	
COLFAX INTERCHANGE (RP 37.043)															
EXCOLSWR	17+03	47.0' Rt			36"	End Sect-Conc Reinf		Reinforced Concrete Pipe - Class III	36"	-	-	-	FES	-	Section 20 Sheet 6
	17+04	24.6' Lt			36"	End Sect-Conc Reinf		Reinforced Concrete Pipe - Class III	36"	-	-	-	FES	-	Section 20 Sheet 6
	17+10	47.0' Rt			36"	End Sect-Conc Reinf		Reinforced Concrete Pipe - Class III	36"	-	-	-	FES	-	Section 20 Sheet 6
	17+12	24.5' Lt			36"	End Sect-Conc Reinf		Reinforced Concrete Pipe - Class III	36"	-	-	-	FES	-	Section 20 Sheet 6
EXCOLNWR	6+26	27.6' Lt			24"	End Sect-Conc Reinf		Reinforced Concrete Pipe - Class III	24"	-	-	-	FES	-	Section 20 Sheet 6
	6+26	51.4' Rt			24"	End Sect-Conc Reinf		Reinforced Concrete Pipe - Class III	24"	-	-	-	FES	-	Section 20 Sheet 6

Notes:
1. Standard Drawing backfill details D-714-25, D-714-25M D-714-26, and D-714-26M may be applicable if existing pipe is deemed unsalvageable upon excavation.

This document was originally issued and sealed by John W. Wirres, Registration Number PE- 4449, on 08/07/17 and the original document is stored at the North Dakota Department of Transportation

I-29 - N of Galchutt Exit to Christine Exit
Allowable Pipe List

Coatings: Z = Zinc Corrugations: 2 = 2-2/3"x1/2" Spiral Ribs: 3/4 = 3/4"x3/4"@7-1/2" (*) The price bid for "Pipe Conduit" bid items includes end sections. Pipe Extensions shall pay for end sections separately.
A = Aluminum 3 = 3"x1" 1 = 3/4"x1"@11-1/2" FES = Flared End Section
P = Polymeric (over Zinc or Aluminum) 5 = 5"x1" TES = Traversable End Section
FG = Flap Gate

ALLOWABLE PIPE LIST															
CHAIN	BEGIN STATION	BEGIN OFFSET	END STATION	END OFFSET	PIPE INSTALLATION PAY ITEM		ALLOWABLE MATERIAL	REQUIRED DIAMETER (IN)	STEEL PIPE COATINGS (TYPE)	STEEL PIPE CORRUGATIONS OR SPIRAL RIBS	MINIMUM THICKNESS (IN)	END SECTION		APPLICABLE BACKFILL DETAIL	
					(IN)	(LF)						BEGIN (EA)	END (EA)		
WALCOTT INTERCHANGE (RP 42.117)															
EX60SWR	15+47	39.9' Rt			30"	Remove & Relay (End Section)		Reinforced Concrete Pipe - Class III	30"	-	-	-	Remove & Relay	-	Section 20 Sheet 6
	15+50	55.8' Lt			30"	End Sect-Conc Reinf		Reinforced Concrete Pipe - Class III	30"	-	-	-	FES	-	Section 20 Sheet 6
EX60NWR	8+13	39.7' Rt			24"	Remove & Relay (End Section)		Reinforced Concrete Pipe - Class III	24"	-	-	-	Remove & Relay	-	Section 20 Sheet 6
	8+13	31.6' Lt			24"	End Sect-Conc Reinf		Reinforced Concrete Pipe - Class III	24"	-	-	-	FES	-	Section 20 Sheet 6
CHRISTINE INTERCHANGE (RP 44.126)															
EX58SWR	17+14	49.9' Rt			36"	End Sect-Conc Reinf		Reinforced Concrete Pipe - Class III	36"	-	-	-	FES	-	Section 20 Sheet 6
	17+45	33.9' Lt			36"	End Sect-Conc Reinf		Reinforced Concrete Pipe - Class III	36"	-	-	-	FES	-	Section 20 Sheet 6
RAMP CONNECTIONS															
RC_37_N_SER	108+55	21.7' Rt	110+75	29.6' Lt	12"	Remove and Relay	226	Polyvinyl Chloride (PVC)	12"	-	-	-	-	-	-
RC_37_N_NER	206+33	33.4' Lt	209+14	22.8' Rt	12"	Remove and Relay	287	Polyvinyl Chloride (PVC)	12"	-	-	-	-	-	-
	209+14	22.8' Rt	209+44	25.5' Rt	12"	Pipe PVC	30	Polyvinyl Chloride (PVC)	12"	-	-	-	-	-	-
RC_42_N_SER	305+44	19.3' Rt	305+44	27.2' Rt	48"	Remove & Relay	8	Reinforced Concrete Pipe - Class III	48"	-	-	-	-	-	Section 20 Sheet 8
	305+44	27.2' Rt	305+45	35.2' Rt	48"	Remove & Relay	8	Reinforced Concrete Pipe - Class III (T-Section)	48"	-	-	-	-	-	Section 20 Sheet 8
	305+45	31.2' Rt			48"	Remove & Relay	2	Reinforced Concrete Pipe - Class III (Riser Section)	48"	-	-	-	-	-	Section 20 Sheet 8
	307+88	26.4' Rt	310+78	33.0' Lt	12"	Remove and Relay	296	Polyvinyl Chloride (PVC)	12"	-	-	-	-	-	-
	308+22	25.2' Rt	310+79	30.6' Lt	12"	Remove and Relay	263	Polyvinyl Chloride (PVC)	12"	-	-	-	-	-	-
	314+60	31.0' Lt	314+63	11.3' Lt	24"	Pipe Conc Reinf CL III (Extension)	20	Reinforced Concrete Pipe - Class III (Barrel Length = 20 LF)	24"	-	-	-	-	FES	Section 20 Sheet 6
RC_42_N_NER	403+46	8.8' Lt	403+50	40.5' Lt	24"	Pipe Conc Reinf CL III (Extension)	32	Reinforced Concrete Pipe - Class III (Barrel Length = 32 LF)	24"	-	-	-	-	FES	Section 20 Sheet 6
	406+74	39.3' Lt	409+88	16.5' Rt	12"	Remove & Relay	320	Polyvinyl Chloride (PVC)	12"	-	-	-	-	-	-
	409+88	16.5' Rt	412+25	30.9' Rt	12"	Pipe PVC	238	Polyvinyl Chloride (PVC)	12"	-	-	-	-	-	-
RC_44_N_SER	507+49	28.4' Rt	510+79	30.3' Lt	12"	Remove and Relay	334	Polyvinyl Chloride (PVC)	12"	-	-	-	-	-	-
	510+79	30.3' Lt	511+19	42.8' Lt	12"	Pipe PVC	43	Polyvinyl Chloride (PVC)	12"	-	-	-	-	-	-

Notes:
 1. Standard Drawing backfill details D-714-25, D-714-25M D-714-26, and D-714-26M may be applicable if existing pipe is deemed unsalvageable upon excavation.

Coatings: Z = Zinc Corrugations: 2 = 2-2/3"x1/2" Spiral Ribs: 3/4 = 3/4"x3/4"@7-1/2" (*) The price bid for "Pipe Conduit" bid items includes end sections. Pipe Extensions shall pay for end sections separately.
 A = Aluminum 3 = 3"x1" 1 = 3/4"x1"@11-1/2" FES = Flared End Section
 P = Polymeric (over Zinc or Aluminum) 5 = 5"x1" TES = Traversable End Section
 FG = Flap Gate

This document was originally issued and sealed by John W. Wirres, Registration Number PE- 4449, on 08/07/17 and the original document is stored at the North Dakota Department of Transportation

I-29 - N of Galchutt Exit to Christine Exit
 Allowable Pipe List

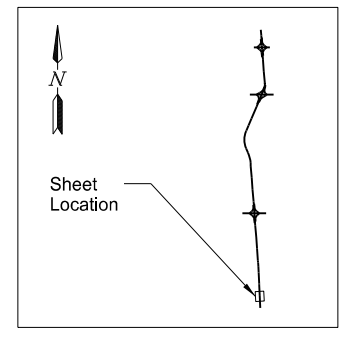
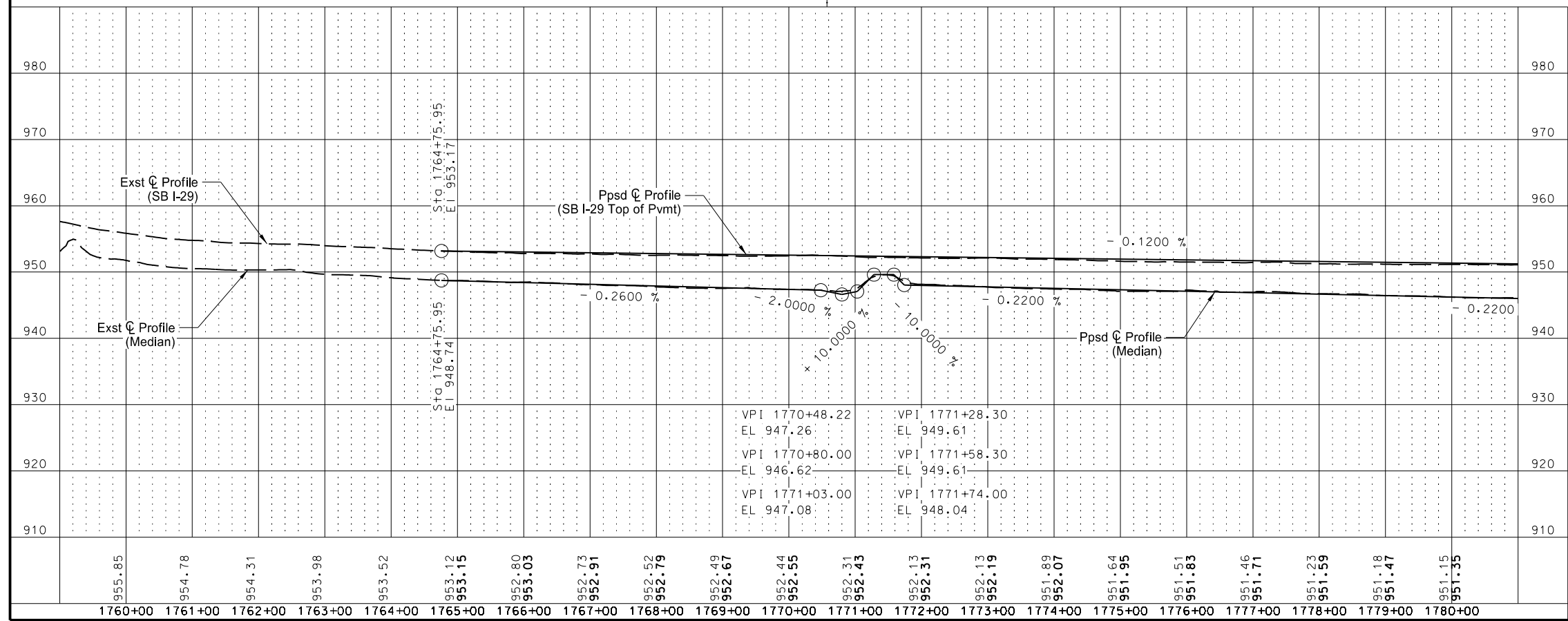
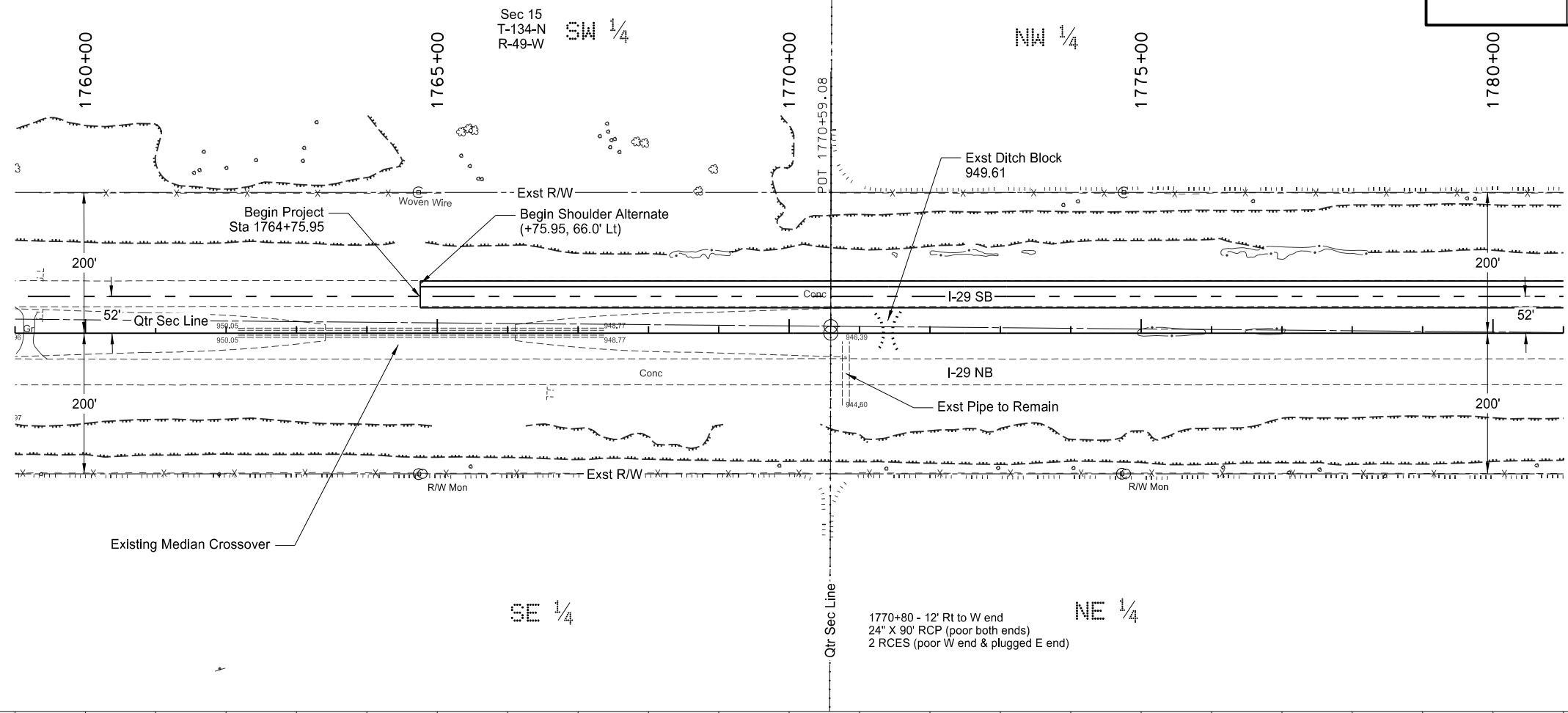

This document was originally issued and sealed by Jonathan D. Bach, Registration Number PE- 9797, on 08/07/17 and the original document is stored at the North Dakota Department of Transportation

I-29 - N of Galchutt Exit to Christine Exit
Plan & Profile
Interstate 29
Sta 1760+00 to 1780+00 (SCL29)

STATE	PROJECT NO.	SECTION NO.	SHEET NO.
ND	IM-8-029(170)033	60	2

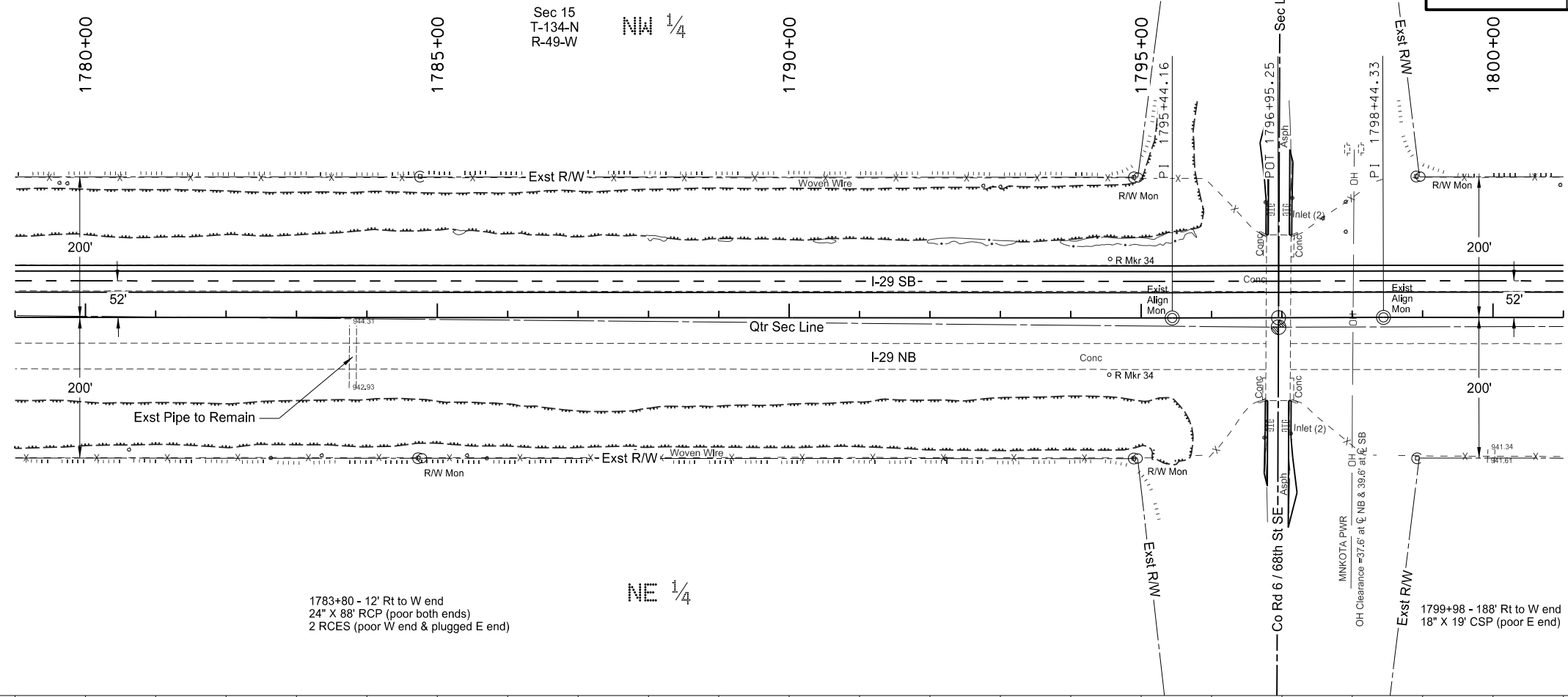

1783+80 - 12' Rt to W end
 24" X 88' RCP (poor both ends)
 2 RCES (poor W end & plugged E end)

NE 1/4

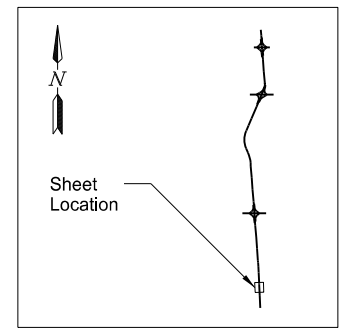
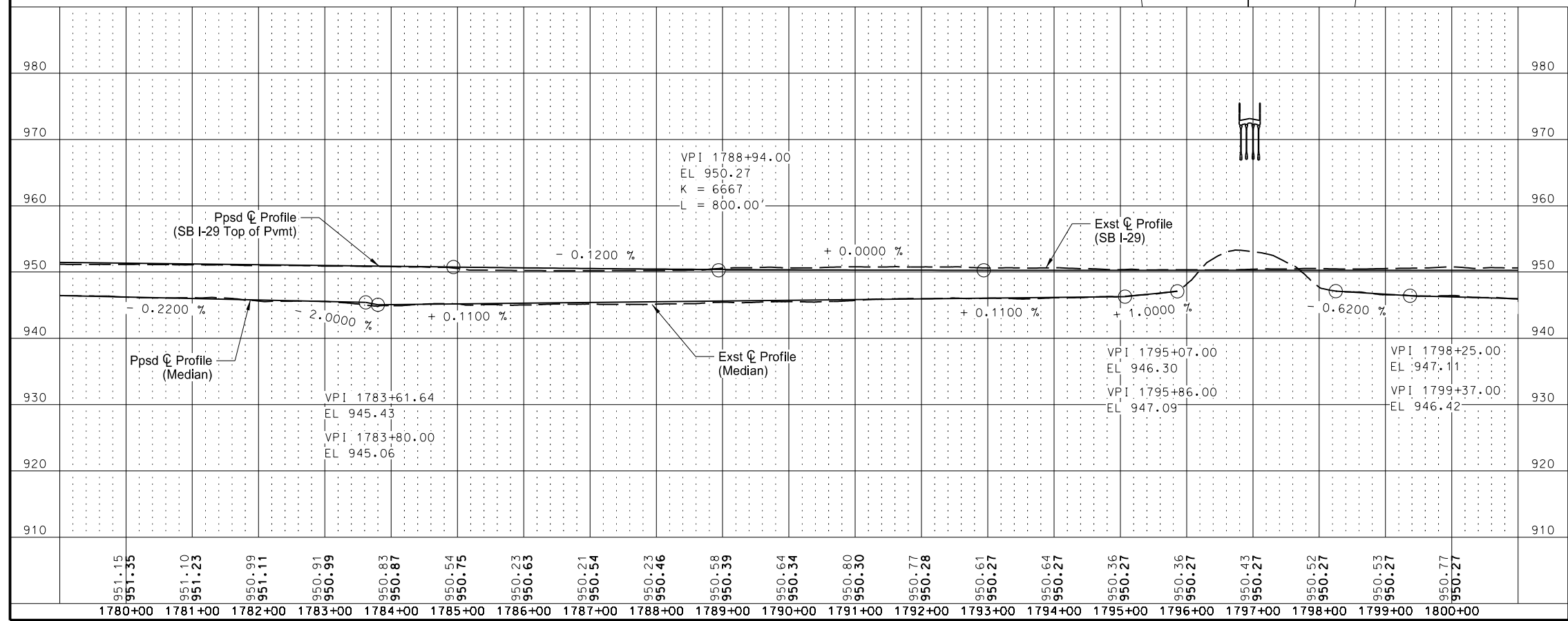

This document was originally issued and sealed by Jonathan D. Bach, Registration Number PE- 9797, on 08/07/17 and the original document is stored at the North Dakota Department of Transportation

I-29 - N of Galchutt Exit to Christine Exit
 Plan & Profile
 Interstate 29
 Sta 1780+00 to 1800+00 (SCL29)

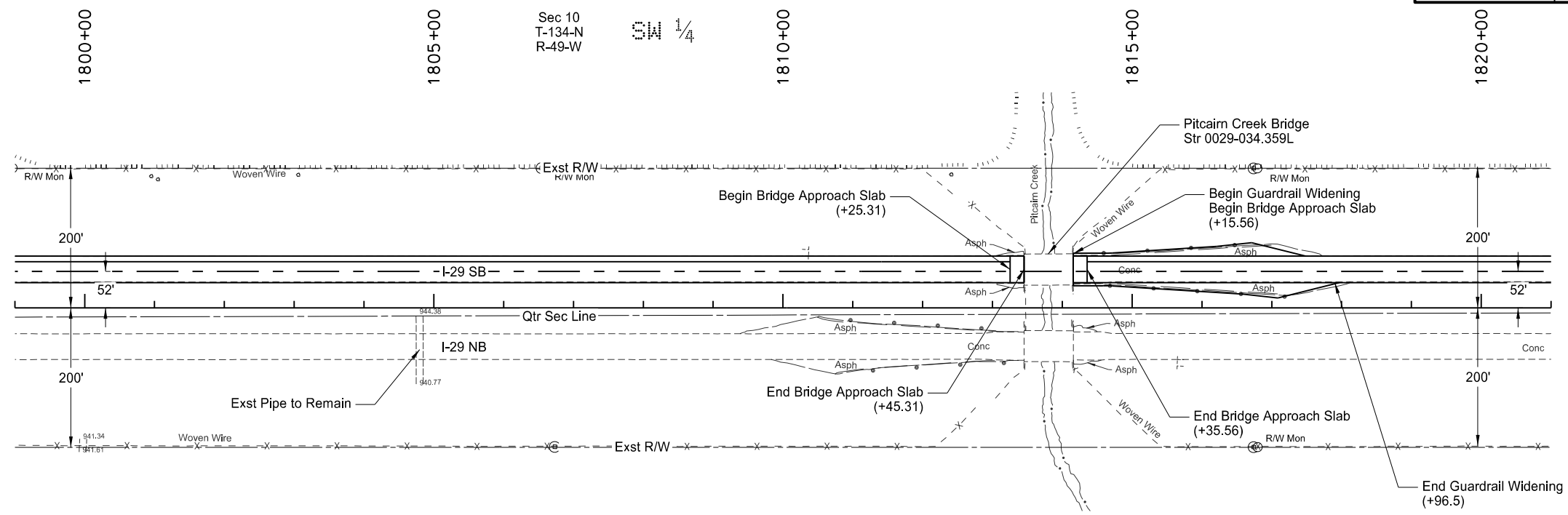

1799+98 - 188' Rt to W end
18" X 19' CSP (poor E end)

1804+80 - 11' Rt to W end
30" X 98' RCP (poor both ends)
2 RCES (poor W end & plugged E end)

SE 1/4

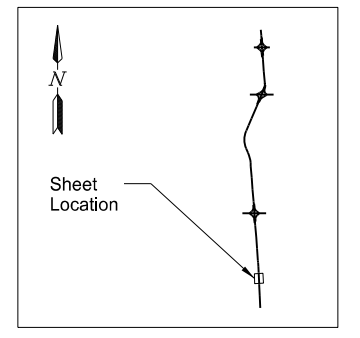
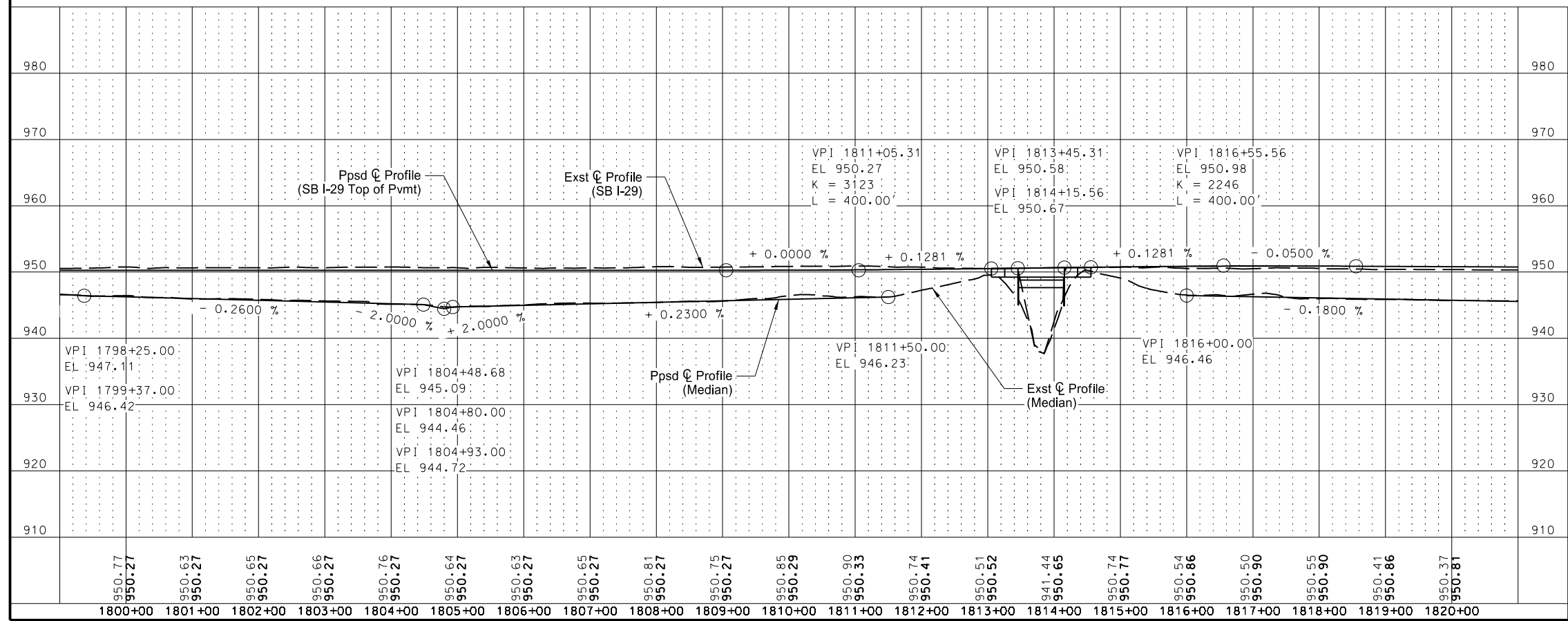

This document was originally issued and sealed by Jonathan D. Bach, Registration Number PE- 9797, on 08/07/17 and the original document is stored at the North Dakota Department of Transportation

I-29 - N of Galchutt Exit to Christine Exit
Plan & Profile
Interstate 29
Sta 1800+00 to 1820+00 (SCL29)

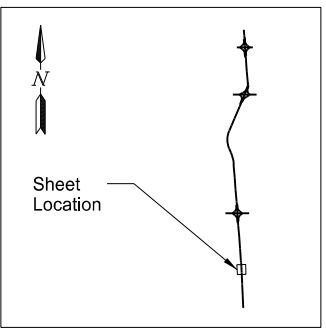
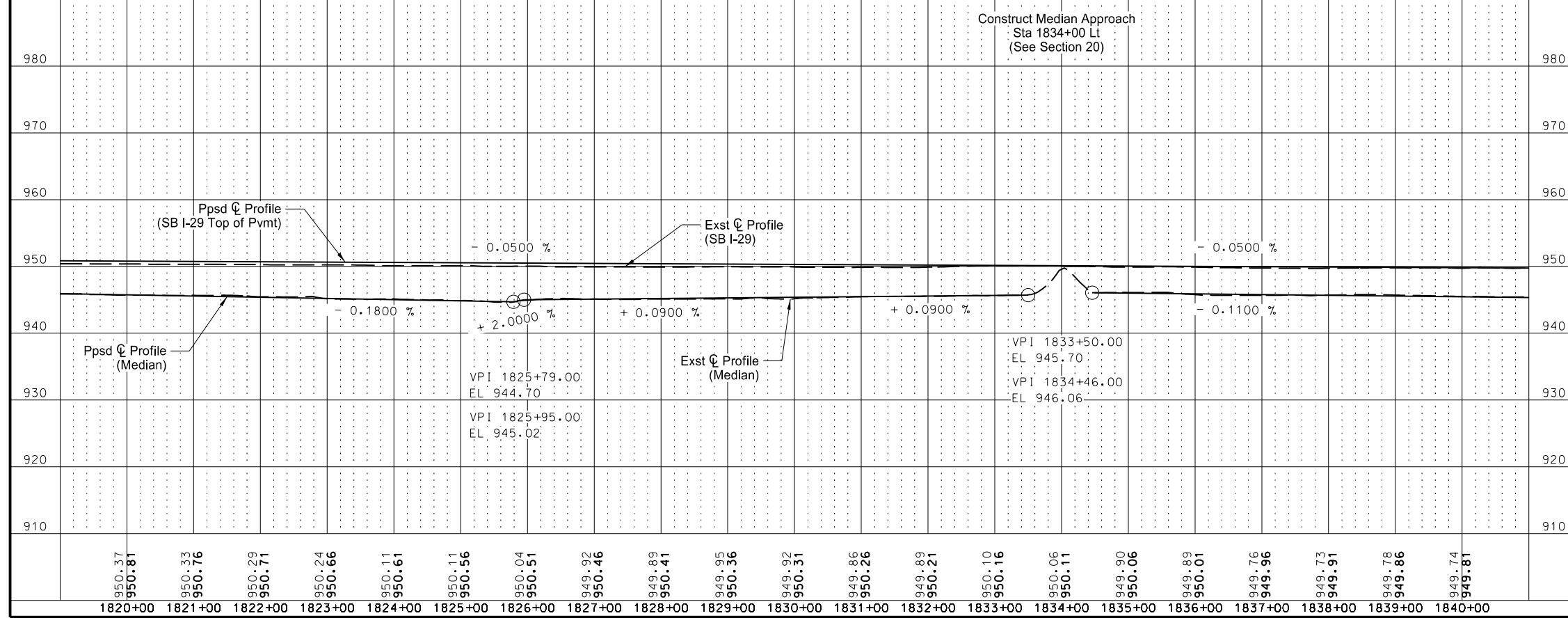
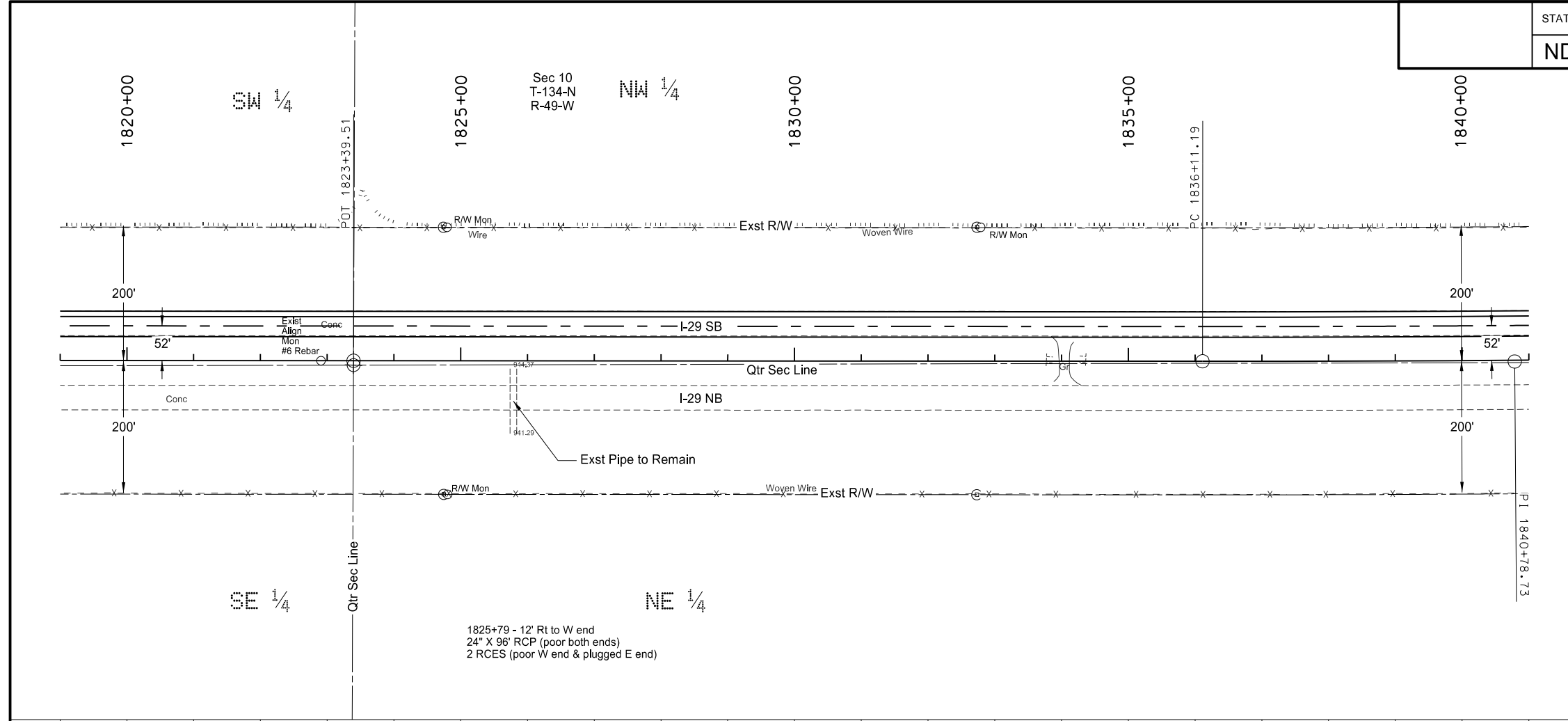

This document was originally issued and sealed by Jonathan D. Bach, Registration Number PE- 9797, on 08/07/17 and the original document is stored at the North Dakota Department of Transportation

I-29 - N of Galchutt Exit to Christine Exit
Plan & Profile
Interstate 29
Sta 1820+00 to 1840+00 (SCL29)

STATE	PROJECT NO.	SECTION NO.	SHEET NO.
ND	IM-8-029(170)033	60	5

SPEC	CODE	BID ITEM	QTY	UNIT
714	0820	PIPE CONC REINF 30IN CL III Sta 1849+74 ~ 93.1' Lt to Sta 1849+74 ~ 99.1' Lt	6	LF
714	3030	END SECT-CONC REINF 30IN Sta 1849+74 ~ 99.1' Lt	1	EA
714	3033	END SECT-TRAVERSABLE REINF. CONC.30IN Sta 1849+74 ~ 11.4' Lt	1	EA

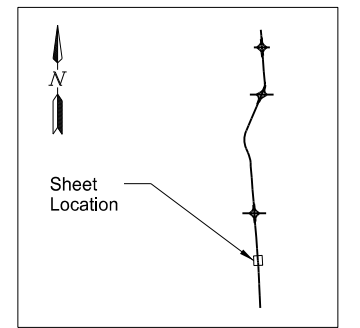
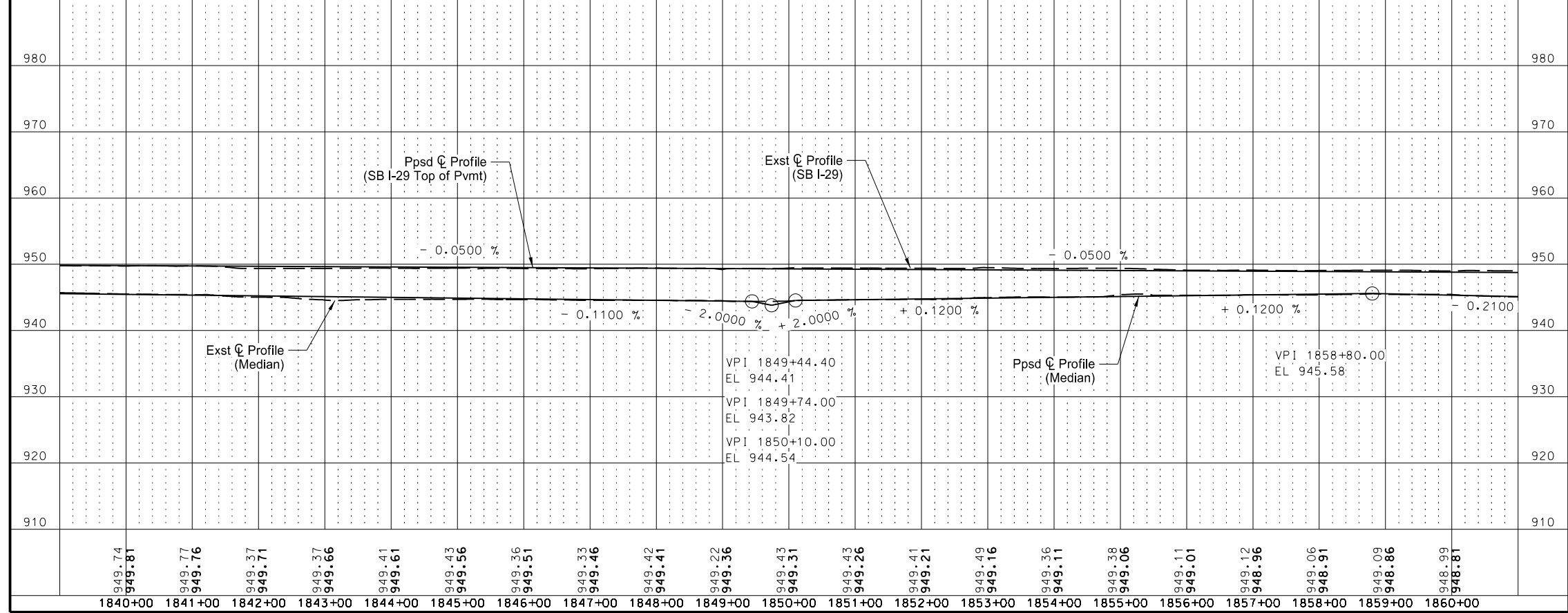
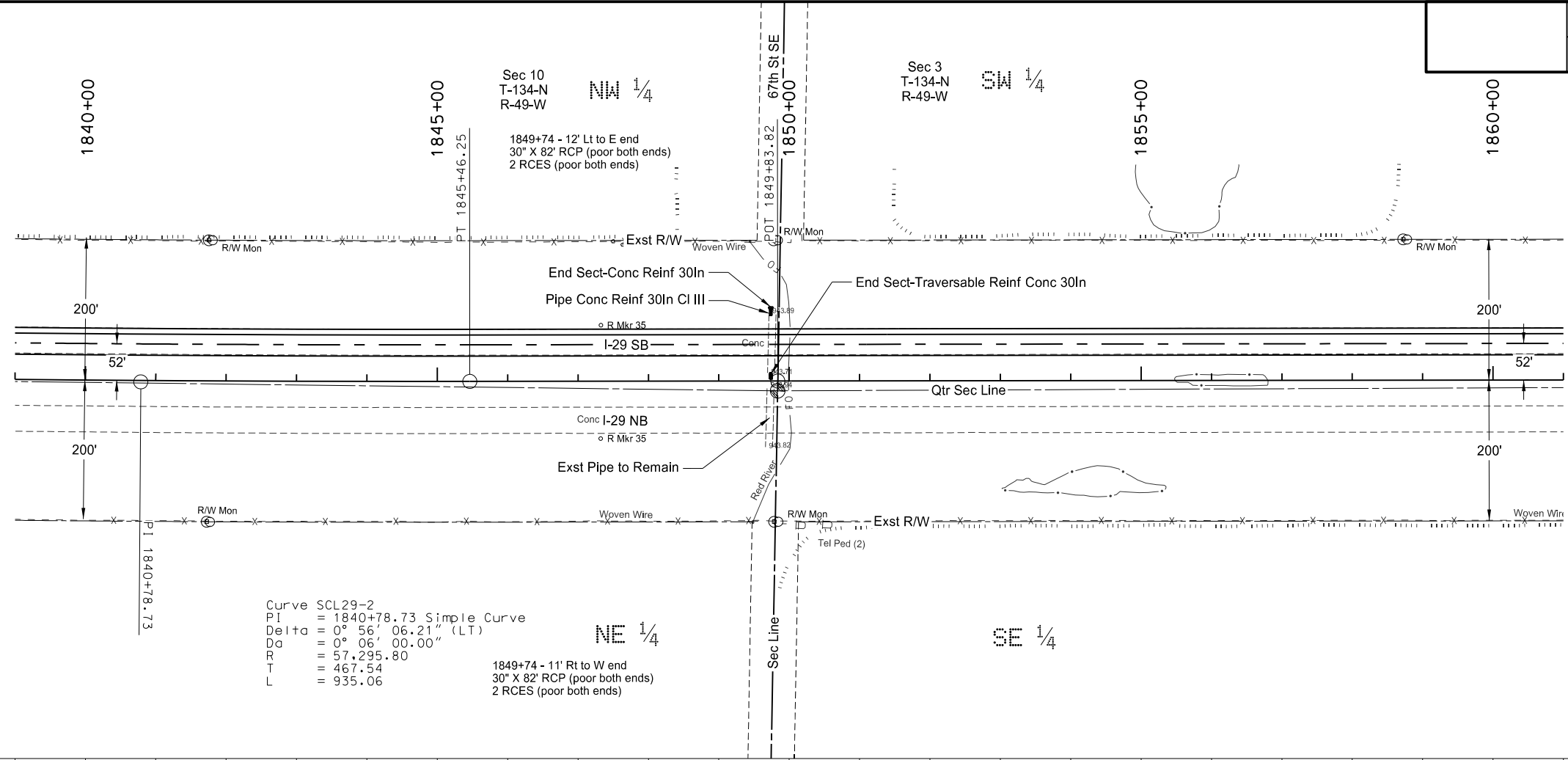

This document was originally issued and sealed by Jonathan D. Bach, Registration Number PE- 9797, on 08/07/17 and the original document is stored at the North Dakota Department of Transportation

I-29 - N of Galchutt Exit to Christine Exit
Plan & Profile
Interstate 29
Sta 1840+00 to 1860+00 (SCL29)

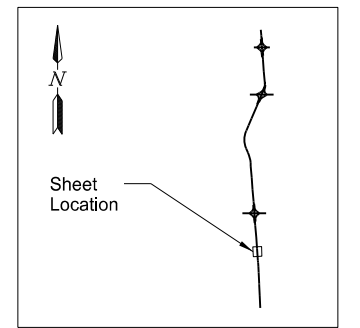
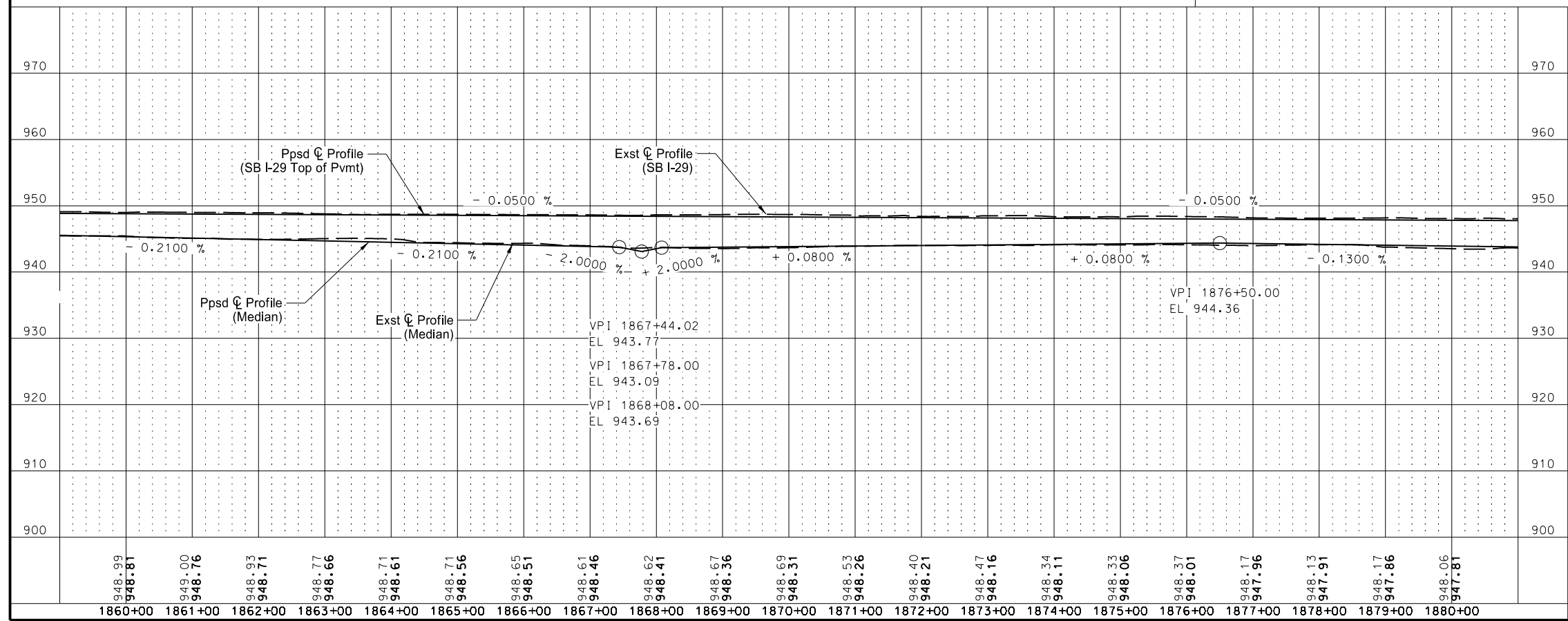
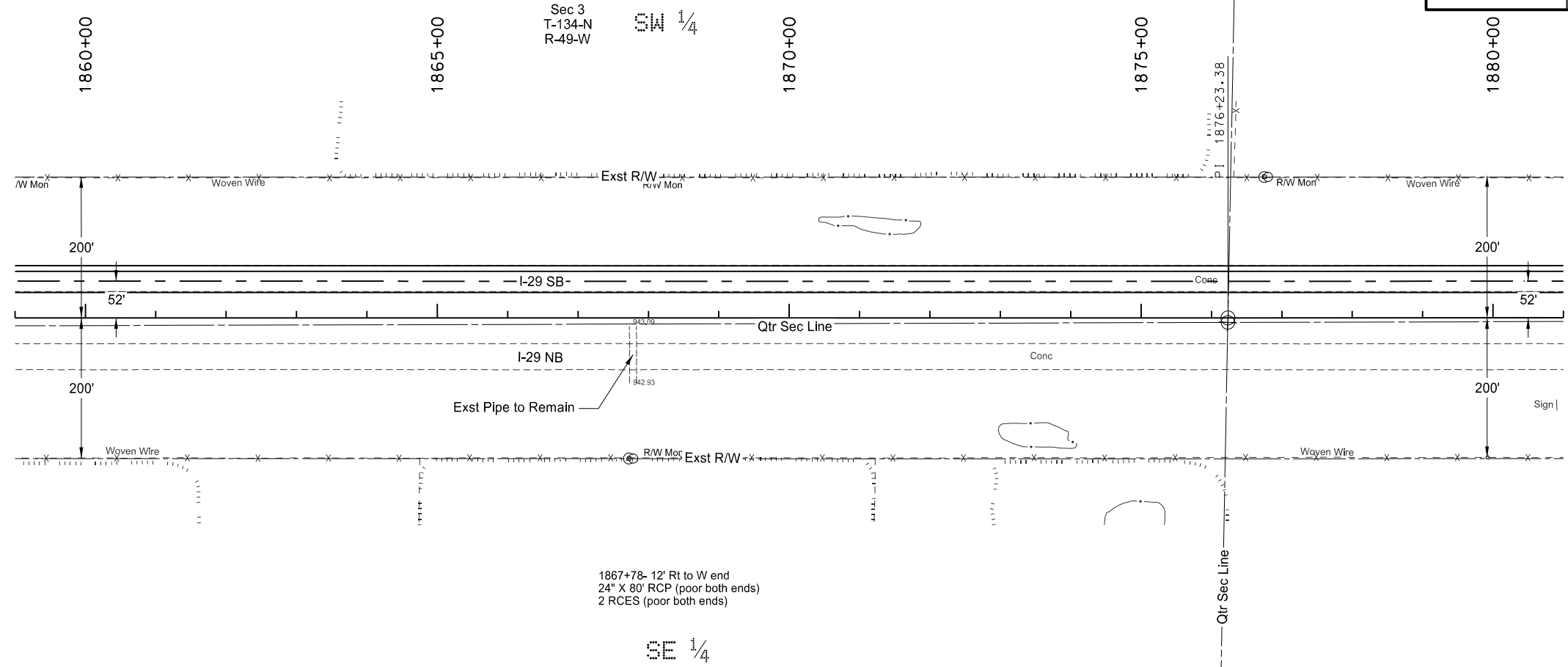

This document was originally issued and sealed by Jonathan D. Bach, Registration Number PE- 9797, on 08/07/17 and the original document is stored at the North Dakota Department of Transportation

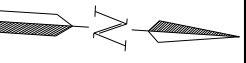

I-29 - N of Galchutt Exit to Christine Exit
Plan & Profile
Interstate 29
Sta 1860+00 to 1880+00 (SCL29)

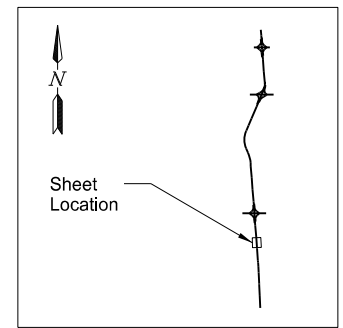
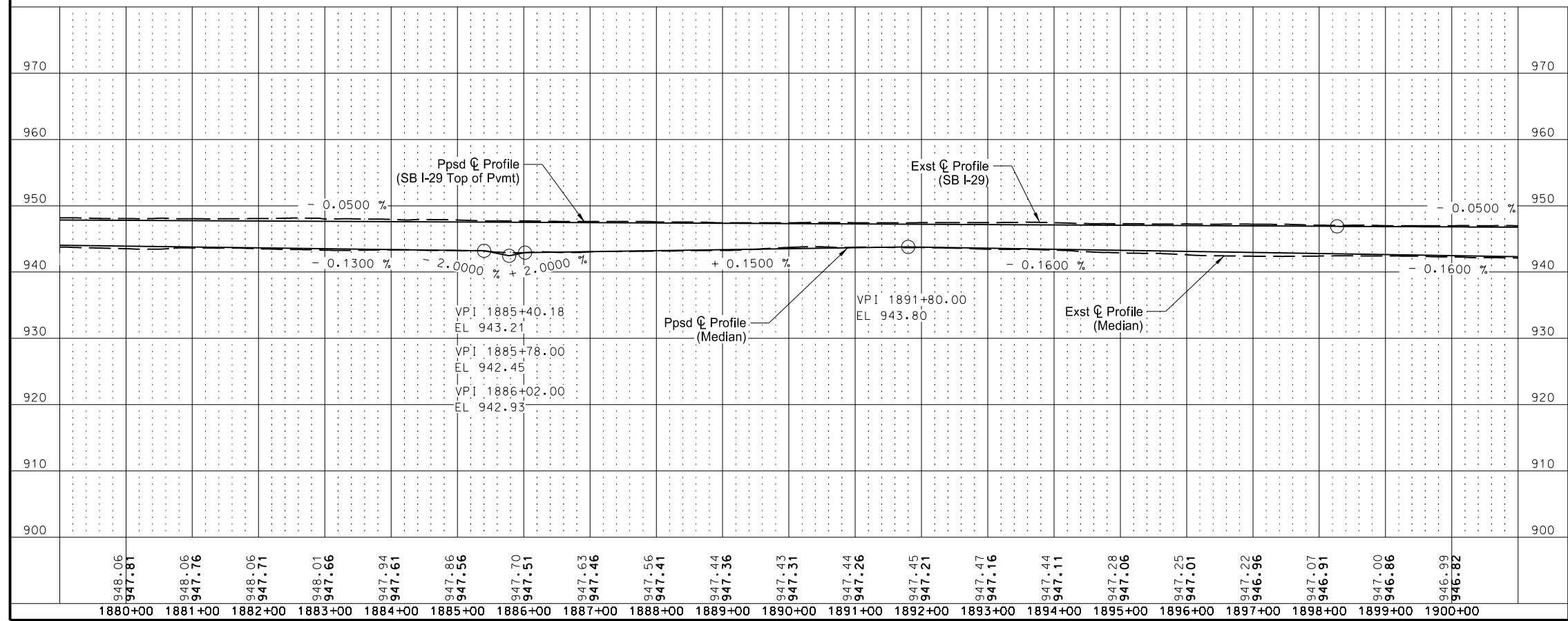
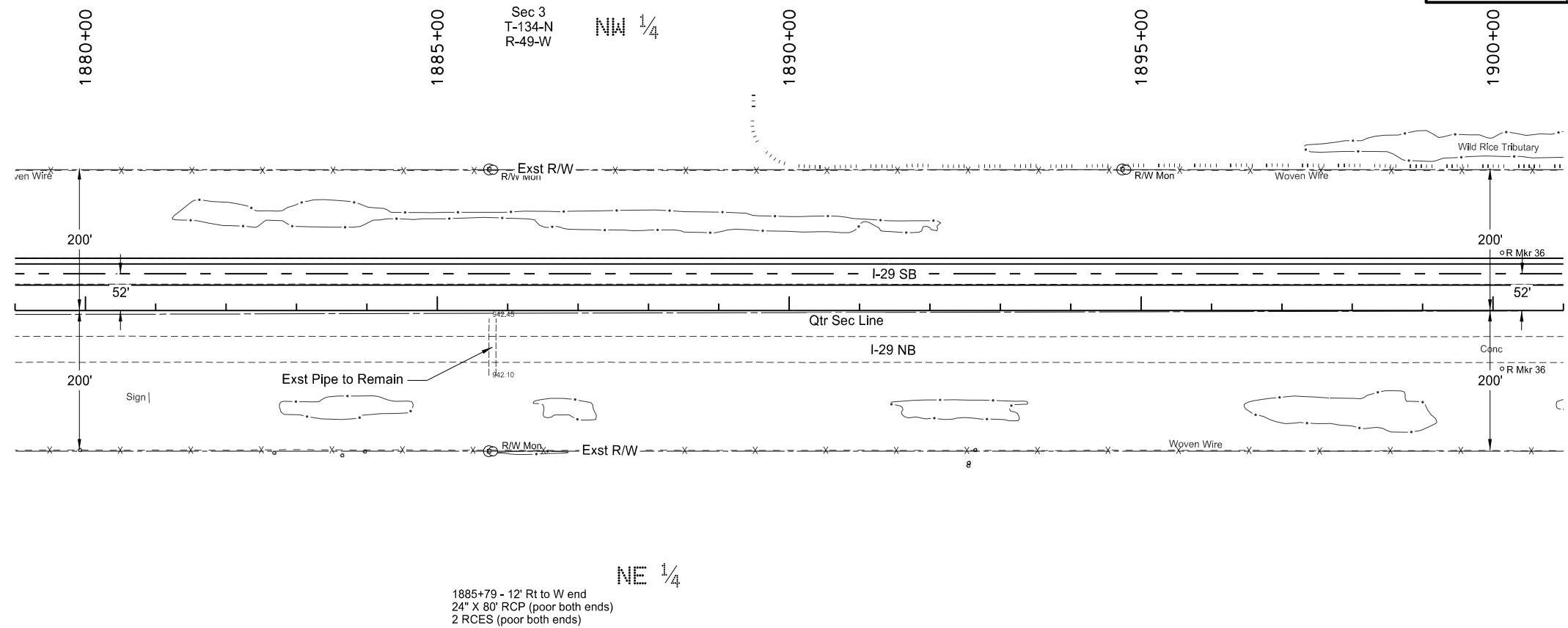

This document was originally issued and sealed by Jonathan D. Bach, Registration Number PE- 9797, on 08/07/17 and the original document is stored at the North Dakota Department of Transportation

I-29 - N of Galchutt Exit to Christine Exit
Plan & Profile
Interstate 29
Sta 1880+00 to 1900+00 (SCL29)

STATE	PROJECT NO.	SECTION NO.	SHEET NO.
ND	IM-8-029(170)033	60	8

SPEC	CODE	BID ITEM	QTY	UNIT
714	0615	PIPE CONC REINF 24IN CL III Sta 1902+78 ~ 93.0' Lt to Sta 1902+78 ~ 99.0' Lt	6	LF
714	3020	END SECT-CONC REINF 24IN Sta 1902+78 ~ 99.0' Lt	1	EA
714	3023	END SECT-TRAVERSABLE REINF. CONC.24IN Sta 1902+78 ~ 12.4' Lt	1	EA

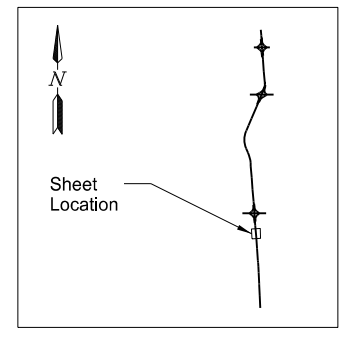
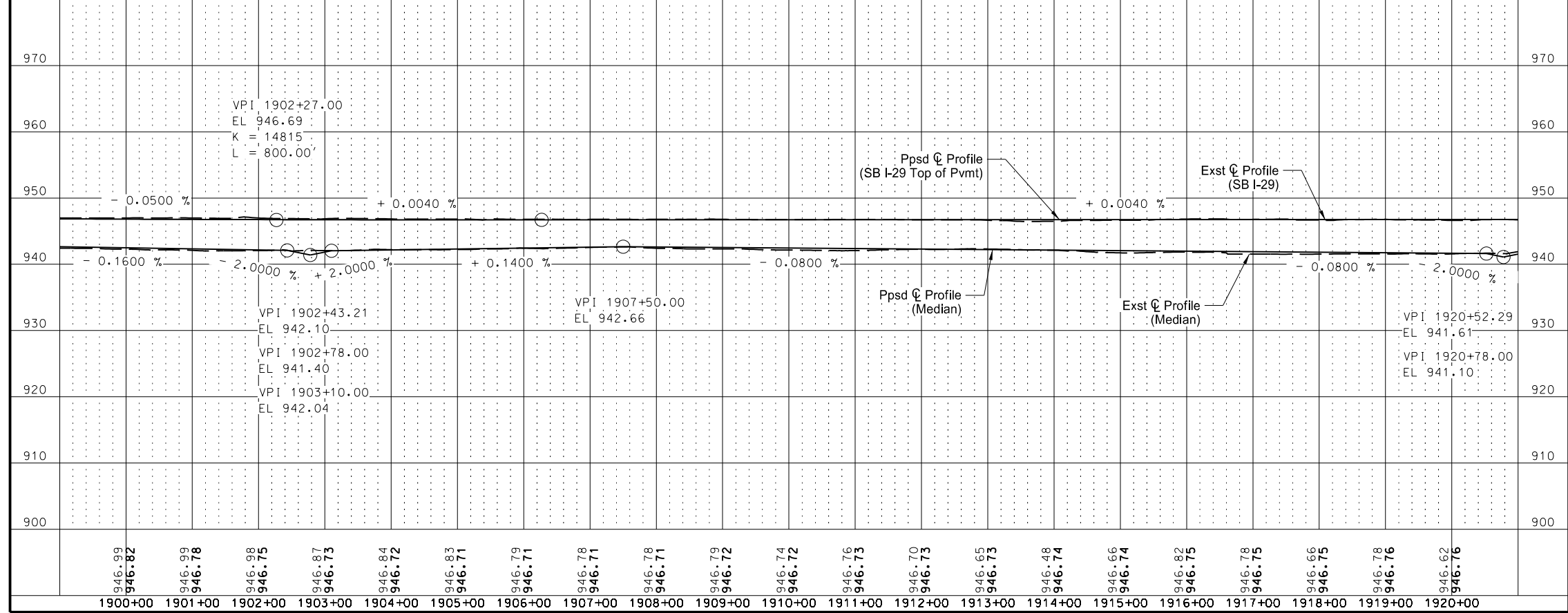
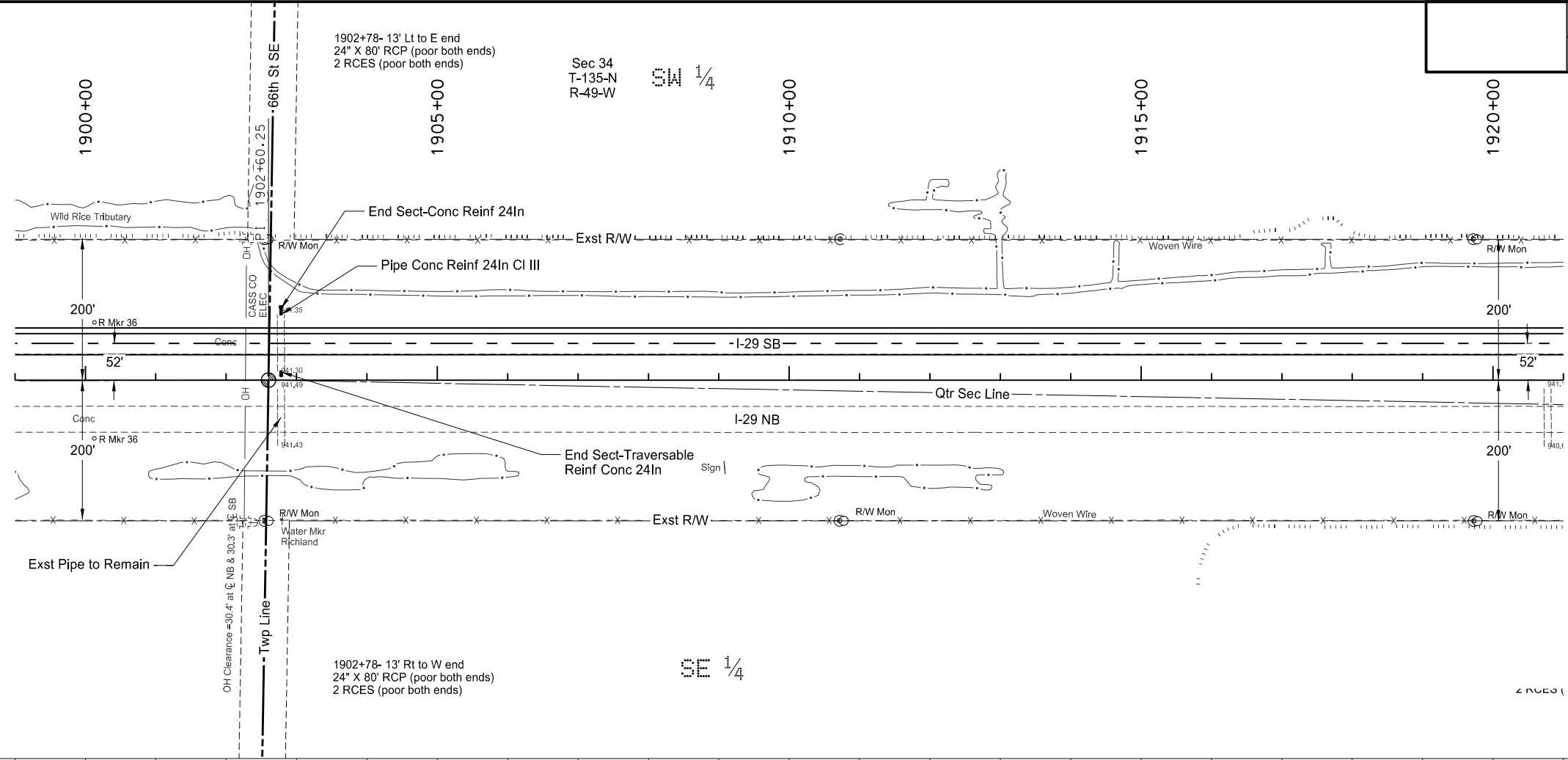

This document was originally issued and sealed by Jonathan D. Bach, Registration Number PE- 9797, on 08/07/17 and the original document is stored at the North Dakota Department of Transportation

I-29 - N of Galchutt Exit to Christine Exit
Plan & Profile
Interstate 29
Sta 1900+00 to 1920+00 (SCL29)

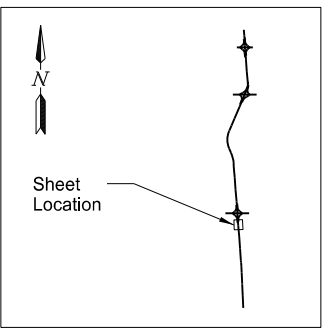
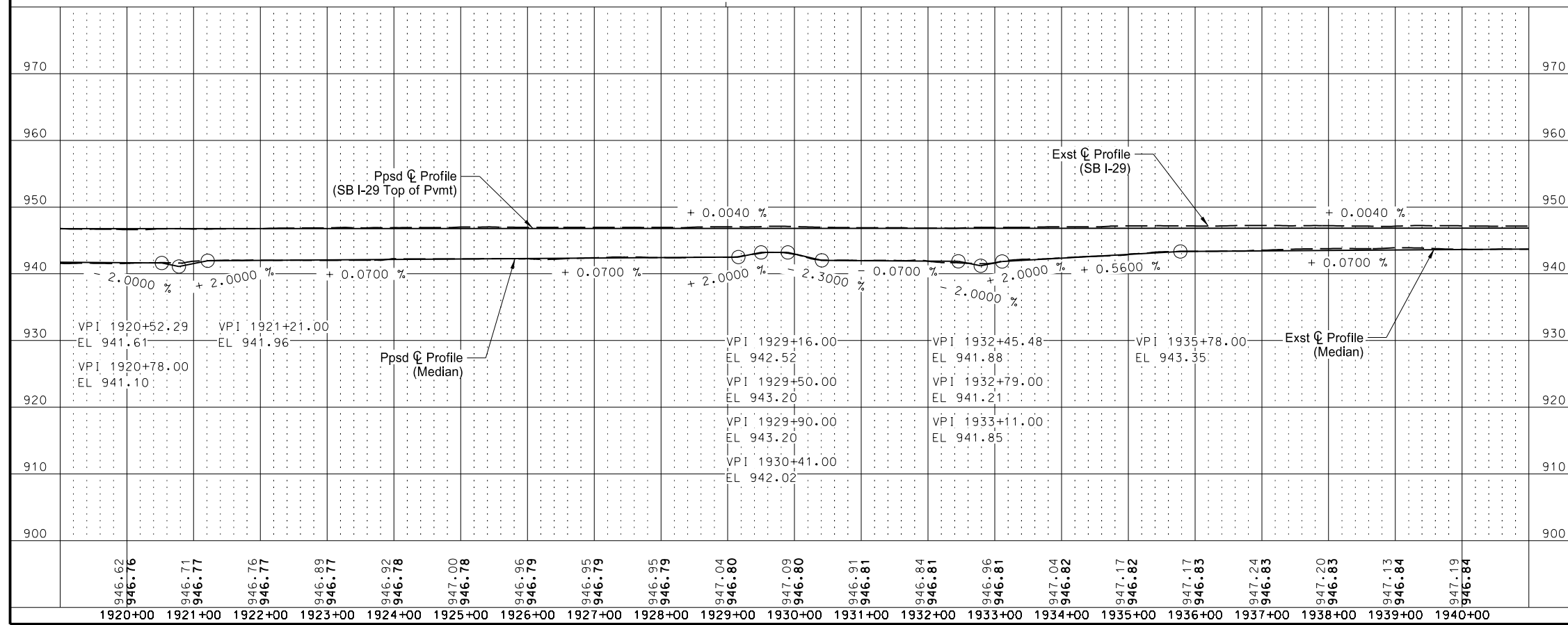
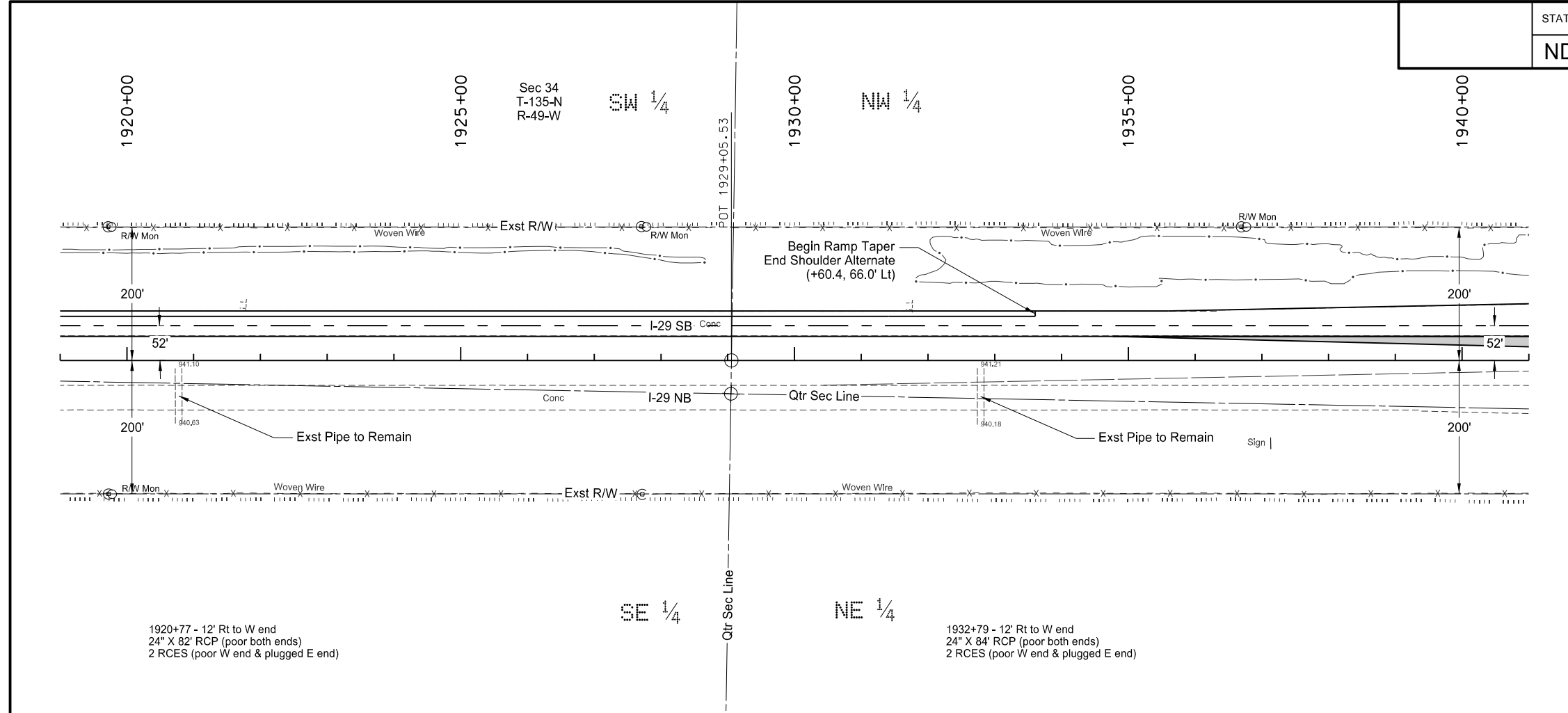

This document was originally issued and sealed by Jonathan D. Bach, Registration Number PE- 9797, on 08/07/17 and the original document is stored at the North Dakota Department of Transportation

I-29 - N of Galchutt Exit to Christine Exit
 Plan & Profile
 Interstate 29
 Sta 1920+00 to 1940+00 (SCL29)

STATE	PROJECT NO.	SECTION NO.	SHEET NO.
ND	IM-8-029(170)033	60	10

SPEC	CODE	BID ITEM	QTY	UNIT
714	0905	PIPE CONC REINF 36IN CL III		
		Sta 1950+72 ~ 93.9' Lt to Sta 1950+72 ~ 99.9' Lt	6	LF
		Sta 1950+84 ~ 93.8' Lt to Sta 1950+84 ~ 99.8' Lt	6	LF
714	3035	END SECT-CONC REINF 36IN		
		Sta 1950+72 ~ 93.9' Lt	1	EA
		Sta 1950+84 ~ 93.8' Lt	1	EA

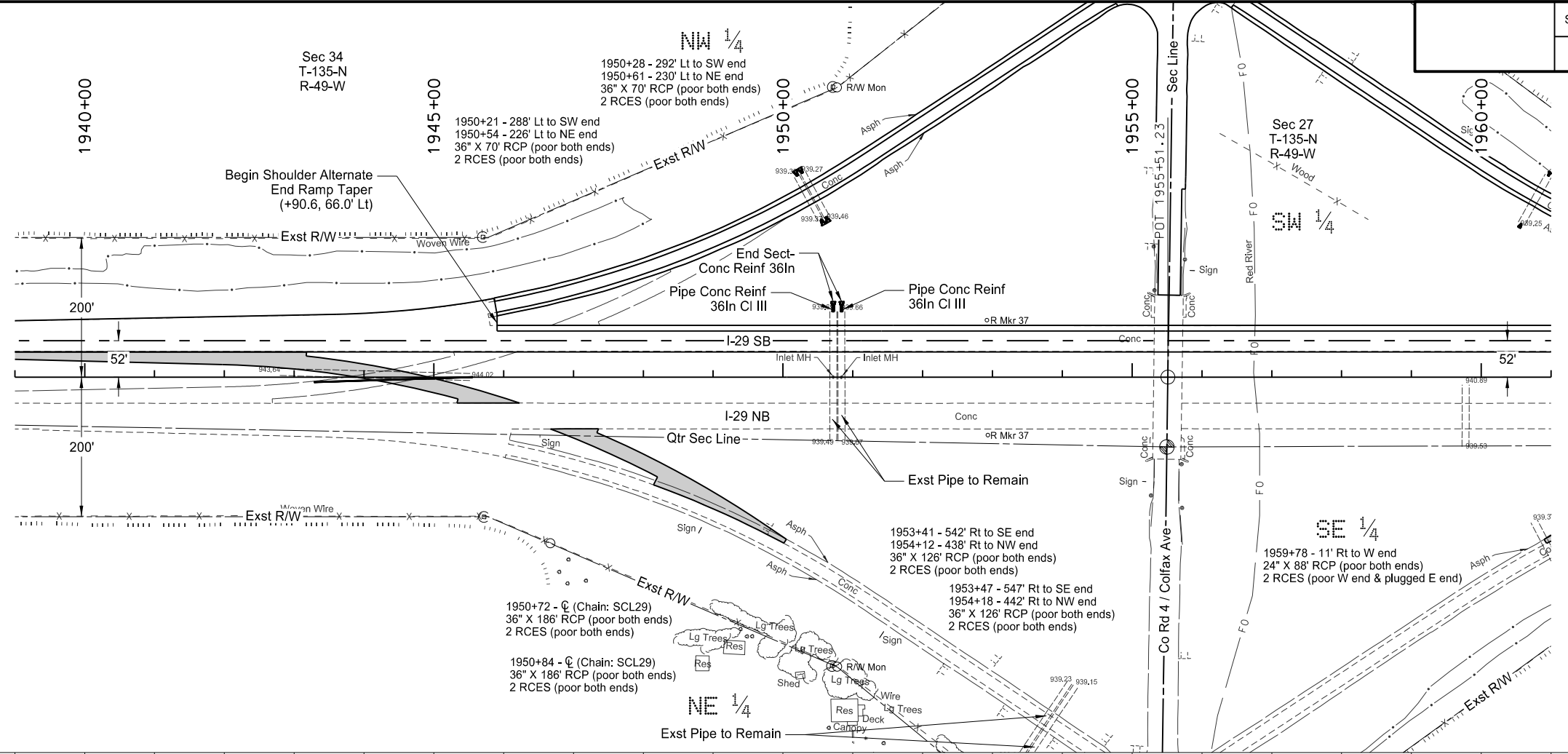

Notes:
1. Refer to Section 90 for pipe quantities on southbound interstate ramps.

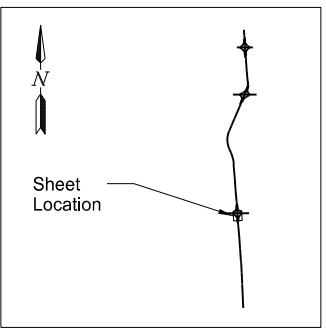

This document was originally issued and sealed by Jonathan D. Bach, Registration Number PE- 9797, on 08/07/17 and the original document is stored at the North Dakota Department of Transportation

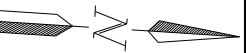
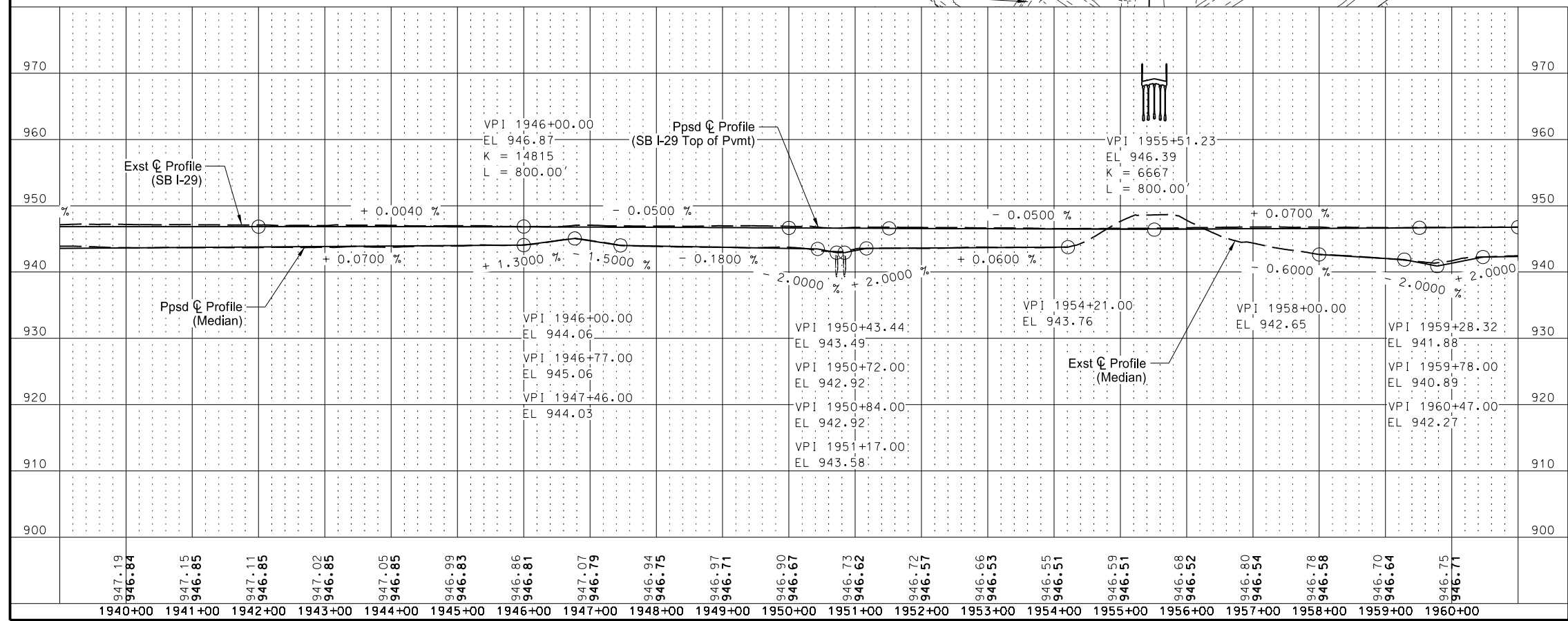

I-29 - N of Galchutt Exit to Christine Exit
Plan & Profile
Interstate 29
Sta 1940+00 to 1960+00 (SCL29)

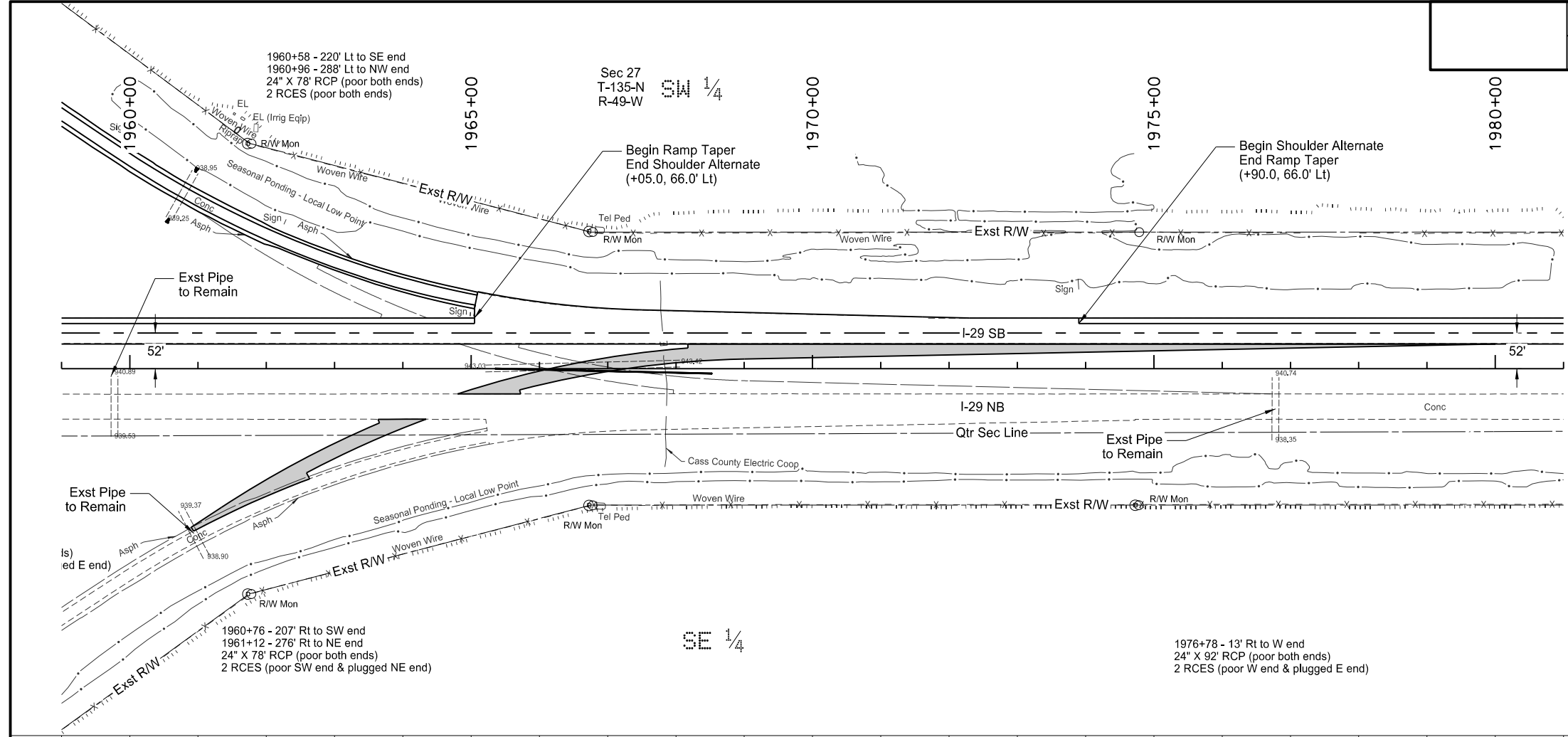

Notes:
 1. Refer to Section 90 for pipe quantities on southbound interstate ramps.

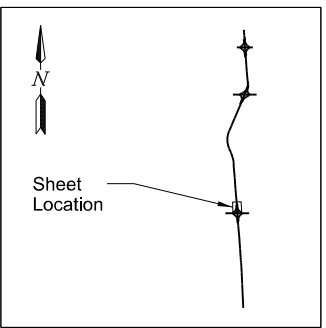
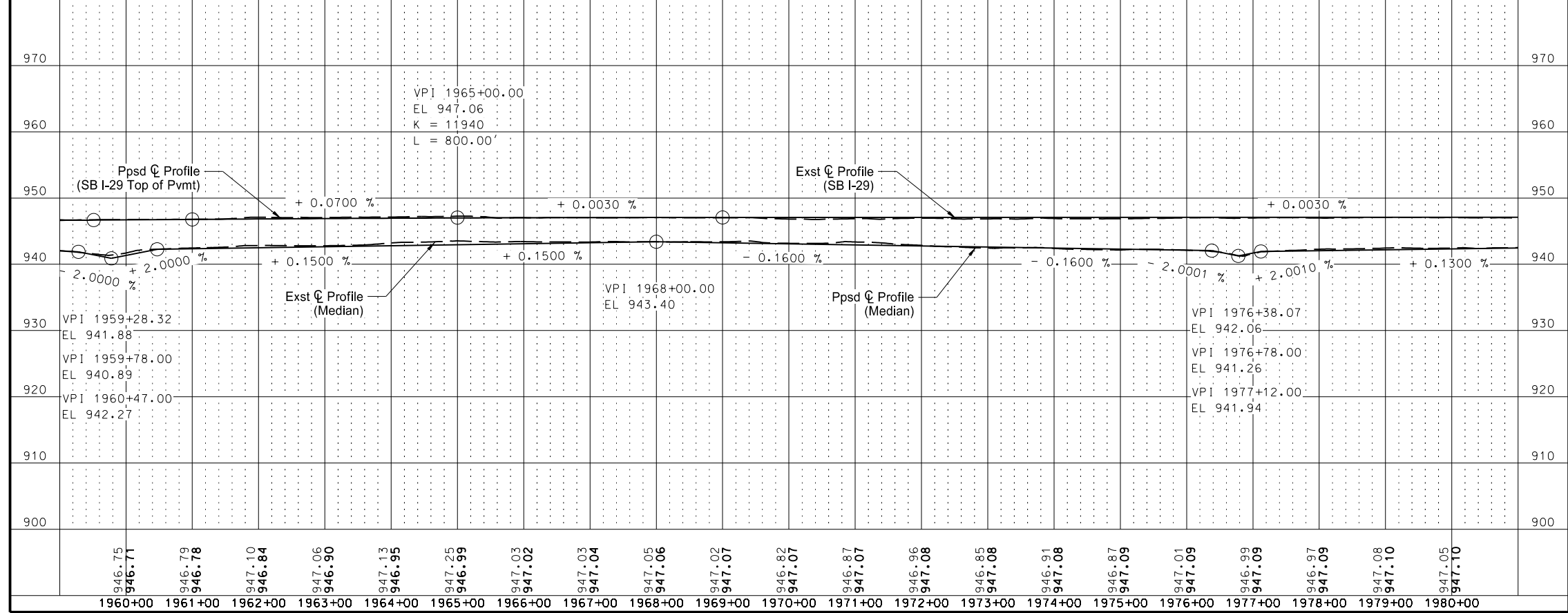

This document was originally issued and sealed by Jonathan D. Bach, Registration Number PE- 9797, on 08/07/17 and the original document is stored at the North Dakota Department of Transportation

I-29 - N of Galchutt Exit to Christine Exit
 Plan & Profile
 Interstate 29
 Sta 1960+00 to 1980+00 (SCL29)

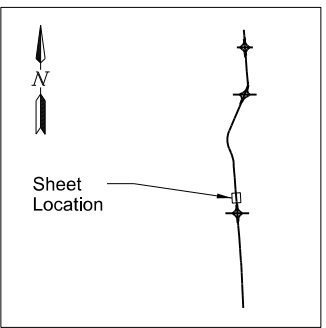
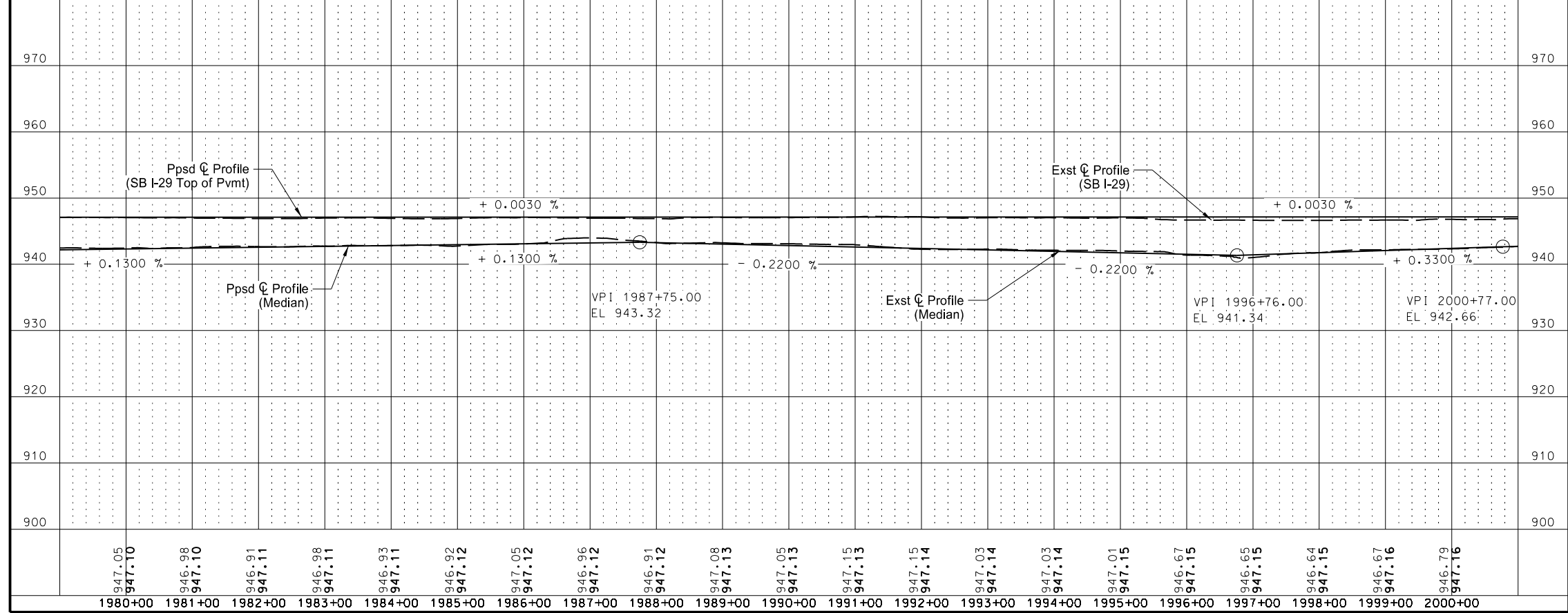
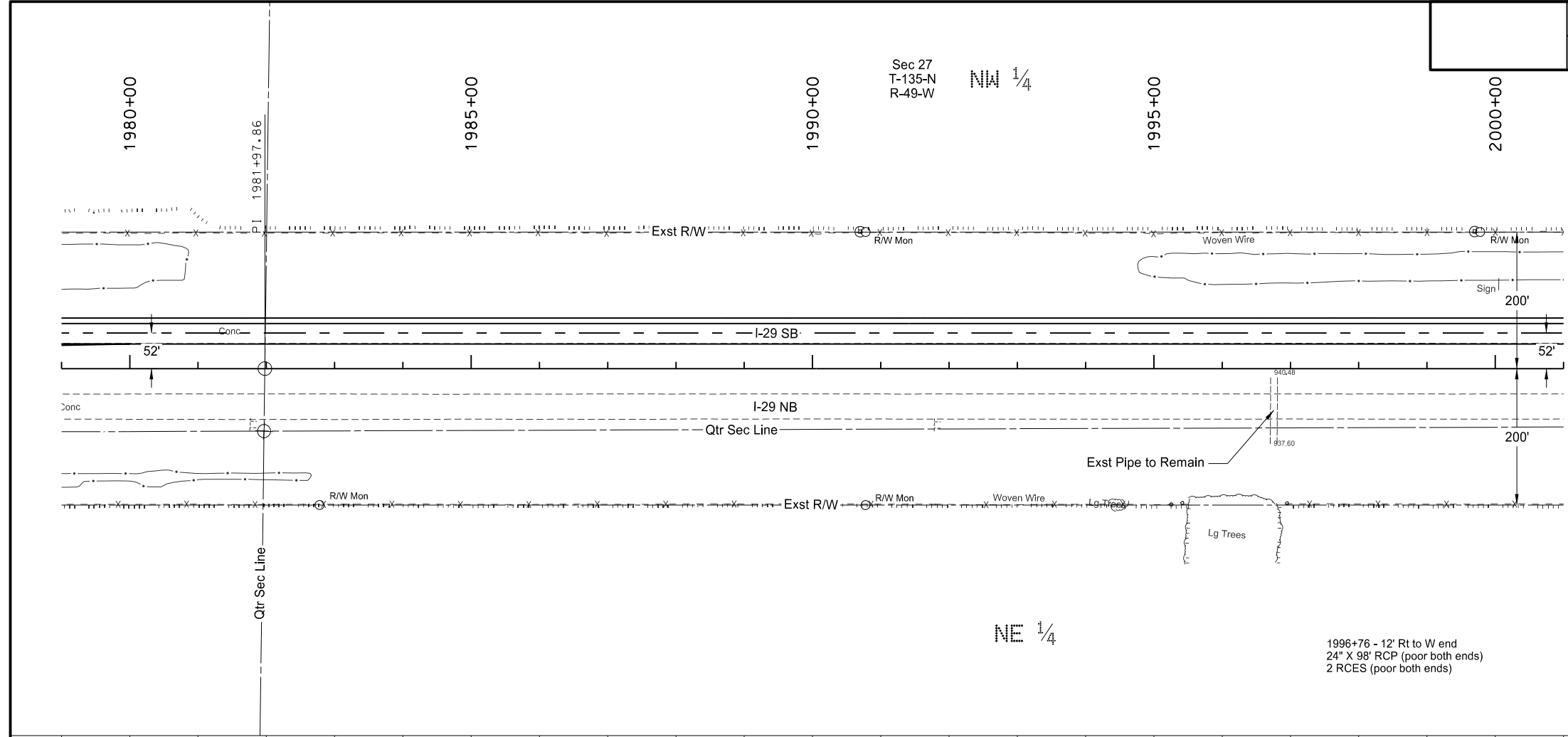

This document was originally issued and sealed by Jonathan D. Bach, Registration Number PE- 9797, on 08/07/17 and the original document is stored at the North Dakota Department of Transportation

I-29 - N of Galchutt Exit to Christine Exit
Plan & Profile
Interstate 29
Sta 1980+00 to 2000+00 (SCL29)

STATE	PROJECT NO.	SECTION NO.	SHEET NO.
ND	IM-8-029(170)033	60	13

SPEC	CODE	BID ITEM	QTY	UNIT
714	4122	PIPE CONDUIT 42IN-APPROACH		
		Sta 2006+91 ~ 166.3' Lt to Sta 2007+38 ~ 166.3' Lt	48	LF
		Sta 2006+91 ~ 156.3' Lt to Sta 2007+38 ~ 156.3' Lt	48	LF
		Sta 2006+91 ~ 146.4' Lt to Sta 2007+38 ~ 146.4' Lt	48	LF
714	9917	FLAP GATE 42IN		
		Sta 2007+38 ~ 166.3' Lt	1	EA
		Sta 2007+38 ~ 156.3' Lt	1	EA
		Sta 2007+38 ~ 146.4' Lt	1	EA

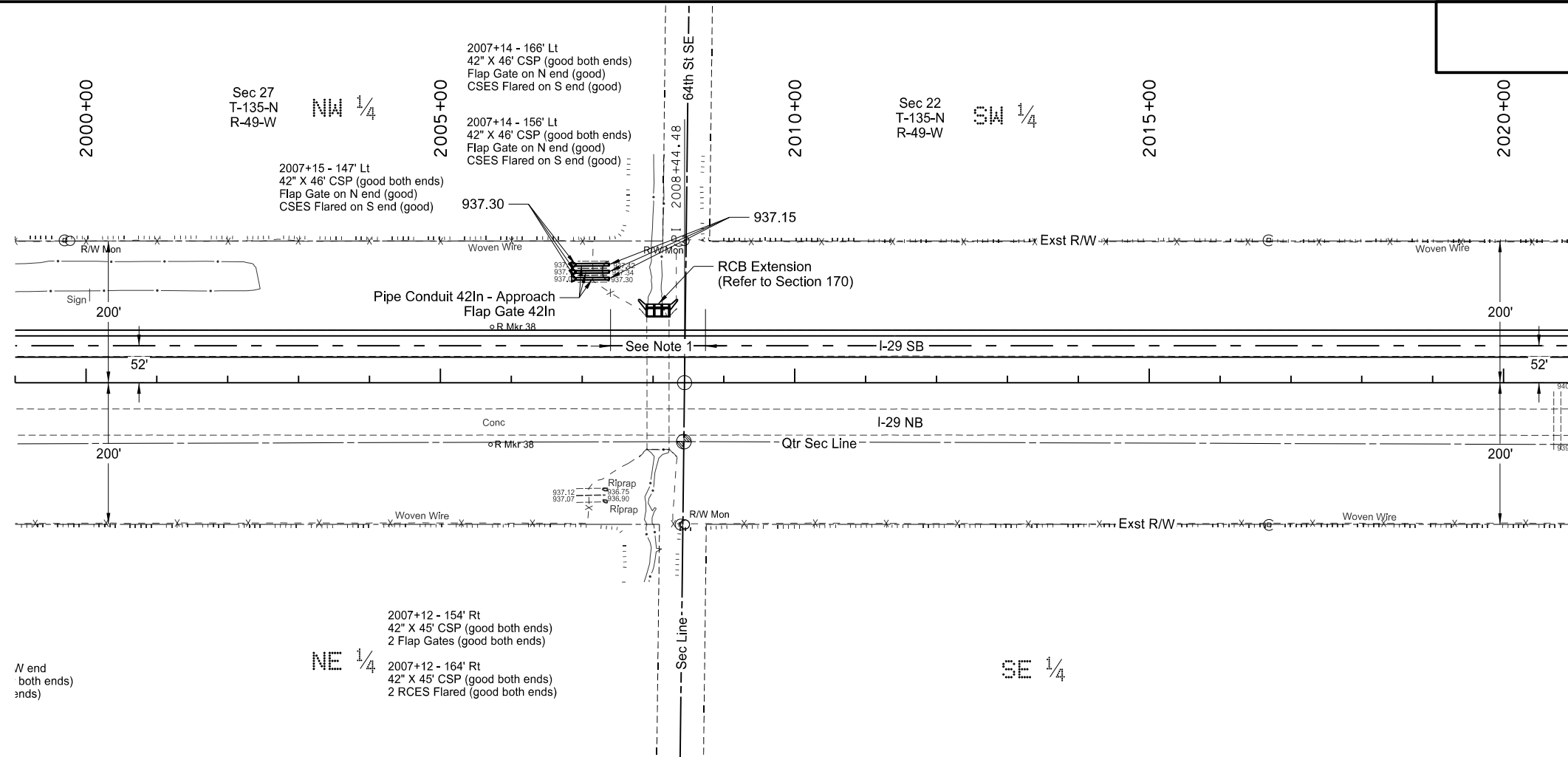

- Notes:**
- Transition inslope from 6:1 to 12:1 over 50 ft both back and ahead of RCB.
- 6:1 to 12:1: Sta 2007+40 to 2007+90
 12:1 to 12:1: Sta 2007+90 to 2008+24
 12:1 to 6:1: Sta 2008+24 to 2008+74

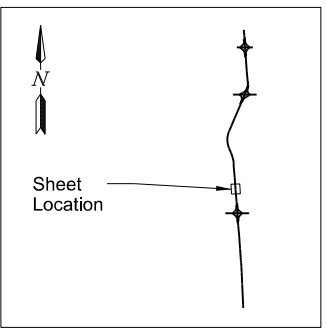
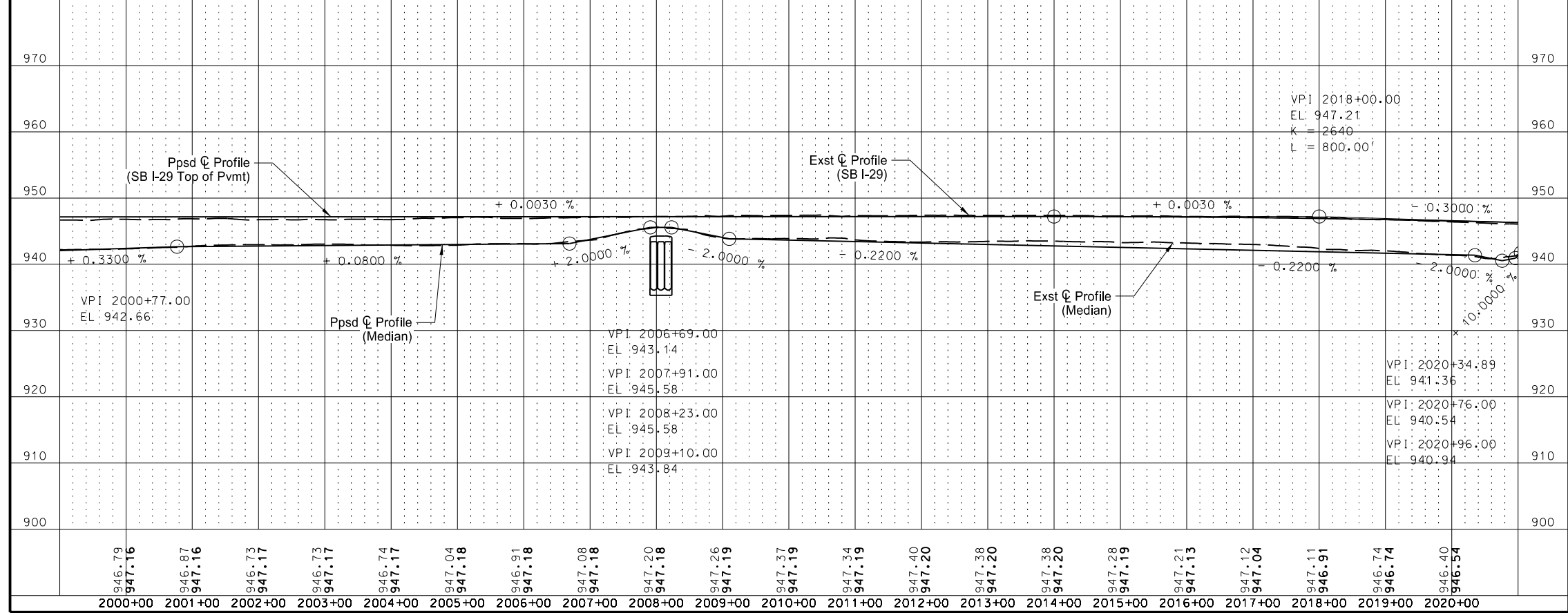

This document was originally issued and sealed by Jonathan D. Bach, Registration Number PE- 9797, on 08/07/17 and the original document is stored at the North Dakota Department of Transportation

I-29 - N of Galchutt Exit to Christine Exit
 Plan & Profile
 Interstate 29
 Sta 2000+00 to 2020+00 (SCL29)

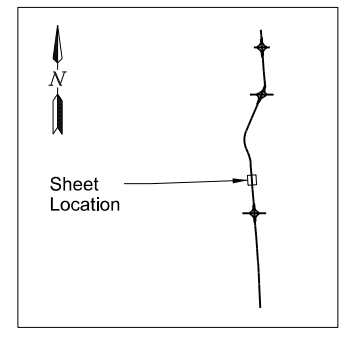
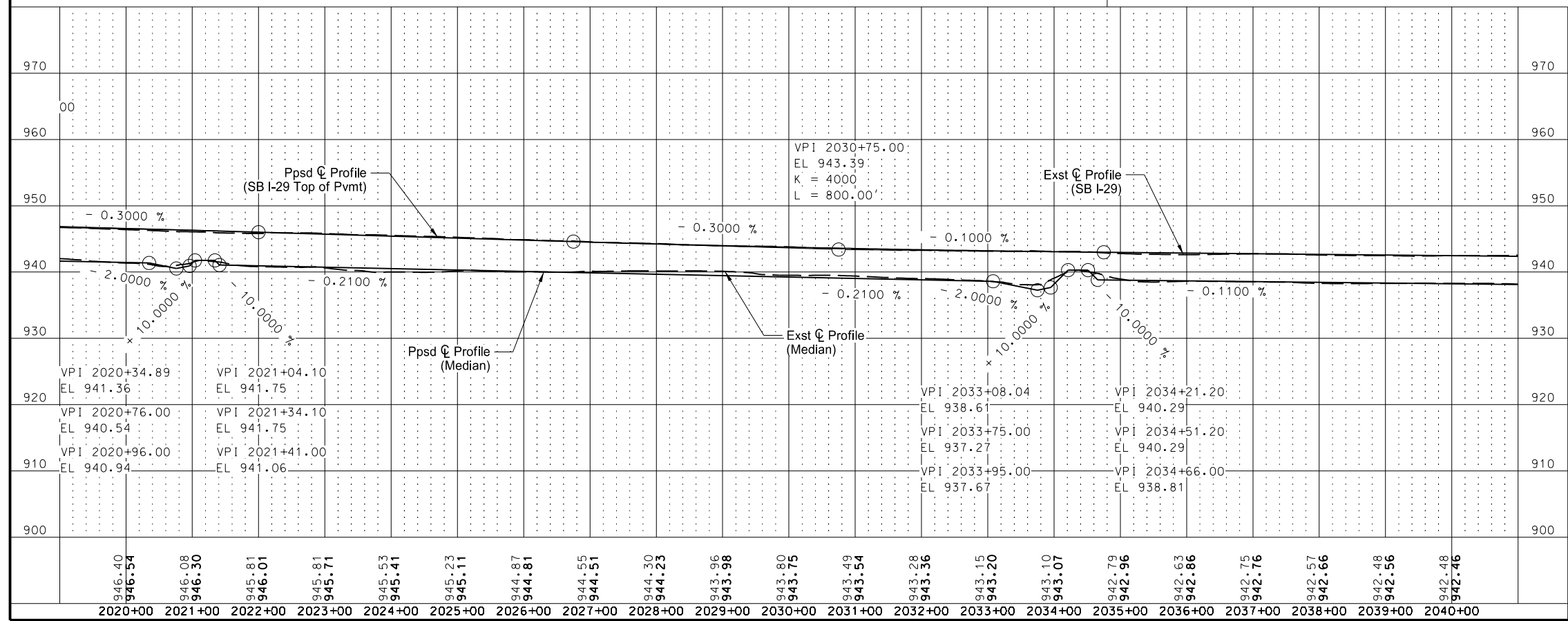
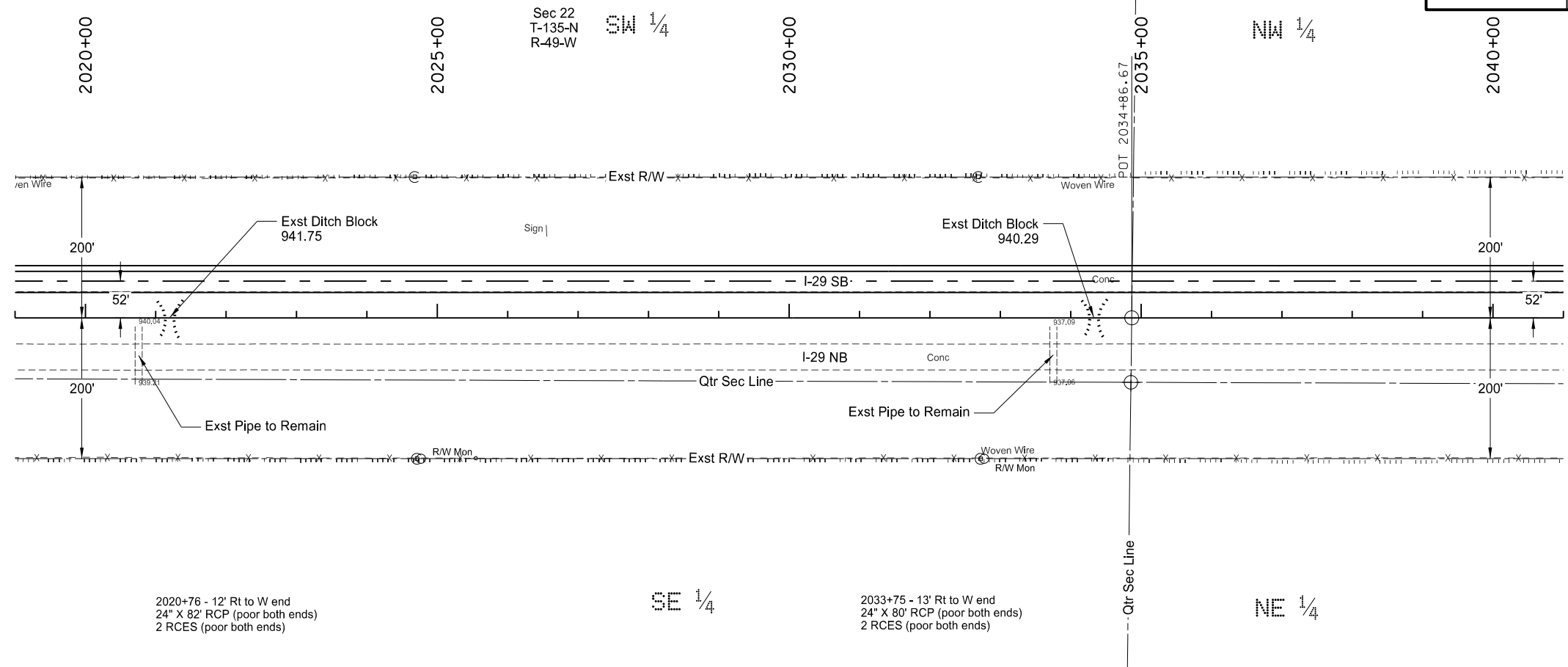

This document was originally issued and sealed by Jonathan D. Bach, Registration Number PE- 9797, on 08/07/17 and the original document is stored at the North Dakota Department of Transportation

I-29 - N of Galchutt Exit to Christine Exit
Plan & Profile
Interstate 29
Sta 2020+00 to 2040+00 (SCL29)

STATE	PROJECT NO.	SECTION NO.	SHEET NO.
ND	IM-8-029(170)033	60	15

SPEC	CODE	BID ITEM	QTY	UNIT
714	0905	PIPE CONC REINF 36IN CL III Sta 2058+76 ~ 91.3' Lt to Sta 2058+76 ~ 97.3' Lt	6	LF
714	3035	END SECT-CONC REINF 36IN Sta 2058+76 ~ 97.3' Lt	1	EA
714	3036	END SECT-TRAVERSABLE REINF. CONC.36IN Sta 2058+76 ~ 12.5' Lt	1	EA

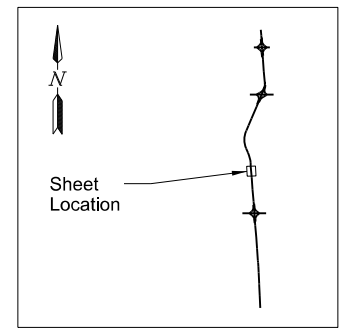
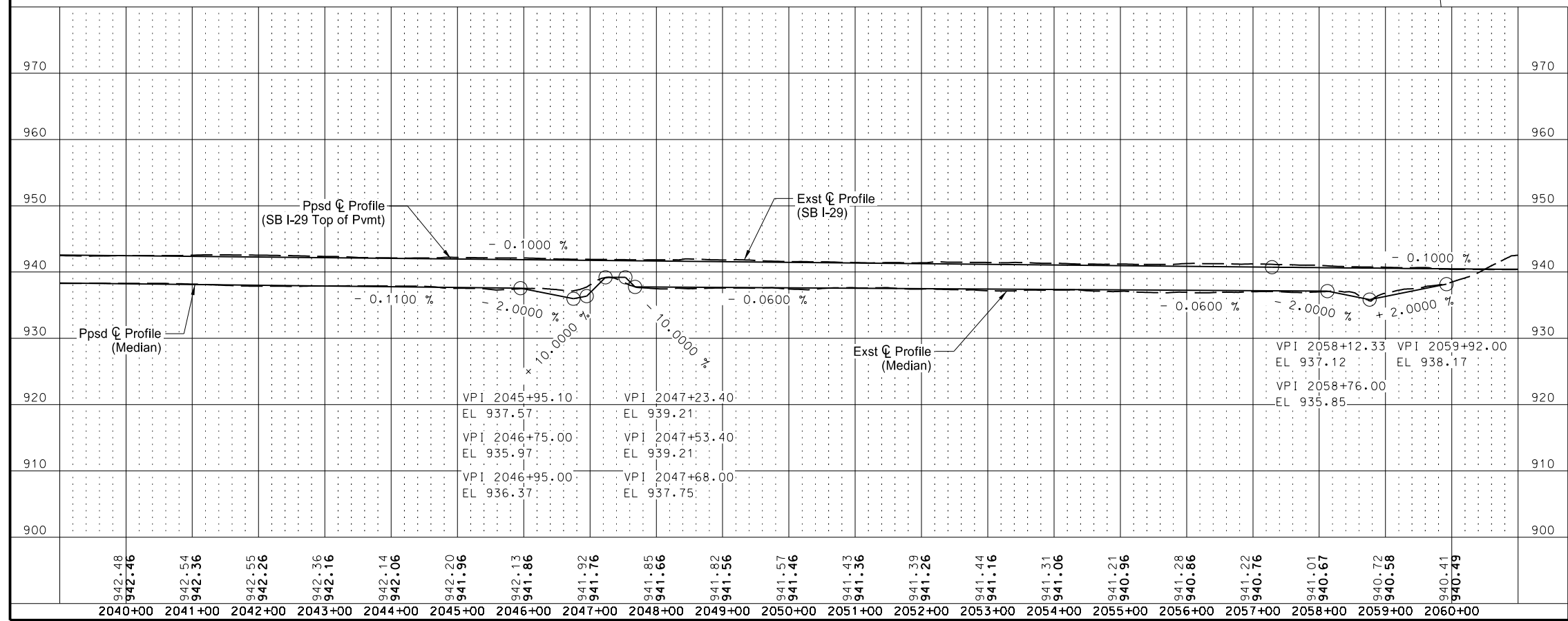
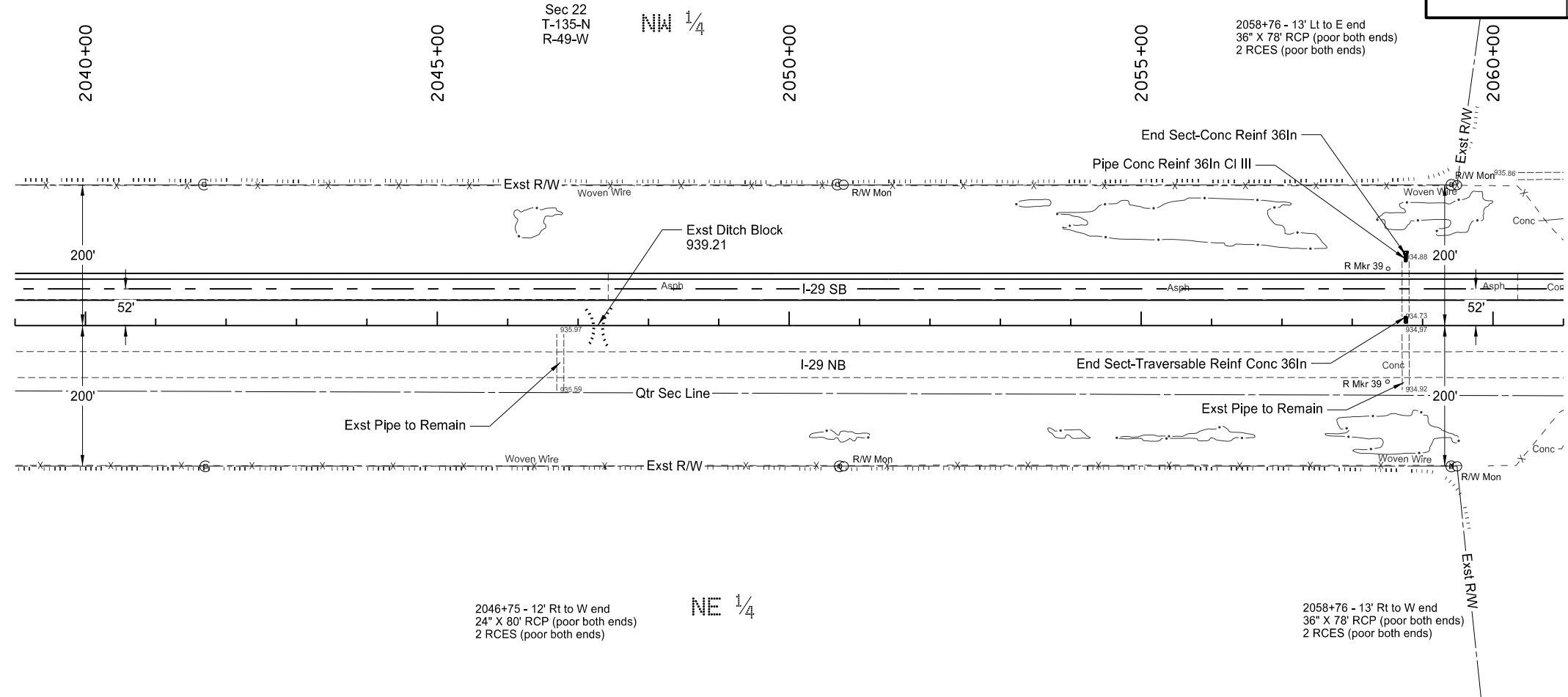

This document was originally issued and sealed by Jonathan D. Bach, Registration Number PE- 9797, on 08/07/17 and the original document is stored at the North Dakota Department of Transportation

I-29 - N of Galchutt Exit to Christine Exit
Plan & Profile
Interstate 29
Sta 2040+00 to 2060+00 (SCL29)

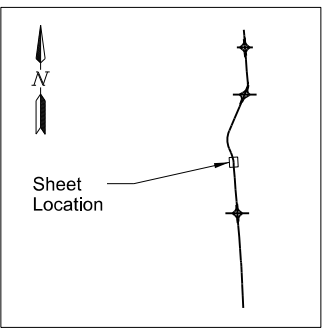
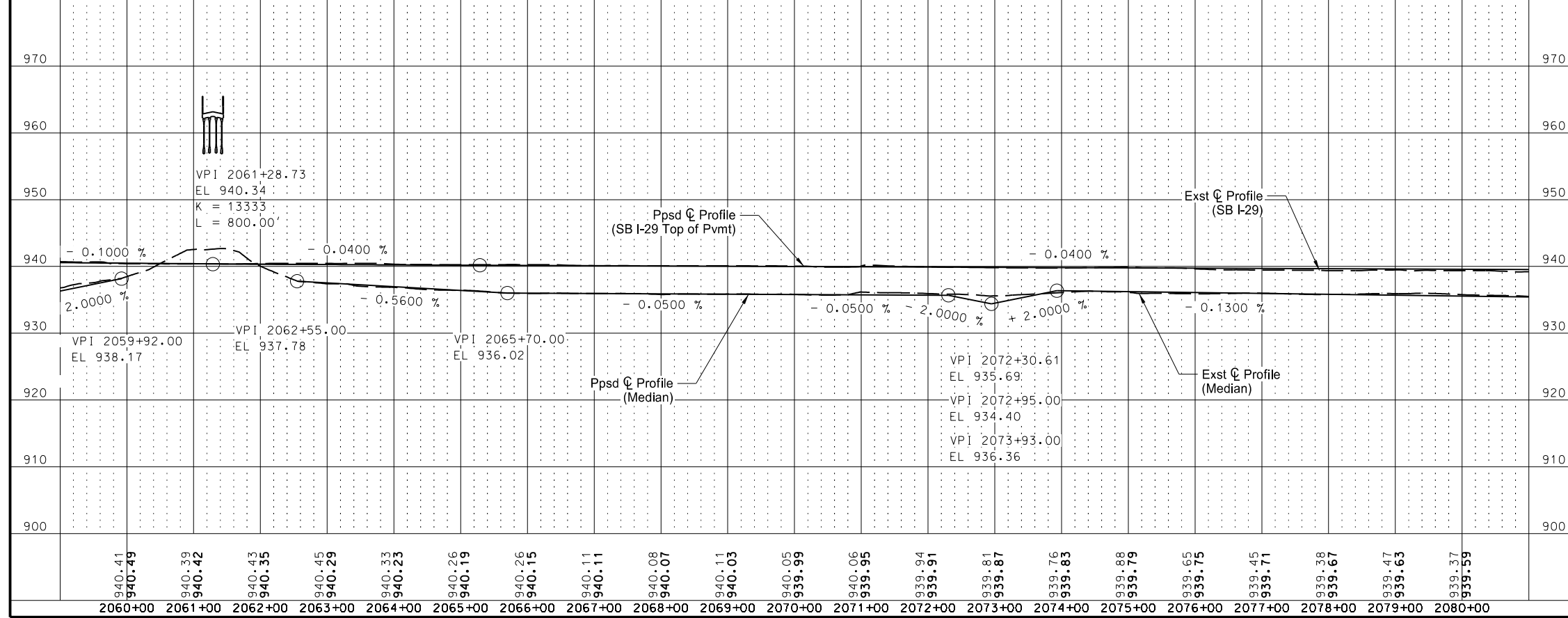
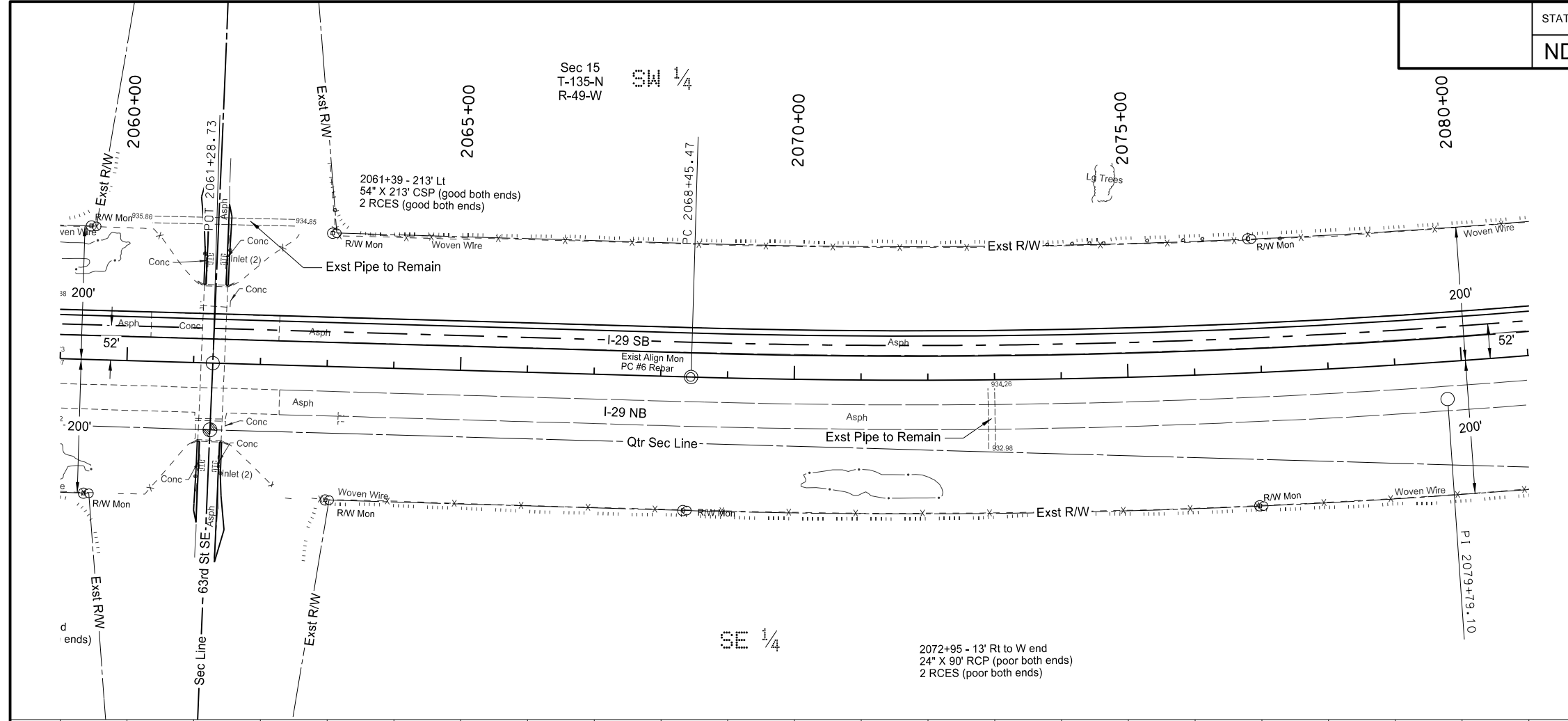

This document was originally issued and sealed by Jonathan D. Bach, Registration Number PE- 9797, on 08/07/17 and the original document is stored at the North Dakota Department of Transportation

I-29 - N of Galchutt Exit to Christine Exit
Plan & Profile
Interstate 29
Sta 2060+00 to 2080+00 (SCL29)

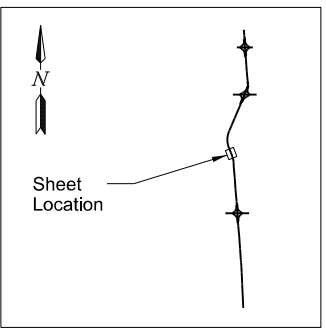
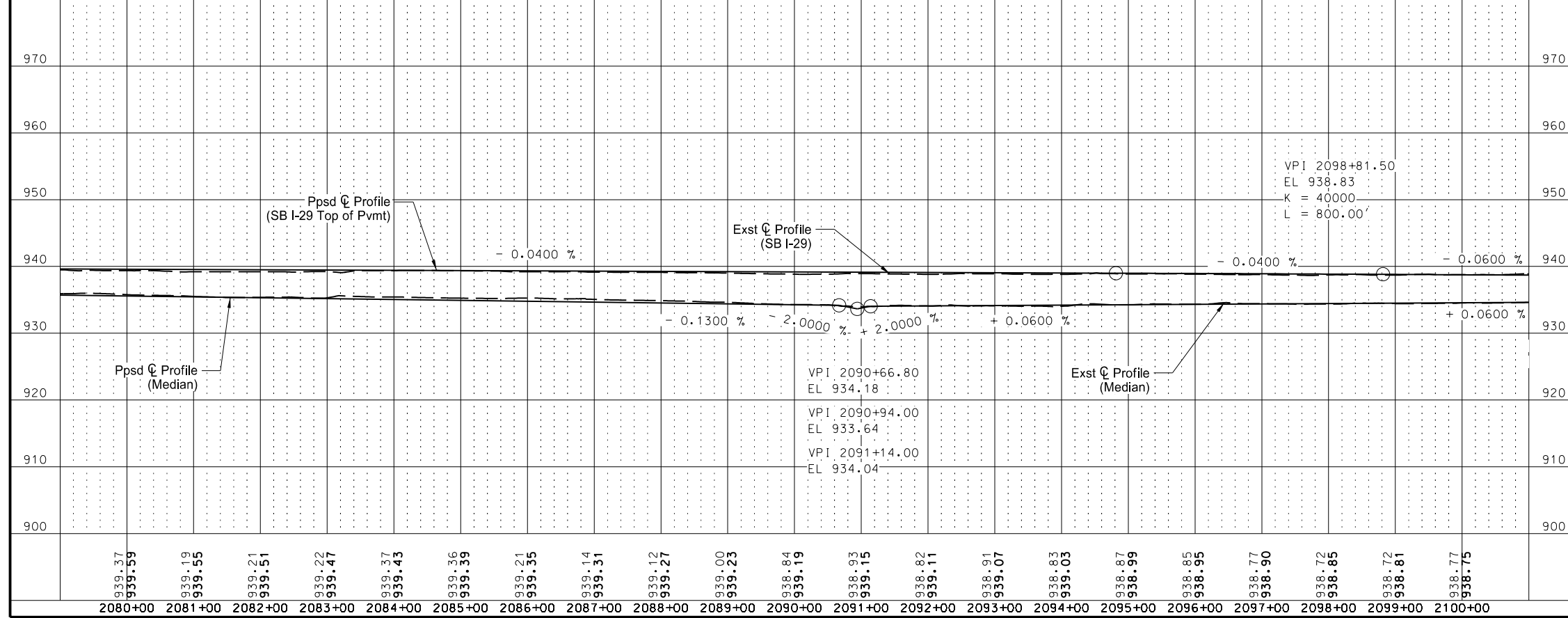
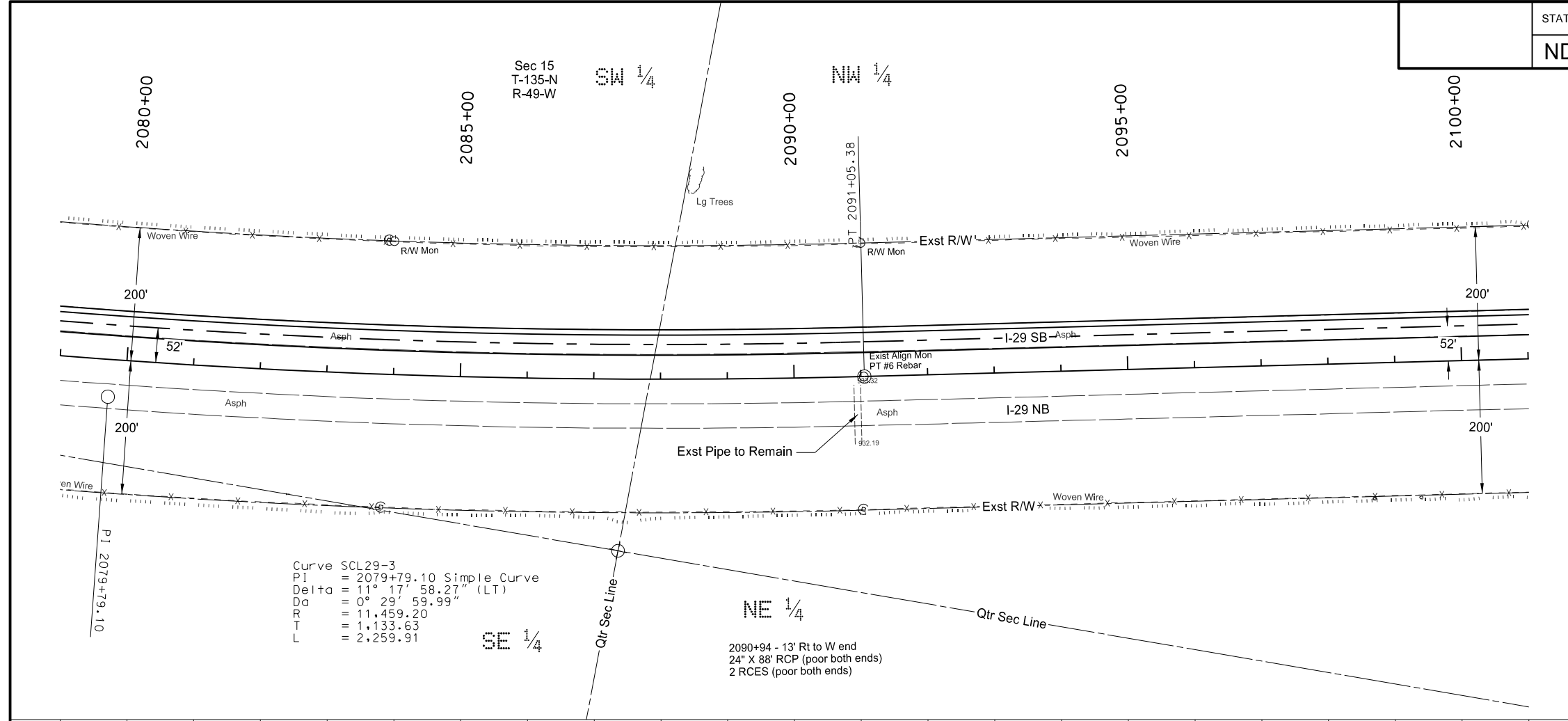

This document was originally issued and sealed by Jonathan D. Bach, Registration Number PE- 9797, on 08/07/17 and the original document is stored at the North Dakota Department of Transportation

I-29 - N of Galchutt Exit to Christine Exit
 Plan & Profile
 Interstate 29
 Sta 2080+00 to 2100+00 (SCL29)

STATE	PROJECT NO.	SECTION NO.	SHEET NO.
ND	IM-8-029(170)033	60	18

SPEC	CODE	BID ITEM	QTY	UNIT
714	3020	END SECT-CONC REINF 24IN Sta 2108+94 ~ 108.2' Lt	1	EA
714	3023	END SECT-TRAVERSABLE REINF. CONC.24IN Sta 2108+94 ~ 13.2' Lt	1	EA

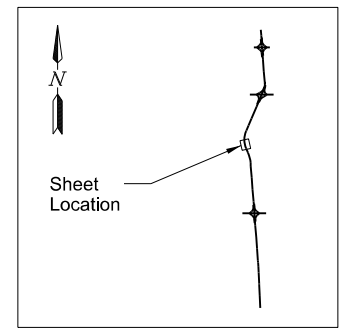
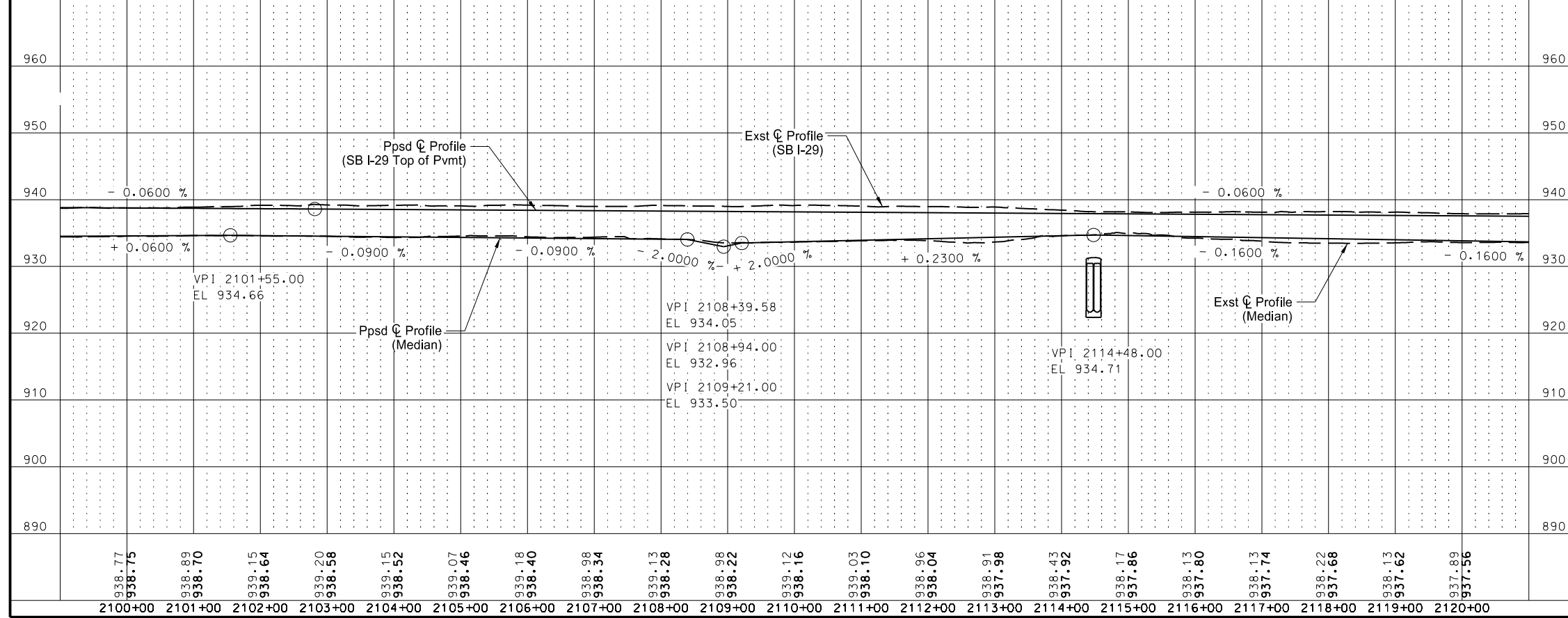
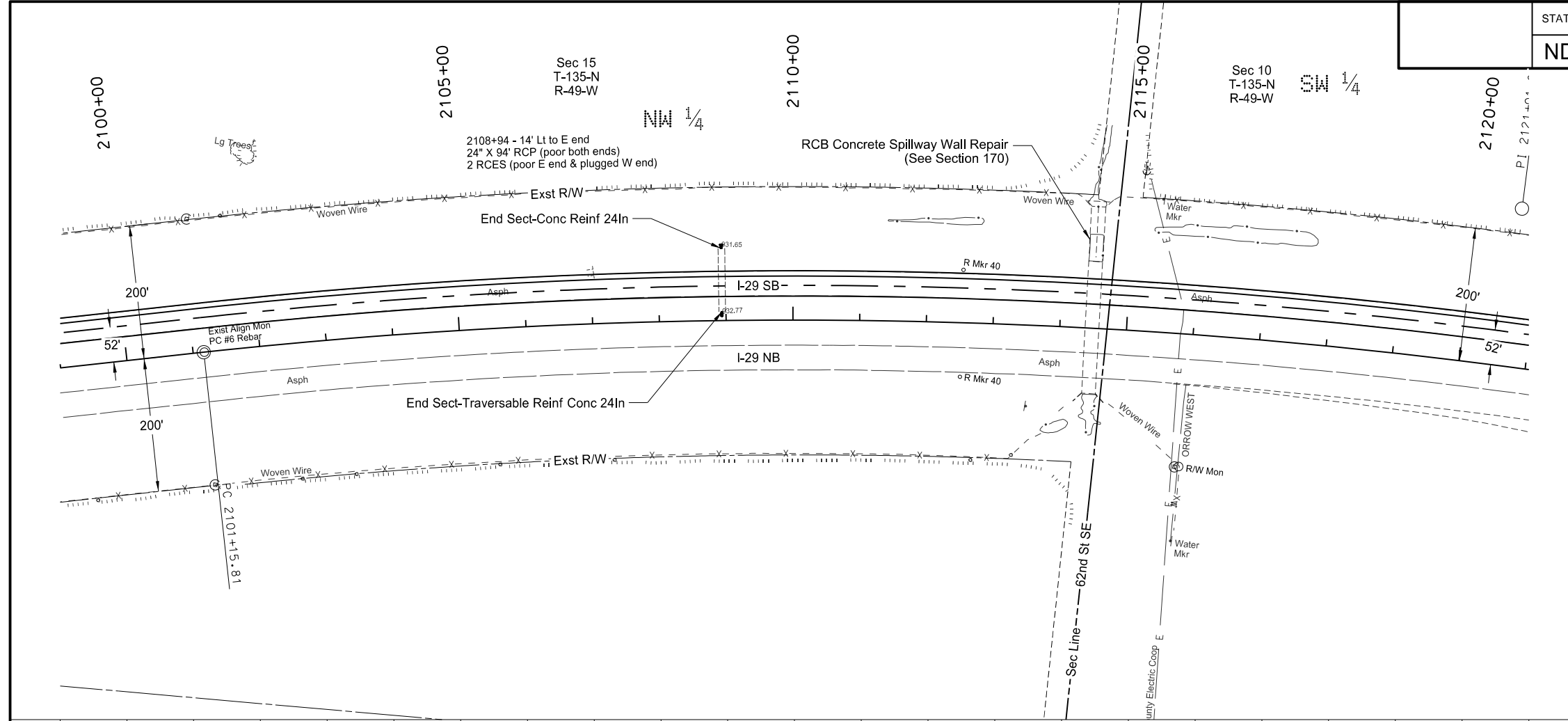

This document was originally issued and sealed by Jonathan D. Bach, Registration Number PE- 9797, on 08/07/17 and the original document is stored at the North Dakota Department of Transportation

I-29 - N of Galchutt Exit to Christine Exit
Plan & Profile
Interstate 29
Sta 2100+00 to 2120+00 (SCL29)

STATE	PROJECT NO.	SECTION NO.	SHEET NO.
ND	IM-8-029(170)033	60	19

SPEC	CODE	BID ITEM	QTY	UNIT
714	3030	END SECT-CONC REINF 30IN		
		Sta 2123+92 ~ 128.7' Lt	1	EA
		Sta 2138+94 ~ 118.7' Lt	1	EA
714	3033	END SECT-TRAVERSABLE REINF. CONC.30IN		
		Sta 2123+92 ~ 15.3' Lt	1	EA
		Sta 2138+94 ~ 15.6' Lt	1	EA

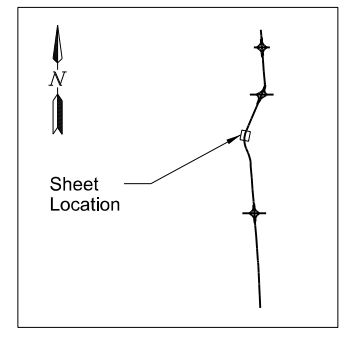
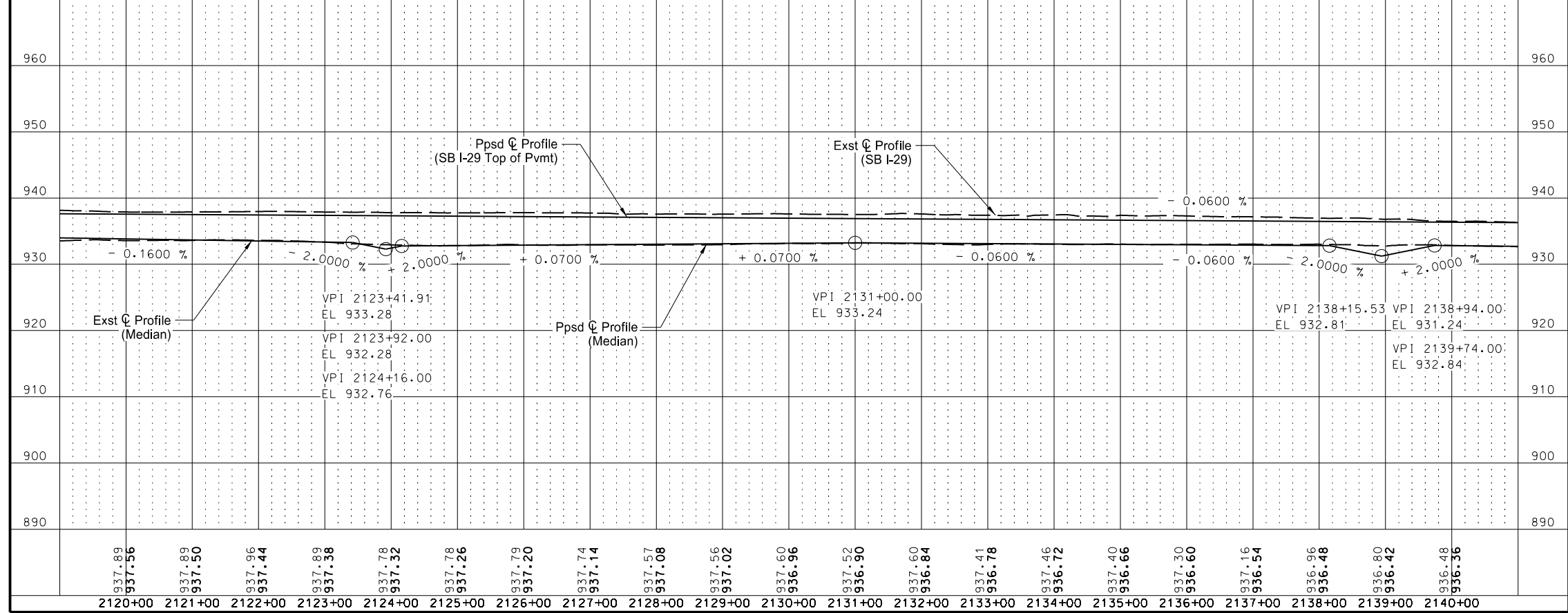
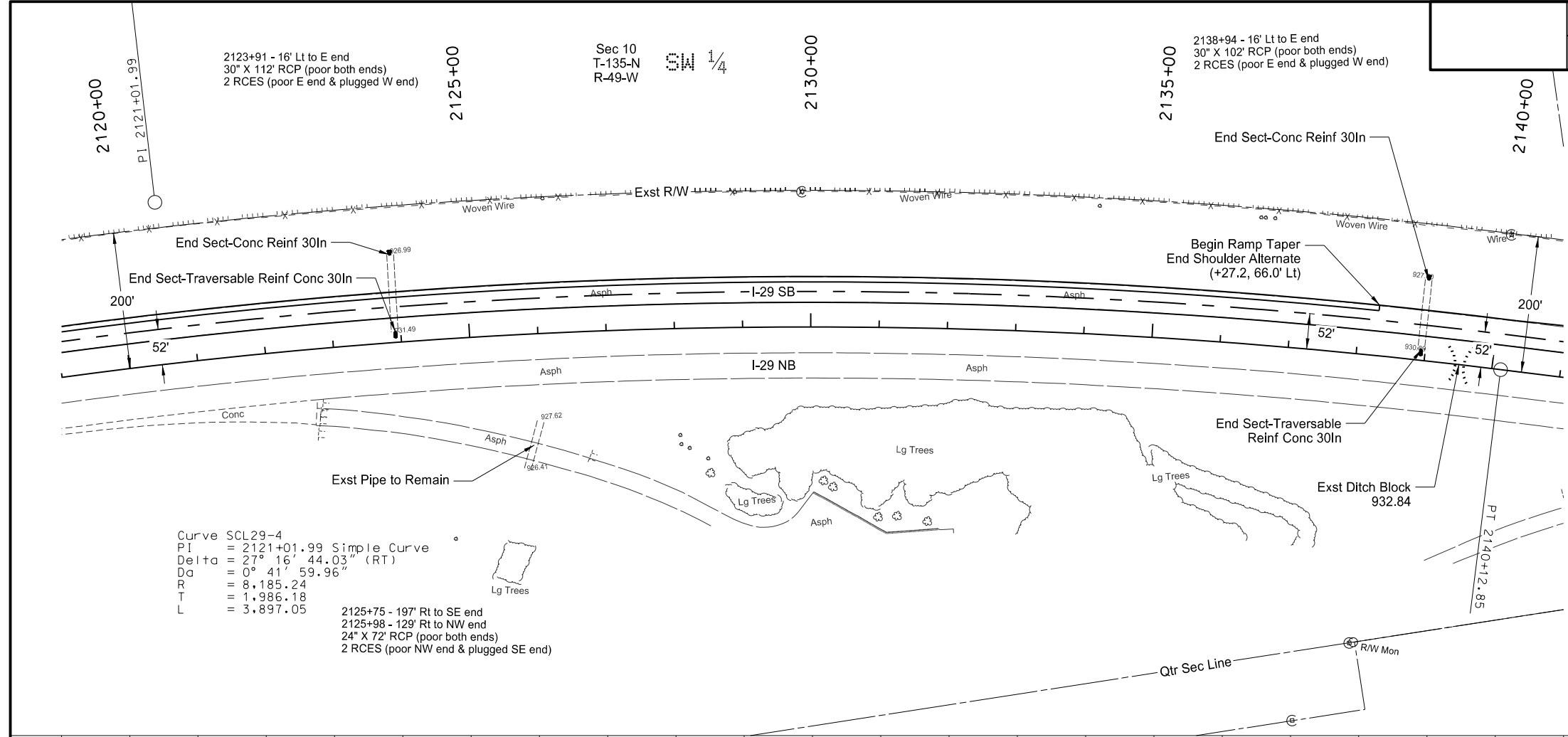

This document was originally issued and sealed by Jonathan D. Bach, Registration Number PE- 9797, on 08/07/17 and the original document is stored at the North Dakota Department of Transportation

I-29 - N of Galchutt Exit to Christine Exit
 Plan & Profile
 Interstate 29
 Sta 2120+00 to 2140+00 (SCL29)

STATE	PROJECT NO.	SECTION NO.	SHEET NO.
ND	IM-8-029(170)033	60	20

SPEC	CODE	BID ITEM	QTY	UNIT
714	0615	PIPE CONC REINF 24IN CL III Sta 2156+91 ~ 92.5' Lt to Sta 2156+91 ~ 98.5' Lt	6	LF
714	3020	END SECT-CONC REINF 24IN Sta 2156+91 ~ 98.5' Lt	1	EA
714	3023	END SECT-TRAVERSABLE REINF. CONC.24IN Sta 2156+91 ~ 11.1' Lt	1	EA

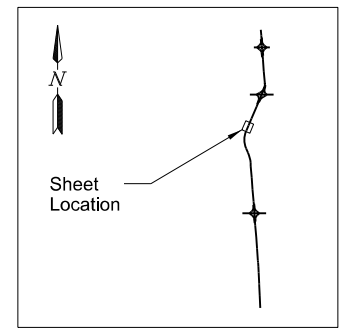
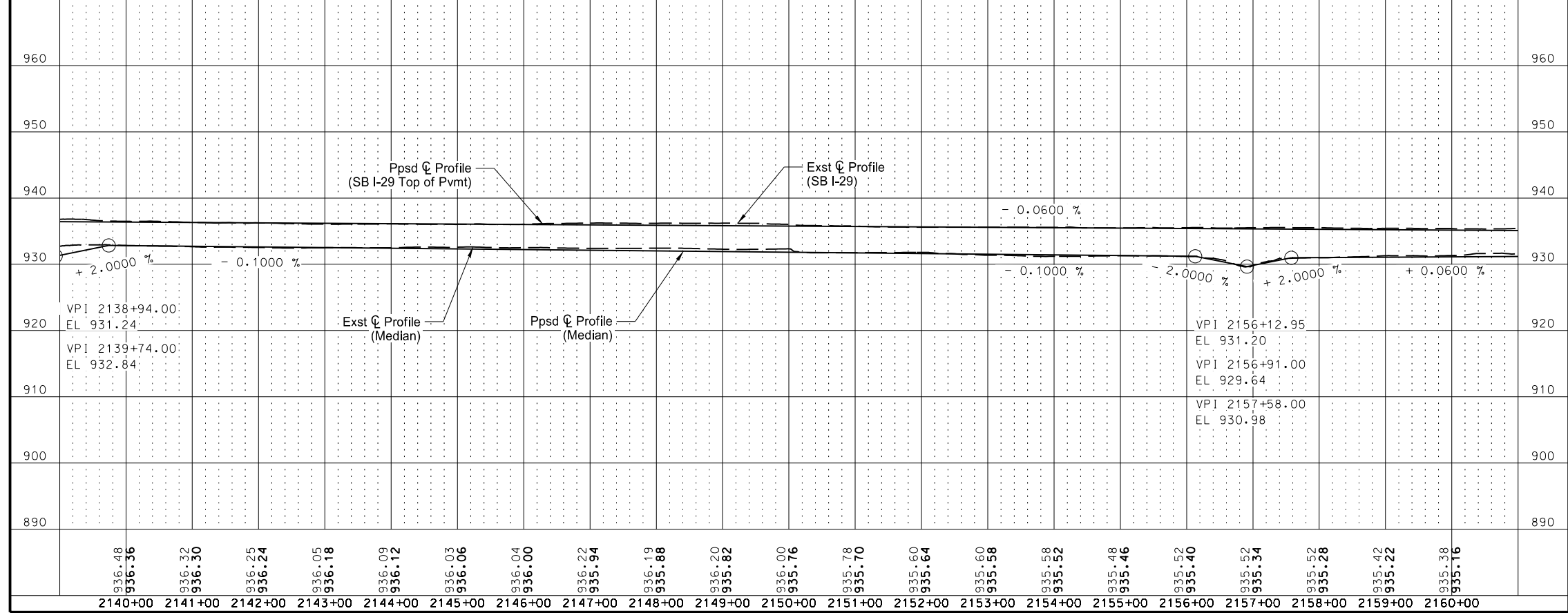
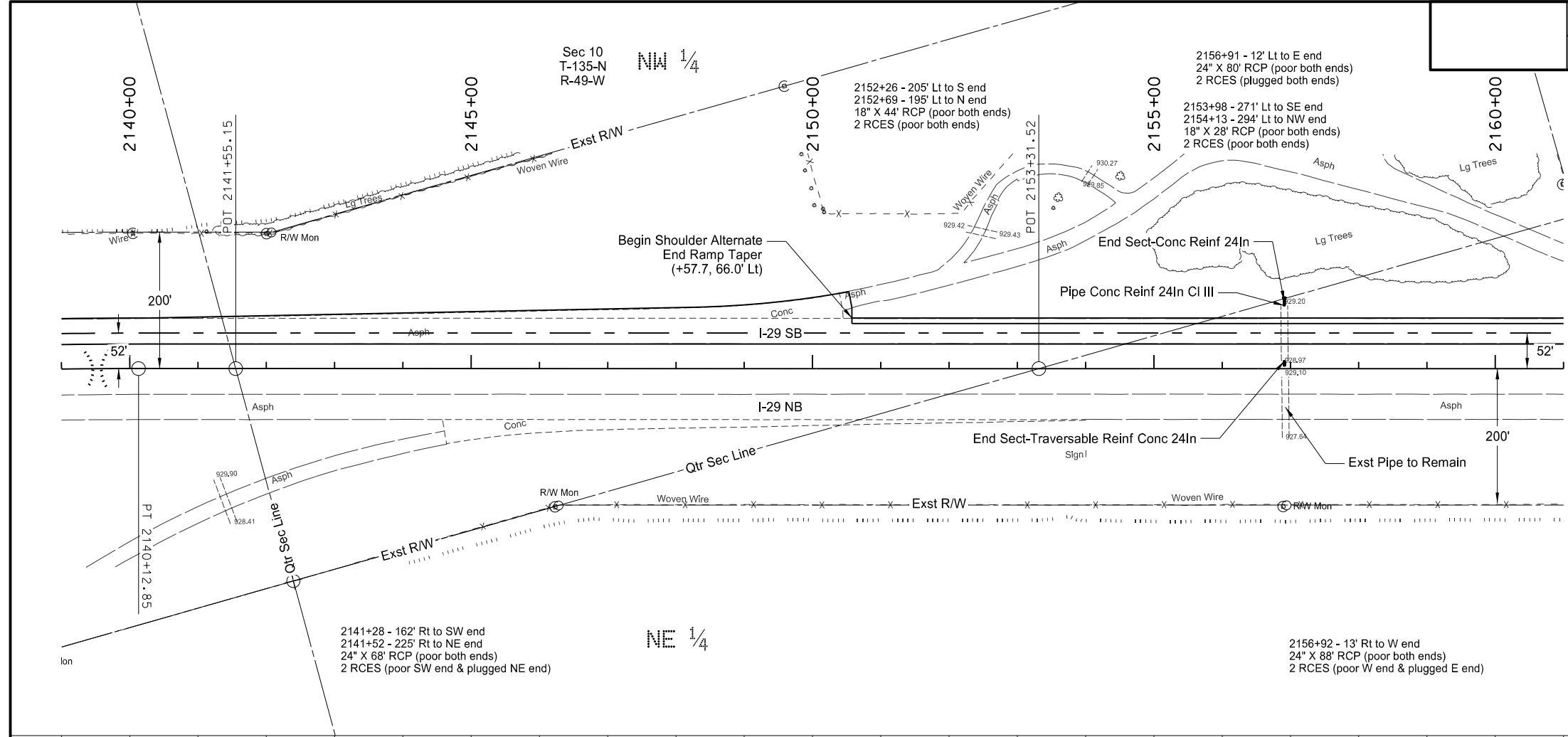

This document was originally issued and sealed by Jonathan D. Bach, Registration Number PE- 9797, on 08/07/17 and the original document is stored at the North Dakota Department of Transportation

I-29 - N of Galchutt Exit to Christine Exit
Plan & Profile
Interstate 29
Sta 2140+00 to 2160+00 (SCL29)

STATE	PROJECT NO.	SECTION NO.	SHEET NO.
ND	IM-8-029(170)033	60	21

SPEC	CODE	BID ITEM	QTY	UNIT
714	3020	END SECT-CONC REINF 24IN		
		Sta 2173+94 ~ 7.5' Lt	1	EA
		Sta 2173+94 ~ 100.6' Lt	1	EA
714	3035	END SECT-CONC REINF 36IN		
		Sta 2166+93 ~ 104.8' Lt	1	EA

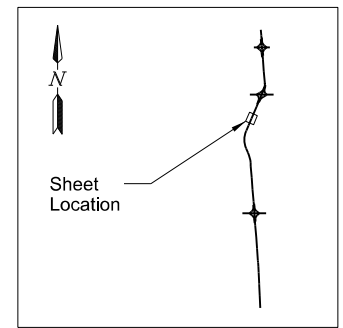
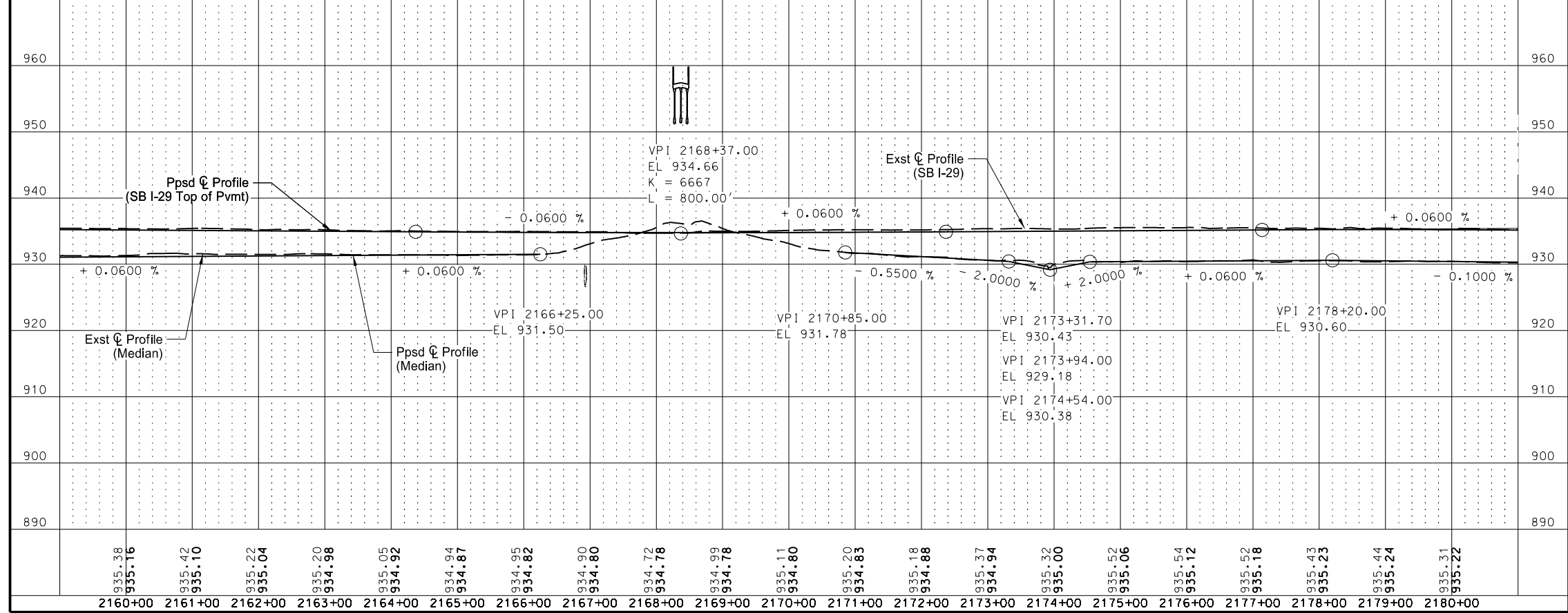
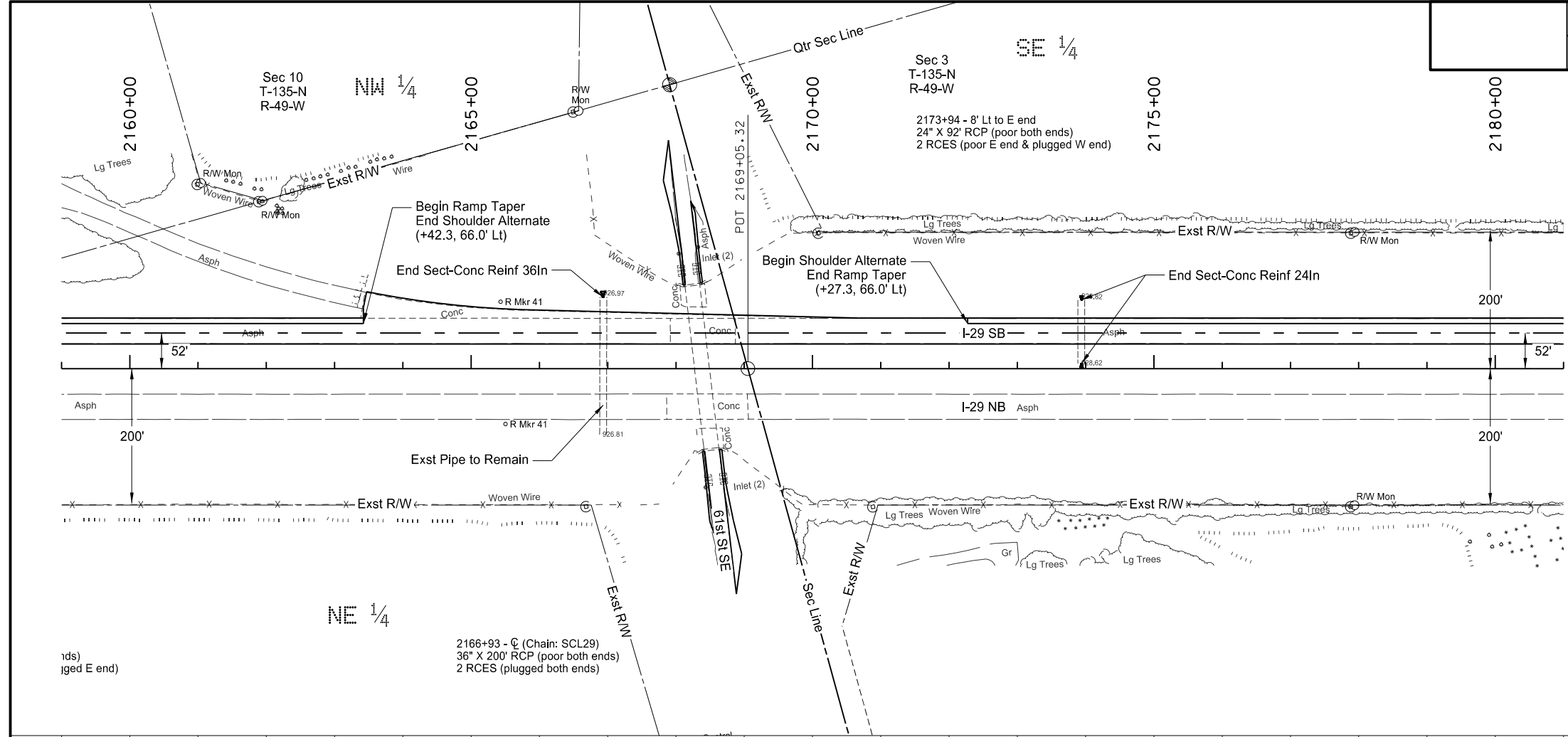

This document was originally issued and sealed by Jonathan D. Bach, Registration Number PE- 9797, on 08/07/17 and the original document is stored at the North Dakota Department of Transportation

I-29 - N of Galchutt Exit to Christine Exit
Plan & Profile
Interstate 29
Sta 2160+00 to 2180+00 (SCL29)

STATE	PROJECT NO.	SECTION NO.	SHEET NO.
ND	IM-8-029(170)033	60	22

SPEC	CODE	BID ITEM	QTY	UNIT
714	3020	END SECT-CONC REINF 24IN Sta 2189+93 ~ 101.0' Lt	1	EA
714	3023	END SECT-TRAVERSABLE REINF. CONC.24IN Sta 2189+93 ~ 12.2' Lt	1	EA

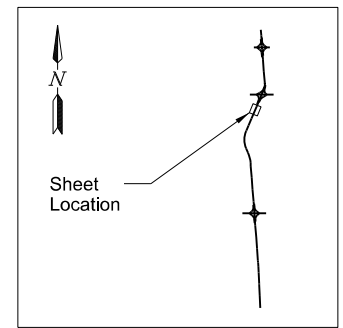
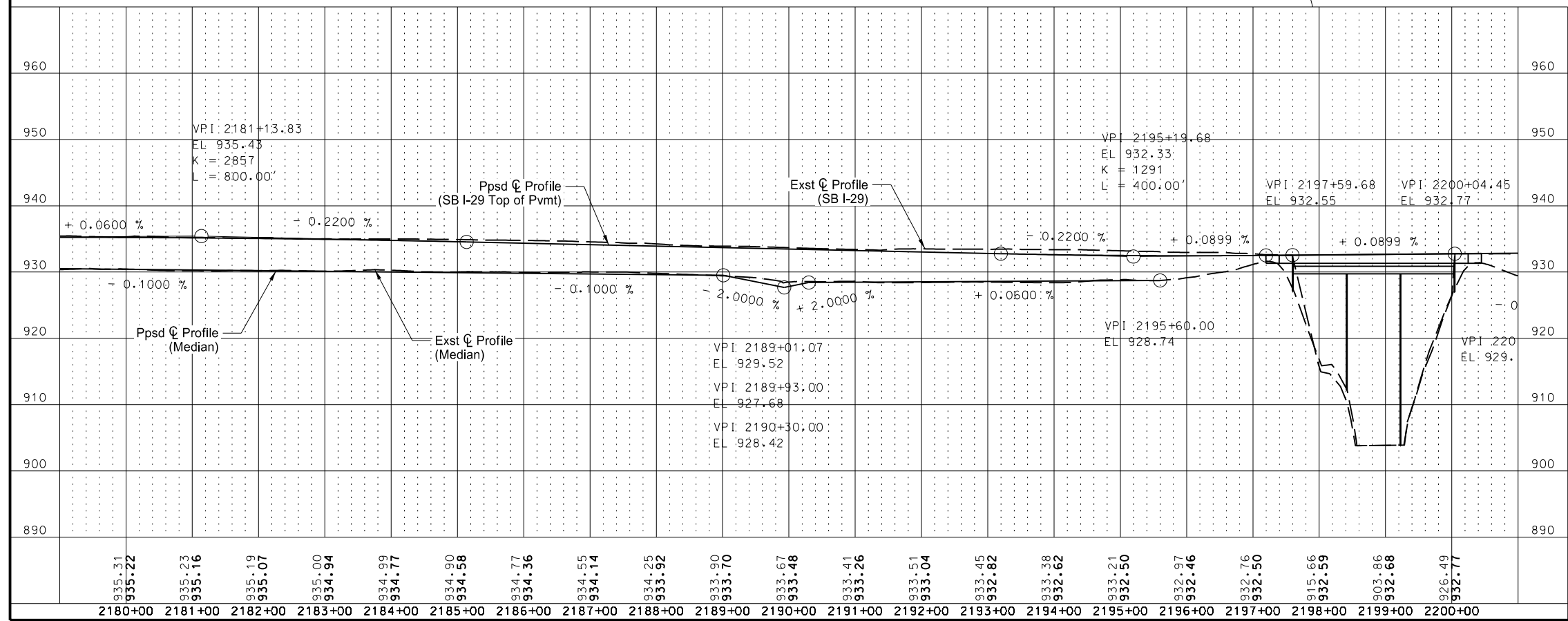
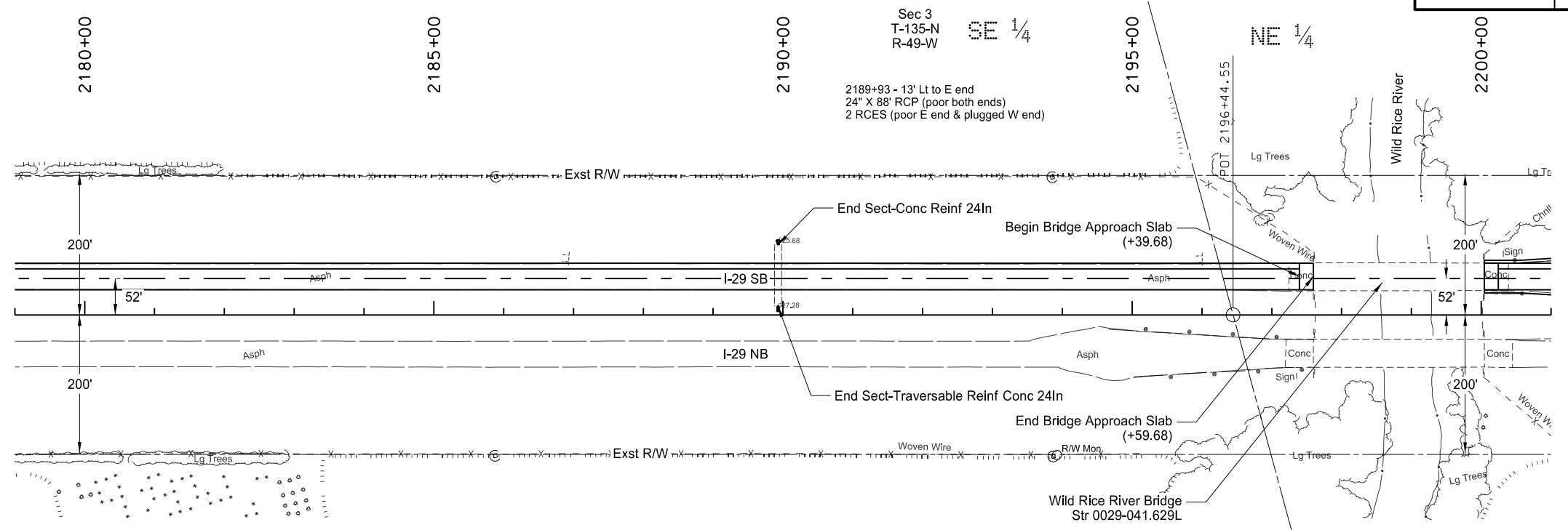

This document was originally issued and sealed by Jonathan D. Bach, Registration Number PE- 9797, on 08/07/17 and the original document is stored at the North Dakota Department of Transportation

I-29 - N of Galchutt Exit to Christine Exit
Plan & Profile
Interstate 29
Sta 2180+00 to 2200+00 (SCL29)

STATE	PROJECT NO.	SECTION NO.	SHEET NO.
ND	IM-8-029(170)033	60	23

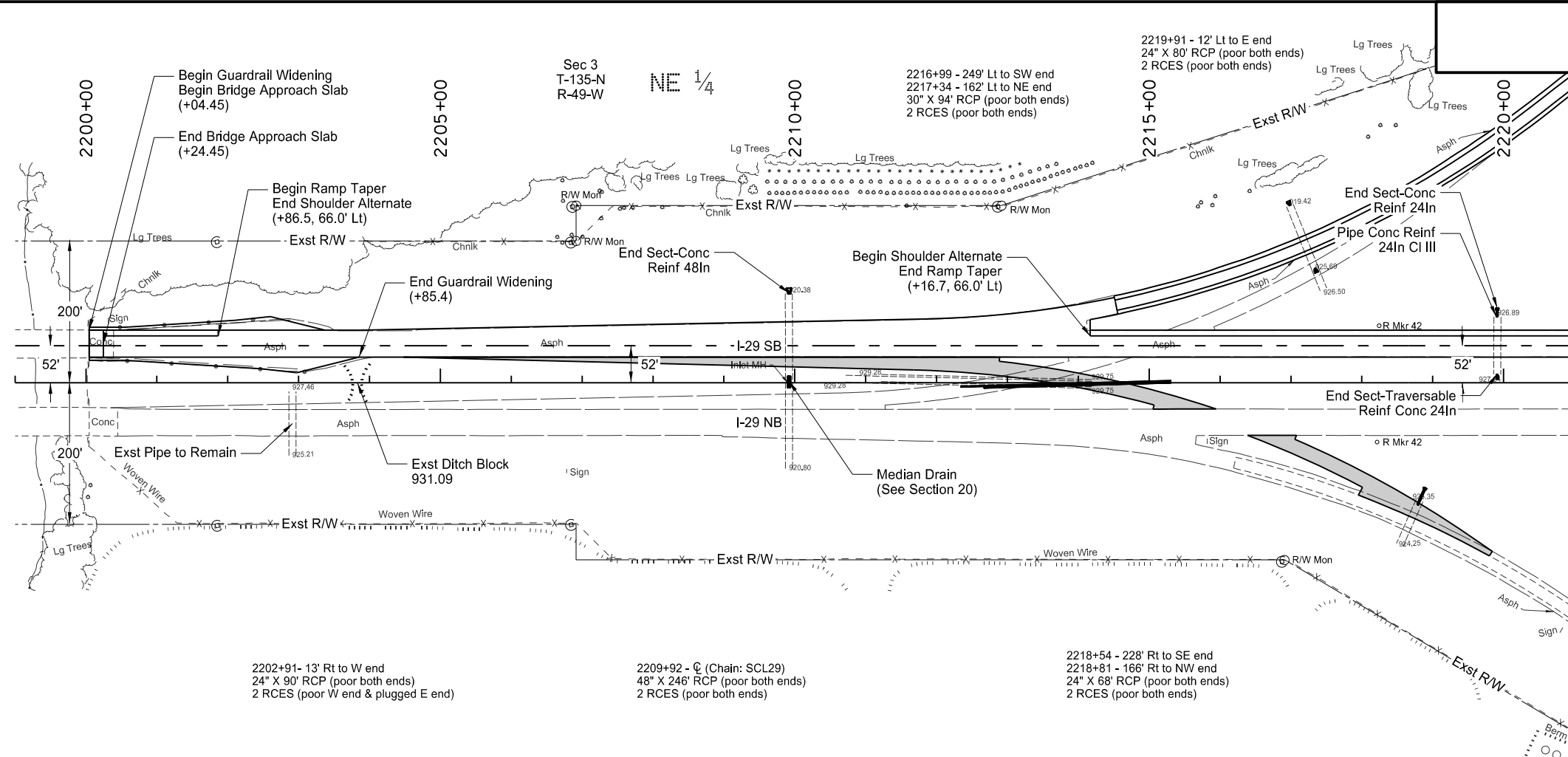

SPEC	CODE	BID ITEM	QTY	UNIT
714	0615	PIPE CONC REINF 24IN CL III Sta 2219+91 ~ 93.1' Lt to Sta 2219+91 ~ 99.1' Lt	6	LF
714	3020	END SECT-CONC REINF 24IN Sta 2219+91 ~ 99.1' Lt	1	EA
714	3023	END SECT-TRAVERSABLE REINF. CONC.24IN Sta 2219+91 ~ 11.7' Lt	1	EA
714	3045	END SECT-CONC REINF 48IN Sta 2209+92 ~ 125.5' Lt	1	EA

Notes:
1. Refer to Section 90 for pipe quantities on southbound interstate ramps.

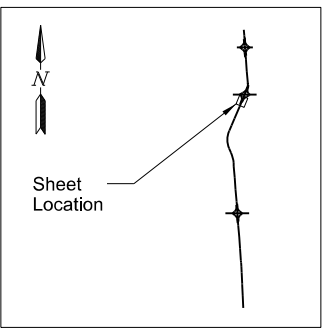
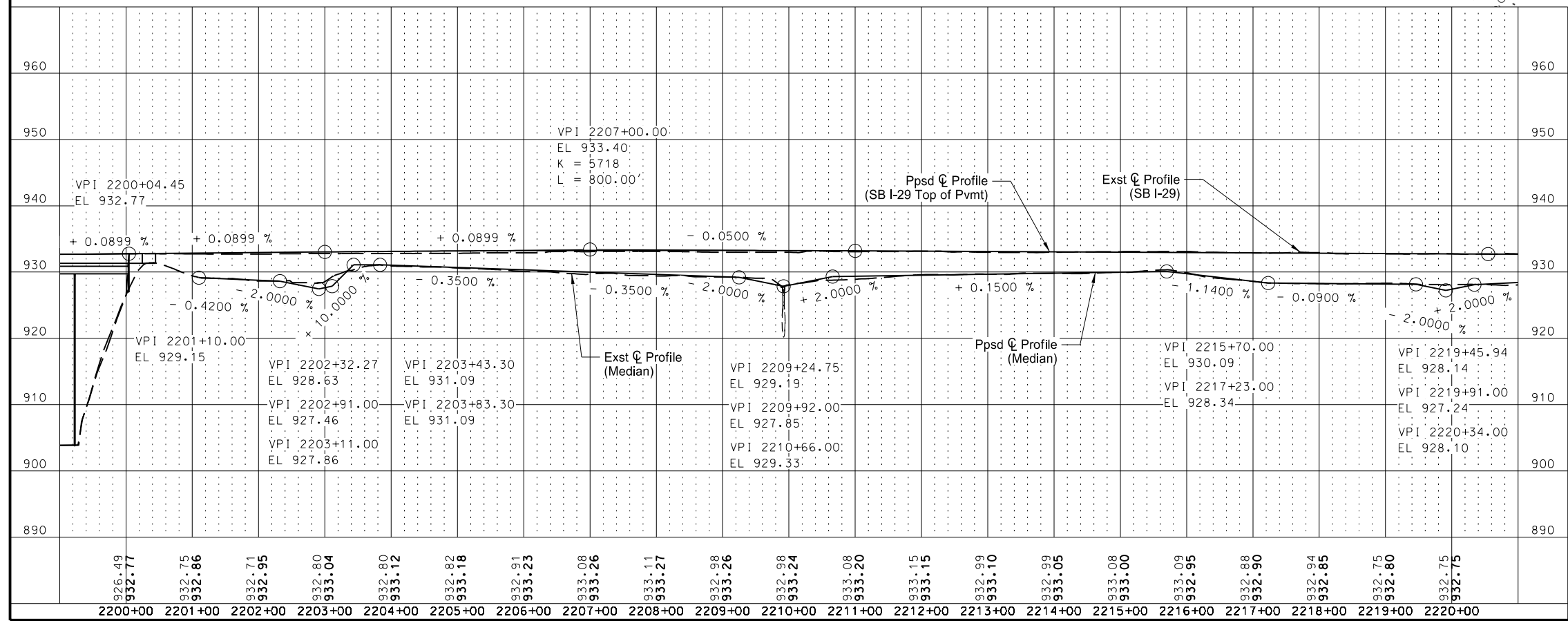

This document was originally issued and sealed by Jonathan D. Bach, Registration Number PE- 9797, on 08/07/17 and the original document is stored at the North Dakota Department of Transportation

I-29 - N of Galchutt Exit to Christine Exit
Plan & Profile
Interstate 29
Sta 2200+00 to 2220+00 (SCL29)

STATE	PROJECT NO.	SECTION NO.	SHEET NO.
ND	IM-8-029(170)033	60	24

SPEC	CODE	BID ITEM	QTY	UNIT
714	0615	PIPE CONC REINF 24IN CL III Sta 2229+91 ~ 92.0' Lt to Sta 2229+91 ~ 98.0' Lt	6	LF
714	3020	END SECT-CONC REINF 24IN Sta 2229+91 ~ 98.0' Lt	1	EA
714	3023	END SECT-TRAVERSABLE REINF. CONC.24IN Sta 2229+91 ~ 10.9' Lt	1	EA

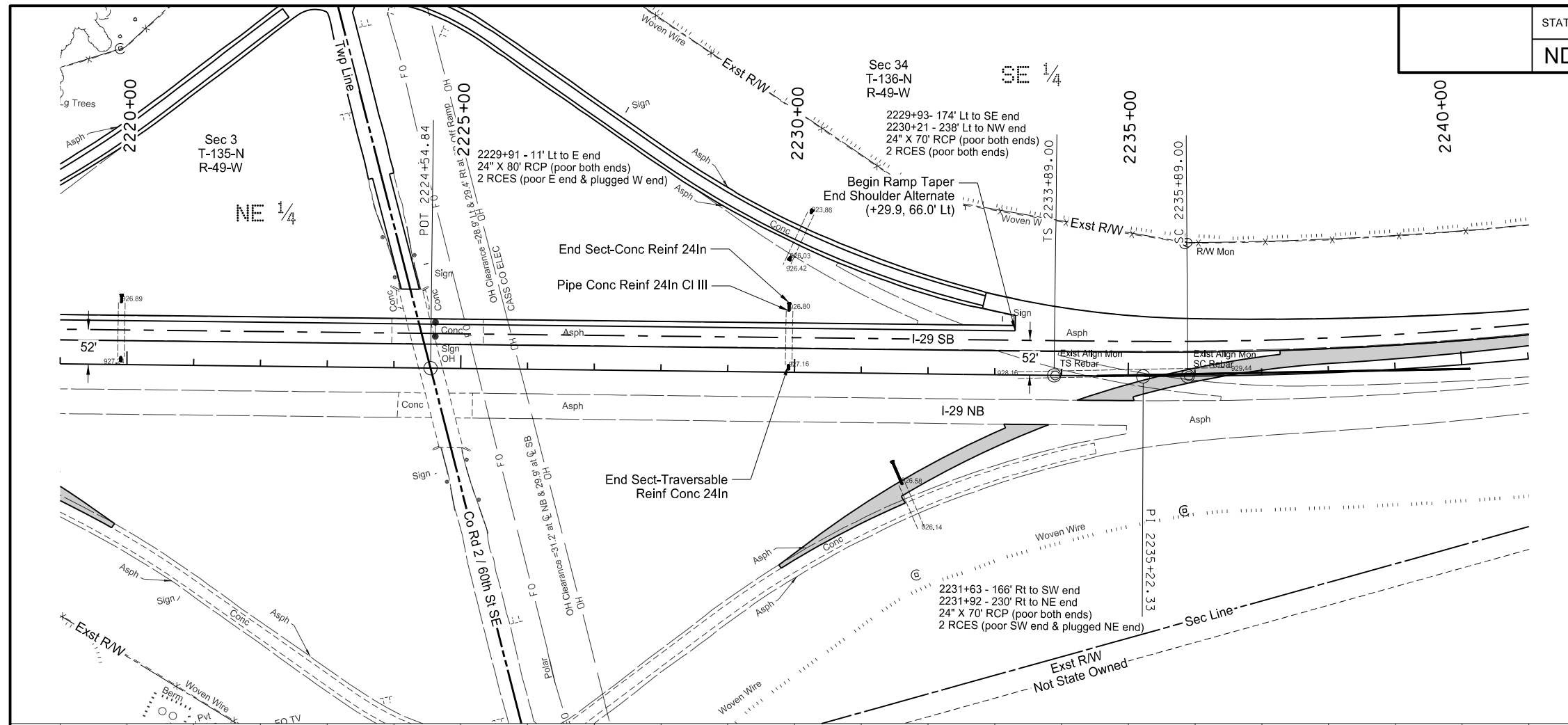

Notes:
1. Refer to Section 90 for pipe quantities on southbound interstate ramps.

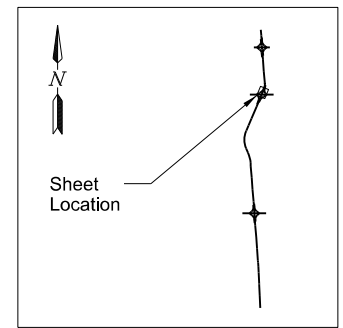
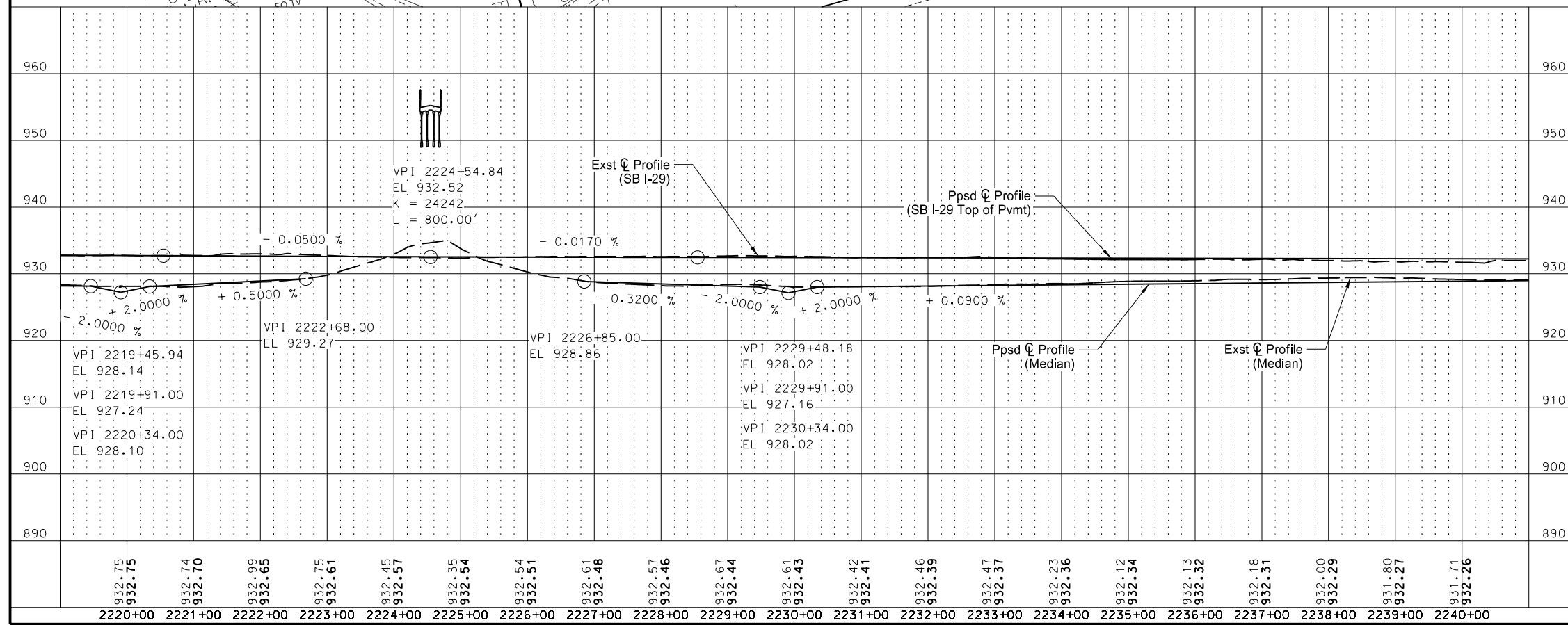

This document was originally issued and sealed by Jonathan D. Bach, Registration Number PE- 9797, on 08/07/17 and the original document is stored at the North Dakota Department of Transportation

I-29 - N of Galchutt Exit to Christine Exit
Plan & Profile
Interstate 29
Sta 2220+00 to 2240+00 (SCL29)

STATE	PROJECT NO.	SECTION NO.	SHEET NO.
ND	IM-8-029(170)033	60	25

SPEC	CODE	BID ITEM	QTY	UNIT
714	1005	PIPE CONC REINF 42IN CL III Sta 2245+90 ~ 91.4' Lt to Sta 2245+90 ~ 97.4' Lt	6	LF
714	3020	END SECT-CONC REINF 24IN Sta 2254+91 ~ 98.7' Lt	1	EA
714	3023	END SECT-TRAVERSABLE REINF. CONC.24IN Sta 2254+91 ~ 11.3' Lt	1	EA
714	3040	END SECT-CONC REINF 42IN Sta 2245+90 ~ 97.4' Lt	1	EA

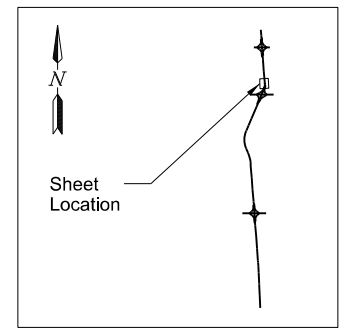
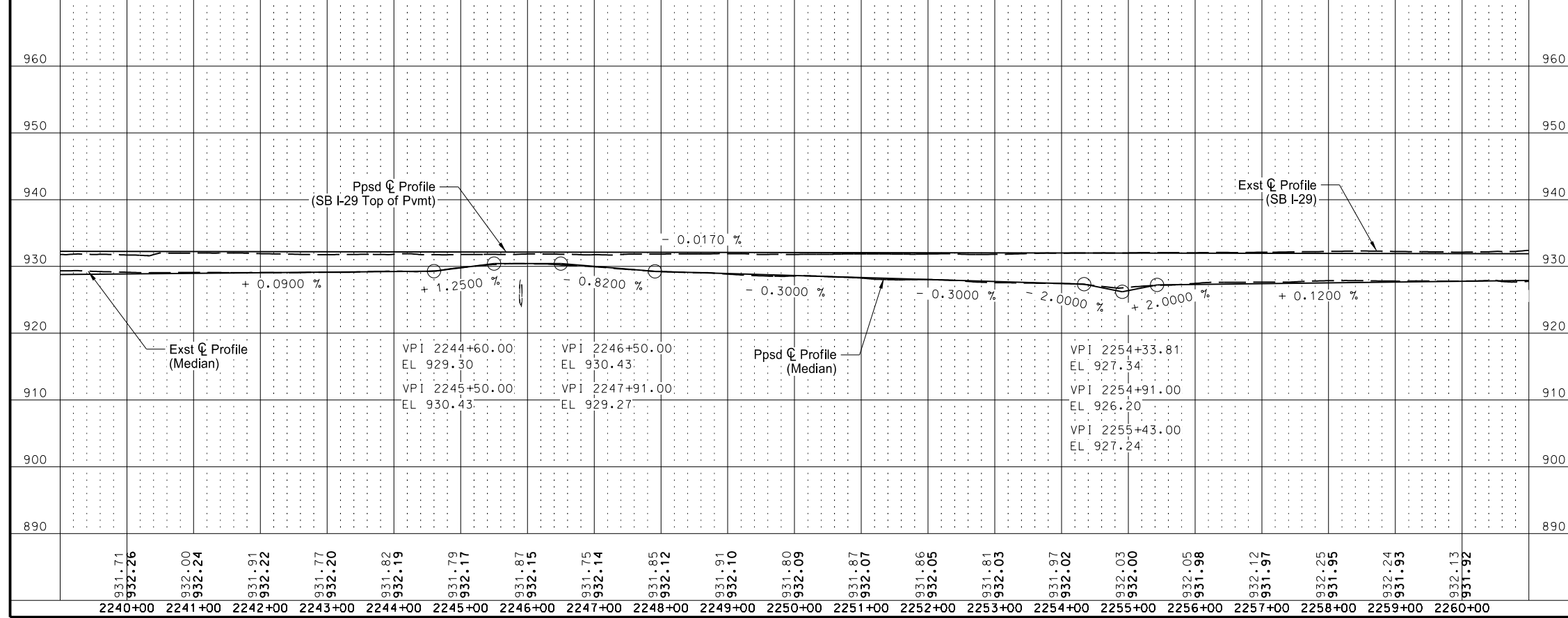
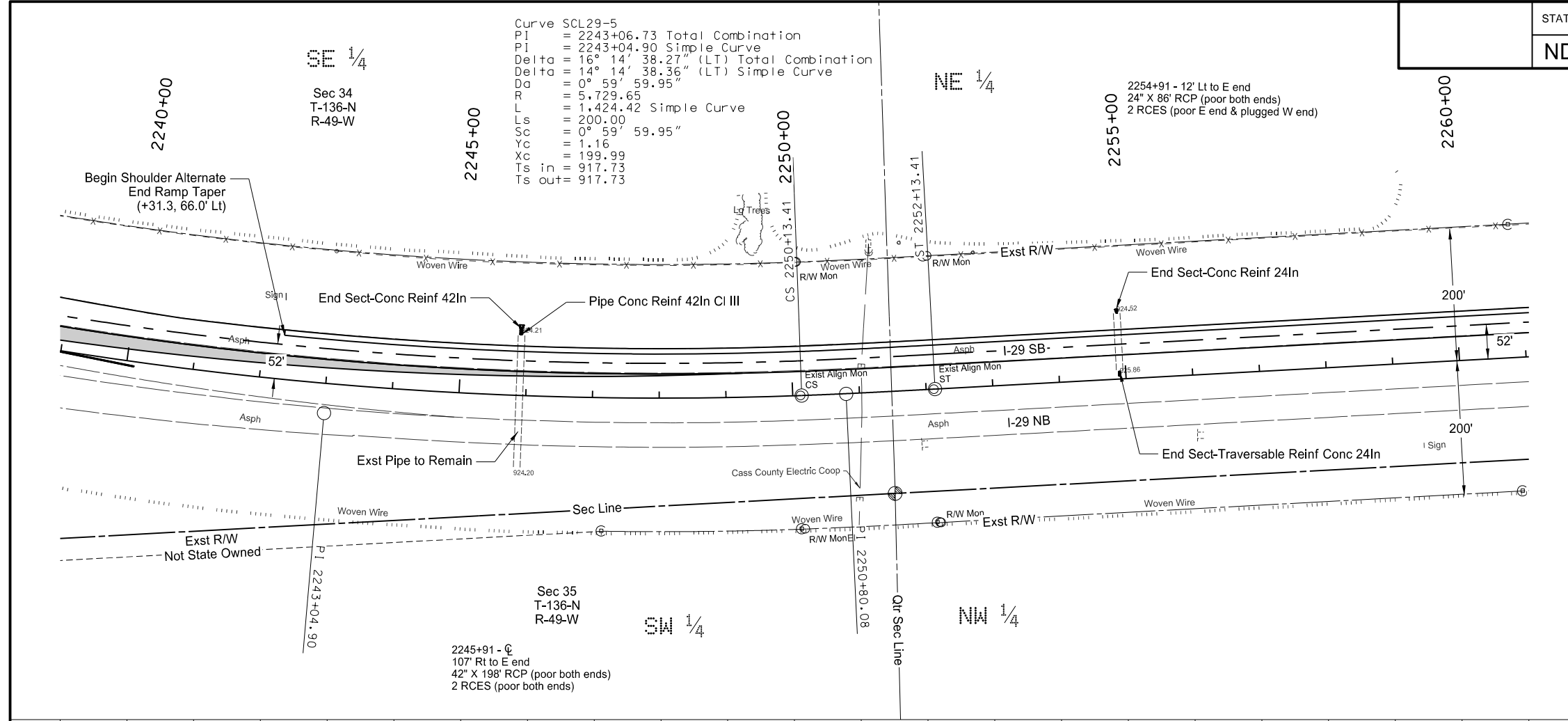

This document was originally issued and sealed by Jonathan D. Bach, Registration Number PE- 9797, on 08/07/17 and the original document is stored at the North Dakota Department of Transportation

I-29 - N of Galchutt Exit to Christine Exit
 Plan & Profile
 Interstate 29
 Sta 2240+00 to 2260+00 (SCL29)

STATE	PROJECT NO.	SECTION NO.	SHEET NO.
ND	IM-8-029(170)033	60	26

SPEC	CODE	BID ITEM	QTY	UNIT
714	0615	PIPE CONC REINF 24IN CL III Sta 2277+90 ~ 91.9' Lt to Sta 2277+90 ~ 97.9' Lt	6	LF
714	3020	END SECT-CONC REINF 24IN Sta 2277+90 ~ 97.9' Lt	1	EA
714	3023	END SECT-TRAVERSABLE REINF. CONC.24IN Sta 2277+90 ~ 11.1' Lt	1	EA
714	9659	REMOVE & RELAY PIPE-ALL TYPES & SIZES Sta 2277+90 ~ 11.1' Lt to Sta 2277+90 ~ 27.1' Lt	16	LF

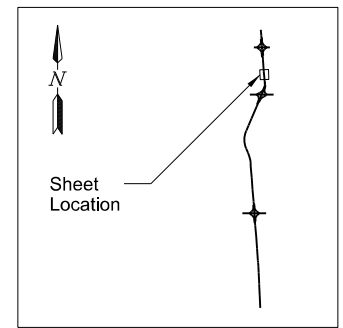
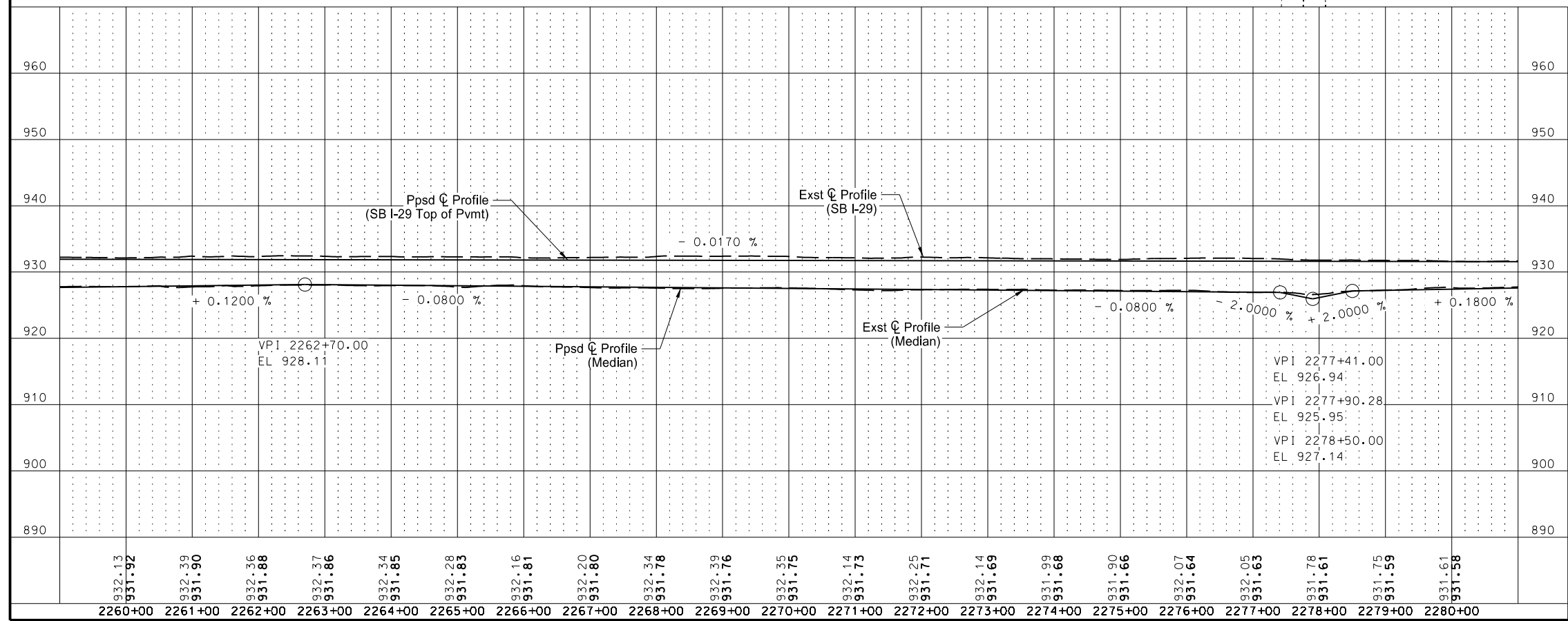
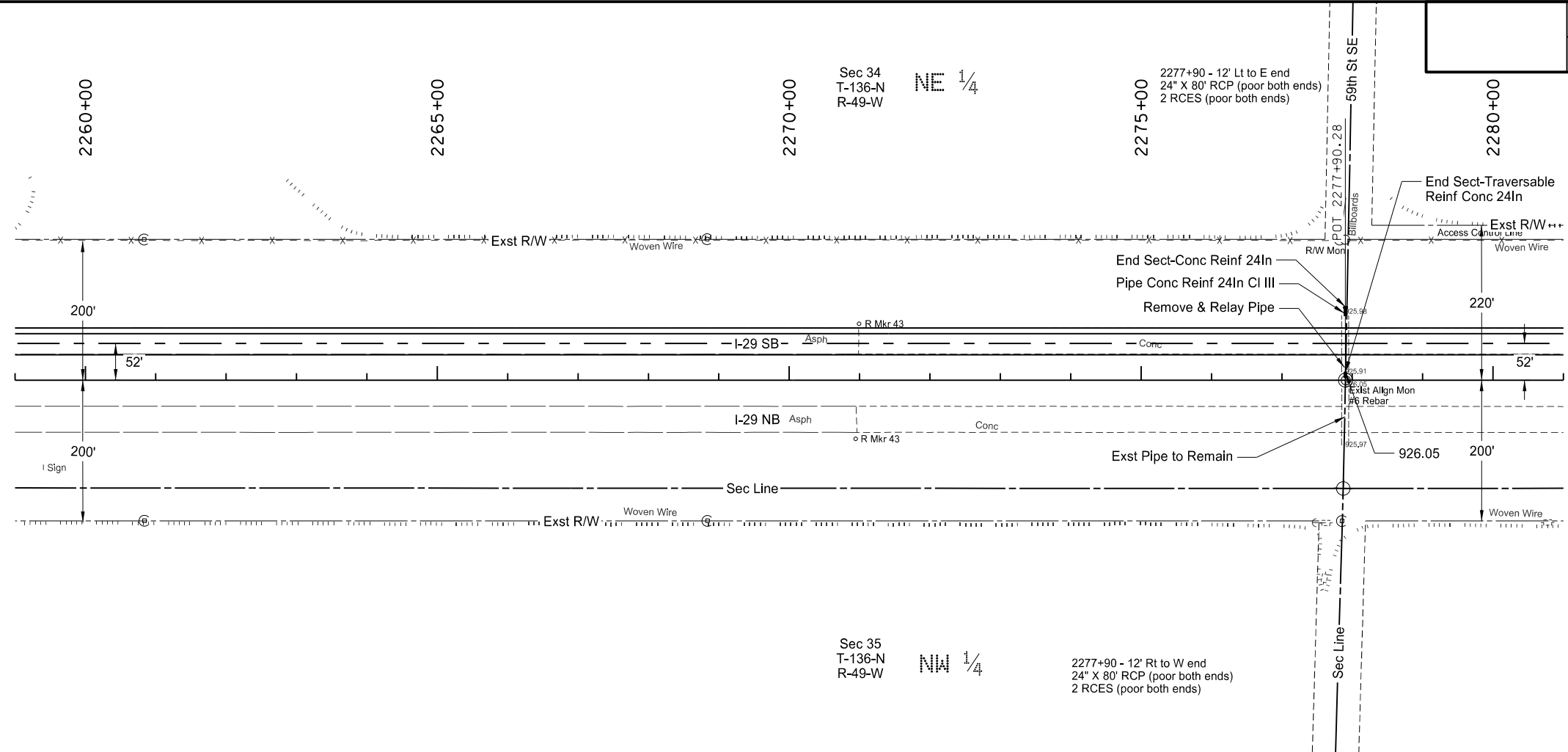

This document was originally issued and sealed by Jonathan D. Bach, Registration Number PE- 9797, on 08/07/17 and the original document is stored at the North Dakota Department of Transportation

I-29 - N of Galchutt Exit to Christine Exit
Plan & Profile
Interstate 29
Sta 2260+00 to 2280+00 (SCL29)

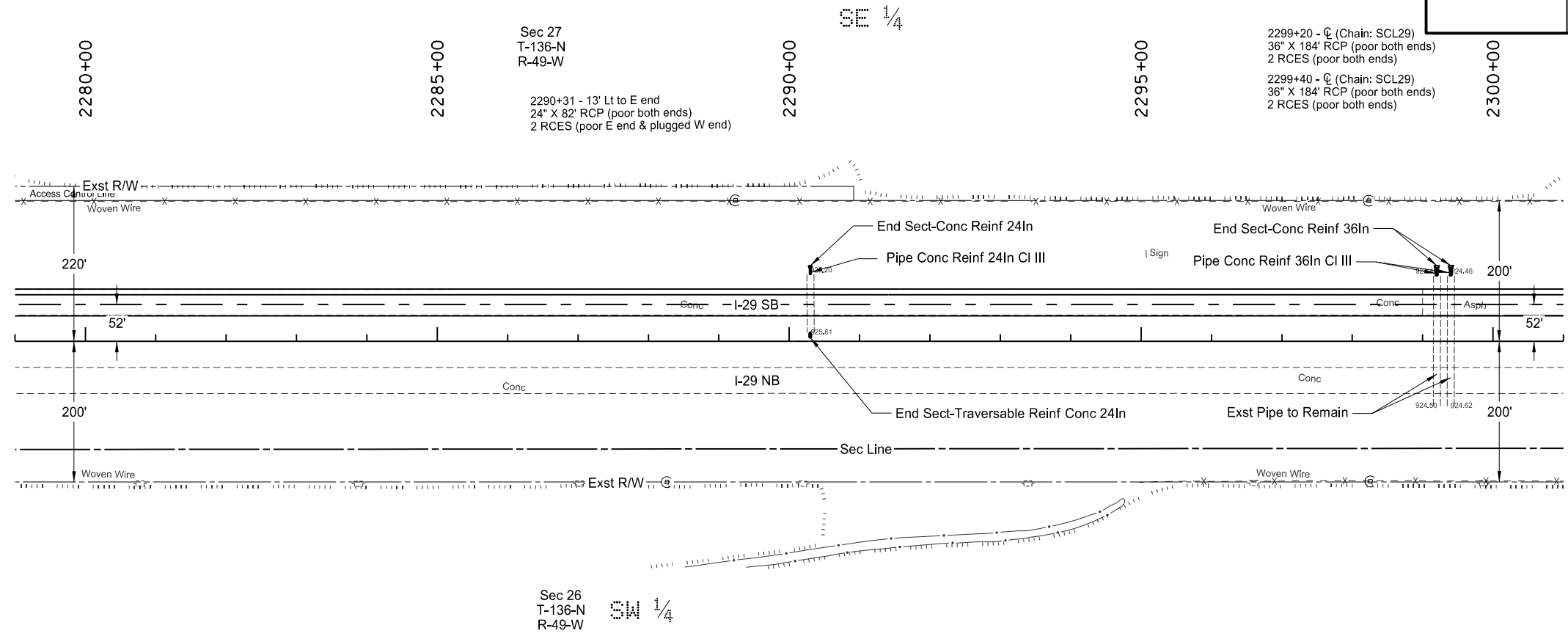

SPEC	CODE	BID ITEM	QTY	UNIT
714	0615	PIPE CONC REINF 24IN CL III Sta 2290+30 ~ 95.0' Lt to Sta 2290+30 ~ 101.0' Lt	6	LF
714	0905	PIPE CONC REINF 36IN CL III Sta 2299+20 ~ 93.3' Lt to Sta 2299+20 ~ 99.3' Lt Sta 2299+40 ~ 93.3' Lt to Sta 2299+40 ~ 99.3' Lt	6	LF
714	3020	END SECT-CONC REINF 24IN Sta 2290+30 ~ 101.0' Lt	1	EA
714	3023	END SECT-TRAVERSABLE REINF. CONC.24IN Sta 2290+30 ~ 12.1' Lt	1	EA
714	3035	END SECT-CONC REINF 36IN Sta 2299+20 ~ 93.3' Lt Sta 2299+40 ~ 93.3' Lt	1	EA

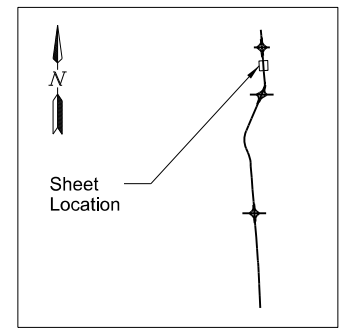
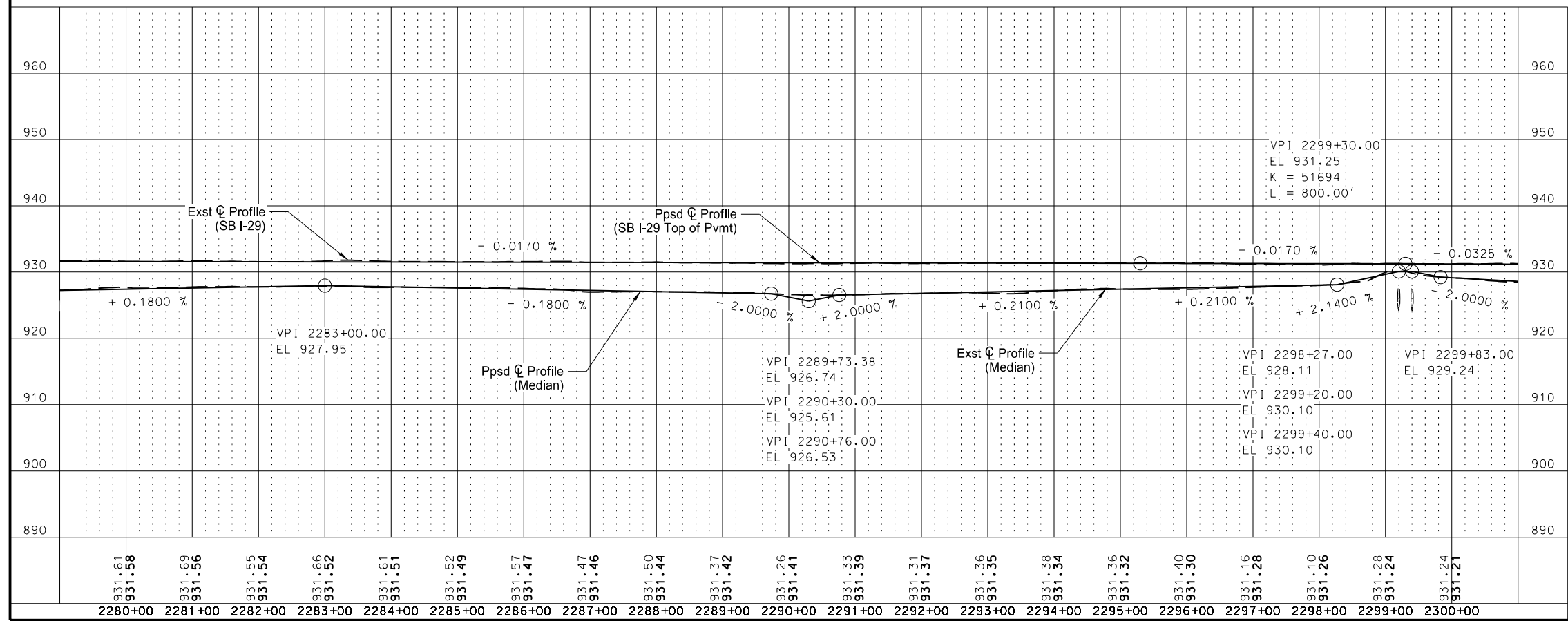

This document was originally issued and sealed by Jonathan D. Bach, Registration Number PE- 9797, on 08/07/17 and the original document is stored at the North Dakota Department of Transportation

I-29 - N of Galchutt Exit to Christine Exit
Plan & Profile
Interstate 29
Sta 2280+00 to 2300+00 (SCL29)

STATE	PROJECT NO.	SECTION NO.	SHEET NO.
ND	IM-8-029(170)033	60	28

SPEC	CODE	BID ITEM	QTY	UNIT
714	0615	PIPE CONC REINF 24IN CL III Sta 2312+32 ~ 93.6' Lt to Sta 2312+32 ~ 99.6' Lt	6	LF
714	3020	END SECT-CONC REINF 24IN Sta 2312+32 ~ 93.6' Lt	1	EA
714	3023	END SECT-TRAVERSABLE REINF. CONC.24IN Sta 2312+32 ~ 12.5' Lt	1	EA

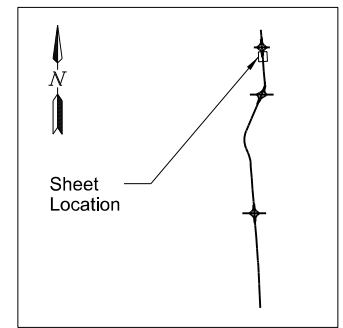
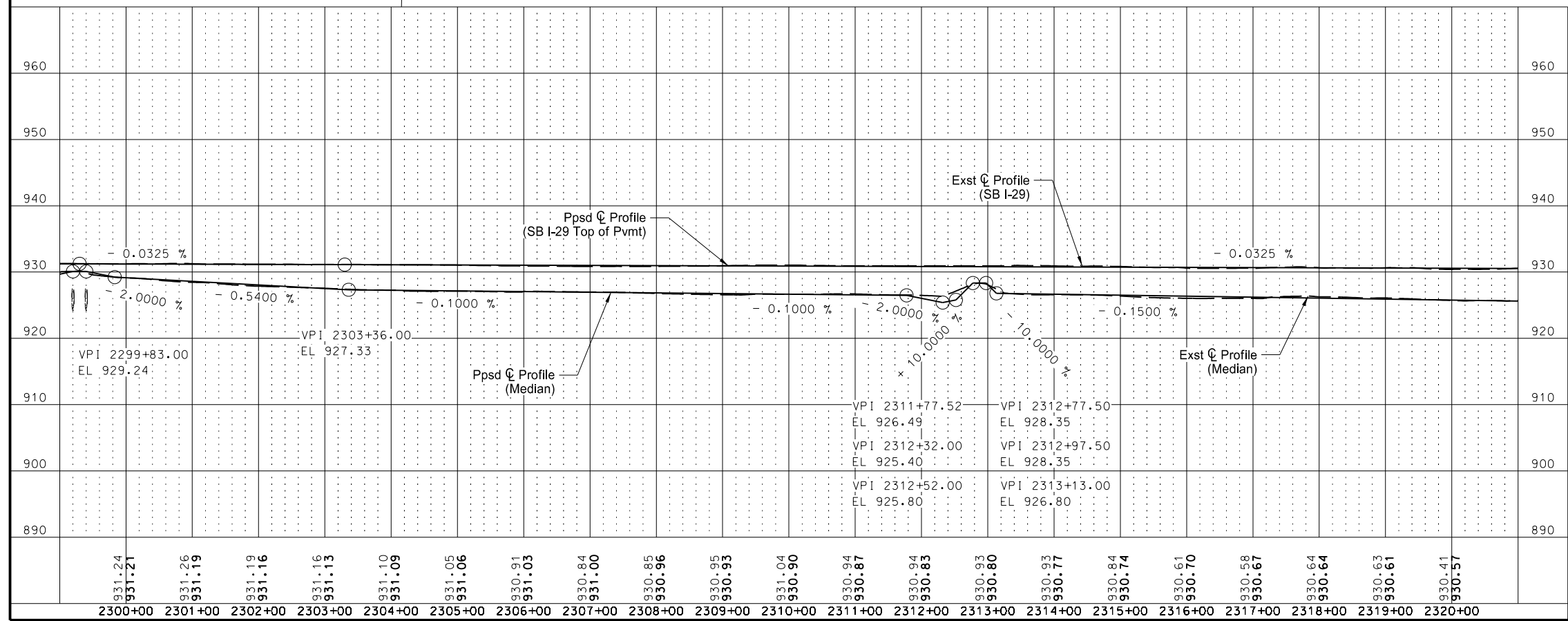
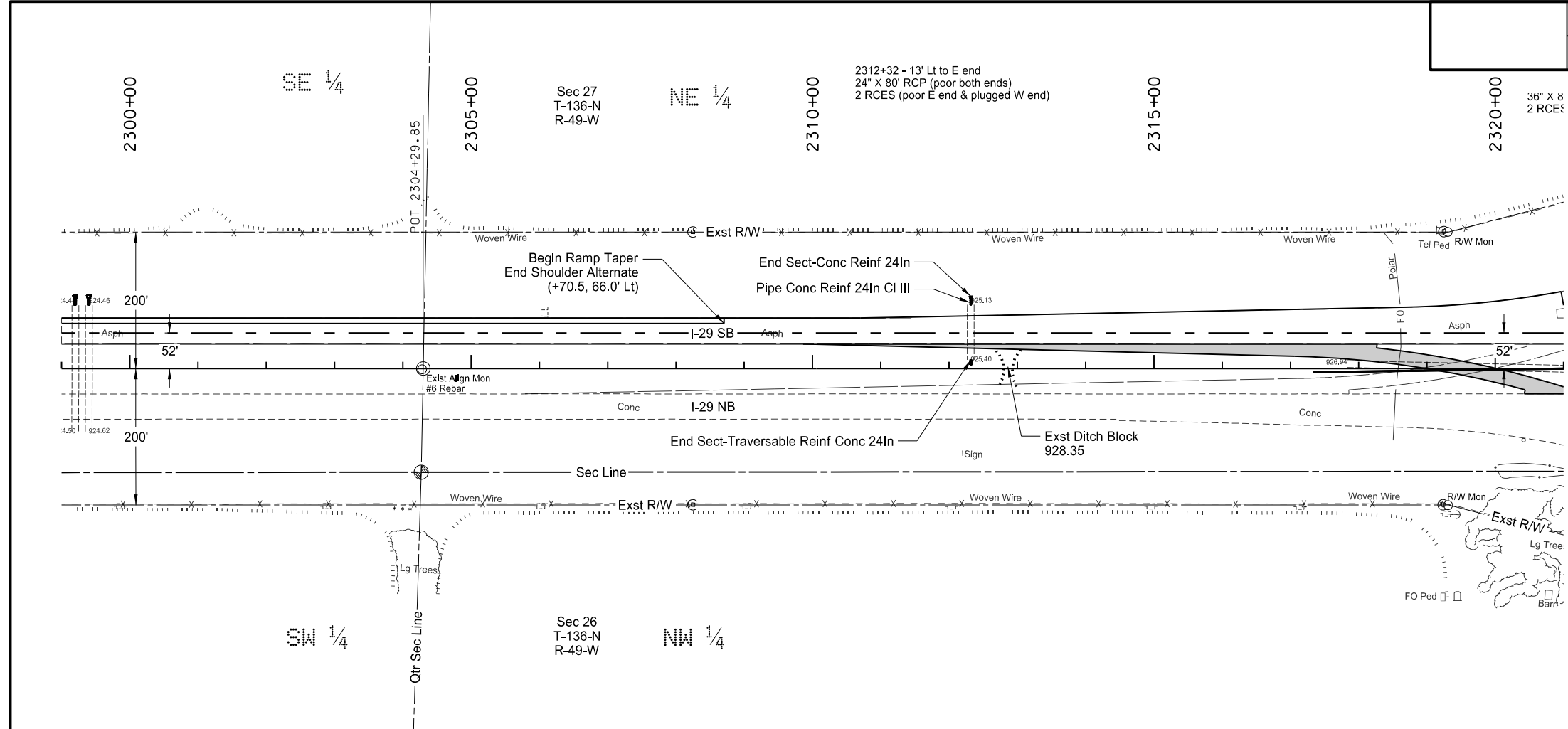

This document was originally issued and sealed by Jonathan D. Bach, Registration Number PE- 9797, on 08/07/17 and the original document is stored at the North Dakota Department of Transportation

I-29 - N of Galchutt Exit to Christine Exit
Plan & Profile
Interstate 29
Sta 2300+00 to 2320+00 (SCL29)

STATE	PROJECT NO.	SECTION NO.	SHEET NO.
ND	IM-8-029(170)033	60	29

SPEC	CODE	BID ITEM	QTY	UNIT
714	3020	END SECT-CONC REINF 24IN Sta 2324+31 ~ 98.8' Lt	1	EA
714	3023	END SECT-TRAVERSABLE REINF. CONC.24IN Sta 2324+31 ~ 12.7' Lt	1	EA
714	3035	END SECT-CONC REINF 36IN Sta 2325+80 ~ 99.1' Lt	1	EA

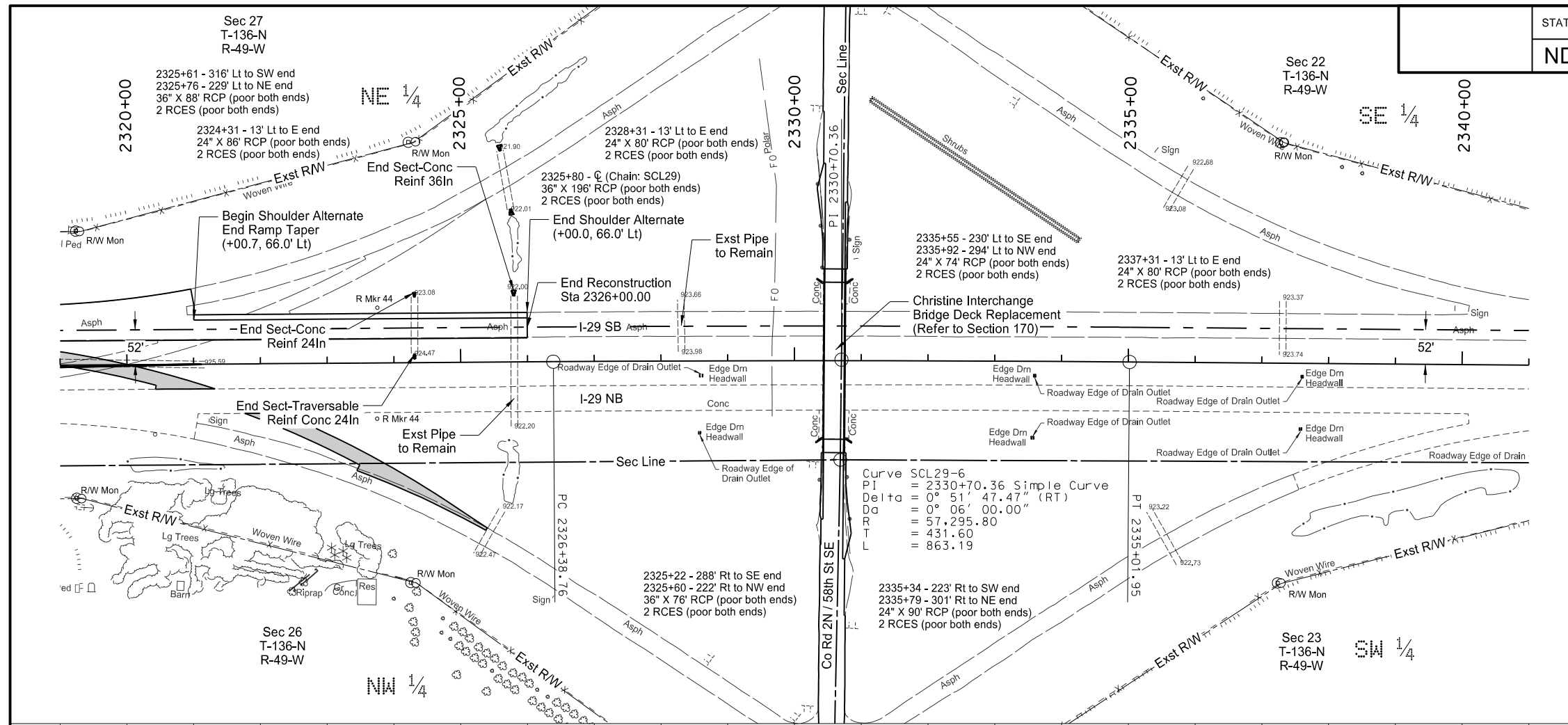

Curve SCL29-6
 PI = 2330+70.36 Simple Curve
 Delta = 0° 51' 47.47" (RT)
 Da = 0° 06' 00.00"
 R = 57.295.80
 T = 431.60
 L = 863.19

Notes:
 1. Refer to Section 90 for pipe quantities on southbound interstate ramps.

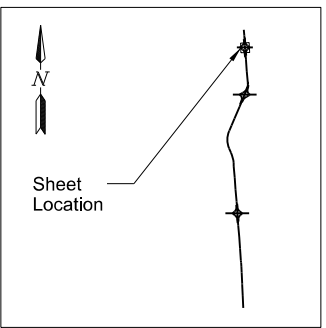
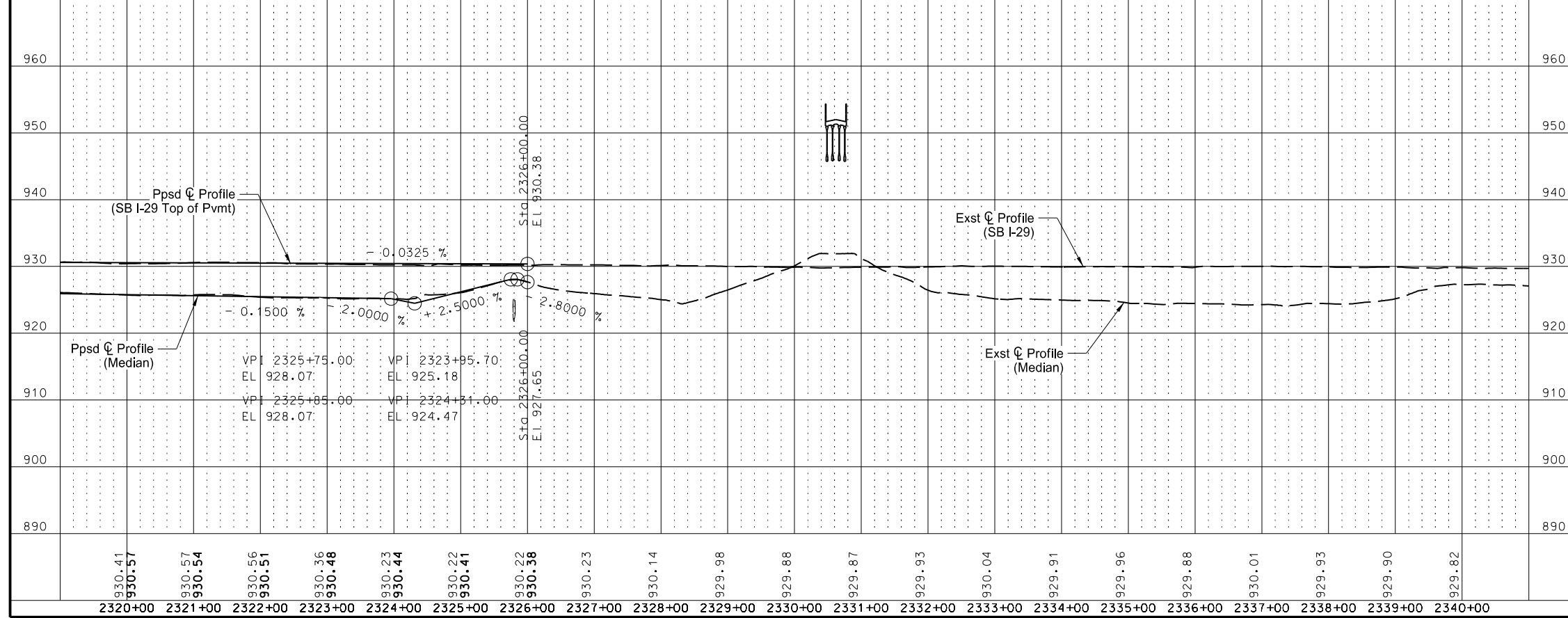

This document was originally issued and sealed by Jonathan D. Bach, Registration Number PE- 9797, on 08/07/17 and the original document is stored at the North Dakota Department of Transportation

I-29 - N of Galchutt Exit to Christine Exit
 Plan & Profile
 Interstate 29
 Sta 2320+00 to 2340+00 (SCL29)

STATE	PROJECT NO.	SECTION NO.	SHEET NO.
ND	IM-8-029(170)033	60	30

SPEC	CODE	BID ITEM	QTY	UNIT
714	9659	REMOVE & RELAY PIPE-ALL TYPES & SIZES		
Sta 108+55 ~ 21.7' Rt to Sta 110+75 ~ 29.6' Lt			226	LF

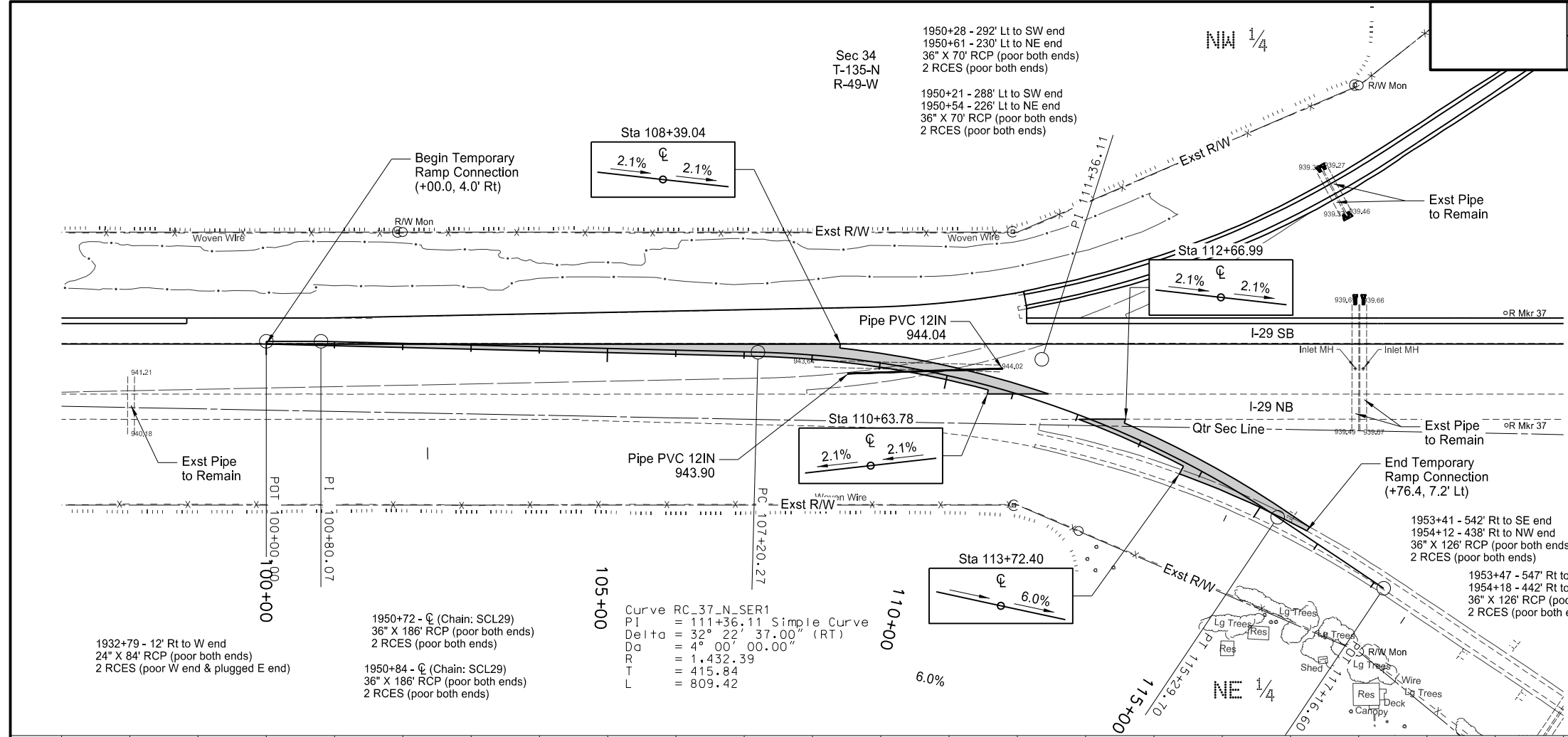

Notes:
 1. The proposed profile is controlled by the existing edge of pavement. The proposed pavement will match existing pavement elevations at the tie points.

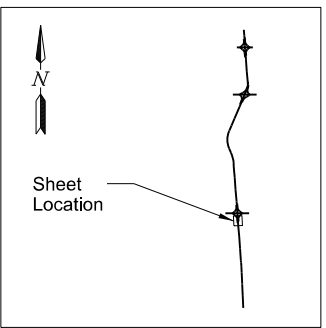
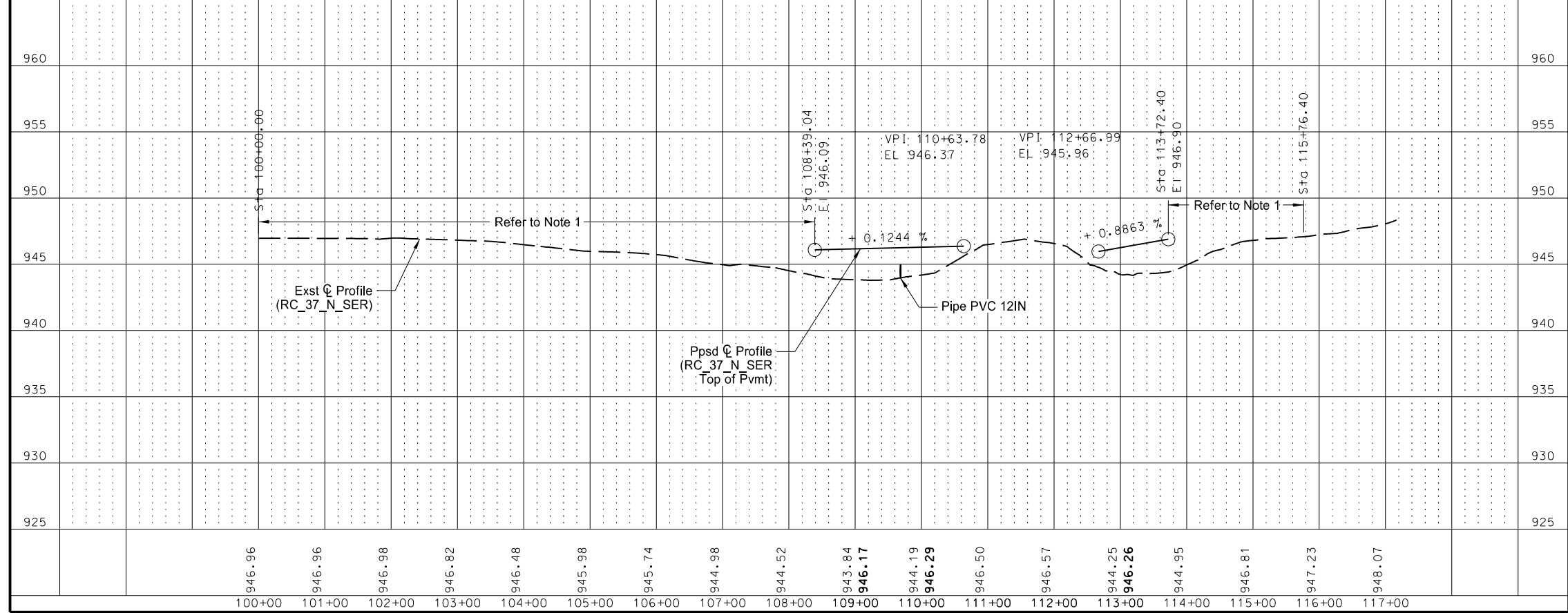

This document was originally issued and sealed by Jonathan D. Bach, Registration Number PE- 9797, on 08/07/17 and the original document is stored at the North Dakota Department of Transportation

I-29 - N of Galchutt Exit to Christine Exit
 Plan & Profile
 Colfax Interchange Southeast Ramp Connection
 Sta 100+00 to 115+76 (RC_37_N_SER)

STATE	PROJECT NO.	SECTION NO.	SHEET NO.
ND	IM-8-029(170)033	60	31

SPEC	CODE	BID ITEM	QTY	UNIT
714	7030	PIPE PVC 12IN		
		Sta 209+14 ~ 22.8' Rt to Sta 209+44 ~ 25.5' Rt	30	LF
714	9659	REMOVE & RELAY PIPE-ALL TYPES & SIZES		
		Sta 206+33 ~ 33.4' Lt to Sta 209+14 ~ 22.8' Rt	287	LF

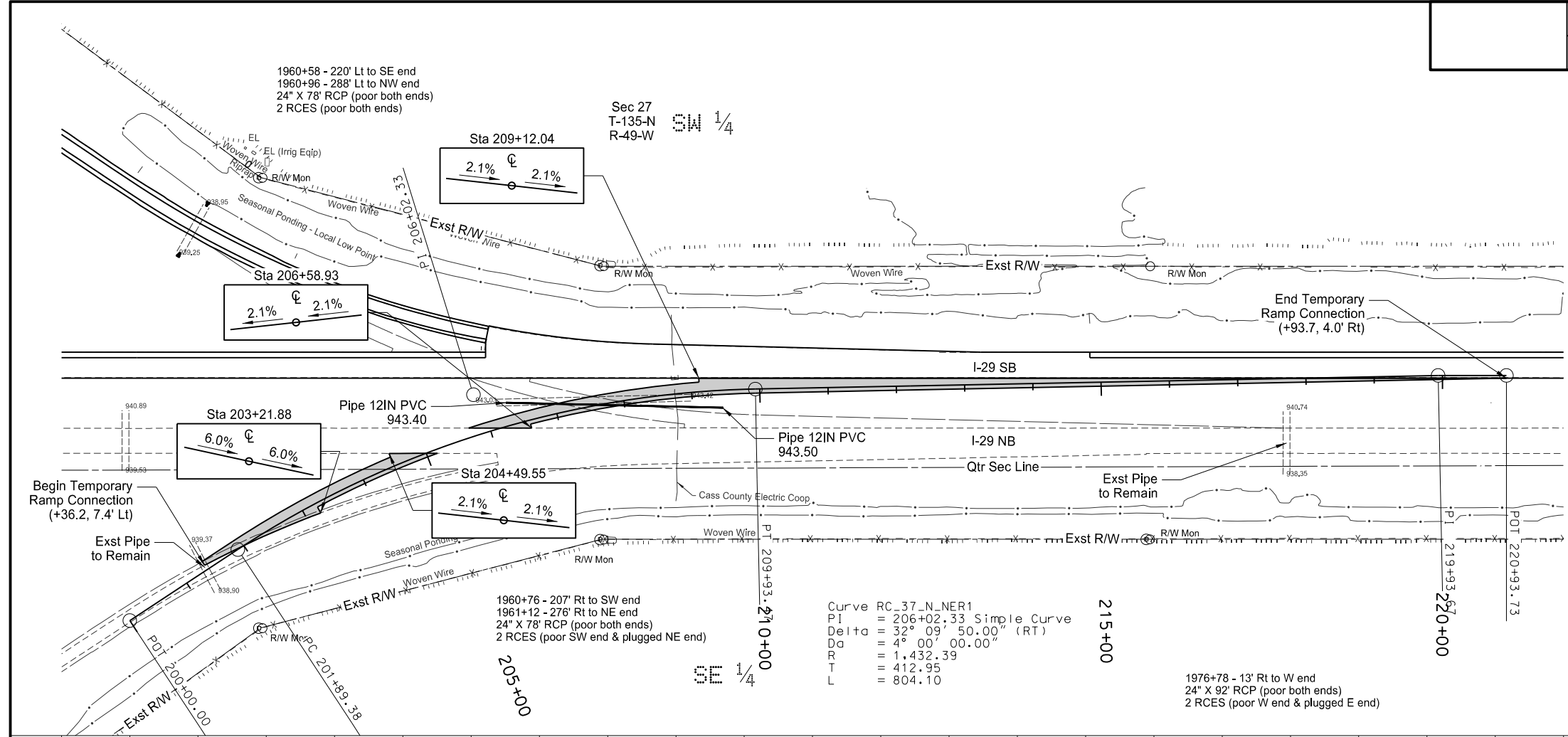

Notes:
 1. The proposed profile is controlled by the existing edge of pavement. The proposed pavement will match existing pavement elevations at the tie points.

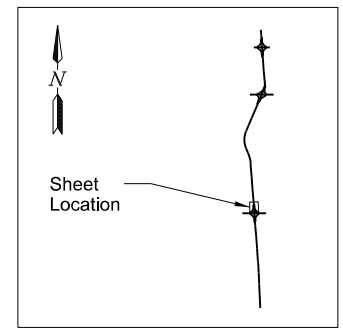
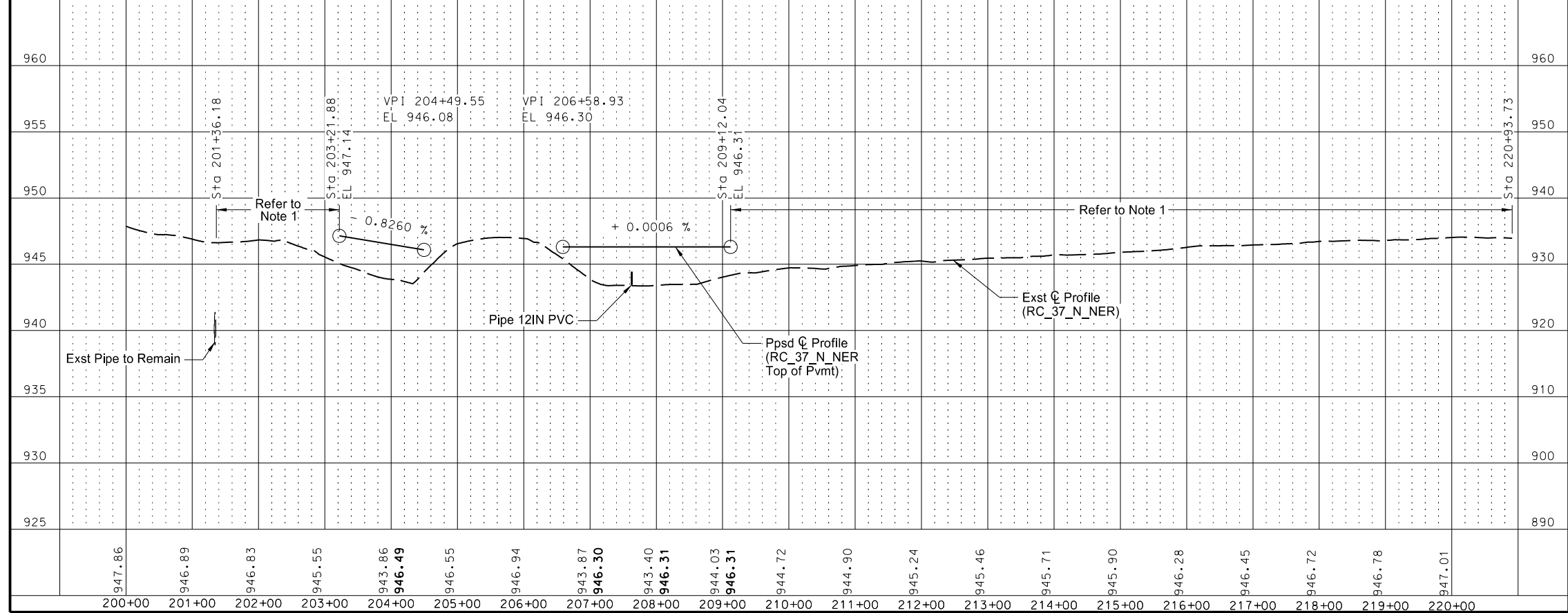

This document was originally issued and sealed by Jonathan D. Bach, Registration Number PE- 9797, on 08/07/17 and the original document is stored at the North Dakota Department of Transportation

I-29 - N of Galchutt Exit to Christine Exit
 Plan & Profile
 Coflax Interchange Northeast Ramp Connection
 Sta 201+36 to 220+94 (RC_37_N_NER)

STATE	PROJECT NO.	SECTION NO.	SHEET NO.
ND	IM-8-029(170)033	60	32

SPEC	CODE	BID ITEM	QTY	UNIT
714	0615	PIPE CONC REINF 24IN CL III	20	LF
Sta 314+63 ~ 11.3' Lt to Sta 314+60 ~ 31.0' Lt				
714	3020	END SECT-CONC REINF 24IN	1	EA
Sta 314+60 ~ 31.0' Lt				
714	9659	REMOVE & RELAY PIPE-ALL TYPES & SIZES		
Sta 305+44 ~ 19.3' Rt to Sta 305+44 ~ 27.2' Rt				
Sta 305+44 ~ 27.2' Rt to Sta 305+45 ~ 35.2' Rt				
Sta 305+45 ~ 31.2' Rt				
Sta 307+88 ~ 26.4' Rt to Sta 310+78 ~ 33.0' Lt				
Sta 308+22 ~ 25.2' Rt to Sta 310+79 ~ 30.6' Lt				
722	4581	RELAY PRECAST CONCRETE MEDIAN DRAIN	1	EA
Sta 305+45 ~ 31.2' Rt				

Notes:
 1. The proposed profile is controlled by the existing edge of pavement. The proposed pavement will match existing pavement elevations at the tie points.

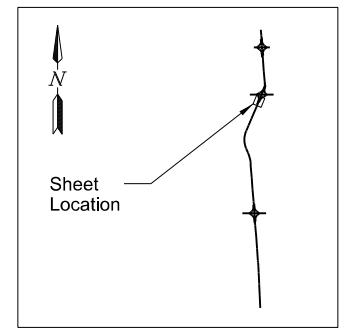

This document was originally issued and sealed by Jonathan D. Bach, Registration Number PE- 9797, on 08/07/17 and the original document is stored at the North Dakota Department of Transportation

I-29 - N of Galchutt Exit to Christine Exit
 Plan & Profile
 Walcott Interchange Southeast Ramp Connection
 Sta 300+00 to 315+86 (RC_42_N_SER)

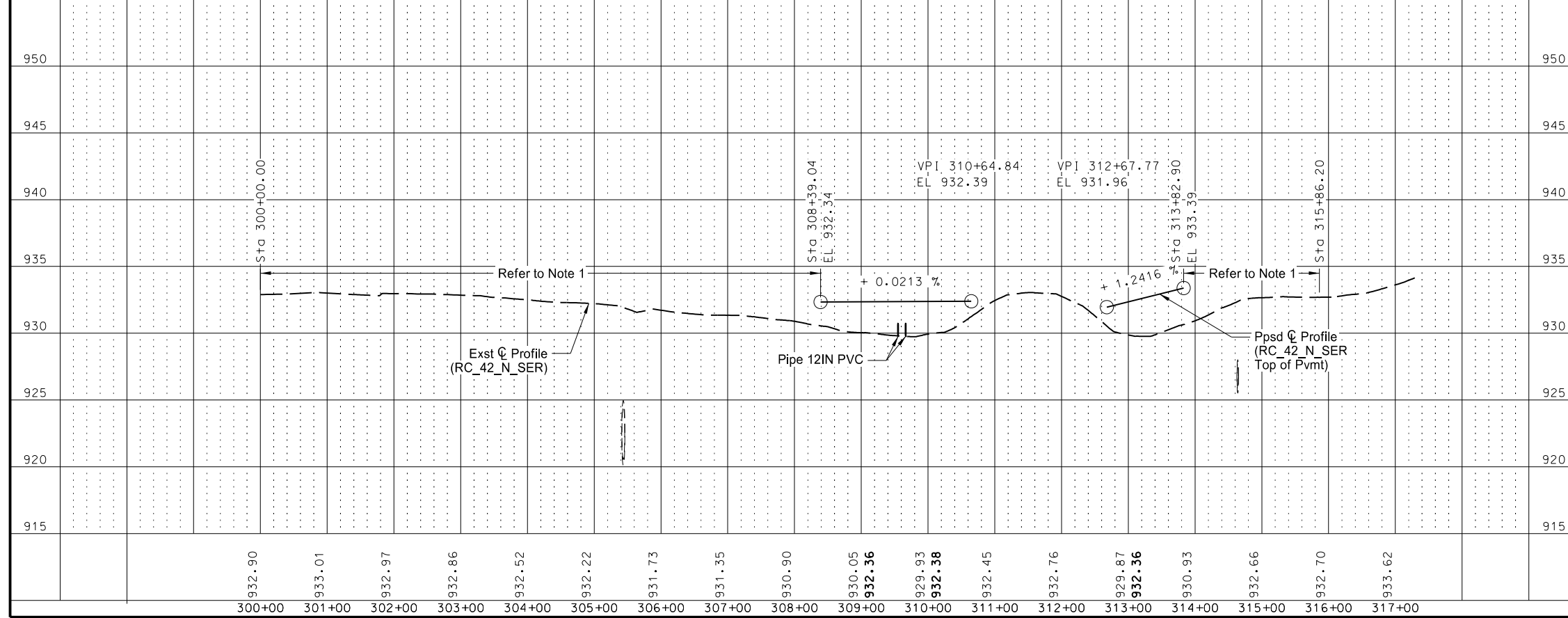
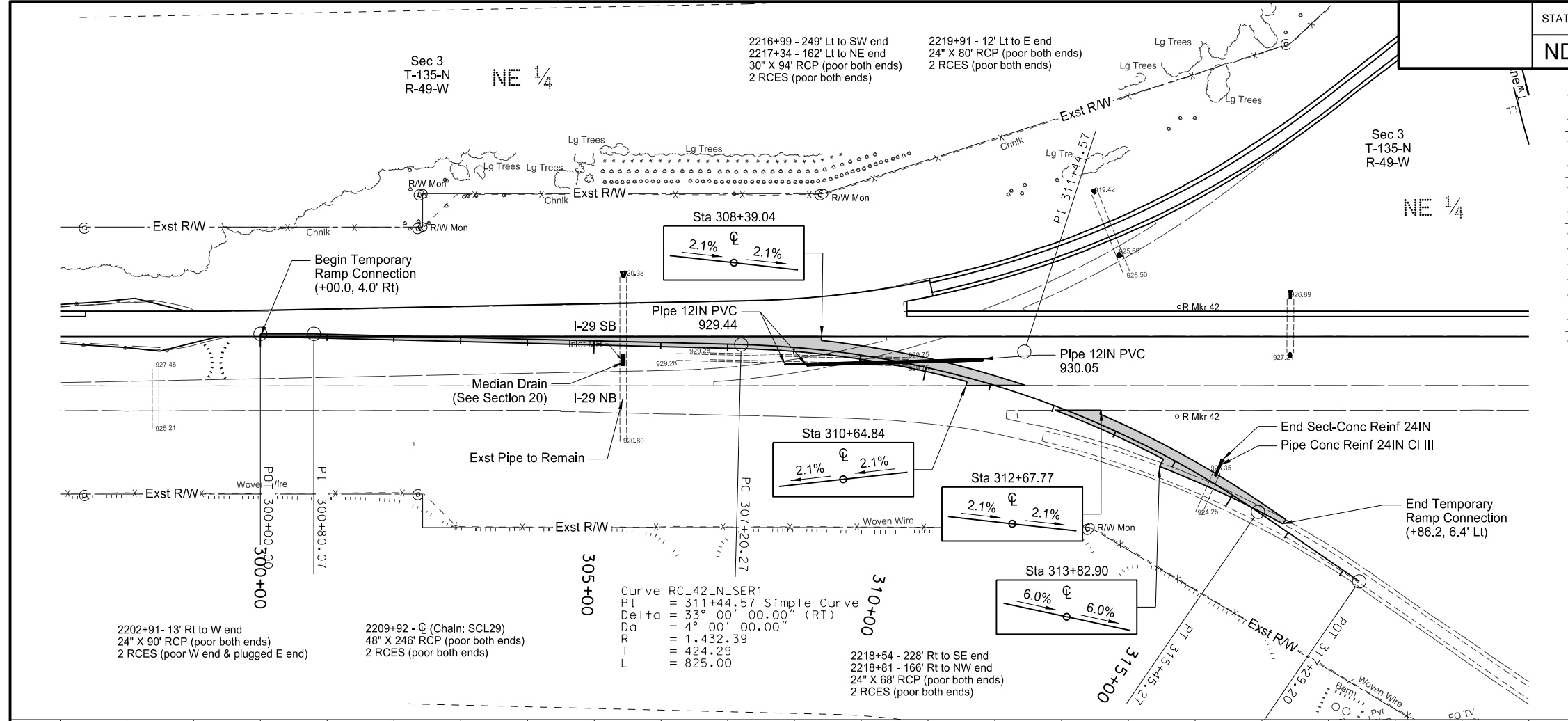

STATE	PROJECT NO.	SECTION NO.	SHEET NO.
ND	IM-8-029(170)033	60	33

SPEC	CODE	BID ITEM	QTY	UNIT
714	0615	PIPE CONC REINF 24IN CL III Sta 403+46 ~ 8.8' Lt to Sta 403+50 ~ 40.5' Lt	32	LF
714	3020	END SECT-CONC REINF 24IN Sta 403+50 ~ 40.5' Lt	1	EA
714	7030	PIPE PVC 12IN Sta 409+88 ~ 16.5' Rt to Sta 412+25 ~ 30.9' Rt	238	LF
714	9659	REMOVE & RELAY PIPE-ALL TYPES & SIZES Sta 406+74 ~ 39.3' Lt to Sta 409+88 ~ 16.5' Rt	320	LF

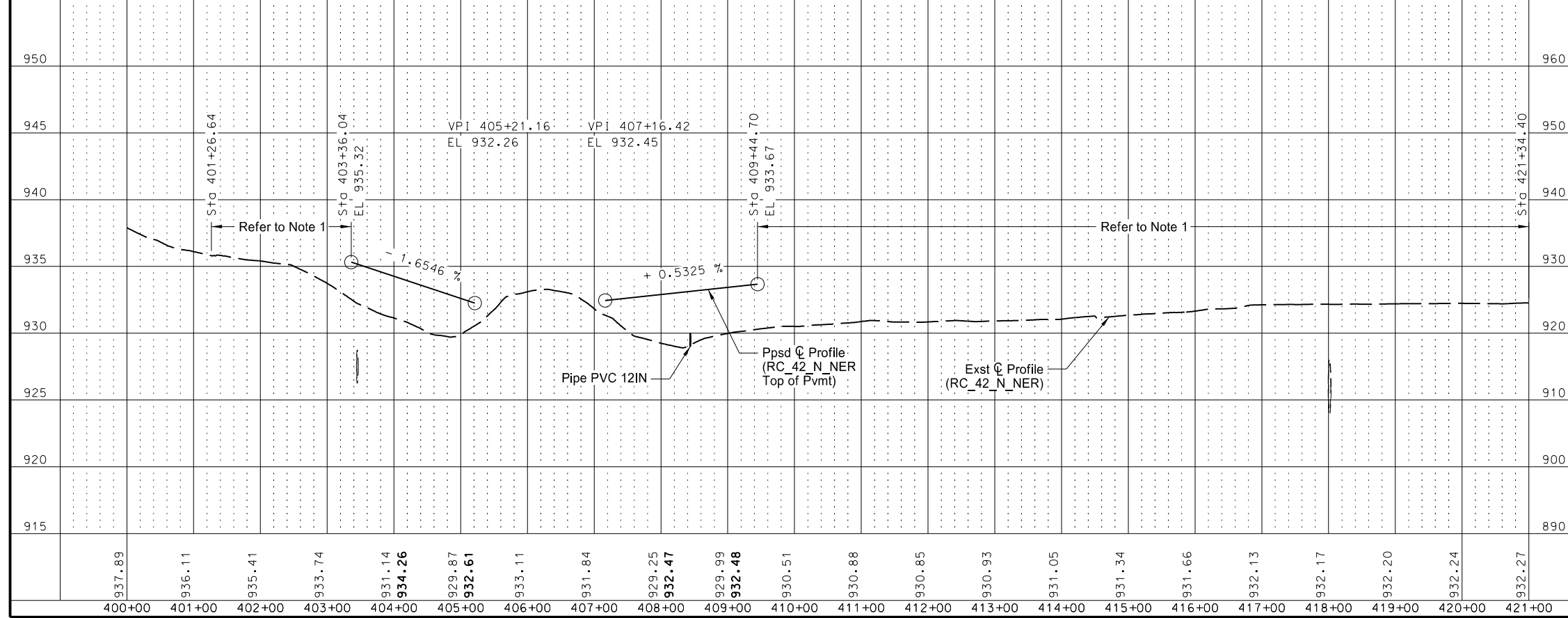
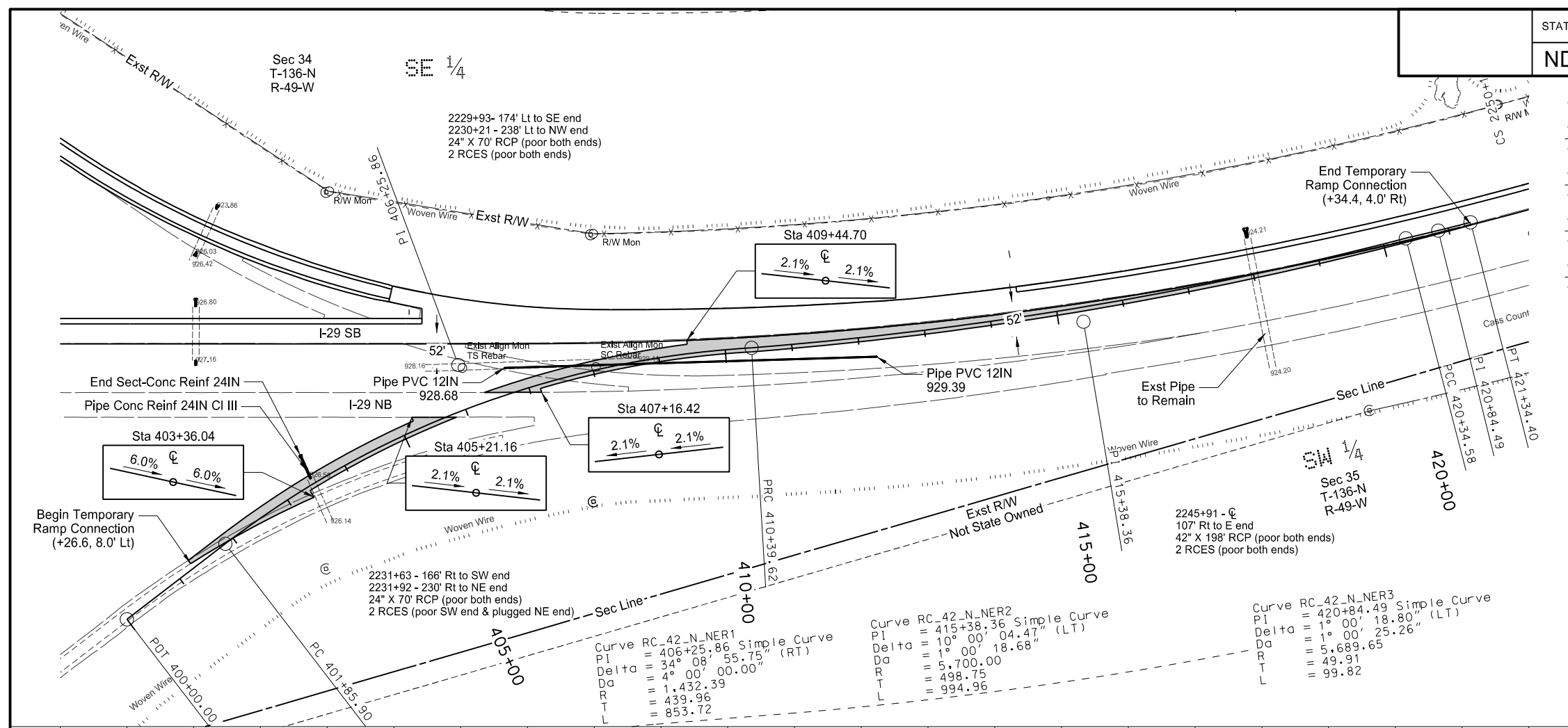

Notes:
 1. The proposed profile is controlled by the existing edge of pavement. The proposed pavement will match existing pavement elevations at the tie points.

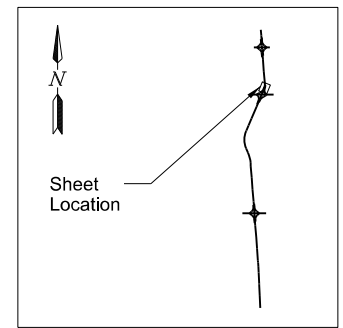

This document was originally issued and sealed by Jonathan D. Bach, Registration Number PE- 9797, on 08/07/17 and the original document is stored at the North Dakota Department of Transportation

I-29 - N of Galchutt Exit to Christine Exit
 Plan & Profile
 Walcott Interchange Northeast Ramp Connection
 Sta 401+27 to 421+34 (RC_42_N_NER)

STATE	PROJECT NO.	SECTION NO.	SHEET NO.
ND	IM-8-029(170)033	60	34

SPEC	CODE	BID ITEM	QTY	UNIT
714	7030	PIPE PVC 12IN		
		Sta 510+79 ~ 30.3' Lt to Sta 511+19 ~ 42.8' Lt	43	LF
714	9659	REMOVE & RELAY PIPE-ALL TYPES & SIZES		
		Sta 507+49 ~ 28.4' Rt to Sta 510+79 ~ 30.3' Lt	334	LF

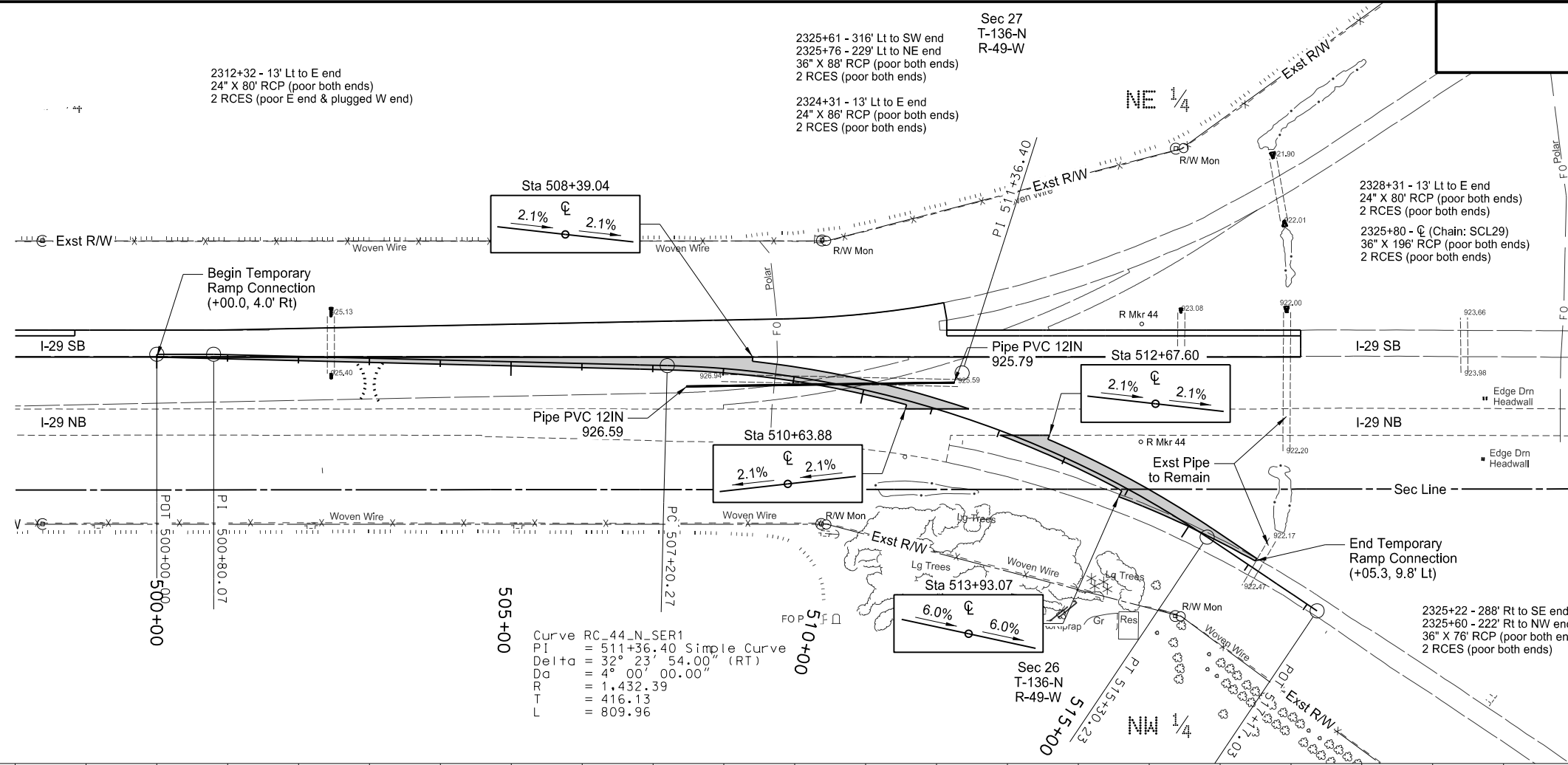

Notes:
 1. The proposed profile is controlled by the existing edge of pavement. The proposed pavement will match existing pavement elevations at the tie points.

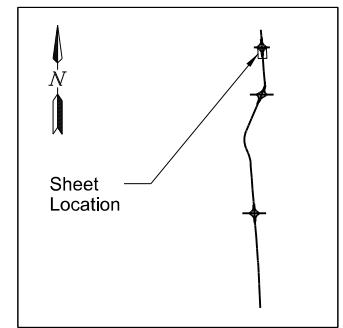

This document was originally issued and sealed by Jonathan D. Bach, Registration Number PE- 9797, on 08/07/17 and the original document is stored at the North Dakota Department of Transportation

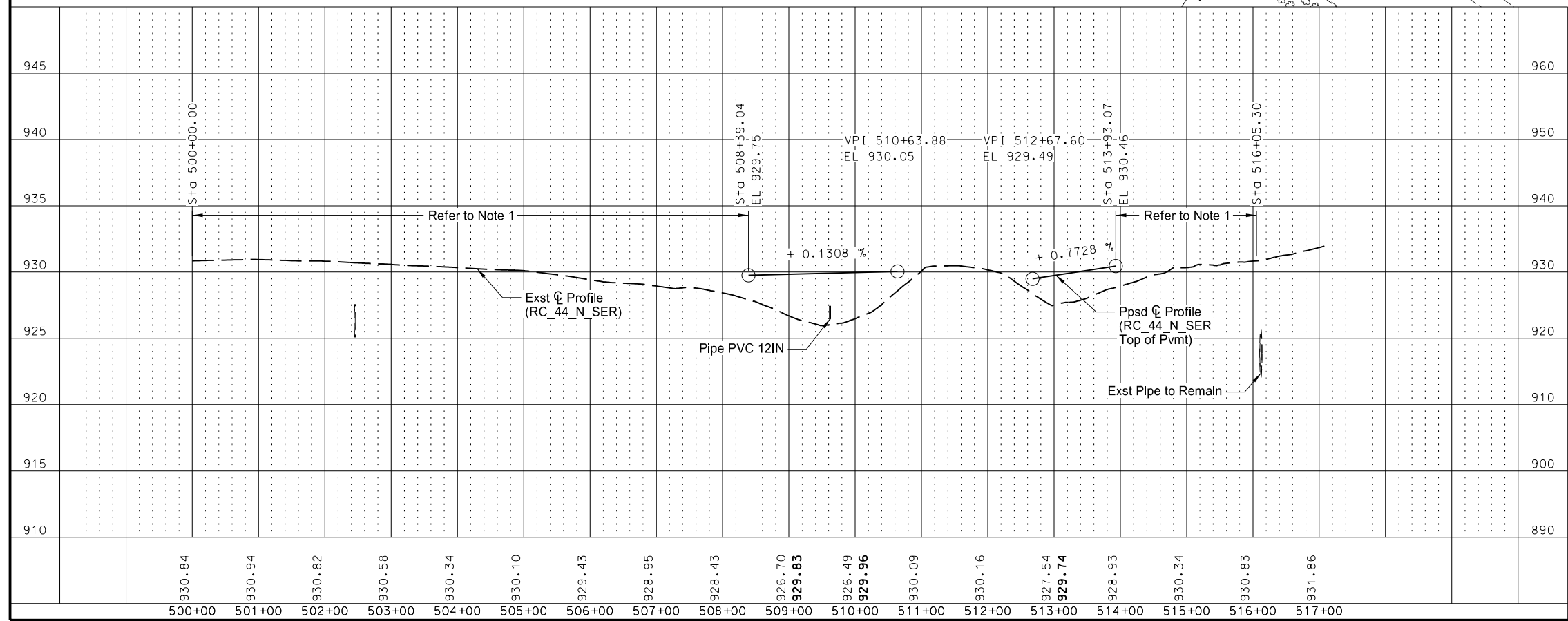

I-29 - N of Galchutt Exit to Christine Exit
 Plan & Profile
 Christine Interchange Southeast Ramp Connection
 Sta 500+00 to 516+05 (RC_44_N_SER)

Wetland Impact Table																				
Wetland Number	Location	Wetland Feature	USACE Jurisdictional Wetlands	Wetland Impact Acre(s)		USFWS Easement Impacts Acre(s)		Wetland Mitigation												
				Temp.	Perm.	Temp.	Perm.	Mitigation Required			USACE/11990 Bank		11990 Bank		USFWS Bank		Onsite			
								EO 11990	USACE	USFWS	Location	Acre(s)	Location	Acre(s)	Location	Acre(s)	Mitigation Location; Ratio	Acre(s)	Constructed Site #	Constructed Size Acre(s)
1a	Sec 15, T134N, R49W	Artificial	Y	0.19	-			N	N	N										
1b	Sec 15, T134N, R49W	Artificial	Y	0.07	-			N	N	N										
1c	Sec 15, T134N, R49W	Artificial	Y	-	-			N	N	N										
1d	Sec 15, T134N, R49W	Artificial	Y	0.92	-			N	N	N										
1e	Sec 10, T134N, R49W	Artificial	Y	0.01	-			N	N	N										
1f	Sec 10, T134N, R49W	Artificial	Y	0.41	-			N	N	N										
1g	Sec 10, T134N, R49W	Natural	Y	-	-			N	N	N										
1h	Sec 10, T134N, R49W	Artificial	Y	-	-			N	N	N										
1i	Sec 10, T134N, R49W	Natural	Y	-	-			N	N	N										
1j	Sec 10, T134N, R49W	Natural	Y	-	-			N	N	N										
1k	Sec 10, T134N, R49W	Artificial	Y	0.25	0.05			N	N	N										
1l	Sec 10, T134N, R49W	Natural	Y	-	-			N	N	N										
1m	Sec 10, T134N, R49W	Artificial	Y	-	-			N	N	N										
1n	Sec 10, T134N, R49W	Natural	Y	-	-			N	N	N										
1p	Sec 15, T134N, R49W	Natural	Y	0.07	-			N	N	N										
2a	Sec 10, T134N, R49W	Artificial	N	0.06	0.01			N	N	N										
2b	Sec 10, T134N, R49W	Artificial	N	1.05	-			N	N	N										
2c	Sec 10, T134N, R49W	Artificial	N	-	-			N	N	N										
3	Sec 10, T134N, R49W	Artificial	N	-	-			N	N	N										
4	Sec 3, T134N, R49W	Artificial	N	-	-			N	N	N										
5a	Sec 3, T134N, R49W Sec 34, T135N, R49W	Artificial	Y	0.16	0.01			N	N	N										
5b	Sec 3, T134N, R49W	Artificial	Y	0.60	-			N	N	N										

This document was originally issued and sealed by Matt Lange, Registration Number PE- 6870, on 08/07/17 and the original document is stored at the North Dakota Department of Transportation

I-29 N of Galchutt Exit to Christine Exit
Wetlands, Mitigation and Environmental
Wetland Impact Table

Wetland Impact Table																				
Wetland Number	Location	Wetland Feature	USACE Jurisdictional Wetlands	Wetland Impact Acre(s)		USFWS Easement Impacts Acre(s)		Wetland Mitigation												
				Temp.	Perm.	Temp.	Perm.	Mitigation Required			USACE/11990 Bank		11990 Bank		USFWS Bank		Onsite			
								EO 11990	USACE	USFWS	Location	Acre(s)	Location	Acre(s)	Location	Acre(s)	Mitigation Location; Ratio	Acre(s)	Constructed Site #	Constructed Size Acre(s)
5c	Sec 34, T135N, R49W	Artificial	Y	-	-			N	N	N										
5d	Sec 3, T134N, R49W	Artificial	Y	0.15	-			N	N	N										
5e	Sec 34, T135N, R49W	Artificial	Y	0.60	-			N	N	N										
5f	Sec 34, T135N, R49W	Artificial	Y	0.30	0.01			N	N	N										
5g	Sec 34, T135N, R49W	Artificial	Y	-	-			N	N	N										
5h	Sec 27, T135N, R49W	Artificial	Y	0.06	-			N	N	N										
5i	Sec 27, T135N, R49W	Artificial	Y	0.31	-			N	N	N										
5j	Sec 27, T135N, R49W	Artificial	Y	0.02	-			N	N	N										
5k	Sec 27, T135N, R49W	Artificial	Y	-	-			N	N	N										
5l	Sec 27, T135N, R49W	Artificial	Y	0.03	0.01			N	N	N										
5m	Sec 27, T135N, R49W	Artificial	Y	-	-			N	N	N										
5p	Sec 3, T135N, R49W	Natural	Y	-	-			N	N	N										
5q	Sec 3, T135N, R49W	Natural	Y	-	-			N	N	N										
6	Sec 34, T135N, R49W	Artificial	N	-	-			N	N	N										
7	Sec 3, T135N, R49W	Natural	Y	-	-			N	N	N										
8	Sec 34, T135N, R49W	Artificial	N	0.18	-			N	N	N										
9	Sec 22, T135N, R49W	Artificial	N	-	-			N	N	N										
10	Sec 22, T135N, R49W	Artificial	N	-	-			N	N	N										
11	Sec 22, T135N, R49W	Artificial	N	-	-			N	N	N										
12a	Sec 22, T135N, R49W	Artificial	Y	-	-			N	N	N										
12b	Sec 22, T135N, R49W	Artificial	Y	0.01	-			N	N	N										
12c	Sec 22, T135N, R49W	Artificial	Y	0.01	0.01			N	N	N										

This document was originally issued and sealed by Matt Lange, Registration Number PE- 6870, on 08/07/17 and the original document is stored at the North Dakota Department of Transportation

I-29 N of Galchutt Exit to Christine Exit
Wetlands, Mitigation and Environmental
Wetland Impact Table

Wetland Impact Table																				
Wetland Number	Location	Wetland Feature	USACE Jurisdictional Wetlands	Wetland Impact Acre(s)		USFWS Easement Impacts Acre(s)		Wetland Mitigation												
				Temp.	Perm.	Temp.	Perm.	Mitigation Required			USACE/11990 Bank		11990 Bank		USFWS Bank		Onsite			
								EO 11990	USACE	USFWS	Location	Acre(s)	Location	Acre(s)	Location	Acre(s)	Mitigation Location; Ratio	Acre(s)	Constructed Site #	Constructed Size Acre(s)
12d	Sec 15, T135N, R49W Sec 10, T135N, R49W Sec 10, T135N, R49W	Artificial	Y	-	-			N	N	N										
12e	Sec 15, T135N, R49W	Artificial	Y	0.10	-			N	N	N										
12f	Sec 10, T135N, R49W	Artificial	Y	0.02	-			N	N	N										
13	Sec 15, T135N, R49W	Artificial	Y	-	-			N	N	N										
14	Sec 15, T135N, R49W	Artificial	N	0.05	-			N	N	N										
15	Sec 10, T135N, R49W	Artificial	Y	0.08	-			N	N	N										
16	Sec 10, T135N, R49W	Natural	Y	-	-			N	N	N										
17	Sec 10, T135N, R49W	Artificial	N	-	-			N	N	N										
18	Sec 10, T135N, R49W	Artificial	N	-	-			N	N	N										
19a	Sec 10, T135N, R49W	Artificial	Y	-	-			N	N	N										
19b	Sec 10, T135N, R49W	Artificial	Y	-	-			N	N	N										
19c	Sec 10, T135N, R49W	Artificial	Y	0.01	-			N	N	N										
19d	Sec 10, T135N, R49W	Artificial	Y	0.01	0.01			N	N	N										
19e	Sec 10, T135N, R49W	Artificial	Y	0.01	-			N	N	N										
20	Sec 10, T135N, R49W	Artificial	Y	0.03	-			N	N	N										
21	Sec 10, T135N, R49W	Artificial	N	-	-			N	N	N										
22	Sec 10, T135N, R49W	Artificial	N	-	-			N	N	N										
23a	Sec 10, T135N, R49W	Artificial	Y	-	-			N	N	N										
23b	Sec 10, T135N, R49W	Natural	Y	0.03	-			N	N	N										
24	Sec 3, T135N, R49W	Artificial	Y	0.01	-			N	N	N										
25	Sec 3, T135N, R49W	Artificial	N	-	-			N	N	N										

This document was originally issued and sealed by Matt Lange, Registration Number PE- 6870, on 08/07/17 and the original document is stored at the North Dakota Department of Transportation

I-29 N of Galchutt Exit to Christine Exit
Wetlands, Mitigation and Environmental
Wetland Impact Table

Wetland Impact Table																				
Wetland Number	Location	Wetland Feature	USACE Jurisdictional Wetlands	Wetland Impact Acre(s)		USFWS Easement Impacts Acre(s)		Wetland Mitigation												
				Temp.	Perm.	Temp.	Perm.	Mitigation Required			USACE/11990 Bank		11990 Bank		USFWS Bank		Onsite			
								EO 11990	USACE	USFWS	Location	Acre(s)	Location	Acre(s)	Location	Acre(s)	Mitigation Location; Ratio	Acre(s)	Constructed Site #	Constructed Size Acre(s)
26	Sec 3, T135N, R49W	Artificial	Y	0.01	-			N	N	N										
27	Sec 3, T135N, R49W	Natural	Y	-	-			N	N	N										
29a	Sec 3, T135N, R49W	Artificial	Y	0.02	0.02			N	N	N										
29b	Sec 3, T135N, R49W	Artificial	Y	-	-			N	N	N										
29c	Sec 3, T135N, R49W	Natural	Y	0.01	-			N	N	N										
30	Sec 3, T135N, R49W	Artificial	N	-	-			N	N	N										
31a	Sec 3, T135N, R49W	Artificial	Y	0.11	0.01			N	N	N										
31b	Sec 34, T136N, R49W	Artificial	Y	0.04	-			N	N	N										
31c	Sec 34, T136N, R49W	Artificial	Y	0.07	-			N	N	N										
31d	Sec 34, T136N, R49W Sec 27, T136N, R49W	Artificial	Y	-	-			N	N	N										
31e	Sec 27, T136N, R49W	Artificial	Y	0.01	0.01			N	N	N										
32	Sec 34, T136N, R49W	Artificial	N	-	0.28			N	N	N										
33	Sec 34, T136N, R49W	Artificial	N	0.12	-			N	N	N										
34	Sec 34, T136N, R49W	Artificial	Y	-	-			N	N	N										
35	Sec 34, T136N, R49W	Artificial	N	0.05	-			N	N	N										
36	Sec 27, T136N, R49W	Artificial	N	0.04	-			N	N	N										
37	Sec 27, T136N, R49W	Artificial	N	-	-			N	N	N										
38	Sec 27, T136N, R49W	Artificial	N	-	-			N	N	N										
39	Sec 27, T136N, R49W	Artificial	N	-	-			N	N	N										
40a	Sec 27, T136N, R49W	Artificial	Y	0.01	-			N	N	N										
40b	Sec 27, T136N, R49W	Artificial	Y	0.32	-			N	N	N										
40c	Sec 26, T136N, R49W	Artificial	Y	0.03	-			N	N	N										

This document was originally issued and sealed by Matt Lange, Registration Number PE- 6870, on 08/07/17 and the original document is stored at the North Dakota Department of Transportation

I-29 N of Galchutt Exit to Christine Exit
Wetlands, Mitigation and Environmental
Wetland Impact Table

Wetland Impact Table																				
Wetland Number	Location	Wetland Feature	USACE Jurisdictional Wetlands	Wetland Impact Acre(s)		USFWS Easement Impacts Acre(s)		Wetland Mitigation												
				Temp.	Perm.	Temp.	Perm.	Mitigation Required			USACE/11990 Bank		11990 Bank		USFWS Bank		Onsite			
								EO 11990	USACE	USFWS	Location	Acre(s)	Location	Acre(s)	Location	Acre(s)	Mitigation Location; Ratio	Acre(s)	Constructed Site #	Constructed Size Acre(s)
40d	Sec 27, T136N, R49W	Artificial	Y	-	-			N	N	N										
41	Sec 26, T136N, R49W	Artificial	N	-	-			N	N	N										
42	Sec 22, T136N, R49W	Artificial	N	-	-			N	N	N										
43	Sec 22, T136N, R49W	Artificial	N	-	-			N	N	N										
44	Sec 22, T136N, R49W	Artificial	N	-	-			N	N	N										
45	Sec 23, T136N, R49W	Artificial	Y	-	-			N	N	N										
46	Sec 22, T136N, R49W	Artificial	Y	-	-			N	N	N										
				6.65	0.43	NA	NA				NA		NA		NA		NA		NA	

¹ A wetland Jurisdictional Determination was issued by the USACE on 1/26/2017; NWO-2012-0172-BIS.

² 1199 Mitigation requirements - All impacts to natural wetlands (natural/jurisdictional and natural/non-jurisdictional), regardless of size, as well as impacts greater than 0.10 acre to wetlands require mitigation.

USACE Mitigation Requirements - All jurisdictional impacts greater than 0.10 acre to each resource (cumulative. eg 1a ,1b,1c..etc.) requires mitigation. Other Water impact greater than 300 linear feet requires mitigation.

³ All artificial/non-jurisdictional, deep water (impacts greater than 6.6 feet), Other Waters less than 300 linear feet (determined by the USACE on a case by case), and temporary impacts do not require mitigation.

Other Waters Impact Table															
Number	Location	Type	Other Waters				Other Water Mitigation								
			Size		Feature	USACE Jurisdictional	Impacts to Other Waters			Mitigation Required			Mitigation Location; ratio	Method	
			Acre(s)	Linear Feet			Acre(s) Temp	Perm	Linear Feet Temp	Perm	EO 11990	USACE			USFWS
OW 1o	Sec 10, T134N, R49W	Creek	0.09	405	Natural	Y	-	-	-	-	N	N	N		
OW 5n	Sec 27, T135N, R49W	Tributary	0.07	100	Artificial	Y	-	-	-	-	N	N	N		
OW 5o	Sec 27, T135N, R49W	Tributary	0.06	111	Artificial	Y	0.01	0.01	18	28	N	N	N		
OW 12g	Sec 15, T135N, R49W	Tributary	0.05	95	Artificial	Y	0.05	-	95	-	N	N	N		
OW 28	Sec 3, T135N, R49W	River	0.71	399	Natural	Y	-	-	-	-	N	N	N		
Totals			0.98	1110			0.06	0.01	113	28					





Impact Summary Table			
Permanent Impact Summary		Temporary Impacts and additional information	
Wetland Type	Total (Acres)	Wetland Type	Total (Acres/Lf)
Natural/JD	0.00	Temporary JD	5.10
Natural/Non-JD	0.00	Non-JD Temporary	1.55
Artificial/JD	0.14	Permanent JD > 0.10	0.00
Artificial/Non-JD	0.29	Permanent OW	0.01 / 28
Total	0.43	Temporary OW	0.06 / 113

This document was originally issued and sealed by Matt Lange, Registration Number PE- 6870, on 08/07/17 and the original document is stored at the North Dakota Department of Transportation

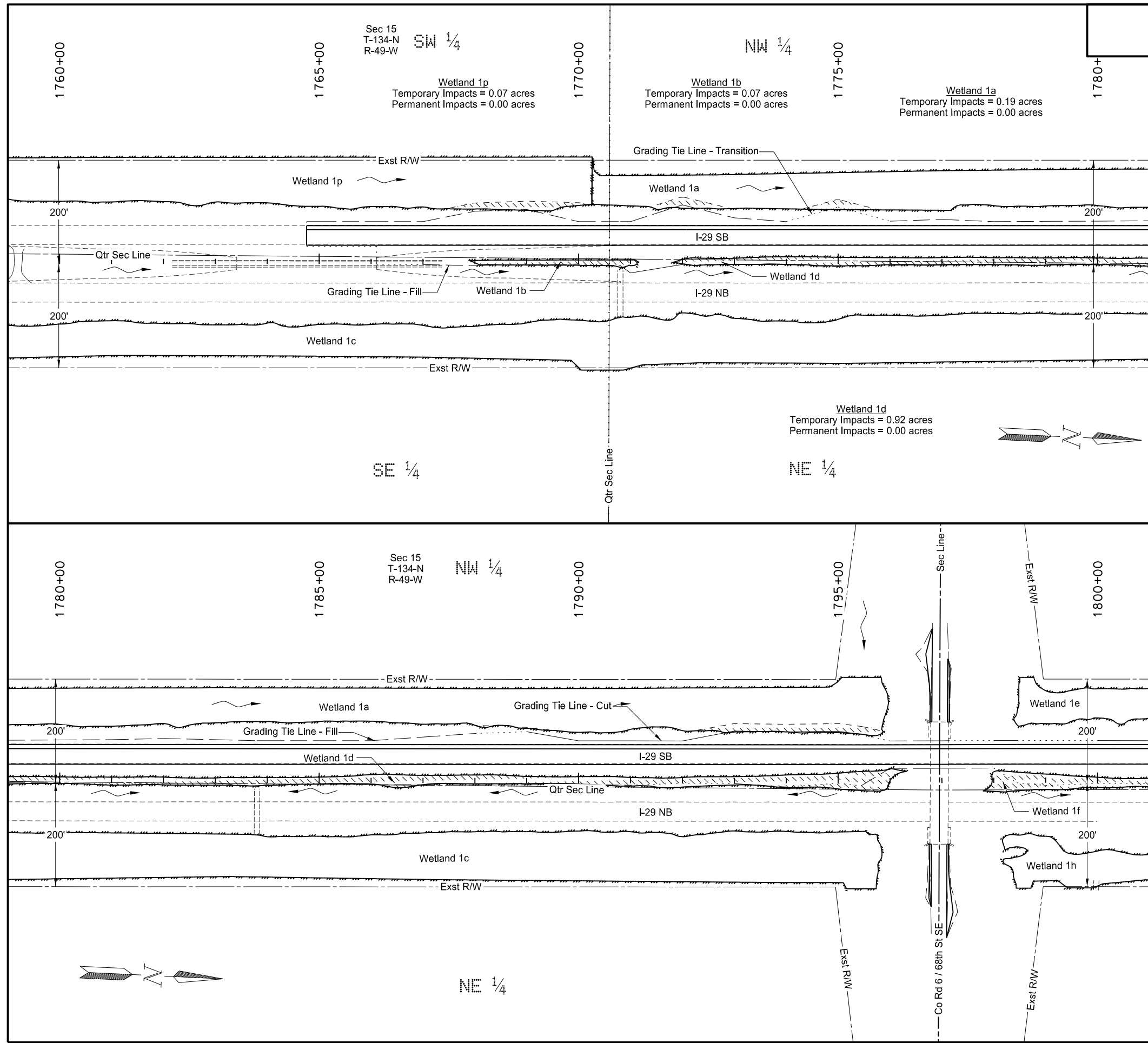
I-29 N of Galchutt Exit to Christine Exit
Wetlands, Mitigation and Environmental
Wetland Impact Table

STATE	PROJECT NO.	SECTION NO.	SHEET NO.
ND	IM-8-029(170)033	75	6



-  Wetland Impact Permanent
-  Wetland Impact Temporary
-  Existing Delineated Wetland
-  Existing Other Waters

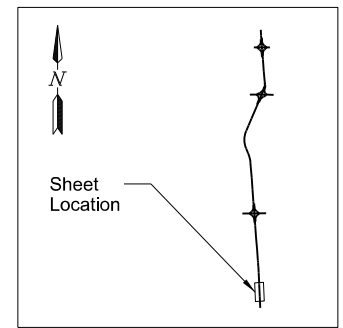



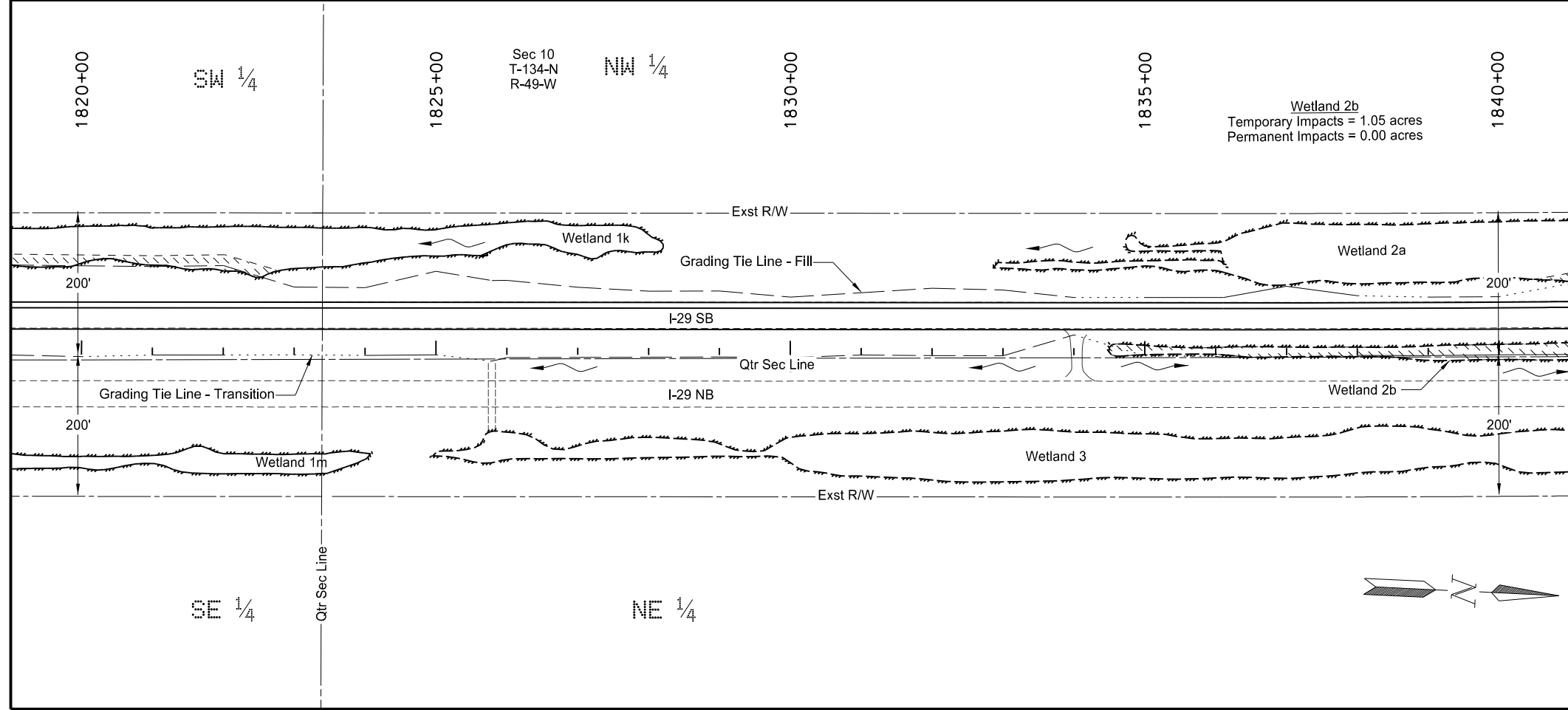
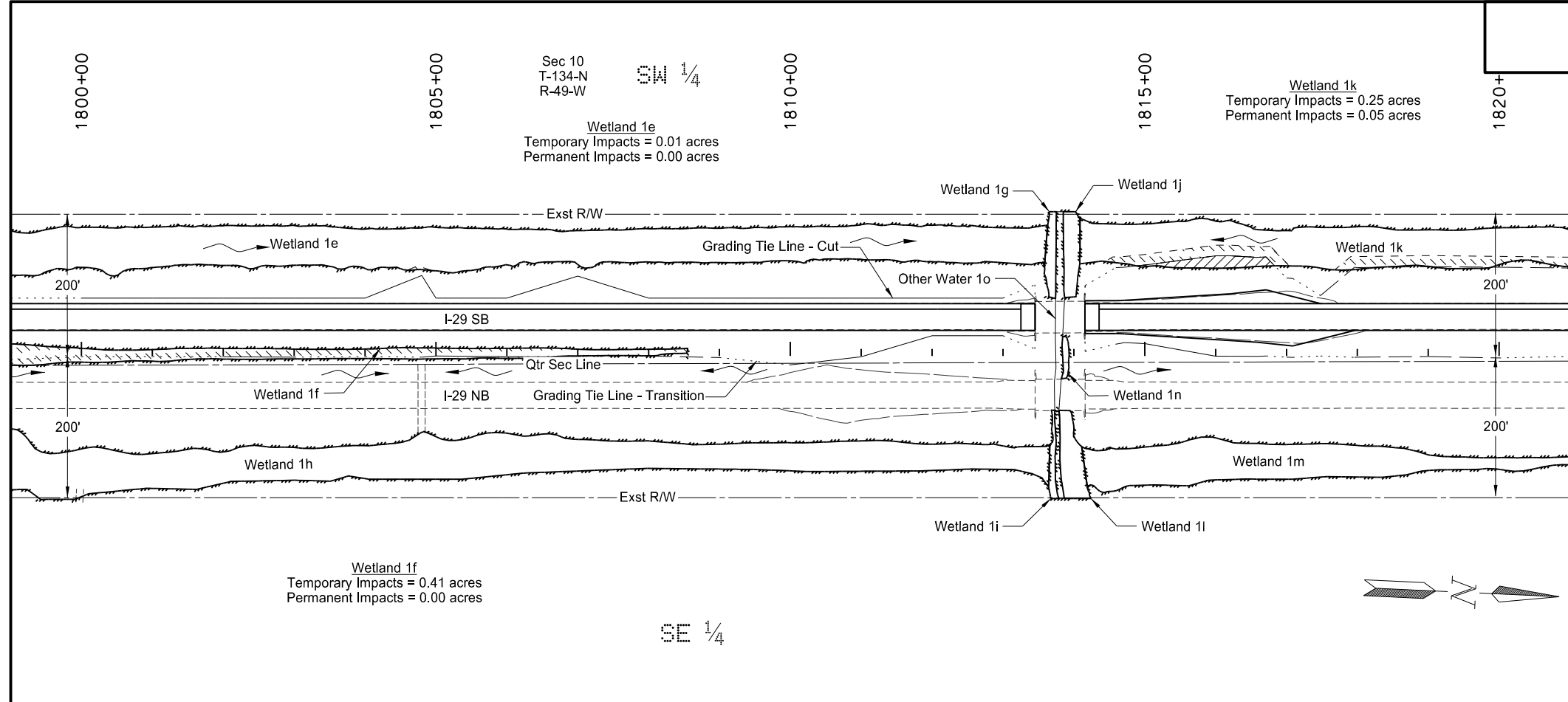

This document was originally issued and sealed by Matt Lange, Registration Number PE- 6870, on 08/07/17 and the original document is stored at the North Dakota Department of Transportation

I-29 - N of Galchutt Exit to Christine Exit
 Wetlands, Mitigation and Environmental
 Interstate 29
 Sta 1760+00 to 1800+00 (SCL29)

STATE	PROJECT NO.	SECTION NO.	SHEET NO.
ND	IM-8-029(170)033	75	7



-  Wetland Impact Permanent
-  Wetland Impact Temporary
-  Existing Delineated Wetland
-  Existing Other Waters

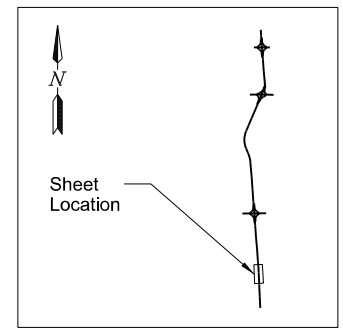



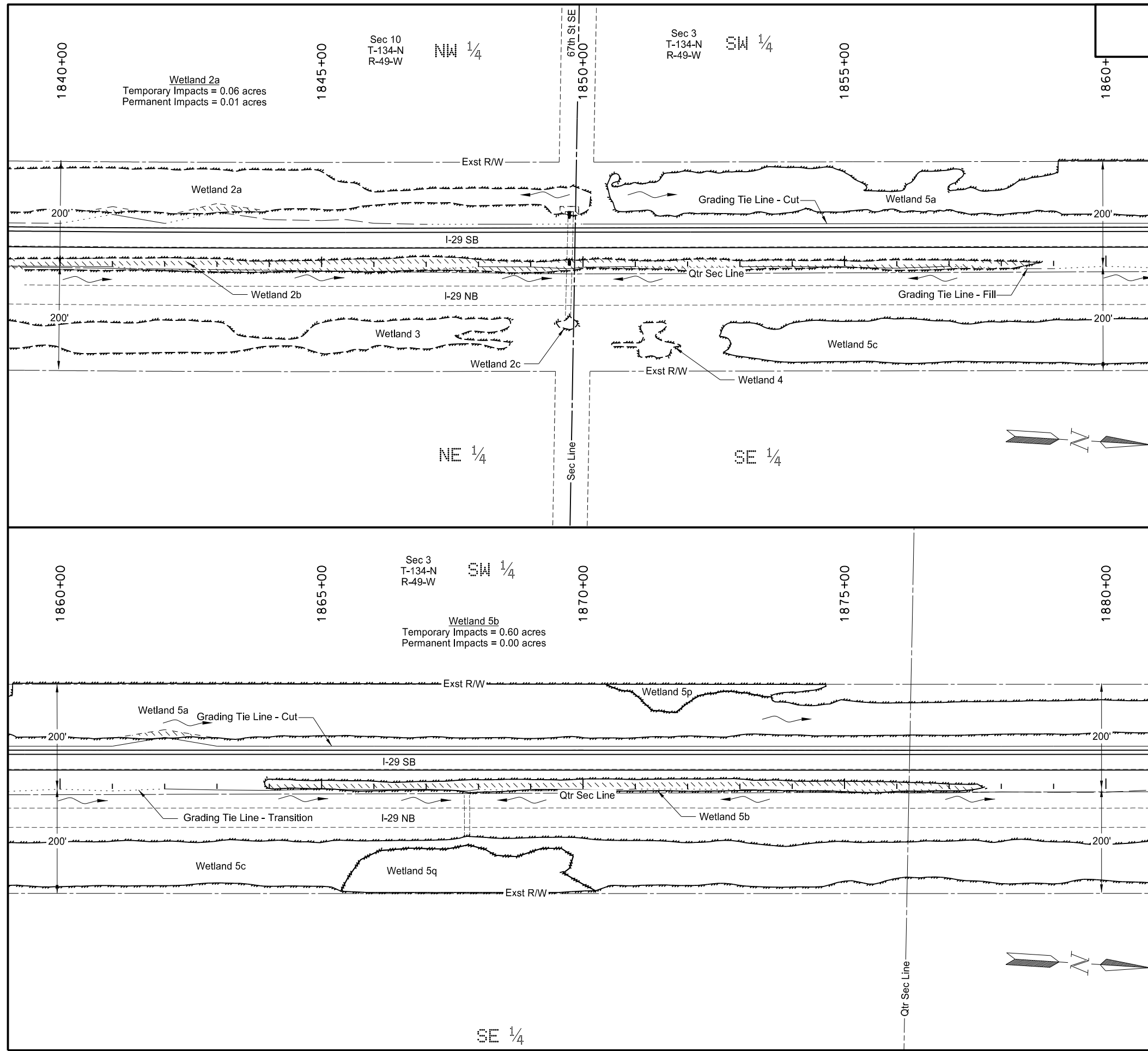

This document was originally issued and sealed by
 Matt Lange,
 Registration Number
 PE- 6870,
 on 08/07/17 and the original document is stored at the
 North Dakota Department
 of Transportation

I-29 - N of Galchutt Exit to Christine Exit
 Wetlands, Mitigation and Environmental
 Interstate 29
 Sta 1800+00 to 1840+00 (SCL29)

STATE	PROJECT NO.	SECTION NO.	SHEET NO.
ND	IM-8-029(170)033	75	8



-  Wetland Impact Permanent
-  Wetland Impact Temporary
-  Existing Delineated Wetland
-  Existing Other Waters

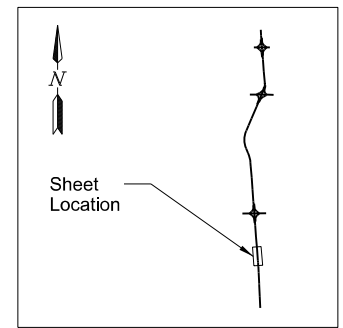



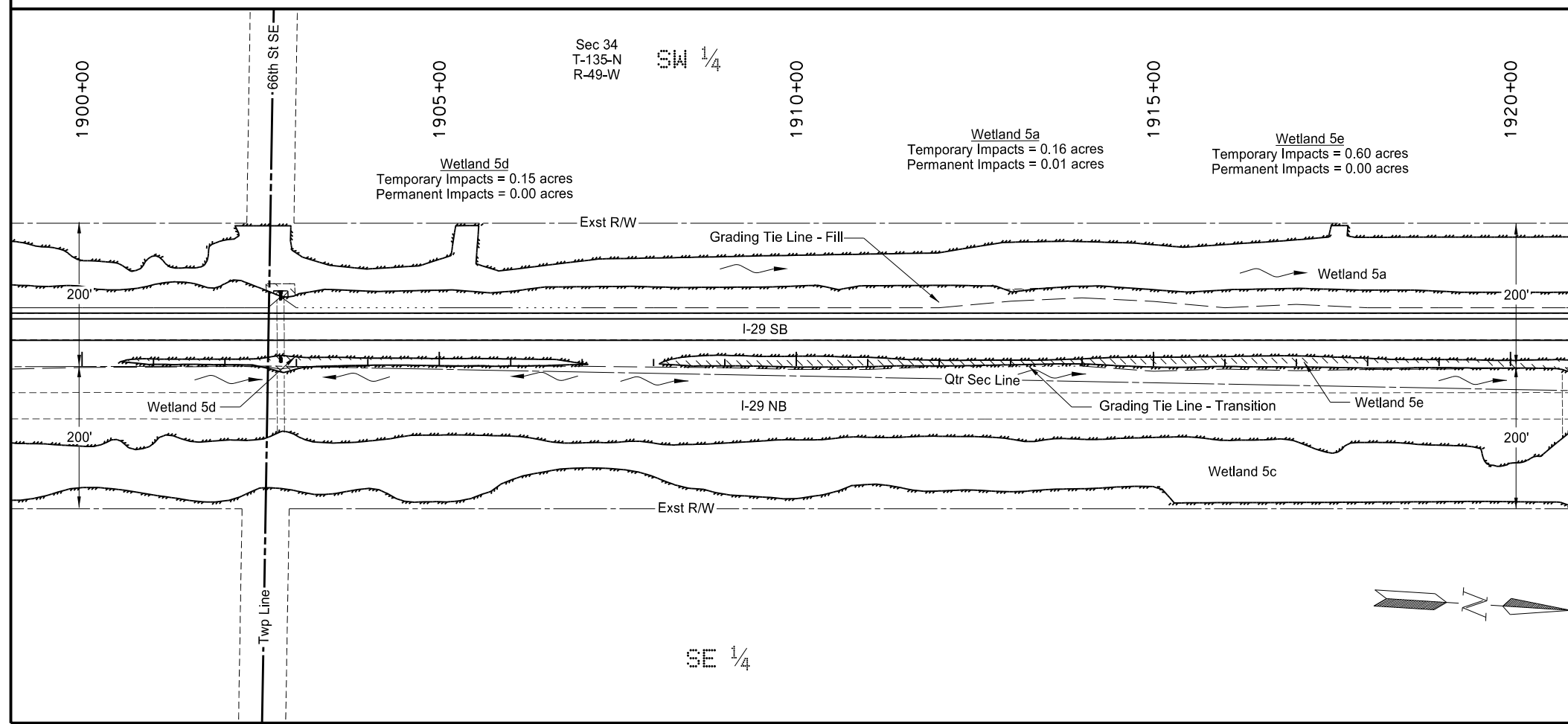
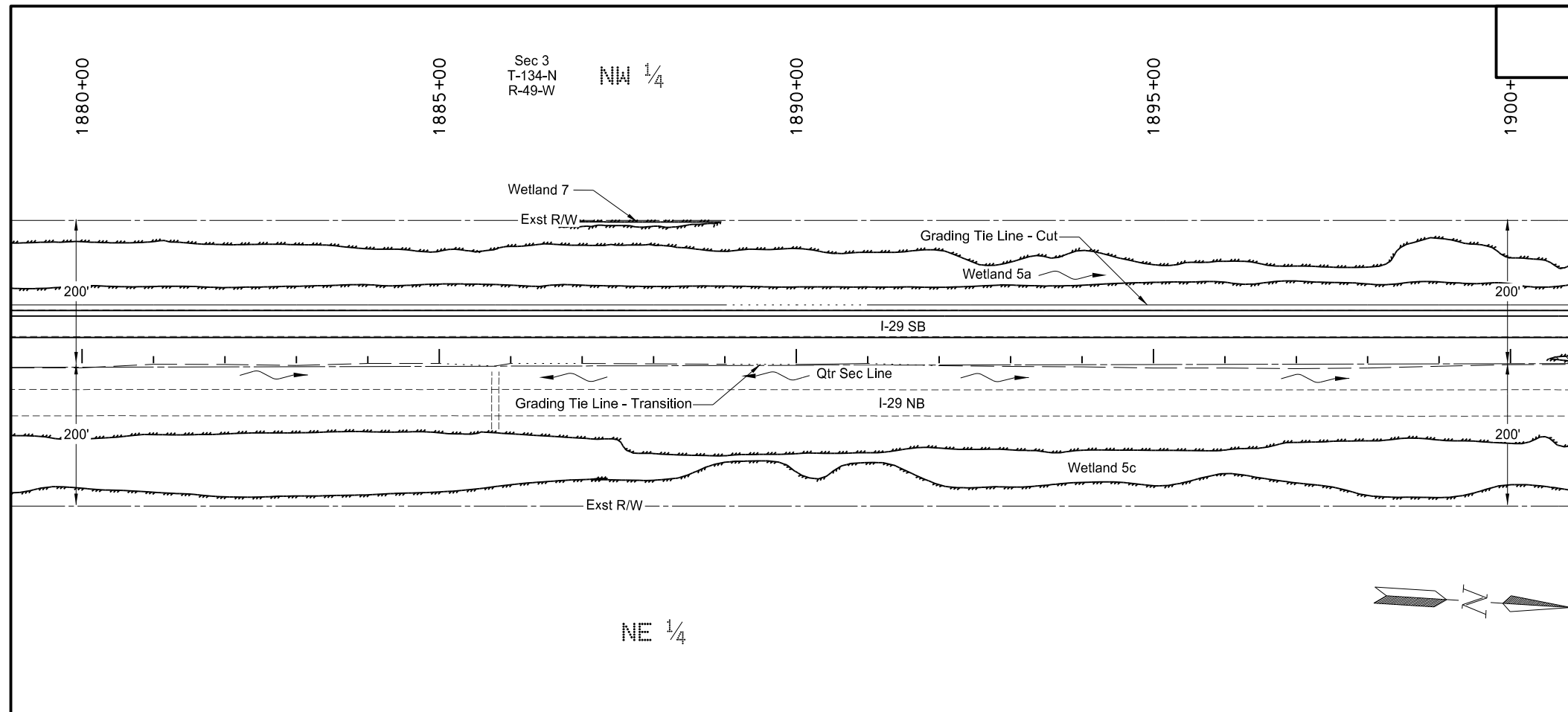

This document was originally issued and sealed by
 Matt Lange,
 Registration Number
 PE- 6870,
 on 08/07/17 and the original document is stored at the
 North Dakota Department
 of Transportation

I-29 - N of Galchutt Exit to Christine Exit
 Wetlands, Mitigation and Environmental
 Interstate 29
 Sta 1840+00 to 1880+00 (SCL29)

STATE	PROJECT NO.	SECTION NO.	SHEET NO.
ND	IM-8-029(170)033	75	9



-  Wetland Impact Permanent
-  Wetland Impact Temporary
-  Existing Delineated Wetland
-  Existing Other Waters

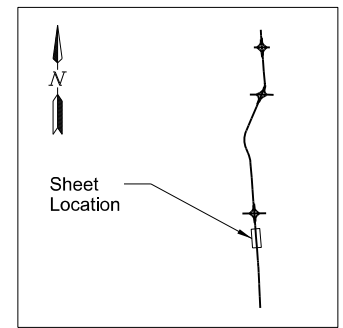



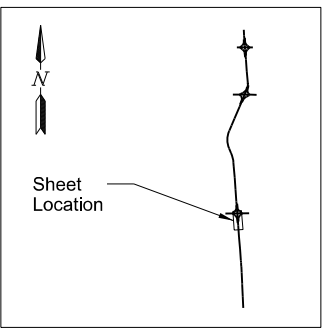
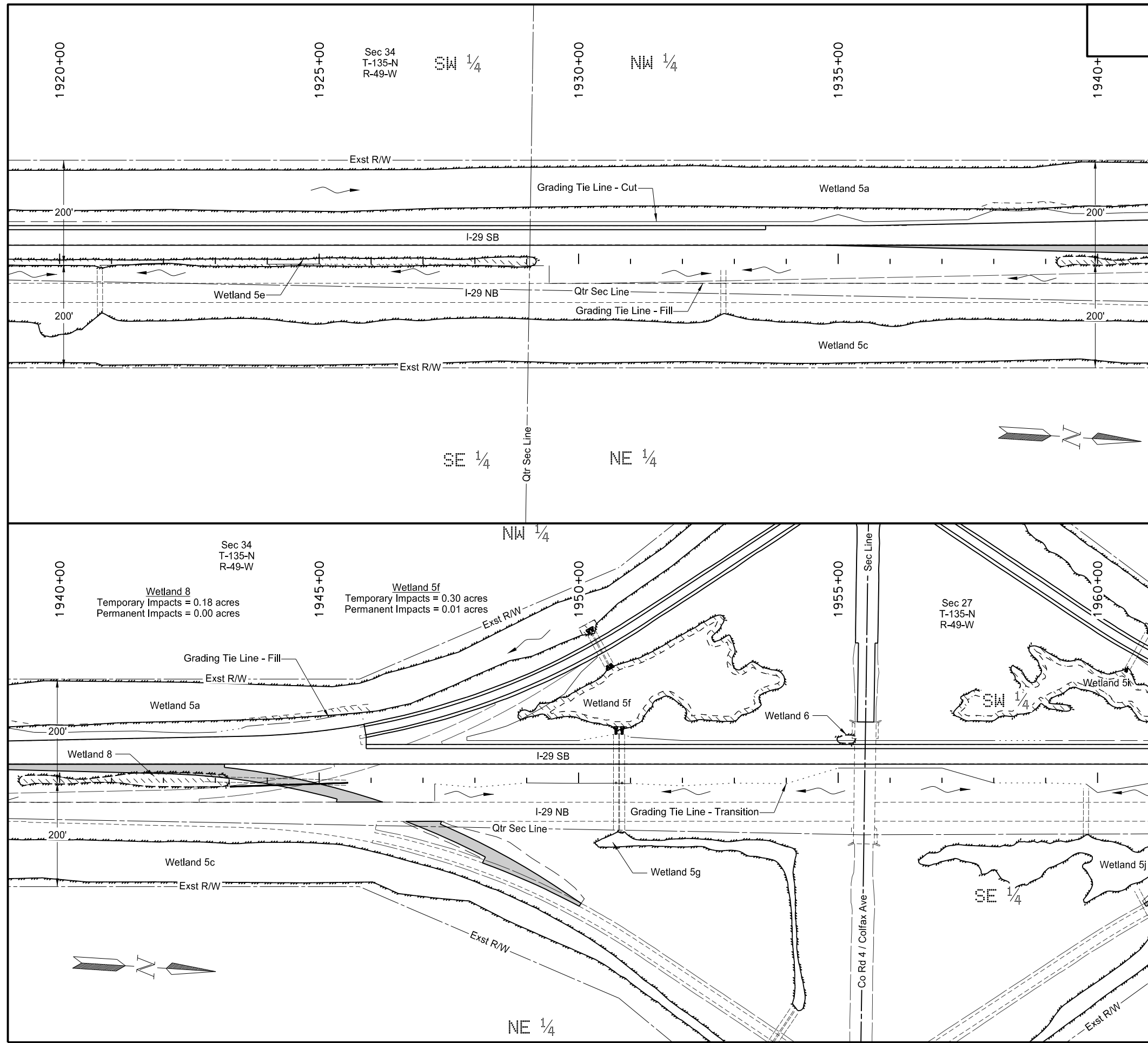

This document was originally issued and sealed by Matt Lange, Registration Number PE- 6870, on 08/07/17 and the original document is stored at the North Dakota Department of Transportation

I-29 - N of Galchutt Exit to Christine Exit
 Wetlands, Mitigation and Environmental
 Interstate 29
 Sta 1880+00 to 1920+00 (SCL29)

STATE	PROJECT NO.	SECTION NO.	SHEET NO.
ND	IM-8-029(170)033	75	10







-  Wetland Impact Permanent
-  Wetland Impact Temporary
-  Existing Delineated Wetland
-  Existing Other Waters

This document was originally issued and sealed by Matt Lange, Registration Number PE- 6870, on 08/07/17 and the original document is stored at the North Dakota Department of Transportation

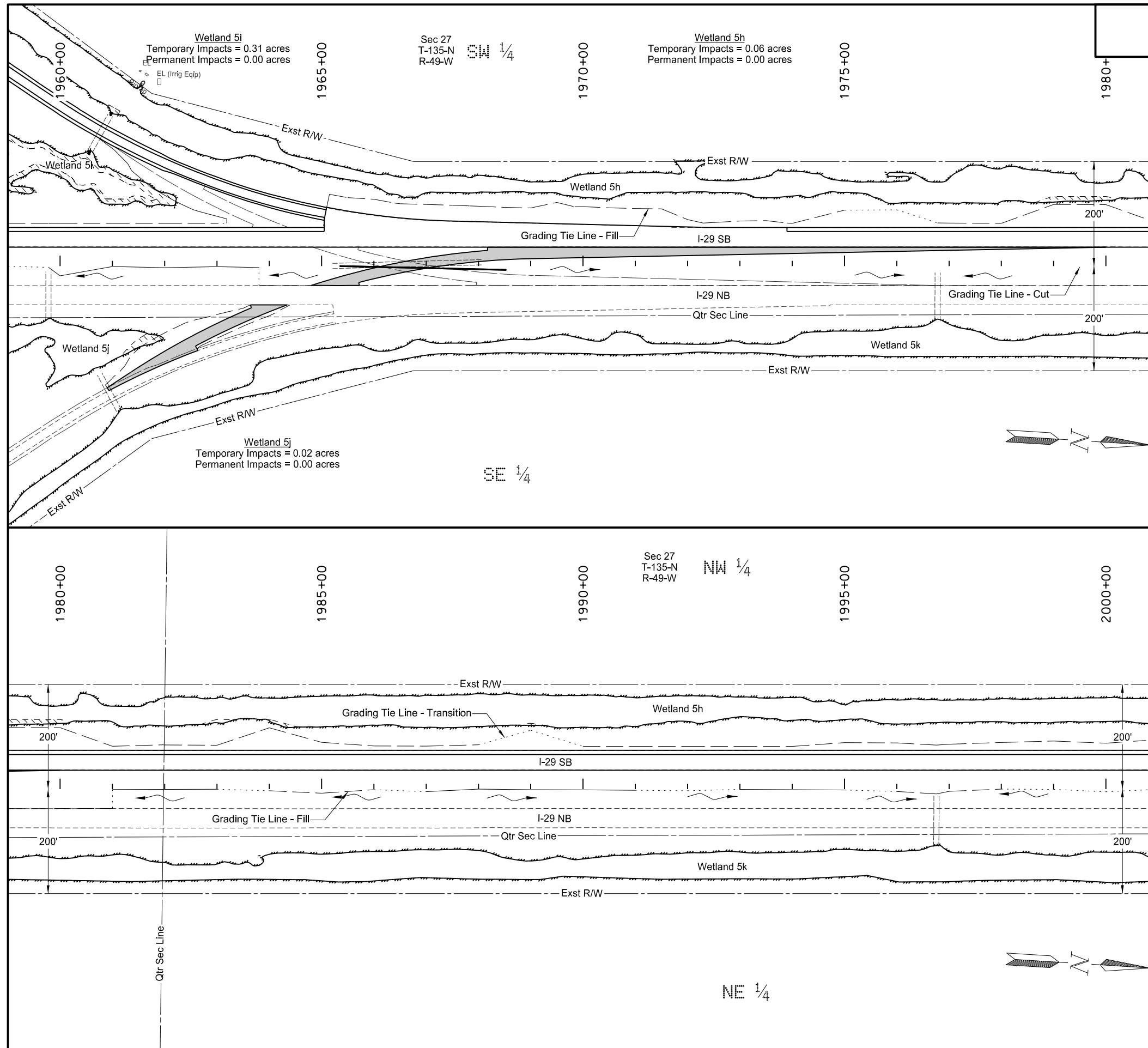
I-29 - N of Galchutt Exit to Christine Exit
 Wetlands, Mitigation and Environmental
 Interstate 29
 Sta 1920+00 to 1960+00 (SCL29)

STATE	PROJECT NO.	SECTION NO.	SHEET NO.
ND	IM-8-029(170)033	75	11



-  Wetland Impact Permanent
-  Wetland Impact Temporary
-  Existing Delineated Wetland
-  Existing Other Waters

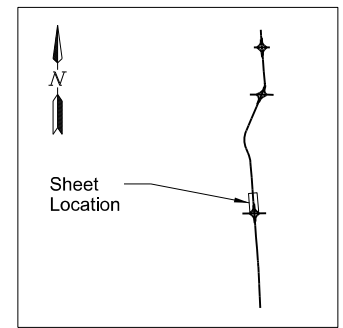

This document was originally issued and sealed by
 Matt Lange,
 Registration Number
 PE- 6870,
 on 08/07/17 and the original document is stored at the
 North Dakota Department
 of Transportation

I-29 - N of Galchutt Exit to Christine Exit
 Wetlands, Mitigation and Environmental
 Interstate 29
 Sta 1960+00 to 2000+00 (SCL29)

STATE	PROJECT NO.	SECTION NO.	SHEET NO.
ND	IM-8-029(170)033	75	12

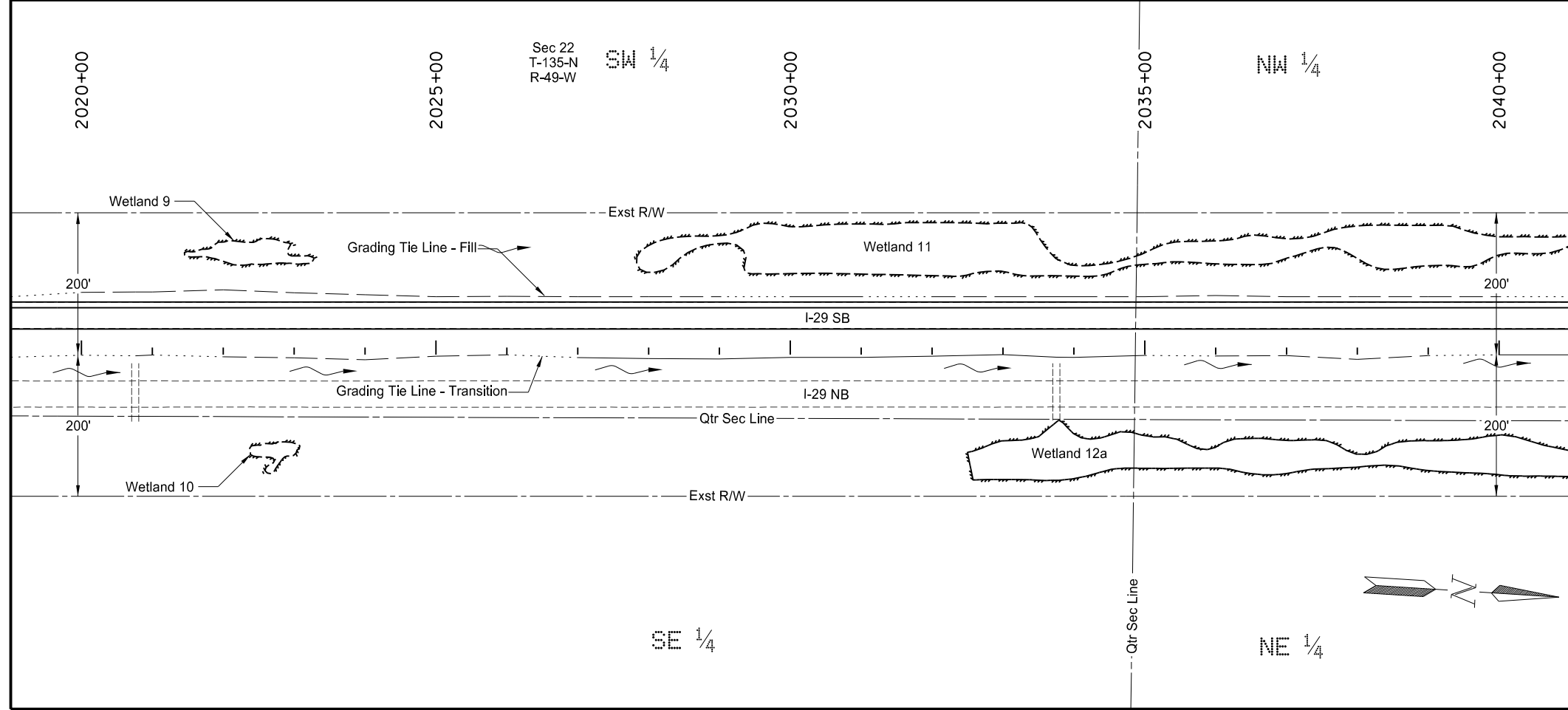
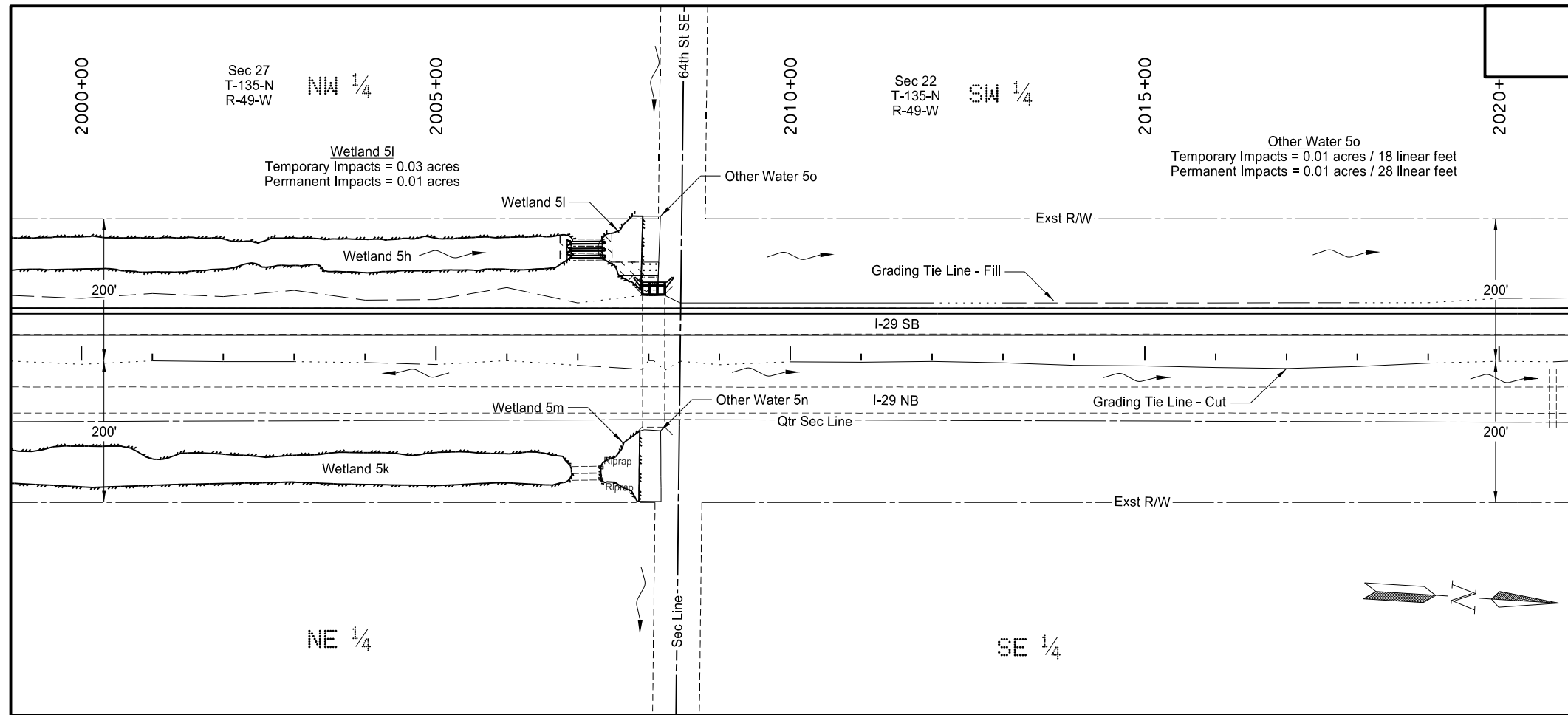

- Other Water Impact Permanent
- Other Water Impact Temporary
- Wetland Impact Permanent
- Wetland Impact Temporary
- Existing Delineated Wetland
- Existing Other Waters

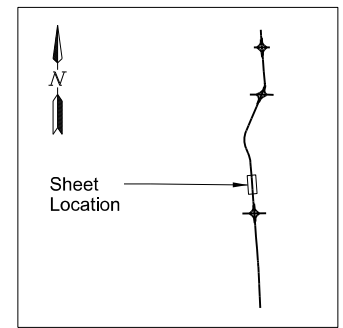

This document was originally issued and sealed by
 Matt Lange,
 Registration Number
 PE- 6870,
 on 08/07/17 and the original document is stored at the
 North Dakota Department
 of Transportation

I-29 - N of Galchutt Exit to Christine Exit
 Wetlands, Mitigation and Environmental
 Interstate 29
 Sta 2000+00 to 2040+00 (SCL29)

STATE	PROJECT NO.	SECTION NO.	SHEET NO.
ND	IM-8-029(170)033	75	13

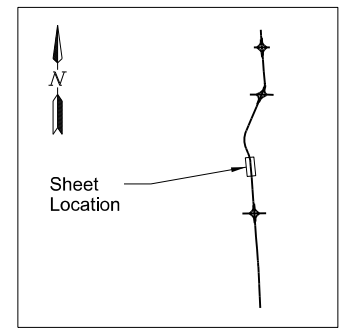
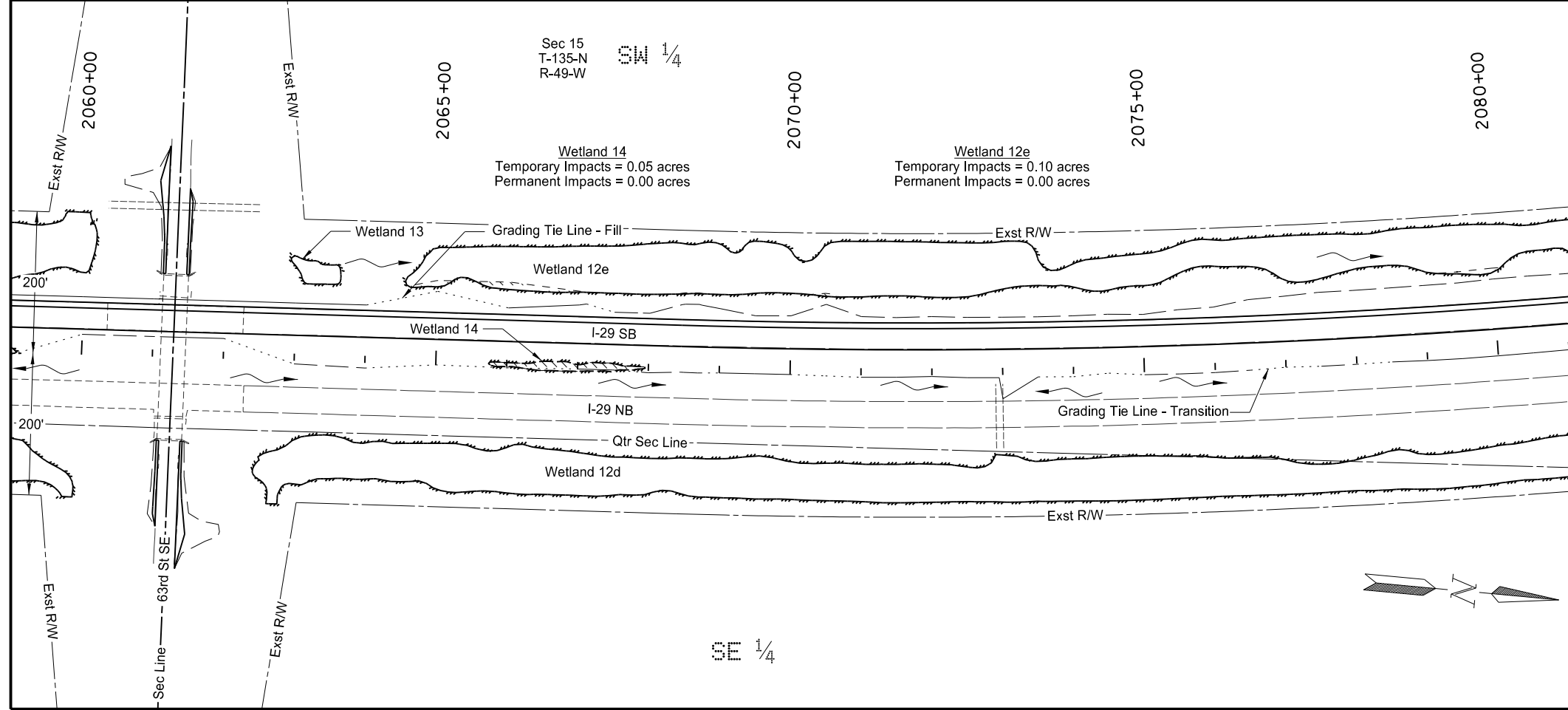
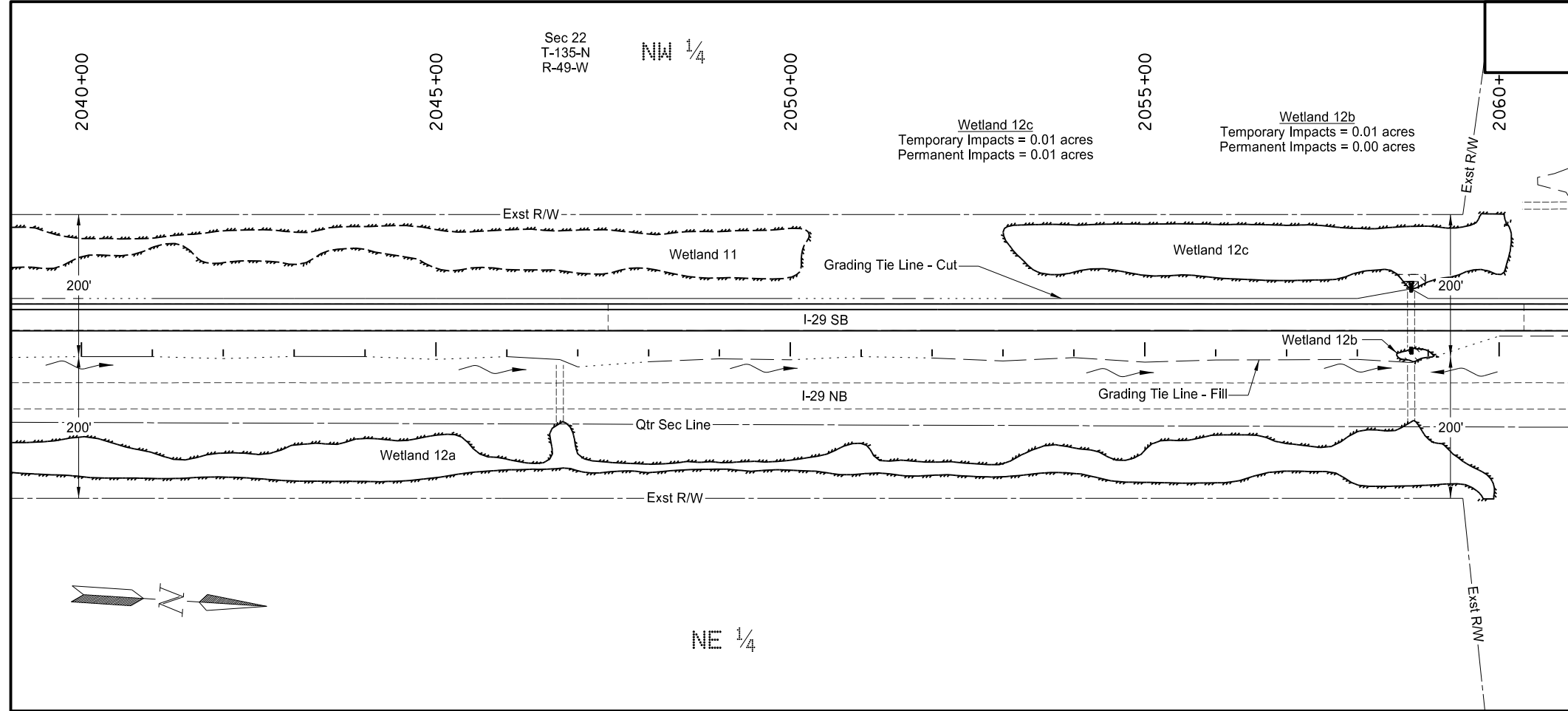

- Wetland Impact Permanent
- Wetland Impact Temporary
- Existing Delineated Wetland
- Existing Other Waters

This document was originally issued and sealed by
 Matt Lange,
 Registration Number
 PE- 6870,
 on 08/07/17 and the original document is stored at the
 North Dakota Department
 of Transportation

I-29 - N of Galchutt Exit to Christine Exit
 Wetlands, Mitigation and Environmental
 Interstate 29
 Sta 2040+00 to 2080+00 (SCL29)

STATE	PROJECT NO.	SECTION NO.	SHEET NO.
ND	IM-8-029(170)033	75	14

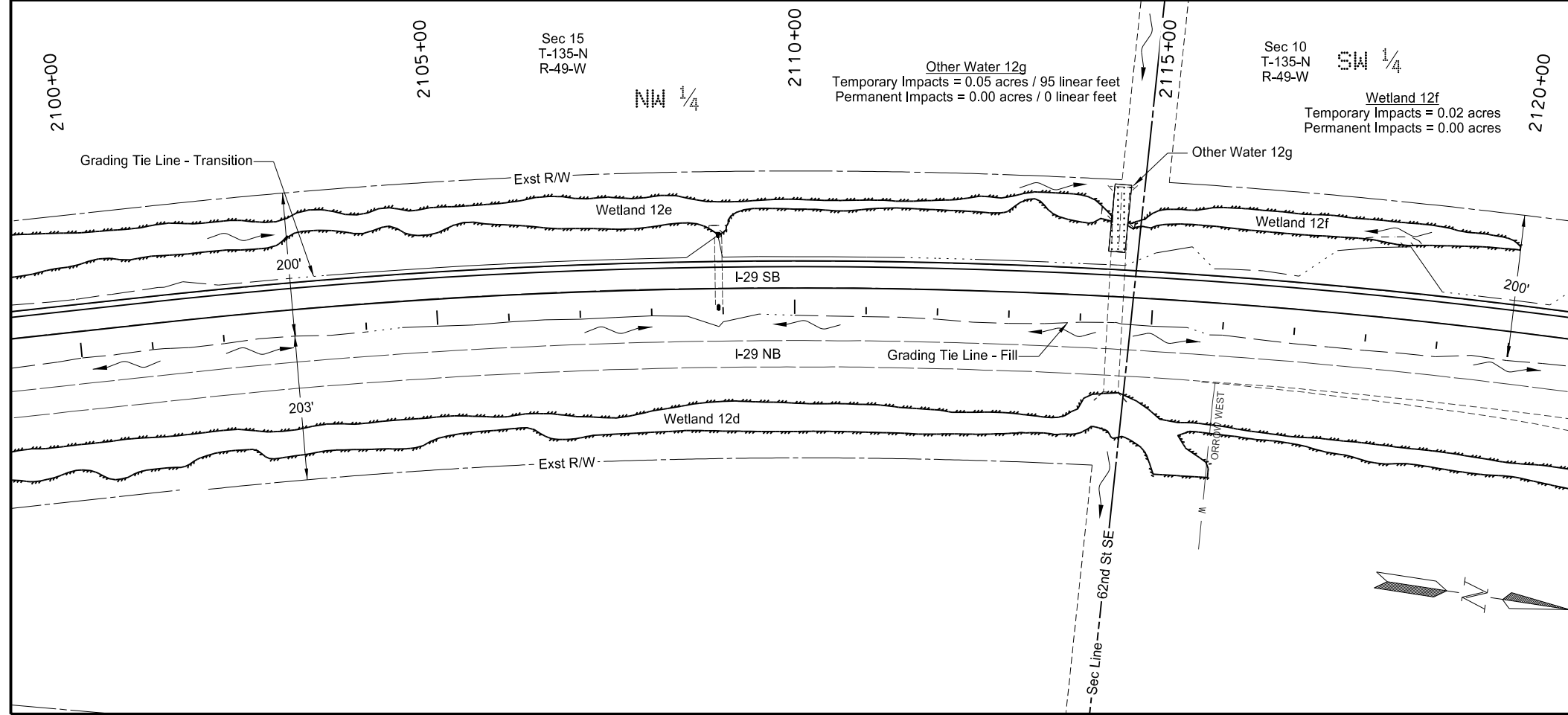
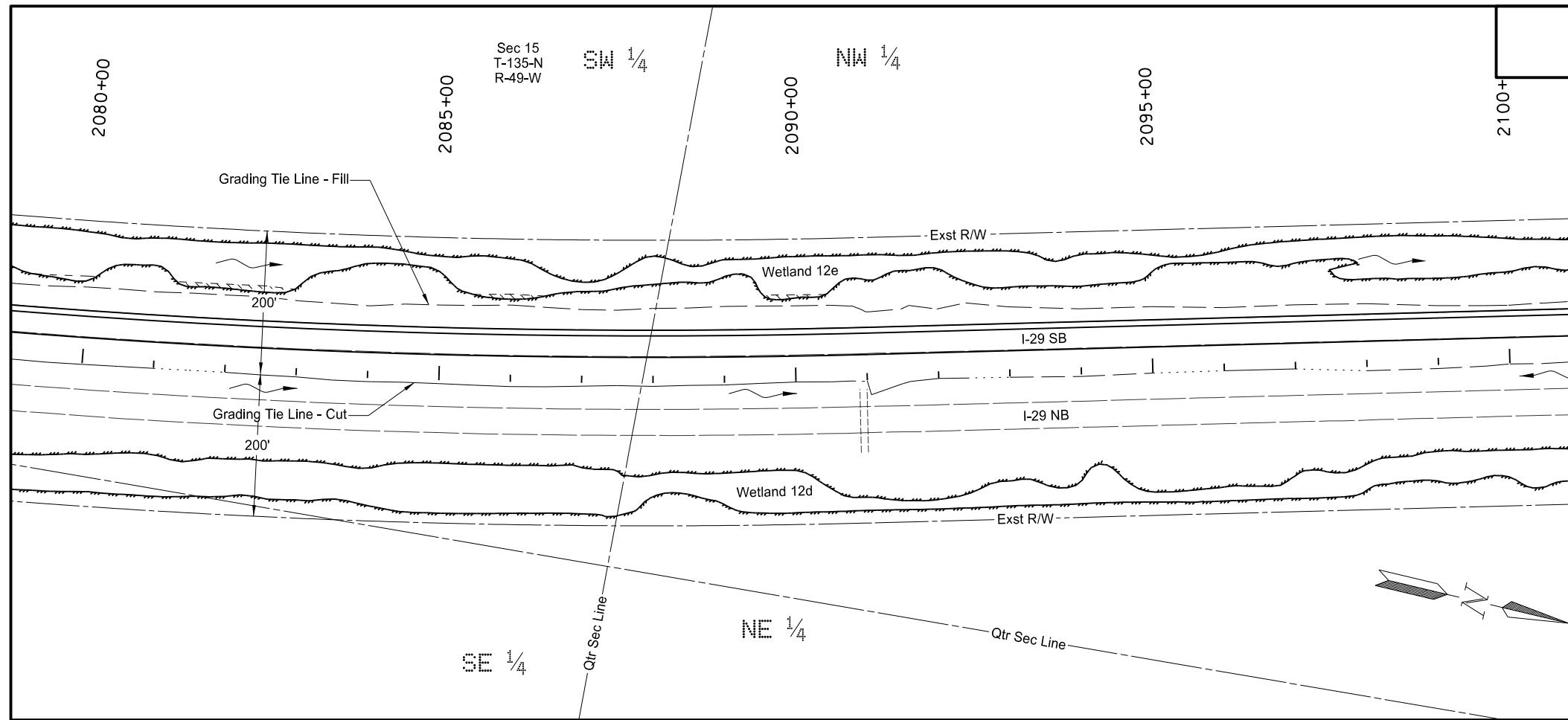

- Other Water Impact Permanent
- Other Water Impact Temporary
- Wetland Impact Permanent
- Wetland Impact Temporary
- Existing Delineated Wetland
- Existing Other Waters

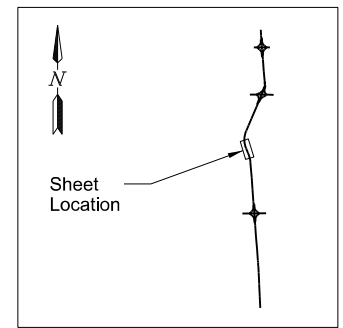



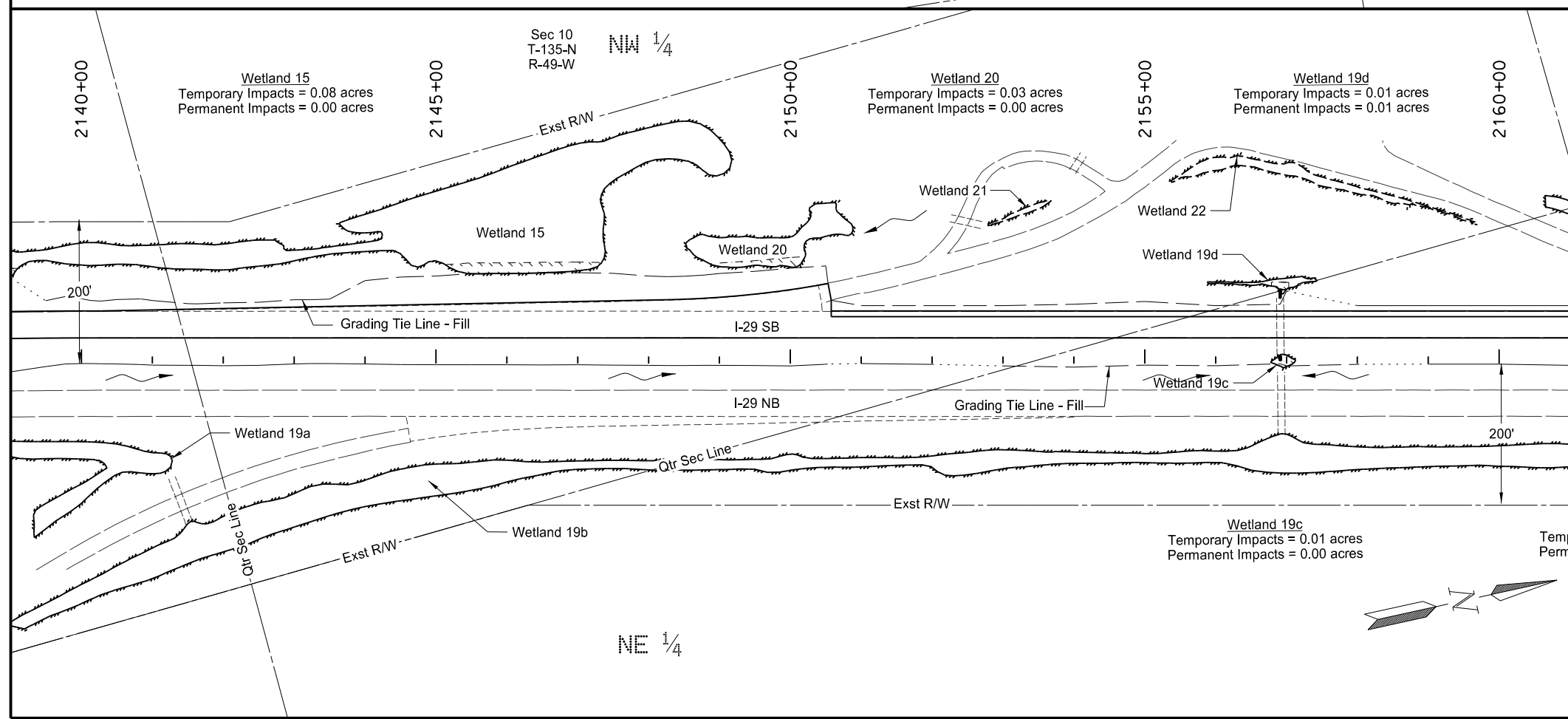
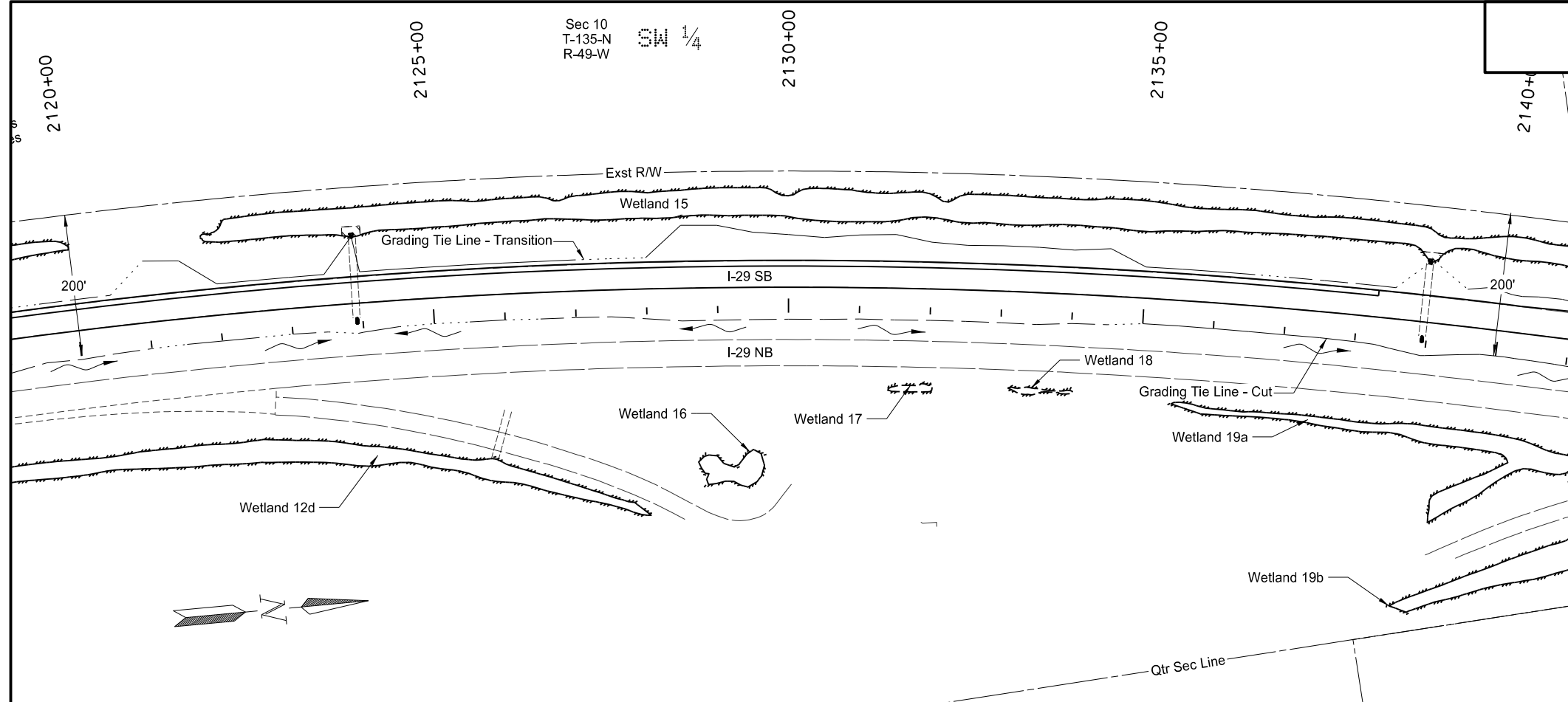

This document was originally issued and sealed by
 Matt Lange,
 Registration Number
 PE- 6870,
 on 08/07/17 and the original document is stored at the
 North Dakota Department
 of Transportation

I-29 - N of Galchutt Exit to Christine Exit
 Wetlands, Mitigation and Environmental
 Interstate 29
 Sta 2080+00 to 2120+00 (SCL29)

STATE	PROJECT NO.	SECTION NO.	SHEET NO.
ND	IM-8-029(170)033	75	15



-  Wetland Impact Permanent
-  Wetland Impact Temporary
-  Existing Delineated Wetland
-  Existing Other Waters

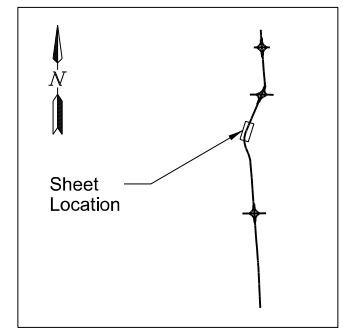



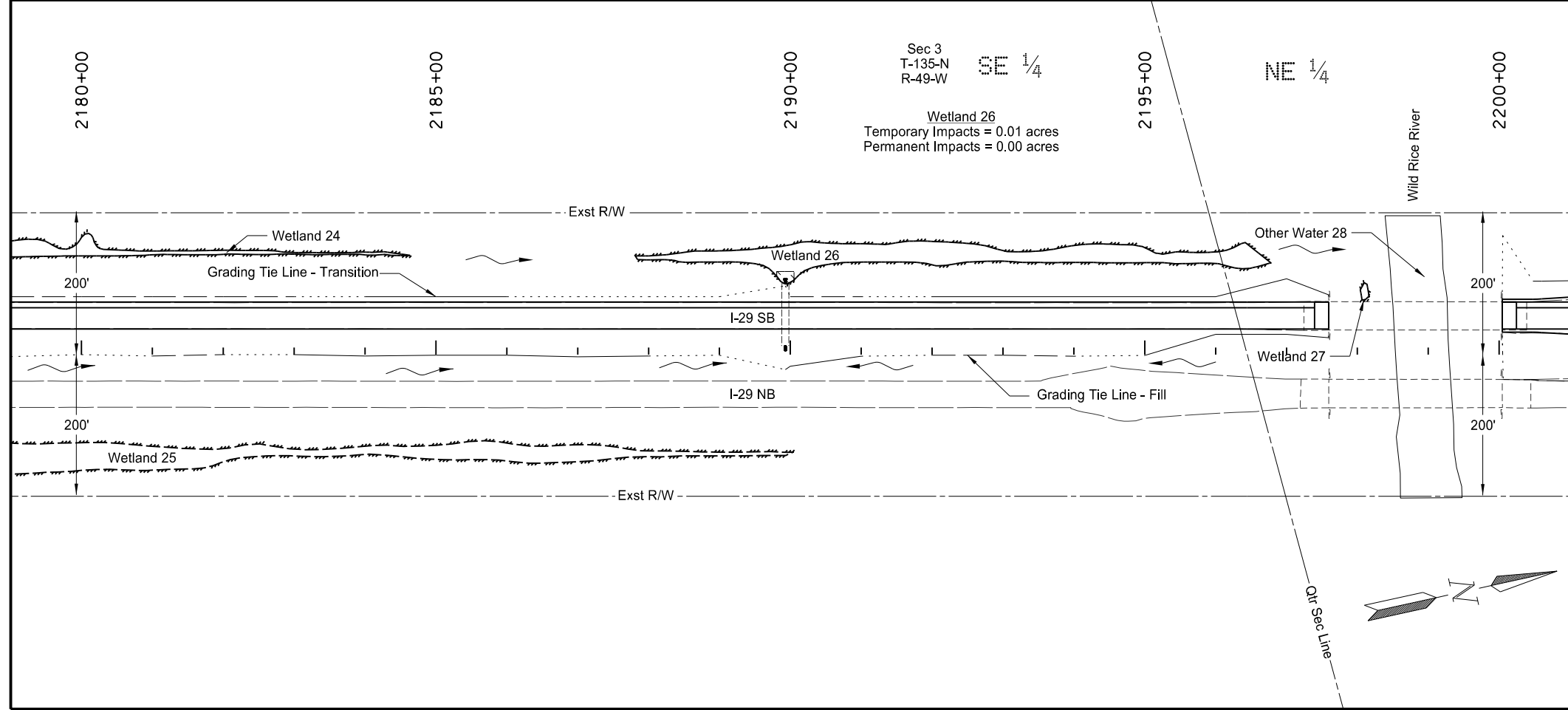
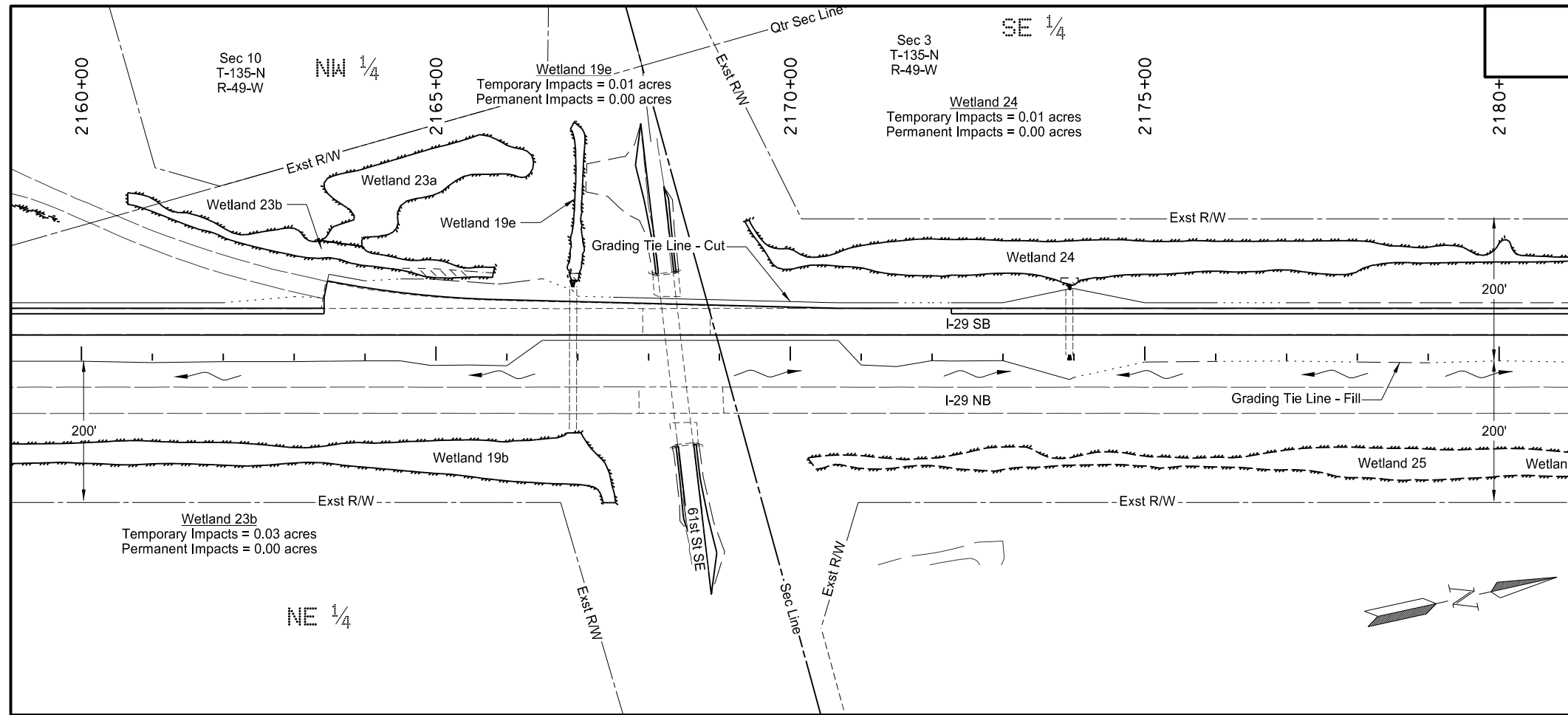

This document was originally issued and sealed by
 Matt Lange,
 Registration Number
 PE- 6870,
 on 08/07/17 and the original document is stored at the
 North Dakota Department
 of Transportation

I-29 - N of Galchutt Exit to Christine Exit
 Wetlands, Mitigation and Environmental
 Interstate 29
 Sta 2120+00 to 2160+00 (SCL29)

STATE	PROJECT NO.	SECTION NO.	SHEET NO.
ND	IM-8-029(170)033	75	16



-  Wetland Impact Permanent
-  Wetland Impact Temporary
-  Existing Delineated Wetland
-  Existing Other Waters

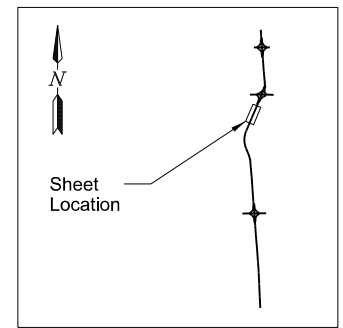



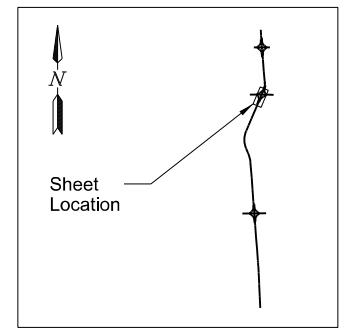
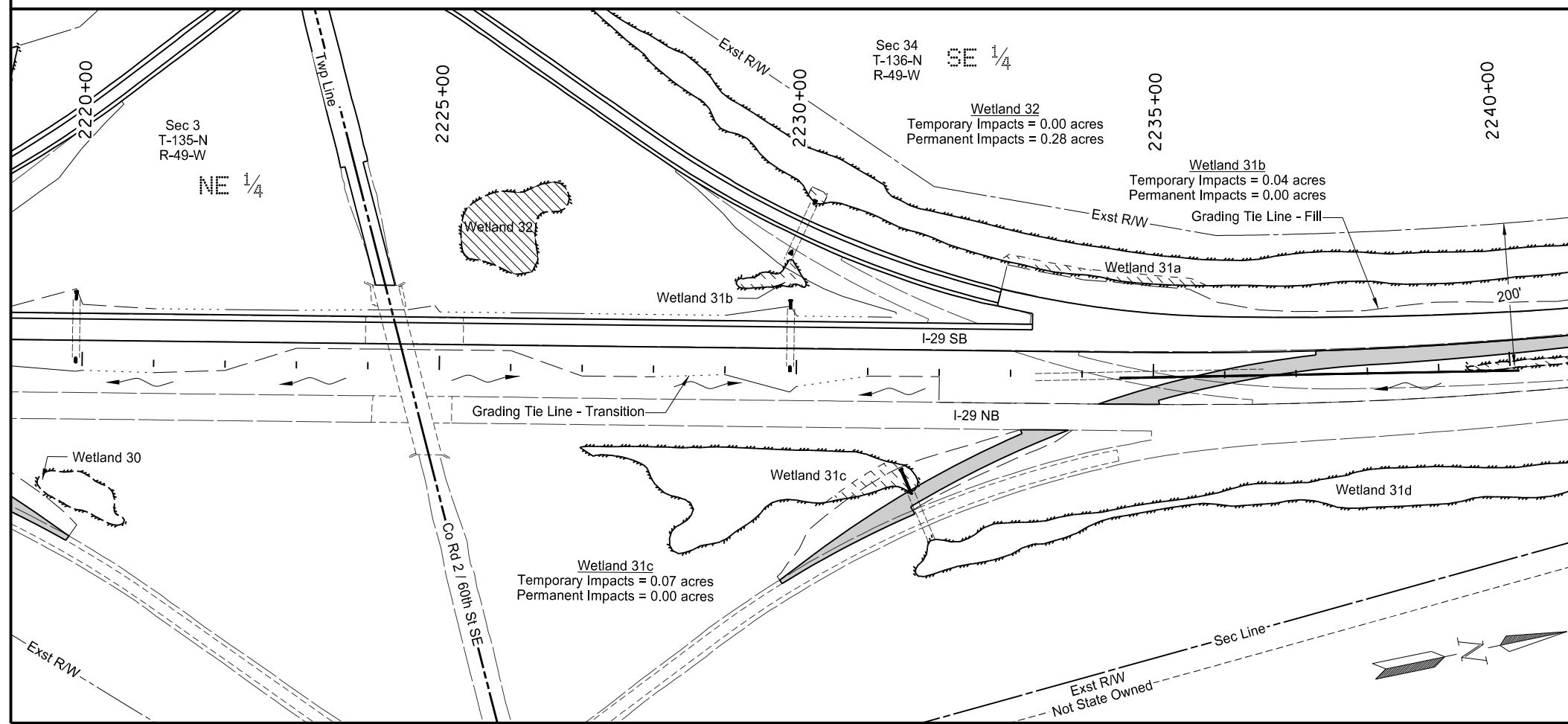
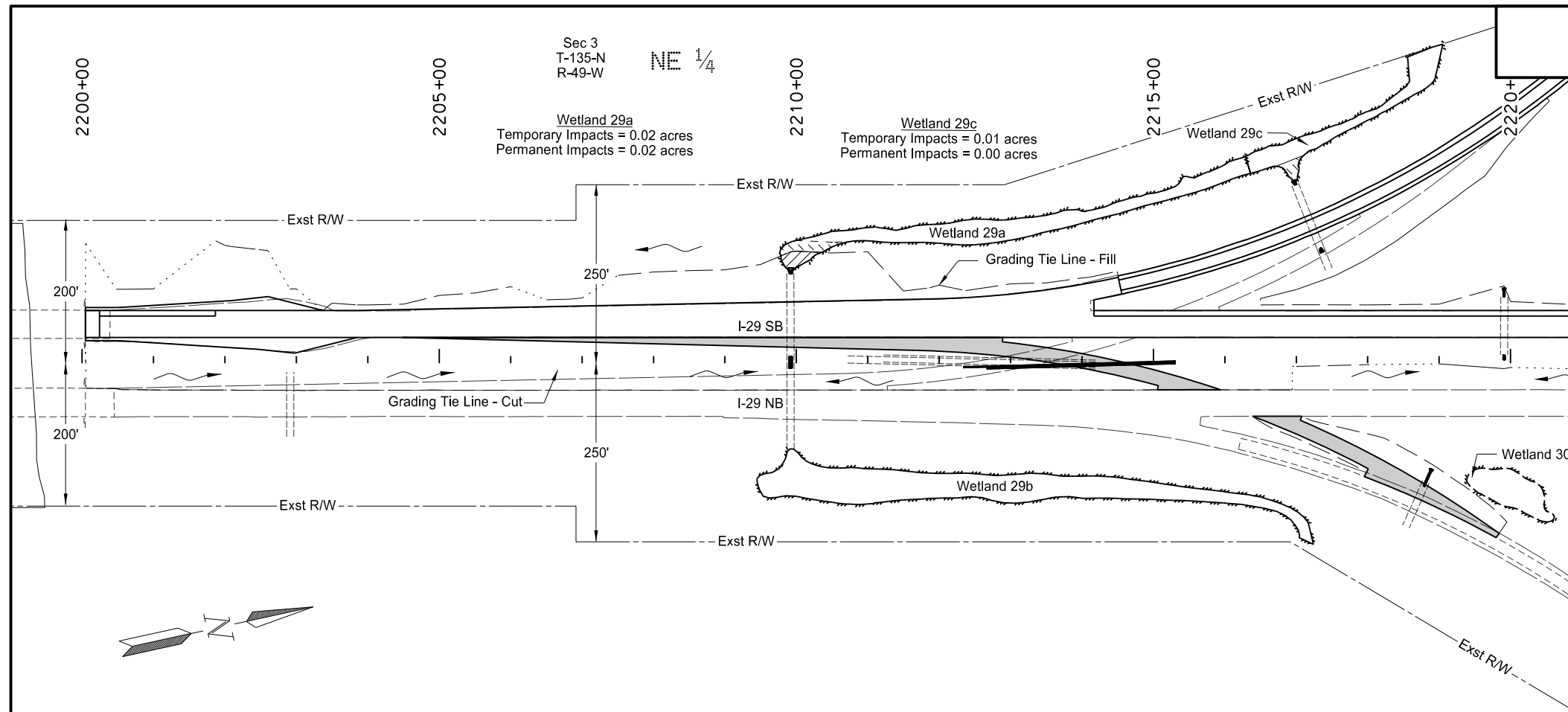

This document was originally issued and sealed by Matt Lange, Registration Number PE- 6870, on 08/07/17 and the original document is stored at the North Dakota Department of Transportation

I-29 - N of Galchutt Exit to Christine Exit
 Wetlands, Mitigation and Environmental
 Interstate 29
 Sta 2160+00 to 2200+00 (SCL29)

STATE	PROJECT NO.	SECTION NO.	SHEET NO.
ND	IM-8-029(170)033	75	17







-  Wetland Impact Permanent
-  Wetland Impact Temporary
-  Existing Delineated Wetland
-  Existing Other Waters

This document was originally issued and sealed by
 Matt Lange,
 Registration Number
 PE- 6870,
 on 08/07/17 and the original document is stored at the
 North Dakota Department
 of Transportation

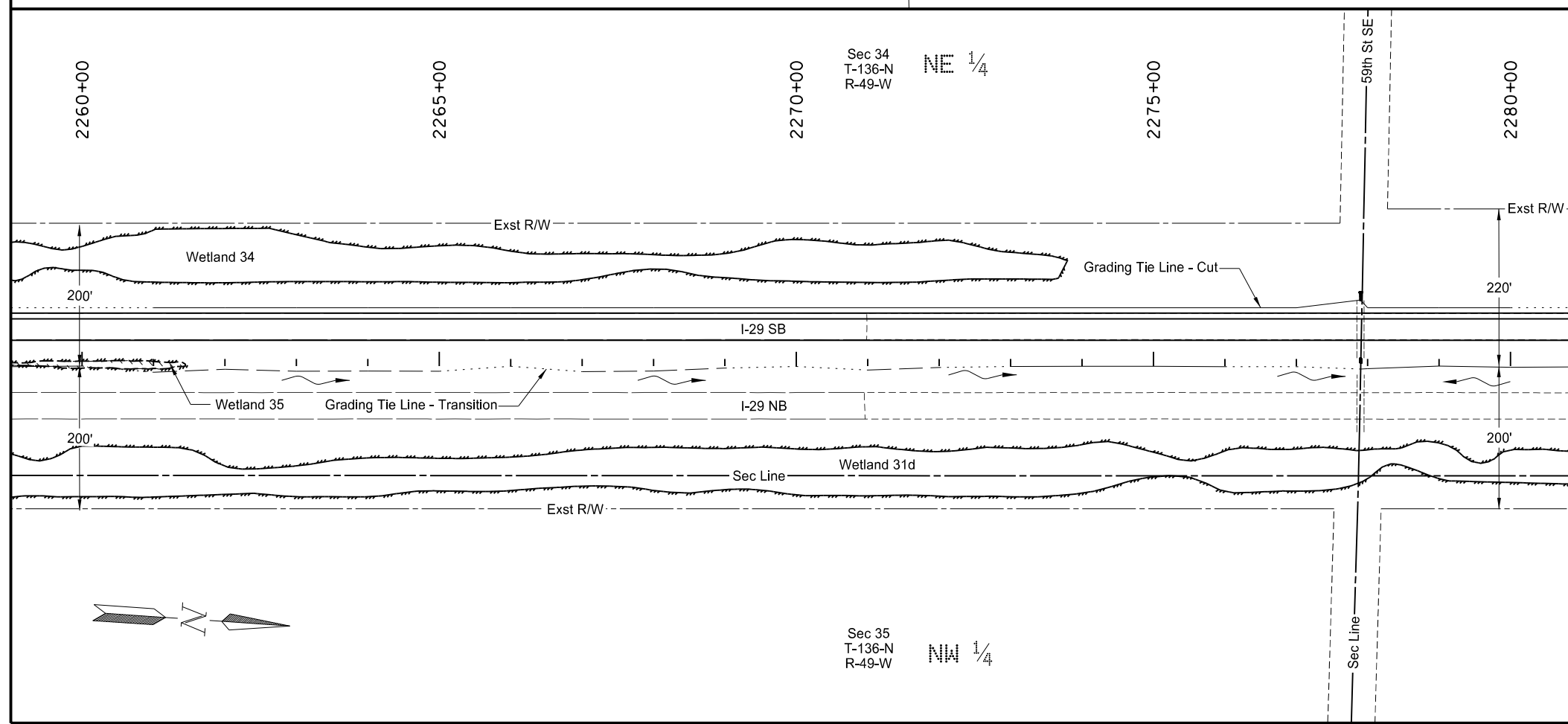
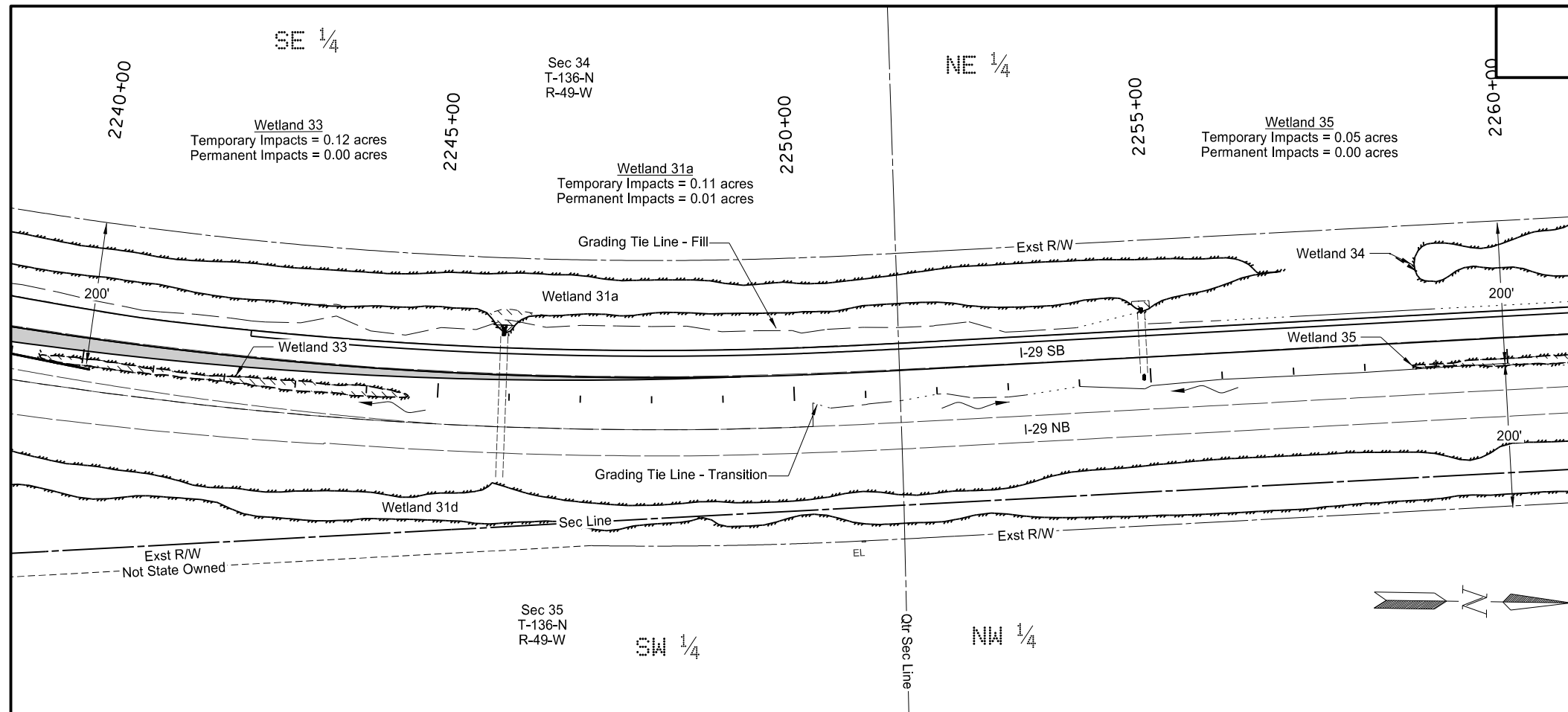
I-29 - N of Galchutt Exit to Christine Exit
 Wetlands, Mitigation and Environmental
 Interstate 29
 Sta 2200+00 to 2240+00 (SCL29)

STATE	PROJECT NO.	SECTION NO.	SHEET NO.
ND	IM-8-029(170)033	75	18



-  Wetland Impact Permanent
-  Wetland Impact Temporary
-  Existing Delineated Wetland
-  Existing Other Waters

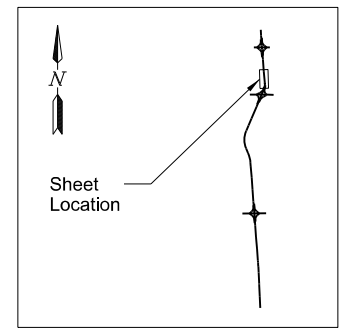



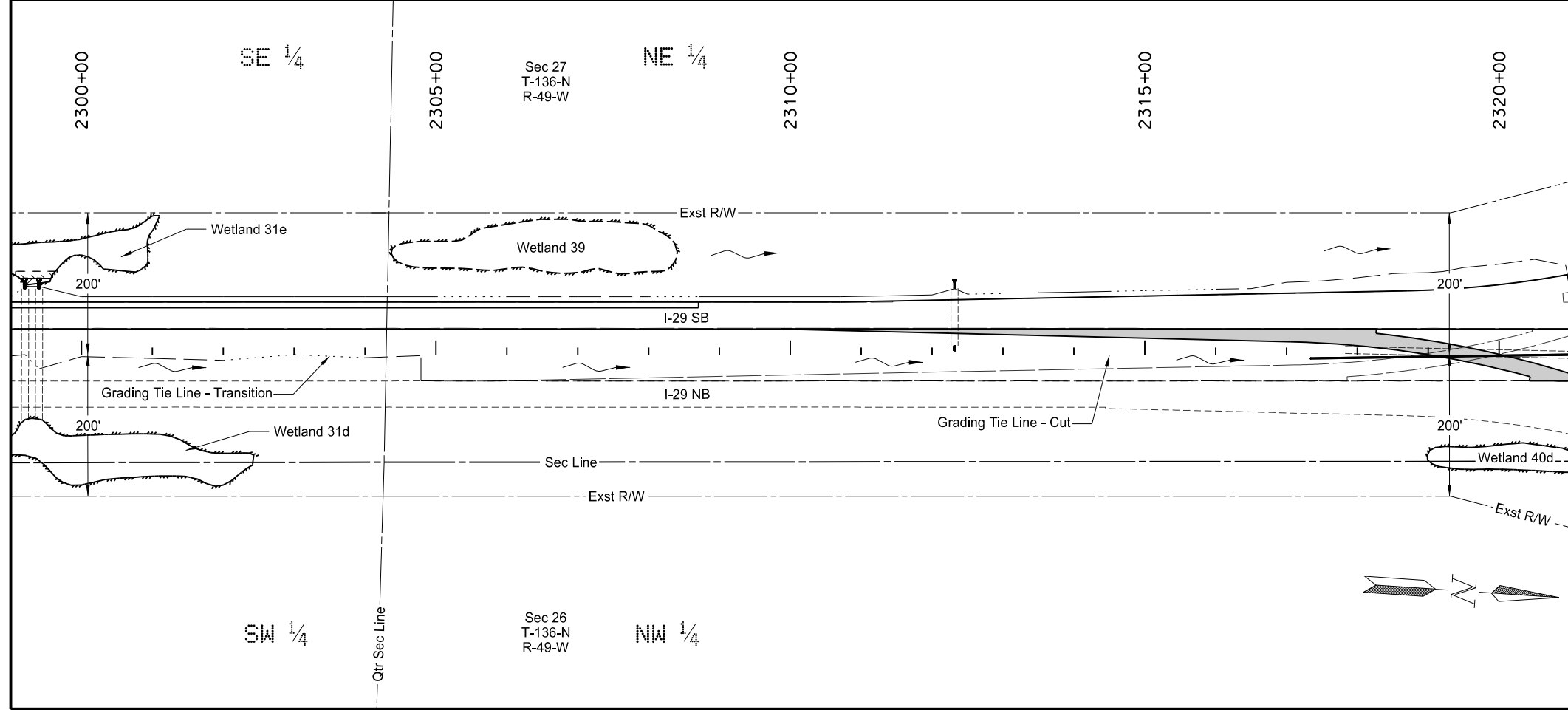
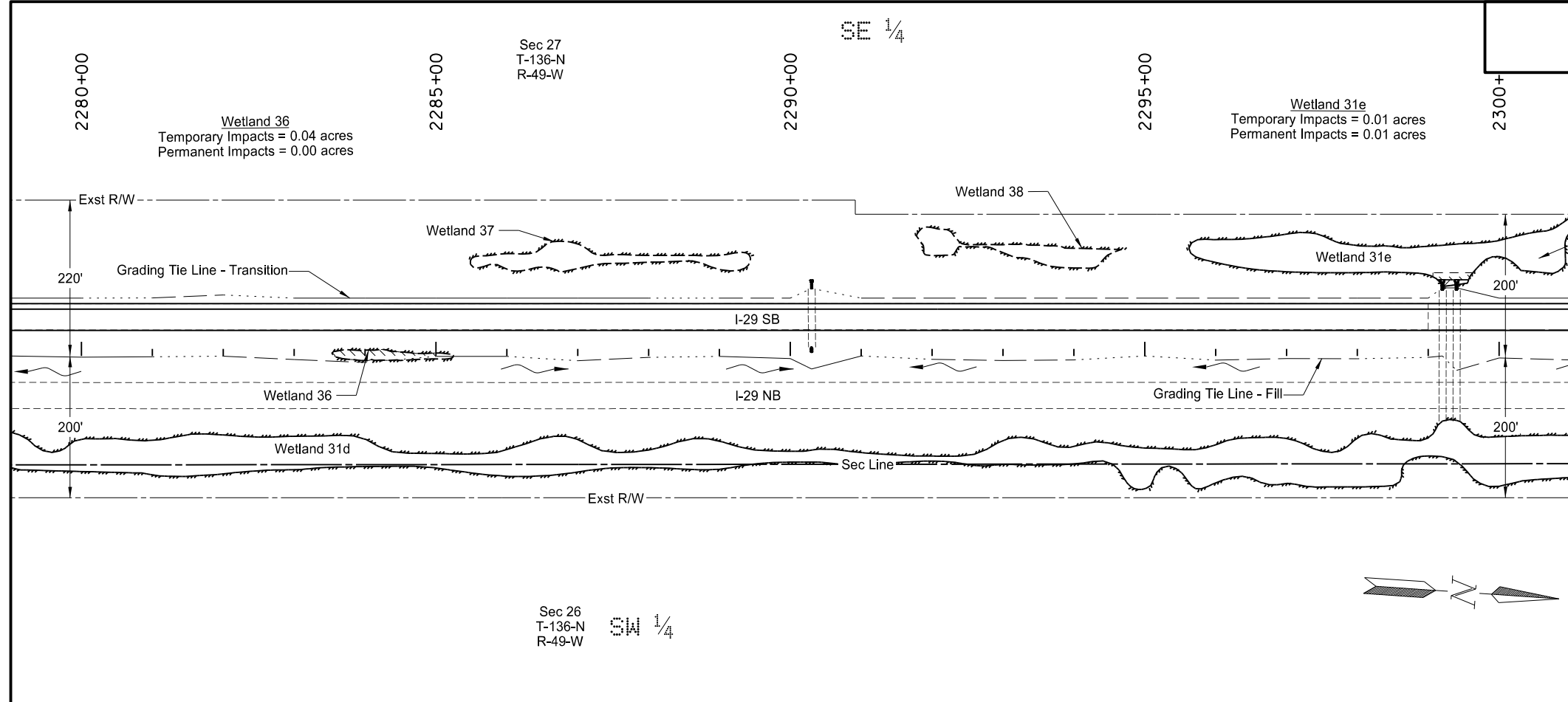

This document was originally issued and sealed by Matt Lange, Registration Number PE- 6870, on 08/07/17 and the original document is stored at the North Dakota Department of Transportation

I-29 - N of Galchutt Exit to Christine Exit
 Wetlands, Mitigation and Environmental
 Interstate 29
 Sta 2240+00 to 2280+00 (SCL29)

STATE	PROJECT NO.	SECTION NO.	SHEET NO.
ND	IM-8-029(170)033	75	19



-  Wetland Impact Permanent
-  Wetland Impact Temporary
-  Existing Delineated Wetland
-  Existing Other Waters

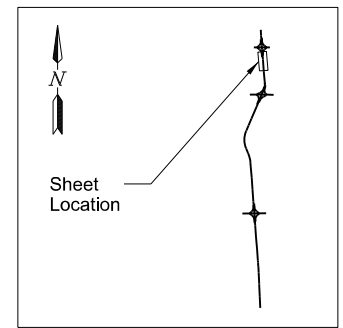

This document was originally issued and sealed by Matt Lange, Registration Number PE- 6870, on 08/07/17 and the original document is stored at the North Dakota Department of Transportation

I-29 - N of Galchutt Exit to Christine Exit
 Wetlands, Mitigation and Environmental
 Interstate 29
 Sta 2280+00 to 2320+00 (SCL29)

STATE	PROJECT NO.	SECTION NO.	SHEET NO.
ND	IM-8-029(170)033	75	20

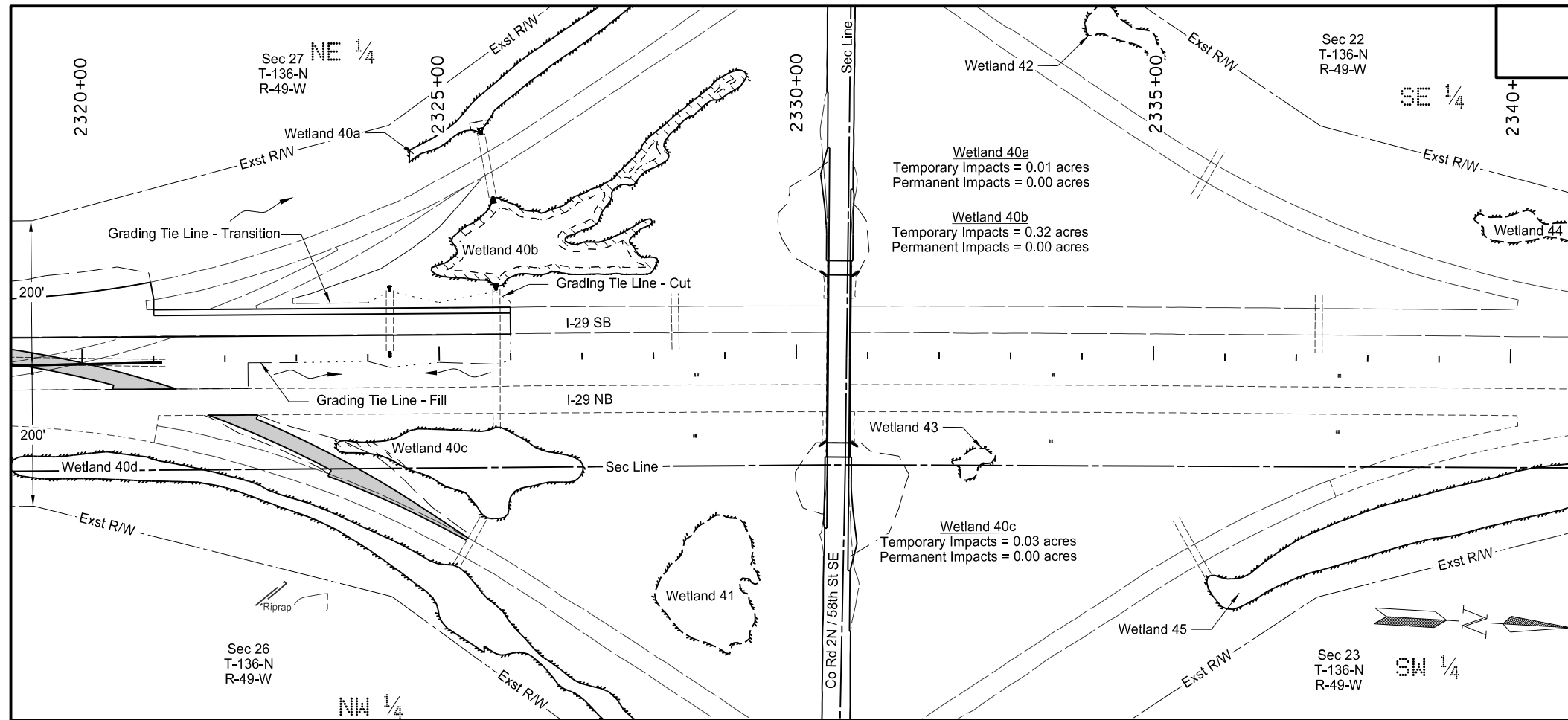



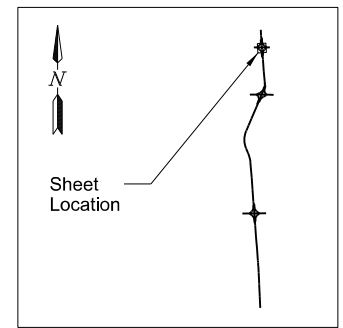

Wetland 40a
Temporary Impacts = 0.01 acres
Permanent Impacts = 0.00 acres

Wetland 40b
Temporary Impacts = 0.32 acres
Permanent Impacts = 0.00 acres

Wetland 40c
Temporary Impacts = 0.03 acres
Permanent Impacts = 0.00 acres



-  Wetland Impact Permanent
-  Wetland Impact Temporary
-  Existing Delineated Wetland
-  Existing Other Waters

This document was originally issued and sealed by
 Matt Lange,
 Registration Number
 PE- 6870,
 on 08/07/17 and the original document is stored at the
 North Dakota Department
 of Transportation

I-29 - N of Galchutt Exit to Christine Exit
 Wetlands, Mitigation and Environmental
 Interstate 29
 Sta 2320+00 to 2340+00 (SCL29)